



# Configuring Local SPAN and ERSPAN

This chapter contains the following sections:

- [Information About SPAN and ERSPAN, on page 1](#)
- [Guidelines and Limitations for SPAN, on page 5](#)
- [Default Settings for SPAN, on page 6](#)
- [Configuring SPAN, on page 6](#)
- [Verifying the SPAN Configuration, on page 20](#)
- [Configuration Example for an ERSPAN Session, on page 20](#)

## Information About SPAN and ERSPAN

The Switched Port Analyzer (SPAN) feature (sometimes called port mirroring or port monitoring) allows network traffic to be analyzed by a network analyzer such as a Cisco SwitchProbe or other Remote Monitoring (RMON) probes.

SPAN allows you to monitor traffic on one or more ports, or one or more VLANs, and send the monitored traffic to one or more destination ports where the network analyzer is attached.

## SPAN Sources

The interfaces from which traffic can be monitored are called SPAN sources. These sources include Ethernet, virtual Ethernet, port-channel, port profile, and VLAN. When a VLAN is specified as a SPAN source, all supported interfaces in the VLAN are SPAN sources. When a port profile is specified as a SPAN source, all ports that inherit the port profile are SPAN sources. Traffic can be monitored in the receive direction, the transmit direction, or both directions for Ethernet and virtual Ethernet source interfaces as described by the following:

- **Receive source (Rx)**—Traffic that enters the switch through this source port is copied to the SPAN destination port.
- **Transmit source (Tx)**—Traffic that exits the switch through this source port is copied to the SPAN destination port

## Characteristics of SPAN Sources

A local SPAN source has these characteristics:

- Can be port type Ethernet, virtual Ethernet, port profile, or VLAN.
- Cannot be a destination port or port profile
- Can be configured to monitor the direction of traffic — receive, transmit, or both.
- Can be in the same or different VLANs.
- For VLAN SPAN sources, all active ports in the source VLAN are included as source ports.
- Must be on the same host Virtual Service Engine (VSE) as the destination port.
- For port profile sources, all active interfaces attached to the port profile are included as source ports.

## SPAN Destinations

SPAN destinations refer to the interfaces that monitor source ports.

### Characteristics of Local SPAN Destinations

Each local SPAN session must have at least one destination port (also called a monitoring port) that receives a copy of traffic from the source ports or VLANs. A destination port has these characteristics:

- Can be any physical, virtual Ethernet port, or a port profile.
- Cannot be a source port or port profile.
- Is excluded from the source list and is not monitored if it belongs to a source VLAN of any SPAN session or a source port profile.
- Receives copies of transmitted and received traffic for all monitored source ports in the same VSE. If a destination port is oversubscribed, it can become congested. This congestion can affect traffic forwarding on one or more of the source ports.
- Must not be private VLAN mode.
- Can only monitor sources on the same host (VSE)
- In access mode, can receive monitored traffic on all the VLANs.
- In trunk mode, can receive monitored traffic only on the allowed VLANs in the trunk configuration.

### Characteristics of ERSPAN Destinations

- An ERSPAN destination is specified by an IP address.
- In ERSPAN, the source SPAN interface and destination SPAN interface may be on different devices interconnected by an IP network. ERSPAN traffic is Generic Routing Encapsulation (GRE-encapsulated).

## Local SPAN

In Local SPAN, the source interface and destination interface are on the same VSE. The network analyzer is attached directly to the SPAN destination port. The SPAN source can be a port, a VLAN interface, or a port profile. The destination can be a port or port profile.

The diagram shows that traffic transmitted by host A is received on the SPAN source interface. Traffic (ACLs, QoS, and so forth) is processed as usual. Traffic is then replicated. The original packet is forwarded on toward host B. The replicated packet is then sent to the destination SPAN interface where the monitor is attached.

Local SPAN can replicate to one or more destination ports. Traffic can be filtered so that only traffic of interest is sent out the destination SPAN interface.

Local SPAN can monitor all traffic received on the source interface including Bridge Protocol Data Unit (BPDU).

**Figure 1: Local SPAN**

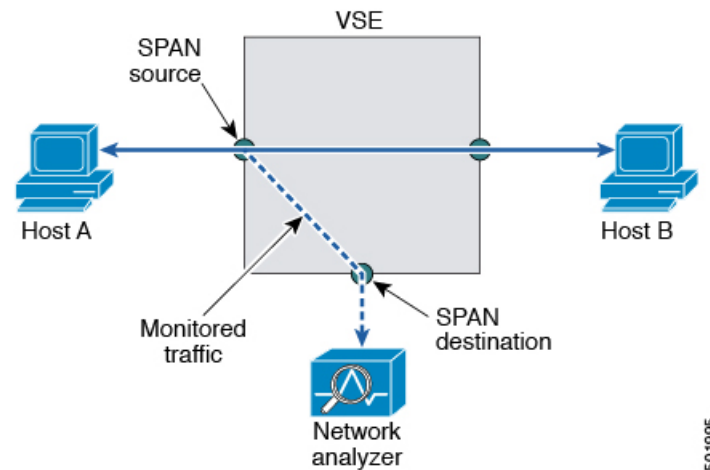

## Encapsulated Remote SPAN

Encapsulated remote SPAN (ERSPAN) monitors traffic in multiple network devices across an IP network and sends that traffic in an encapsulated envelope to destination analyzers. In contrast, Local SPAN cannot forward traffic through the IP network. ERSPAN can be used to monitor traffic remotely. ERSPAN sources can be ports, VLANs, or port profiles.

In the following figure, the ingress and egress traffic for Host A are monitored using ERSPAN. Encapsulated ERSPAN packets are routed from Host A through the routed network to the destination device where they are decapsulated and forwarded to the attached network analyzer. The destination may also be on the same Layer 2 network as the source.

Figure 2: ERSPAN Example

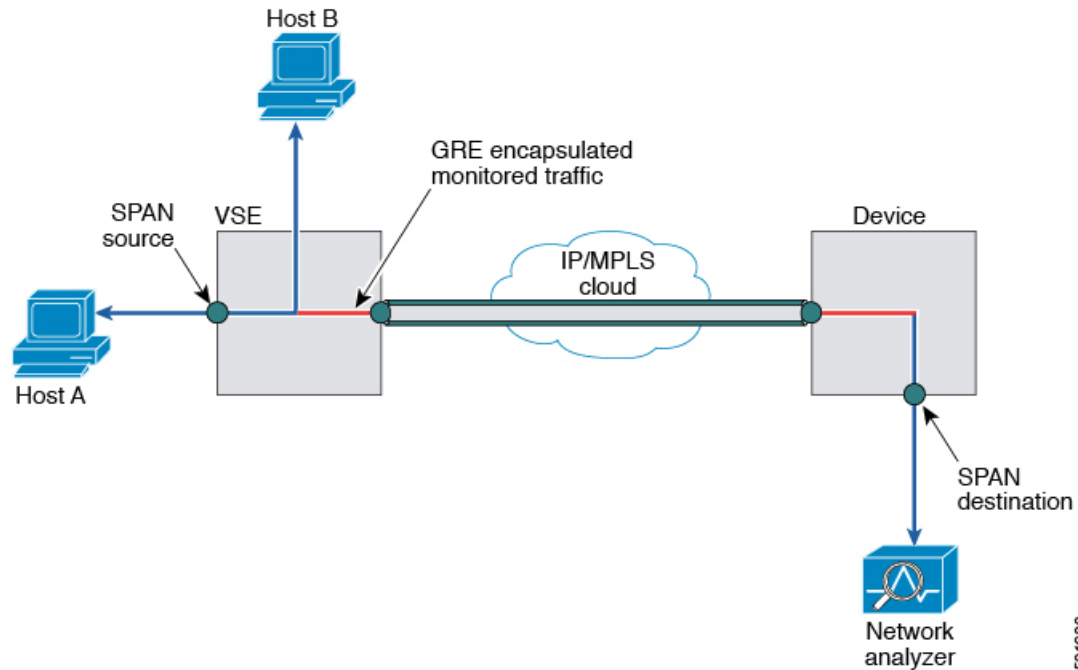

501980

## Network Analysis Module

You can also use the Cisco Network Analysis Module (NAM) to monitor ERSPAN data sources for application performance, traffic analysis, and packet header analysis.

## SPAN Sessions

You can create up to 64 total SPAN sessions (Local SPAN plus ERSPAN) on the VSE.

You must configure an ERSPAN session ID that is added to the ERSPAN header of the encapsulated frame to differentiate between ERSPAN streams of traffic at the termination box. You can also configure the range of flow ID numbers.

When trunk ports are configured as SPAN sources and destinations, you can filter VLANs to send to the destination ports from among those allowed. Both sources and destinations must be configured to allow the VLANs.

The following figure shows one example of a VLAN-based SPAN configuration in which traffic is copied from three VLANs to three specified destination ports. You can choose which VLANs to allow on each destination port to limit the traffic transmitted. In the figure, the device transmits packets from one VLAN at each destination port. The destinations in this example are trunks on which allowed VLANs are configured.



**Note** VLAN-based SPAN sessions cause all source packets to be copied to all destinations, whether the packets are required at the destination or not. VLAN traffic filtering occurs at transmit destination ports.

Figure 3: VLAN-based SPAN Configuration Example

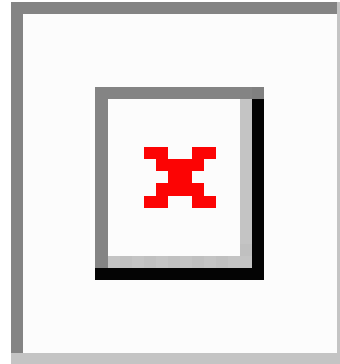

## Guidelines and Limitations for SPAN

- A maximum of 64 SPAN sessions (Local SPAN plus ERSPAN) can be configured on the Virtual Supervisor Module (VSM).
- A maximum of 32 source VLANs are allowed in a session.
- A maximum of 32 destination interfaces are allowed for a Local SPAN session.
- A maximum of 8 destination port-profiles are allowed for a Local SPAN session.
- A maximum of 16 source port-profiles are allowed in a session.
- A maximum of 128 source interfaces are allowed in a session.



### Caution Overload Potential

To avoid an overload on uplink ports, use caution when configuring ERSPAN, especially when sourcing VLANs. The uplink that the VM kernel uses might get overloaded due to ERSPAN traffic. VSM-VSE communication might also be impacted. For example, when the Nexus 1000VE is configured for Layer 3 connectivity, both AIPC traffic and ERSPAN traffic use the same VM kernel NIC.

- A port can be configured in a maximum of four SPAN sessions.
- A port can be a source in a maximum of four SPAN sessions.
- The destination port used in one SPAN session cannot also be used as the destination port for another SPAN session.
- You cannot configure a port as both a source and destination port.
- In a SPAN session, packets that source ports receive may be replicated even though they are not transmitted on the ports. The following are examples of this behavior:
  - Traffic that results from flooding
  - Broadcast and multicast traffic

- For VLAN SPAN sessions switched on the same VLAN with both receive and transmit configured, two packets (one from receive and one from transmit) are forwarded from the destination port.

## Default Settings for SPAN

Parameters	Default
State	SPAN sessions are created in the shut state.
Description	blank
Traffic direction for source interface or port profile	both
Traffic direction for source VLAN	receive (ingress or RX)

## Configuring SPAN

This section describes how to configure SPAN and includes the following procedures:

- Configuring a Local SPAN Session
- Configuring an ERSPAN Port Profile
- Configuring an ERSPAN Session
- Shutting Down a SPAN Session
- Resuming a SPAN Session
- Verifying the SPAN Configuration

### Configuring a Local SPAN Session

This procedure involves creating the SPAN session in monitor configuration mode, and then, optionally, configuring allowed VLANs in interface configuration mode.

It is important to know the following information about SPAN:

- SPAN sessions are created in the shut state by default.
- When you create a SPAN session that already exists, any additional configuration is added to that session. To make sure that the session is cleared of any previous configuration, you can delete the session first. This procedure includes how to do this.
- The source and destination ports are already configured in either access or trunk mode. For more information, see the *Cisco Nexus 1000VE Interface Configuration Guide*.

#### Before you begin

- Log in to the CLI in EXEC mode.

- Know that number of the SPAN session that you are going to configure.

### Procedure

	Command or Action	Purpose
<b>Step 1</b>	switch# <b>configure terminal</b>	Enters global configuration mode.
<b>Step 2</b>	switch(config)# <b>no monitor session</b> <i>session-number</i>	Clears the specified session.
<b>Step 3</b>	switch(config)# <b>monitor session</b> <i>session-number</i>	Creates a session with the given session number and places you in monitor configuration mode to further configure the session.
<b>Step 4</b>	switch(config-monitor)# <b>description</b> <i>description</i>	<p>Adds a description for the specified SPAN session.</p> <p>The <i>description</i> can be up to 32 alphanumeric characters.</p> <p>The default is blank (no description)</p>
<b>Step 5</b>	switch(config-monitor)# <b>source {interface</b> <i>{type} {id}   vlan {id   range}   port-profile</i> <i>{name}}</i> [ <b>rx   tx   both</b> ]	<p>For the specified session, configures the sources and the direction of traffic to monitor.</p> <ul style="list-style-type: none"> <li>• For the <i>type</i> argument, specify the interface type—Ethernet or vEthernet.</li> <li>• For the <i>id</i> argument, specify the vEthernet number, the Ethernet slot/port, or the VLAN ID to monitor.</li> <li>• For the <i>range</i> argument, specify the VLAN range to monitor.</li> <li>• For the <i>name</i> argument, specify the name of the existing port profile. This port profile is different from the port profile created to carry ERSPAN packets through the IP network as defined in the <a href="#">Configuring an ERSPAN Port Profile, on page 9</a>.</li> <li>• For the <b>traffic direction</b> keywords, specify as follows: <ul style="list-style-type: none"> <li>• <b>rx</b> is the VLAN default indicates receive.</li> <li>• <b>tx</b> indicates transmit.</li> <li>• <b>both</b> is the default keyword.</li> </ul> </li> </ul>

	Command or Action	Purpose
<b>Step 6</b>	(Optional) Repeat Step 5 to configure additional SPAN sources.	
<b>Step 7</b>	(Optional) <code>switch(config-monitor)# filter vlan {id   range}</code>	For the specified SPAN session, configures the filter from among the source VLANs.
<b>Step 8</b>	(Optional) Repeat Step 7 to configure all source VLANs to filter.	
<b>Step 9</b>	<code>switch(config-monitor)# destination {interface {type} {id   range}   port-profile {name}}</code>	For the specified SPAN session, configures the destination(s) for copied source packets. <ul style="list-style-type: none"> <li>• For the <i>type</i> argument, specify the interface type—Ethernet or vEthernet.</li> <li>• For the <i>id</i> argument, specify the vEthernet number or the Ethernet slot/port to monitor.</li> <li>• For the <i>name</i> argument specify the name of the port profile to monitor.</li> </ul>
<b>Step 10</b>	(Optional) Repeat Step 9 to configure all SPAN destination ports.	
<b>Step 11</b>	<code>switch(config-monitor)# no shut</code>	Enables the SPAN session. By default, the session is created in the shut state.
<b>Step 12</b>	(Optional) <code>switch(config-monitor)# exit</code>	Exits monitor configuration mode and enters interface configuration mode.
<b>Step 13</b>	(Optional) <code>switch(config-if)# show monitor session session-number</code>	Displays the configured monitor session.
<b>Step 14</b>	<code>switch(config-if)# show interface {type} {id} switchport</code>	Displays the configured port including allowed VLANs. <ul style="list-style-type: none"> <li>• For the <i>type</i> argument, specify the interface type—Ethernet or vEthernet.</li> <li>• For the <i>id</i> argument, specify the vEthernet number or the Ethernet slot/port to monitor.</li> </ul>
<b>Step 15</b>	(Optional) <code>switch(config-if)# copy running-config startup-config</code>	Saves the change persistently through reboots and restarts by copying the running configuration to the startup configuration.

### Example

This example shows how to configure a local SPAN session:



```

switch# configure terminal
switch(config)# no monitor session 3
switch(config)# monitor session 3
switch(config-monitor)# description my_span_session_3
switch(config-monitor)# source interface ethernet 2/1-3, ethernet 3/1 rx
switch(config-monitor)# filter vlan 3-5, 7
switch(config-monitor)# destination interface ethernet 2/5, ethernet 3/7
switch(config-monitor)# no shut
switch(config-monitor)# exit
switch(config-if)# show monitor session 3
switch(config-if)# show interface ethernet 2/5 switchport
switch(config-if)# copy running-config startup-config

```

## Configuring an ERSPAN Port Profile

You can configure a port profile on the VSM to carry ERSPAN packets through the IP network to a remote destination analyzer.

You must complete this configuration for all hosts in vCenter Server.

The ERSPAN configuration requires a Layer 3 capable port profile. To configure this feature in a Layer 2 mode, you must configure the Layer 3 capable port profile as described in this section. However, if you configure this feature in a Layer 3 mode, you must use the existing Layer 3 capable port profile.

This procedure includes steps to configure the port profile for the following requirements:

- ERSPAN for Layer 3 control.
- An access port profile. It cannot be a trunk port profile.

Only one vMKNIC can be assigned to this Layer 3 control port profile per host as follows:

- If more than one vMKNIC is assigned to a host, the first one assigned takes effect. The second one is not considered a Layer 3 control vMKNIC.
- If more than one vMKNIC is assigned to a host, and you remove the second assigned one, the VSE does not use the first assigned one. Instead, you must remove both vMKNICs and then add one back.



---

**Note** Ensure that the IP subnet assigned to a vMKNIC does not interfere with the existing connectivity between the host and the vCenter.

---

### Before you begin

- Log in to the CLI in EXEC mode
- Establish the name to be used for this port profile



---

**Note** The port profile name is used to configure the VM Kernel NIC (vMKNIC). A vMKNIC is required on each ESX host to send ERSPAN-encapsulated IP packets. It must have IP connectivity to the ERSPAN destination IP address.

---

- Establish the name of the VMware port group to which this profile maps.
- Create the system VLAN that sends IP traffic to the ERSPAN destination; and you know the VLAN ID that will be used in this configuration.
- Obtain the VMware documentation for adding a new virtual adapter.



**Note** To ensure that VSM-VSE control communication messages are not dropped, we recommend that you configure the Quality of Service (QoS) queuing feature on the uplink interface to which the vMKNIC with capability Layer 3 capable control is mapped.

### Procedure

	Command or Action	Purpose
<b>Step 1</b>	switch# <b>configure terminal</b>	Enters global configuration mode.
<b>Step 2</b>	switch(config)# <b>port-profile</b> <i>port_profile_name</i>	Creates the port profile and enters global configuration mode for the specified port profile. This command saves the port profile in the running configuration.  The port profile name can be up to 80 characters and must be unique for each port profile on the Cisco Nexus 1000VE.
<b>Step 3</b>	switch(config-prot-prof)# <b>capability l3control</b>	Configures the port profile to carry ERSPAN traffic and saves the port profile in the running configuration.
<b>Step 4</b>	switch(config-prot-prof)# <b>vmware port-group</b> <i>name</i>	Designates the port profile as a VMware port group and adds the name of the VMware port group to which this profile maps. This command saves the settings in the running configuration.  The port profile is mapped to a VMware port group of the same name. When a vCenter Server connection is established, the port group created in the Cisco Nexus 1000VE is then distributed to the virtual switch on the vCenter Server.  The <i>name</i> argument is the same as the port profile name if you do not specify a port group name. If you want to map the port profile to a different port group name, use the name option followed by the alternate name.
<b>Step 5</b>	switch(config-prot-prof)# <b>switchport mode</b> <b>access</b>	Designates the interfaces as switch access ports (the default).

	Command or Action	Purpose
<b>Step 6</b>	switch(config-prot-prof)# <b>switchport access vlan <i>id</i></b>	Assigns a VLAN ID to the access port for this port profile and saves the setting in the running configuration.  This VLAN is used to send IP traffic to the ERSPAN destination.
<b>Step 7</b>	switch(config-prot-prof)# <b>no shutdown</b>	Enables the interface in the running configuration.
<b>Step 8</b>	switch(config-prot-prof)# <b>system vlan <i>id</i></b>	Associates the system VLAN ID with the port profile and saves it in the running configuration.  The ID must match the VLAN ID that is assigned to the access port. If it does not match, the following error message is generated:  ERROR: System vlan being set does not match the switchport access vlan 2
<b>Step 9</b>	switch(config-prot-prof)# <b>state enabled</b>	Enables the port profile in the running configuration.  This port profile is now ready to send out ERSPAN packets on all ESX hosts with ERSPAN sources.
<b>Step 10</b>	(Optional) switch(config-prot-prof)# <b>show port-profile name <i>port_profile_name</i></b>	Displays the configuration for the specified port profile as it exists in the running configuration.
<b>Step 11</b>	(Optional) switch(config-prot-prof)# <b>copy running-config startup-config</b>	Saves the change persistently through reboots and restarts by copying the running configuration to the startup configuration.
<b>Step 12</b>	Using the VMware documentation, go to vSphere Client and configure a vMKNIC on each ESX host for sending ERSPAN-encapsulated packets. Make sure that the vMKNIC points to this port profile as a new virtual adapter. This vMKNIC must have IP connectivity to the ERSPAN destination IP address.	—

### Example

This example show how to configure a port profile on the VSM:

```
switch# configure terminal
switch(config)# port-profile erspan_profile
switch(config-port-prof)# capability l3control
```

```

switch(config-port-prof)# vmware port-group erspan
switch(config-port-prof)# switchport mode access
switch(config-port-prof)# switchport access vlan 2
switch(config-port-prof)# no shutdown
switch(config-port-prof)# system vlan 2
switch(config-port-prof)# state enabled
switch(config-port-prof)# show port-profile name erspan
port-profile erspan
  description:
  status: enabled
  capability uplink: no
  capability l3control: yes
  system vlans: 2
  port-group: access
  max-ports: 32
  inherit:
  config attributes:
    switchport access vlan 2
    no shutdown
  evaluated config attributes:
    switchport access vlan 2
    no shutdown
  assigned interfaces:
n1000v(config-port-prof)# copy running-config startup-config

```

## Configuring an ERSPAN Session

This procedure involves creating the SPAN session in ERSPAN source configuration mode (config-erspan-source).

SPAN sessions are created in the shut state by default.

When you create a SPAN session that already exists, any additional configuration is added to that session. To make sure the session is cleared of any previous configuration, you can delete the session first.

### Before you begin

- Log in to the CLI in EXEC mode
- Obtain the number of the SPAN session that you are going to configure
- Configure an ERSPAN-capable port profile on the VSM
- Using the VMware documentation for adding a new virtual adapter, configure the required vMKNIC on each ESX host. The vMKNIC must have IP connectivity to the ERSPAN destination IP address for sending ERSPAN-encapsulated packets.
- ERSPAN traffic uses GRE encapsulation. If there are firewalls between the ERSPAN source and destinations, we recommend that you set a rule to allow GRE traffic. This traffic could be identified by IP protocol number 47.

### Procedure

	Command or Action	Purpose
<b>Step 1</b>	switch# <b>configure terminal</b>	Enters global configuration mode.

	Command or Action	Purpose
<b>Step 2</b>	switch(config)# <b>no monitor session</b> <i>session-number</i>	Clears the specified session.
<b>Step 3</b>	switch(config)# <b>monitor session</b> <i>session-number</i> <b>type erspan-source</b>	Creates a session with the given session number and places you in ERSPAN source configuration mode. This configuration is saved in the running configuration.
<b>Step 4</b>	switch(config-erspan-src)# <b>description</b> <i>description</i>	For the specified ERSPAN session, adds a description and saves it in the running configuration.  The <i>description</i> can be up to 32 alphanumeric characters  The default is blank (no description)
<b>Step 5</b>	switch(config-erspan-src)# <b>source</b> { <b>interface</b> <i>type</i> { <i>number</i>   <i>range</i> }   <b>vlan</b> { <i>number</i>   <i>range</i> }   <b>port-profile</b> { <i>name</i> }} [ <b>rx</b>   <b>tx</b>   <b>both</b> ]	For the specified session, configures the sources and the direction of traffic to monitor and saves them in the running configuration.  <ul style="list-style-type: none"> <li>• For the <i>type</i> argument, specify the interface type—ethernet, port-channel, vethernet.</li> <li>• For the <i>number</i> argument, specify the interface slot/port or range, or the VLAN number or range to monitor.</li> <li>• For the <i>name</i> argument, specify the name of the existing port profile.</li> <li>• For the traffic direction keywords, specify as follows: <ul style="list-style-type: none"> <li>• <b>rx</b>— is the VLAN default that indicates receive.</li> <li>• <b>tx</b>— indicates transmit.</li> <li>• <b>both</b>—is the default keyword.</li> </ul> </li> </ul>
<b>Step 6</b>	(Optional) Repeat Step 5 to configure additional ERSPAN sources.	
<b>Step 7</b>	(Optional) switch(config-erspan-src)# <b>filter</b> <b>vlan</b> { <i>number</i>   <i>range</i> }	For the specified ERSPAN session, configures the VLANs, VLAN lists, or VLAN ranges to be monitored; and saves the VLAN arguments to the running configuration.  On the monitor port, only the traffic from the VLANs that match the VLAN filter list are replicated to the destination.

	Command or Action	Purpose
<b>Step 8</b>	(Optional) Repeat Step 7 to configure all source VLANs to filter.	
<b>Step 9</b>	switch(config-erspan-src)# <b>destination ip</b> <i>ip_address</i>	Configures the IP address of the host to which the encapsulated traffic is sent in this monitor session and saves it in the running configuration.
<b>Step 10</b>	(Optional) switch(config-erspan-src)# <b>ip ttl</b> <i>ttl_value</i>	Specifies the IP time-to-live value, from 1 to 255, for ERSPAN packets in this monitor session and saves it in the running configuration.
<b>Step 11</b>	(Optional) switch(config-erspan-src)# <b>ip prec</b> <i>precedence_value</i>	Specifies the IP precedence value, from 0 to 7, for the ERSPAN packets in this monitor session and saves it in the running configuration.  The default value is 0.
<b>Step 12</b>	(Optional) switch(config-erspan-src)# <b>ip dscp</b> <i>dscp_value</i>	Specifies the IP DSCP value, from 0 to 63, for the ERSPAN packets in this monitor session and saves it in the running configuration.  The default is 0.
<b>Step 13</b>	(Optional) switch(config-erspan-src)# <b>mtu</b> <i>mtu_value</i>	Specifies an MTU size (from 50 to 9000) for ERSPAN packets in this monitor session and saves it in the running configuration. The 1500 MTU size limit includes a 50 byte overhead added to monitored packets by ERSPAN. Packets larger than this size are truncated.  The default is 1500.  <b>Note</b> If the ERSPAN destination is a Cisco 6500 Series switch, truncated ERSPAN packets are dropped unless the <b>no mls verify ip length consistent</b> command is configured on the Switch.
<b>Step 14</b>	switch(config-erspan-src)# <b>header-type</b> <i>value</i>	Specifies the ERSPAN header type (2 or 3) used for ERSPAN encapsulation for this monitor session as follows: <ul style="list-style-type: none"> <li>• 2 is the ERSPANv2 header type (the default)</li> <li>• 3 is the ERSPANv3 header type (used with NAM setups. Any other type of destination works only with the default v2 headers.)</li> </ul>

	Command or Action	Purpose
<b>Step 15</b>	switch(config-erspan-src)# <b>erspan-id</b> <i>flow_id</i>	Adds an ERSPAN ID from 1 to 1023) to the session configuration and saves it in the running configuration.  The session ERSPAN ID is added to the ERSPAN header of the encapsulated frame and can be used at the termination box to differentiate between various ERSPAN streams of traffic.
<b>Step 16</b>	switch(config-erspan-src)# <b>no shut</b>	Enables the ERSPAN session and saves it in the running configuration.  By default, the session is created in the shut state.
<b>Step 17</b>	(Optional) switch(config-erspan-src)# <b>show monitor session</b> <i>session_id</i>	Displays the ERSPAN session configuration as it exists in the running configuration.
<b>Step 18</b>	(Optional) switch(config-erspan-src)# <b>copy running-config startup-config</b>	Saves the running configuration persistently through reboots and restarts by copying it to the startup configuration.

### Example

This example shows how to configure a SPAN session:

```
switch# configure terminal
switch(config)# no monitor session 3
switch(config)# monitor session 3 type erspan
switch(config-erspan-src)# description my_erspan_session_3
switch(config-erspan-src)# source interface ethernet 2/1-3, ethernet 3/1 rx
switch(config-erspan-src)# filter vlan 3-5, 7
switch(config-erspan-src)# destination ip 10.54.54.1
switch(config-erspan-src)# ip ttl 64
switch(config-erspan-src)# ip prec 1
switch(config-erspan-src)# ip dscp 24
switch(config-erspan-src)# mtu 1000
switch(config-erspan-src)# header-type 2
switch(config-erspan-src)# erspan-id 51
switch(config-erspan-src)# no shut
switch(config-erspan-src)# show monitor session 3
switch(config-erspan-src)# copy running-config startup-config
```

## Shutting Down a SPAN Session from Global Configuration Mode

### Before you begin

- Log in to the CLI in EXEC mode.
- Determine which session you want to shut down.

**Procedure**

	<b>Command or Action</b>	<b>Purpose</b>
<b>Step 1</b>	switch# <b>configure terminal</b>	Enters global configuration mode.
<b>Step 2</b>	switch(config)# <b>monitor session</b> { <i>session-number</i>   <i>session-range</i>   <b>all</b> } <b>shut</b>	Shuts down the specified SPAN monitor session(s) from global configuration mode. <ul style="list-style-type: none"> <li>• The <i>session-number</i> argument specifies a particular SPAN session number.</li> <li>• The <i>session-range</i> argument specifies a range of SPAN sessions from 1 to 64.</li> <li>• The <b>all</b> keyword specifies all SPAN monitor sessions.</li> </ul>
<b>Step 3</b>	(Optional) switch(config)# <b>show monitor</b>	Displays the status of the SPAN sessions.
<b>Step 4</b>	(Optional) switch(config)# <b>copy running-config startup-config</b>	Saves the running configuration persistently through reboots and restarts by copying it to the startup configuration.

**Example**

This example shows how to shut down a SPAN session:

```
switch# configure terminal
switch(config)# monitor session 3 shut
switch(config)# show monitor
switch(config)# copy running-config startup-config
```

## Shutting Down a SPAN Session from Monitor Configuration Mode

**Before you begin**

- Log in to the CLI in EXEC mode.
- Determine which session you want to shut down.

**Procedure**

	<b>Command or Action</b>	<b>Purpose</b>
<b>Step 1</b>	switch# <b>configure terminal</b>	Enters global configuration mode.
<b>Step 2</b>	switch(config)# <b>monitor session</b> { <i>session-number</i>   <i>session-range</i>   <b>all</b> } [ <b>type</b> <b>erspan-source</b> ]	Specifies the SPAN monitor session(s) you want to shut down from monitor-configuration mode. <ul style="list-style-type: none"> <li>• The <i>session-number</i> argument specifies a particular SPAN session number.</li> </ul>



	Command or Action	Purpose
		<ul style="list-style-type: none"> <li>The <i>session-range</i> argument specifies a range of SPAN sessions from 1 to 64.</li> <li>The <b>all</b> keyword specifies all SPAN monitor sessions.</li> </ul>
<b>Step 3</b>	switch(config)# <b>shut</b>	Shuts down the specified SPAN monitor session(s) from monitor configuration mode.
<b>Step 4</b>	(Optional) switch(config-monitor)# <b>show monitor</b>	Displays the status of the SPAN sessions.
<b>Step 5</b>	(Optional) switch(config-monitor)# <b>copy running-config startup-config</b>	Saves the running configuration persistently through reboots and restarts by copying it to the startup configuration.

### Example

This example shows how to shut down a SPAN session:

```
switch# configure terminal
switch(config)# monitor session 3
switch(config-monitor)# shut
switch(config-monitor)# show monitor
switch(config-monitor)# copy running-config startup-config
```

## Resuming a SPAN Session from Global Configuration Mode

You can discontinue copying packets from one source and destination and then resume from another source and destination in global configuration mode.

### Before you begin

- Log in to the CLI in EXEC mode.
- Determine which SPAN session that you want to configure.

### Procedure

	Command or Action	Purpose
<b>Step 1</b>	switch# <b>configure terminal</b>	Enters global configuration mode.
<b>Step 2</b>	switch(config)# [ <b>no</b> ] <b>monitor session</b> { <i>session-number</i>   <i>session-range</i>   <b>all</b> } <b>shut</b>	Shuts down the specified SPAN monitor session(s) from global configuration mode. <ul style="list-style-type: none"> <li>The <i>session-number</i> argument specifies a particular SPAN session number.</li> <li>The <i>session-range</i> argument specifies a range of SPAN sessions from 1 to 64.</li> </ul>

	Command or Action	Purpose
		<ul style="list-style-type: none"> <li>The <b>all</b> keyword specifies all SPAN monitor sessions.</li> </ul>
<b>Step 3</b>	(Optional) switch(config)# <b>show monitor</b>	Displays the status of the SPAN sessions.
<b>Step 4</b>	(Optional) switch(config)# <b>copy running-config startup-config</b>	Saves the running configuration persistently through reboots and restarts by copying it to the startup configuration.

### Example

This example shows how to resume a SPAN configuration using the global configuration mode:

```
switch# configure terminal
switch(config)# no monitor session 3 shut
switch(config)# show monitor
switch(config)# copy running-config startup-config
```

## Resuming a SPAN Session from Monitor Configuration Mode

You can discontinue copying packets from one source and destination and then resume from another source and destination in monitor configuration mode.

### Before you begin

- Log in to the CLI in EXEC mode.
- Determine which SPAN session that you want to configure.

### Procedure

	Command or Action	Purpose
<b>Step 1</b>	switch# <b>configure terminal</b>	Enters global configuration mode.
<b>Step 2</b>	switch(config)# [ <b>no</b> ] <b>monitor session</b> { <i>session-number</i>   <i>session-range</i>   <b>all</b> } <b>shut</b>	Shuts down the specified SPAN monitor session(s) from monitor configuration mode. <ul style="list-style-type: none"> <li>The <i>session-number</i> argument specifies a particular SPAN session number.</li> <li>The <i>session-range</i> argument specifies a range of SPAN sessions from 1 to 64.</li> <li>The <b>all</b> keyword specifies all SPAN monitor sessions.</li> </ul>
<b>Step 3</b>	(Optional) switch(config-monitor)# <b>show monitor</b>	Displays the status of the SPAN sessions.

	Command or Action	Purpose
<b>Step 4</b>	(Optional) switch(config-monitor)# <b>show monitor session</b> <i>session-id</i>	Displays the detailed configuration and status of a specific SPAN session for verification.
<b>Step 5</b>	(Optional) switch(config-monitor)# <b>copy running-config startup-config</b>	Saves the running configuration persistently through reboots and restarts by copying it to the startup configuration.

### Example

This example shows how to resume a SPAN configuration using the monitor configuration mode:

```
switch# configure terminal
switch(config)# monitor session 3
switch(config-monitor)# no shut
switch(config-monitor)# show monitor
switch(config-monitor)# show monitor session 3
switch(config-monitor)# copy running-config startup-config
```

## Configuring the Allowable ERSPAN Flow IDs

Restrict the allowable range of available flow IDs that can be assigned to ERSPAN sessions

The available ERSPAN flow IDs are from 1 to 1023.

### Before you begin

- Log in to the CLI in EXEC mode.
- Determine the restricted range of ERSPAN flow IDs that you want to designate.

### Procedure

	Command or Action	Purpose
<b>Step 1</b>	switch# <b>configure terminal</b>	Enters global configuration mode.
<b>Step 2</b>	switch(config)# [ <b>no</b> ] <b>limit-resource erspan-flow-id minimum</b> <i>min_val</i> <b>maximum</b> <i>max_val</i>	Restricts the allowable range of ERSPAN flow IDs that can be assigned.  The allowable range is from 1 to 1023.  The defaults are as follows:  The minimum value is 1  The maximum value is 1023  The <b>no</b> form of this command removes any configured values and restores default values.
<b>Step 3</b>	(Optional) switch(config)# <b>show running monitor</b>	Displays changes to the default limit-resource erspan-flow-id values for verification

	Command or Action	Purpose
<b>Step 4</b>	(Optional) switch(config)# <b>copy running-config startup-config</b>	Saves the change persistently through reboots and restarts by copying the running configuration to the startup configuration.

### Example

This example shows how to configure a designated ERSPAN flow ID:

```
switch# configure terminal
switch(config)# limit-resource erspan-flow-id minimum 20 maximum 40
switch(config)# show monitor
switch(config)# show running monitor
switch(config)# copy running-config startup-config
```

## Verifying the SPAN Configuration

Use one of the following commands to verify the configuration:

Command	Purpose
<b>show monitor session</b> {all   <i>session-number</i>   <b>range</b> <i>session-range</i> } [brief]	Displays the SPAN session configuration.
<b>show monitor</b>	Displays Ethernet SPAN information.
<b>module vse</b> <i>module-number</i> <b>execute vemcmd show span</b>	Displays the configured SPAN sessions on a VSE module.
<b>show port-profile</b> <i>name</i> <i>port_profile_name</i>	Displays a port profile.

## Configuration Example for an ERSPAN Session

This example shows how to create an ERSPAN session for a source Ethernet interface and destination IP address on the Cisco Nexus 1000VE. Packets arriving at the destination IP are identified by the ID 999 in their header.

```
switch# monitor session 2 type erspan-source
switch(config-erspan-src)# source interface ethernet eth3/1
switch(config-erspan-src)# source port-profile my_profile_src
switch(config-erspan-src)# destination ip 10.54.54.1
switch(config-erspan-src)# erspan-id 999
switch(config-erspan-src)# mtu 1000
switch(config-erspan-src)# no shut

switch(config-erspan-src)# show monitor session 2
  session 2
  -----
type           : erspan-source
state          : up
source intf    :
```

```

    rx          : Eth3/3
    tx          : Eth3/3
    both       : Eth3/3
source VLANs  :
    rx          :
    tx          :
    both       :
source port-profile :
    rx          : my_profile_src
    tx          : my_profile_src
    both       : my_profile_src
filter VLANs  : filter not specified
destination IP : 10.54.54.1
ERSPAN ID     : 999
ERSPAN TTL    : 64
ERSPAN IP Prec. : 0
ERSPAN DSCP   : 0
ERSPAN MTU    : 1000
ERSPAN Header Type: 2

switch(config-erspan-src)# module vse 3 execute vemcmd show span

VSE SOURCE IP: 10.54.54.10

HW SSN ID   ERSpan ID   HDR VER   DST LTL/IP
    1             local    49,51,52,55,56
    2             999      2    10.54.54.1

```

## Example of Configuring a SPAN Session

This example shows how to create a SPAN session for a source ethernet interface and destination IP address on the Cisco Nexus 1000VE:

```

switch(config)# no monitor session 1
switch(config)# monitor session 1
switch(config-monitor)# source interface ethernet 2/1-3
switch(config-monitor)# source interface eth2/1
switch(config-monitor)# source port-profile my_profile_src
switch(config-monitor)# source vlan 3, 6-8 tx
switch(config-monitor)# filter vlan 3-5, 7
switch(config-monitor)# destination interface ethernet 2/5
switch(config-monitor)# destination port-profile my_profile_dst
switch(config-monitor)# no shut
switch(config-monitor)# exit
switch(config)# show monitor session 1
switch(config)# copy running-config startup-config

switch(config)# show monitor session 1
  session 1
  -----
type          : local
state         : up
source intf   :
  rx          : Eth2/1
  tx          : Eth2/1
  both        : Eth2/1
source VLANs  :
  rx          :
  tx          : 3,6,7,8
  both        :
source port-profile :

```

## Example of Configuring a SPAN Session

```
rx          : my_profile_src
tx          : my_profile_src
both       : my_profile_src
filter VLANs : 3,4,5,7
destination ports : Eth3/1
destination port-profile : my_profile_dst
```

```
switch# module vse 3 execute vemcmd show span
```

```
VSE SOURCE IP NOT CONFIGURED.
```

HW	SSN	ID	ERSPAN	ID	HDR	VER	DST	LTL/IP
		1			local		49,51,52,55,56	