



Fax Detection

- [Overview, on page 1](#)
- [Restrictions for Fax Detection for SIP Call and Transfer on Cisco IOS XE, on page 2](#)
- [Information About Fax Detection for SIP Call and Transfer, on page 2](#)
- [Fax Detection with Cisco IOS XE High Availability, on page 5](#)
- [Fax Detection Configuration for SIP Calls, on page 5](#)
- [Configuration Examples for Fax Detection for SIP Calls, on page 11](#)

Overview

The fax detection feature detects whether an inbound call is from a fax machine. If the inbound call is from a fax machine, the call is rerouted appropriately.

Feature Information for Fax Detection for SIP Call and Transfer

The following table provides release information about the feature or features described in this module. This table lists only the software release that introduced support for a given feature in a given software release train. Unless noted otherwise, subsequent releases of that software release train also support that feature.

Use Cisco Feature Navigator to find information about platform support and Cisco software image support. To access Cisco Feature Navigator, go to www.cisco.com/go/cfn. An account on Cisco.com is not required.

Table 1: Feature Information for Fax Detection for SIP Call and Transfer

Feature Name	Releases	Feature Information
Fax Detection for SIP Call and Transfer	Cisco IOS 15.4(2)T	Fax detection is the capability to detect automatically whether an incoming call is voice or fax. For calls coming from an IP trunk to CUBE, the Fax Detection for SIP Call and Transfer feature is used to detect CNG tones (calling tones) so that the fax server can handle the actual fax transmission or redirect the fax call to a configured fax number. The following commands were introduced: cng-fax-detect and detect-fax mode .
Fax Detection for SIP Call and Transfer on Cisco IOS XE Platforms	Cisco IOS XE Amsterdam 17.2.1r	Support was introduced for SIP call and transfer for IP-to-IP calls on Cisco IOS XE platforms for Cisco Unified Border Element.

Restrictions for Fax Detection for SIP Call and Transfer on Cisco IOS XE

- The Fax Detect feature is supported with routers that are fitted with DSP modules.
- Only the g711ulaw and g711alaw codecs are used for detecting the fax CNG tone.
- Each destination number can be of maximum length of 32 characters.
- Fax Detection is supported with LTI-based transcoding.

Information About Fax Detection for SIP Call and Transfer

Fax detection is typically used if you need to have a single phone number for both voice and fax services. Incoming calls are initially answered by an auto attendant or interactive voice response (IVR) service. At this point, the media stream is monitored for fax tones. Calls identified as coming from a fax machine are then rerouted to a new destination, such as a fax server.

For Fax detection to work, the **cng-fax-detect** command under DSP farm and the **detect-fax** command must be configured in the inbound dial-peer. The fax detection feature may be configured to redirect calls to a local voice port or a remote application.



Note Fax detection on CUBE is also supported through a TCL script. The script answers an incoming call, plays a prompt and makes an outgoing voice or fax call. You can download the TCL script from the [CiscoDevNet Github](#).



Note If the **silence off** attribute is received in the SDP and the **fax protocol t38 version 0 ls-redundancy 0 hs-redundancy 0 fallback pass-through {g711alaw | g711ulaw}** codec command is configured, CUBE interprets the received SDP as a fax switchover call.

Local Redirect Mode

Local redirect may be used to transfer a fax call to either a local port or remote destination. Multiple destinations may be used if required, allowing the CUBE to hunt for the first available resource. The configured hunt list can include any number of destination ports.

Figure 1: Local Redirect Call Flow

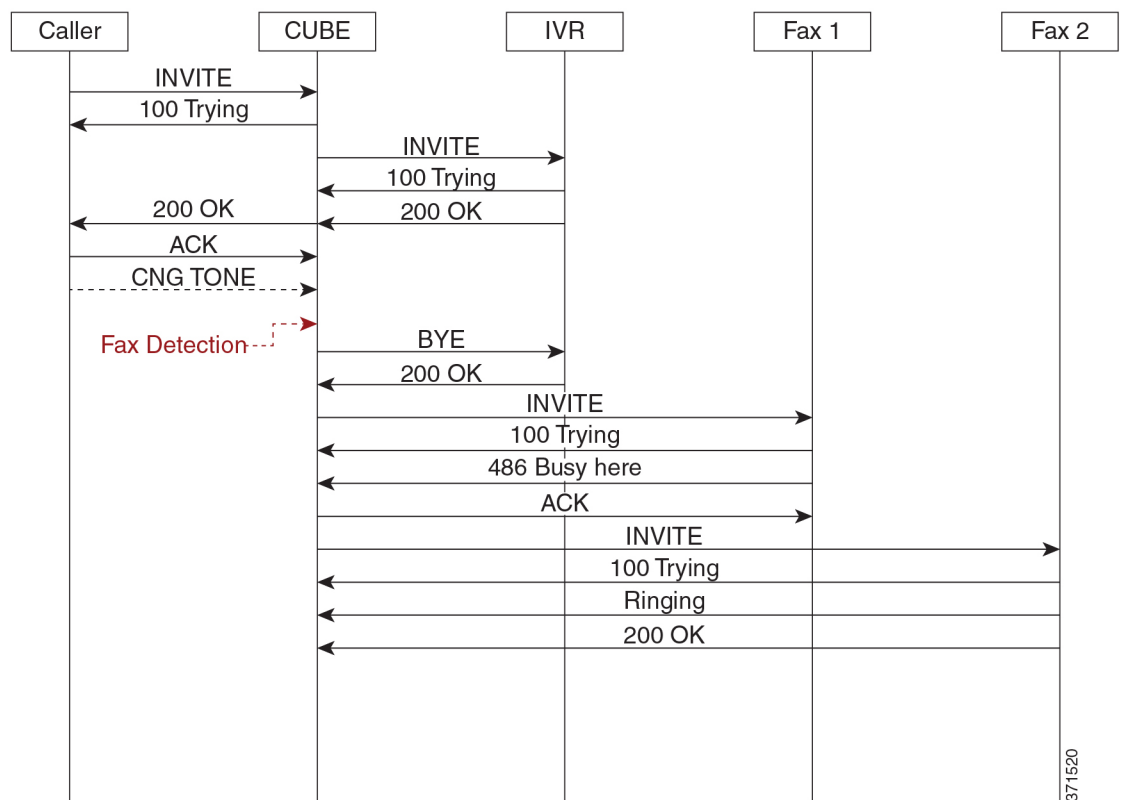

An initial connection is made as a voice call through CUBE to the IVR. On detection of fax tones in the media path, CUBE closes the connection to the IVR, then hunts through a list of numbers to establish a connection to a fax machine or fax server, allowing the originating fax machine to complete its transmission. In a scenario where T.38 is not supported by CUBE, it will fallback to passthrough.

For each call, a digital signal processor (DSP) channel is allocated to detect the fax CNG tone. This DSP remains allocated until the original call leg clears at the end of the call. In the call flow example above, the first fax machine is busy, so the CUBE establishes the call with the second fax machine.



Note For Local Redirect, new calls legs are negotiated as voice, not as fax session.

Refer Redirect Mode

In this mode, calls are redirected to a fax service by the original calling party. The redirect is based on information provided by CUBE in a SIP Refer message (similar to a blind transfer).

In this mode, only one redirection target can be configured.

Figure 2: Refer Redirect Call Flow

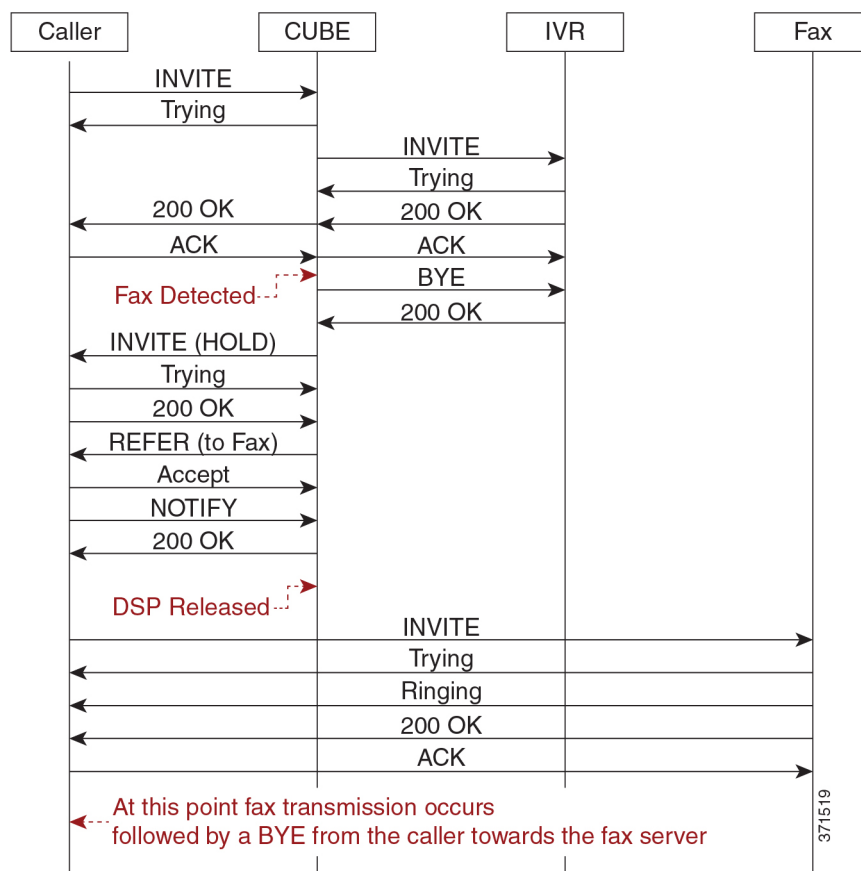

An initial connection is made as a voice call through CUBE to the IVR. On detection of fax tones in the media path, CUBE closes the connection to the IVR. To transfer the call, CUBE first sends a re-invite to put the original call leg on hold, then sends a SIP REFER with details of the remote fax server. From this point, CUBE is no longer involved in the call flow as the originating fax communicates directly with the destination server.

For each call, a DSP channel or resource is allocated to detect the CNG tone. This resource is released once the call transfer has been initiated.

Transcoder Behavior for Cisco IOS XE

For the fax tone detection support offered for Cisco IOS XE, the DSP resource behavior for local and refer redirect is as follows:

- For local redirect, CUBE doesn't release the transcoder until the fax call disconnects.
- For refer redirect, CUBE releases the transcoder when the REFER message is sent to the peer leg.

Fax Detection with Cisco IOS XE High Availability

Fax detection and transfer are supported with CUBE High Availability (HA) deployments. In this mode, two CUBE routers are configured to run in Active-Standby mode.

The following behaviors specific to this feature must be noted:

- Failover after initial call has been established, but fax hasn't been detected—The call is preserved, but tone detection is not available for the remainder of that call. The originating fax machine terminates the call after CNG time-out.
- Failover after fax detection, but before the transferred call leg is established—The initial call is preserved and the transfer fails. The originating fax machine terminates the call after CNG time-out.

Fax Detection Configuration for SIP Calls

Configure DSP Resource to Detect Fax Tone

SUMMARY STEPS

1. **enable**
2. **configure terminal**
3. **dspfarm profile *tag* transcode universal**
4. **cng-fax-detect**
5. **maximum sessions *sessions***
6. **associate application CUBE**
7. **end**

DETAILED STEPS

	Command or Action	Purpose
Step 1	enable Example: Device> enable	Enables privileged EXEC mode. <ul style="list-style-type: none"> • Enter your password if prompted.

	Command or Action	Purpose
Step 2	configure terminal Example: Device# configure terminal	Enters global configuration mode.
Step 3	dspfarm profile tag transcode universal Example: Device(config)# dspfarm profile 5 transcode universal	Enters DSP farm profile configuration mode and enables the profile for transcoding.
Step 4	cng-fax-detect Example: Device(config-dspfarm-profile)# cng-fax-detect	Enables CNG tone detection.
Step 5	maximum sessions sessions Example: Device(config-dspfarm-profile)# maximum sessions 6	Configures maximum number of sessions.
Step 6	associate application CUBE Example: Device(config-dspfarm-profile)# associate application CUBE	Configures an application to the profile for LTI-based transcoding.
Step 7	end Example: Device(config-dspfarm-profile)# end	Returns to privileged EXEC mode.

Dial-peer Configuration to Redirect Fax Call

SUMMARY STEPS

1. enable
2. configure terminal
3. dial-peer voice *number* voip
4. description *tag*
5. session protocol sipv2
6. incoming called number *number*
7. voice-class codec *tag*
8. no vad
9. detect-fax [mode { *refernumber*|*localnumber*}]

10. end

DETAILED STEPS

	Command or Action	Purpose
Step 1	enable Example: Device> enable	Enables privileged EXEC mode. <ul style="list-style-type: none"> • Enter your password if prompted.
Step 2	configure terminal Example: Device# configure terminal	Enters global configuration mode.
Step 3	dial-peer voice <i>number</i> voip Example: Device(config)# dial-peer voice 401 voip	Enters dial peer configuration mode for the specified VoIP dial peer.
Step 4	description <i>tag</i> Example: Device(config-dial-peer)# description Incoming dial-peer for Fax	Provides a description for the incoming dial-peer for Fax.
Step 5	session protocol sipv2 Example: Device(config-dial-peer)# session protocol sipv2	Configures SIP as the session protocol type.
Step 6	incoming called number <i>number</i> Example: Device(config-dial-peer)# incoming called-number 903309	Creates inbound dial-peer.
Step 7	voice-class codec <i>tag</i> Example: Device(config-dial-peer)# voice-class codec 111	Applies the previously configured voice class and associated codecs to a dial peer. The voice class codec can only include g711ulaw and g711alaw.
Step 8	no vad Example: Device(config-dial-peer)# no vad	Disables voice activity detection (VAD) for the calls using the dial peer being configured.
Step 9	detect-fax [<i>mode</i> { <i>refernumber</i> <i>localnumber</i> }] Example:	Defines fax detection as local or refer mode and refers to the directory number of the fax machine.

	Command or Action	Purpose
	Device(config-dial-peer)# detect-fax refer 12101	If local mode is configured, then a list of numbers, separated by a space may be entered. Refer mode only allows a destination number to be configured.
Step 10	end Example: Device(config-dial-peer)# end	Returns to privileged EXEC mode.

Verify Fax Detection Configuration for SIP Calls

SUMMARY STEPS

1. enable
2. show call active voice compact
3. show dspfarm dsp active

DETAILED STEPS

Step 1 enable

Example:

```
Device> enable
```

Enables privileged EXEC mode.

Step 2 show call active voice compact

Example:

This is a sample output of call setup when the call is connected:

```
Device# show call active voice compact
```

```

<callID>  A/O FAX T<sec> Codec      type      Peer Address      IP R<ip>:<udp>
Total call-legs: 3
      9   ANS  T4      g711ulaw  VOIP      P808808           9.42.25.145:17940
     10   ORG  T4      g711ulaw  VOIP      P309903           9.42.25.149:16396
     11   ANS  T4      g711ulaw  VOIP      P808808           9.42.25.149:16394

```

Step 3 show dspfarm dsp active

Example:

This is a sample output of the DSP channel reserved to detect CNG tone after the call is set up.

```
Device# show dspfarm dsp active
```

```

SLOT    DSP VERSION  STATUS CHNL USE  TYPE    RSC_ID BRIDGE_ID PKTS_TXED PKTS_RXED
  0      2    36.1.0    UP     1   USED   xcode    1      9      228      119

```



```

0      2  36.1.0  UP      1  USED  xcode  1      10      113      251
Total number of DSPFARM DSP channel(s) 1

```

Troubleshoot Fax Failures due to Multiple M-Lines on the CUBE

The CUBE doesn't understand multiple m-lines during a voice-to-fax switch-over. To resolve this issue, you can adopt the following workaround using Session Initiation Protocol (SIP) profiles.

Problem

When a provider sends an Invite message to the CUBE during a voice-to-fax switch-over, it includes a Session Description Protocol (SDP) with two m-lines. If the m-lines are in an unexpected format, then the CUBE fails to process it. As a result, it sends a malformed SDP to the fax server in the Invite message. Therefore, all calls fail.

Here is an example of an unaccepted m-line format:

m=image

m=audio

Solution

The workaround to troubleshoot fax failures due to multiple m-lines issue:

- Use only one m-line for the voice-to-fax switch-over.
- Use protocol-based pass-through.
- Have the provider place the *m=audio* line above the *m=image* line.
- Use the fax server in order to initiate the switch-over with the use of CNG in a T.30 indicator packet.

The CUBE version 10.0 uses a new feature for inbound SIP profiles. These profiles are applied to inbound SIP messages before it's presented to the SIP stack. The idea behind the use of the inbound SIP profiles in this scenario is to remove the *m=audio* line, so that the CUBE can work with a single *m=image* line.

Here is an example of the re-Invite message when the provider desires to escalate the voice call to fax:

```

Received:
INVITE sip:025027141@192.0.2.2:5060 SIP/2.0
Via: SIP/2.0/UDP 192.0.2.1:5060;branch=z9hG4bKnM30rd10dofho0fo9011sb0000g00.1
Call-ID: 6B6CB982-B41D11E3-898F851F-F1ADD198@192.0.2.2
From: <sip:026455288@25027100.xyz>;tag=7qapqh6u-CC-36
To: "Administrator" <sip:025027141@25027100.xyz>;tag=85A6C018-2489
CSeq: 1 INVITE
Contact: <sip:192.0.2.1:5060;transport=udp>
Max-Forwards: 69
Content-Length: 431
Content-Type: application/sdp
v=0
o=HuaweiSoftX3000 22157305 22157306 IN IP4 192.0.2.1
s=Sip Call
c=IN IP4 192.0.2.1
t=0 0
m=image 53200 udpt1 t38
a=T38FaxVersion:0

```

```

a=T38MaxBitRate:14400
a=T38FaxRateManagement:transferredTCF
a=T38FaxUdpEC:t38UDPRedundancy
m=audio 53190 RTP/AVP 8 0 101
a=rtpmap:8 PCMA/8000
a=rtpmap:0 PCMU/8000
a=rtpmap:101 telephone-event/8000
a=fmtp:101 0-15
a=ptime:20
a=silenceSupp:off - - - -
a=ecan:fb on -
a=X-fax

```

This SIP profile configuration can be applied in order to remove the *m=audio* line:

```

voice class sip-profiles 966
request REINVITE sdp-header Audio-Media modify "(.*)" "a=sendrecv"
voice service voip
sip
voice-class sip profiles 966 inbound
or
dial-peer voice XYZ voip
voice-class sip profiles 966 inbound

```

The SIP profile changes the *m=audio* line to *a=sendrecv*, which acts as a line in the SDP that isn't relevant. This allows the CUBE to send a re-Invite message to the fax server and await the *200 OK* response.

When sending a *200 OK* message as a response to the received re-Invite, it includes both m-lines that adhere to RFC standards. The response message contains the same number of media attributes as the offer message.

This can be accomplished using a standard outbound SIP profile that is applied on the dial-peer of the provider:

```

voice class sip-profiles 200
response 200 method re-invite sdp-header Attribute modify "t38UDPRedundancy"
"t38UDPRedundancy\x0D\x0Am=audio 0 RTP/AVP"

```

Replace the *"t38UDPRedundancy"* to ensure that the re-Invite with multiple m-lines is correctly handled and the response to the provider is RFC-compliant:

```

"t38UDPRedundancy"
New line ( \x0D\x0A )
m=audio 0 RTP/AVP

```

In order to resolve the issue of multiple m-lines, employ the workarounds that are discussed (most of which are provider-dependent). Also, it's observed that the Xmedius Server can initiate the switch-over, as it forces the server to send the T.38 re-Invite message avoiding multiple m-lines.

Fax Detection Troubleshooting for SIP Calls

You can enable the logs of the following **debug** or **show** commands, which are helpful in debugging fax detection for SIP calls:

- **debug voip ipipgw all**
- **debug ccsip verbose**
- **debug voip ccapi all**
- **debug voip dsmp all**
- **debug voip hpi all**
- **debug media resource provisioning all**

- **show call active voice compact**
- **show dspfarm dsp active**
- **show voip rtp connections**

Configuration Examples for Fax Detection for SIP Calls

Example: Configuring Local Redirect

The following is a sample configuration in local redirect mode for fax detection. In this example, the dial-peer has to be configured for the FAX directory numbers 9033010 and 9033011.

```
dspfarm profile 10 transcode universal
  codec g729abr8
  codec g729ar8
  codec g711alaw
  codec g711ulaw
  codec g729r8
  codec ilbc
  codec g722-64
  cng-fax-detect
  maximum sessions 6
  associate application CUBE
!
dial-peer voice 401 voip
  description "Incoming dial-peer to ASR"
  session protocol sipv2
  incoming called-number 903309
  voice-class codec 111
  dtmf-relay rtp-nte
  no vad
  detect-fax mode local 9033010 9033011

dial-peer voice 406 voip
  description "Outbound dialpeer for ..."
  destination-pattern 9033010
  session protocol sipv2
  session target ipv4:9.41.36.11:14762
  voice-class codec 111
  dtmf-relay rtp-nte
  fax protocol pass-through g711ulaw
  no vad

dial-peer voice 406 voip
  description "Outbound dialpeer for ..."
  destination-pattern 9033011
  session protocol sipv2
  session target ipv4:9.41.36.11:14765
  voice-class codec 111
  dtmf-relay rtp-nte
  fax protocol pass-through g711ulaw
  no vad
```

Example: Configuring Refer Redirect

In Refer mode, only one fax number can be configured.

```
dial-peer voice 401 voip
description "Incoming dial-peer to ASR"
session protocol sipv2
incoming called-number 903309
voice-class codec 111
dtmf-relay rtp-nte
no vad
detect-fax mode refer 9033010
```

```
dial-peer voice 406 voip
description "Outbound dialpeer for ..."
destination-pattern 9033010
session protocol sipv2
session target ipv4:9.41.36.11:14762
voice-class codec 111
dtmf-relay rtp-nte
fax protocol pass-through g711ulaw
no vad
```