



Cisco Wide Area Application Services Configuration Guide

Software Version 6.2.3
January 23, 2019

Cisco Systems, Inc.
www.cisco.com

Cisco has more than 200 offices worldwide.
Addresses, phone numbers, and fax numbers
are listed on the Cisco website at
www.cisco.com/go/offices.

THE SPECIFICATIONS AND INFORMATION REGARDING THE PRODUCTS IN THIS MANUAL ARE SUBJECT TO CHANGE WITHOUT NOTICE. ALL STATEMENTS, INFORMATION, AND RECOMMENDATIONS IN THIS MANUAL ARE BELIEVED TO BE ACCURATE BUT ARE PRESENTED WITHOUT WARRANTY OF ANY KIND, EXPRESS OR IMPLIED. USERS MUST TAKE FULL RESPONSIBILITY FOR THEIR APPLICATION OF ANY PRODUCTS.

THE SOFTWARE LICENSE AND LIMITED WARRANTY FOR THE ACCOMPANYING PRODUCT ARE SET FORTH IN THE INFORMATION PACKET THAT SHIPPED WITH THE PRODUCT AND ARE INCORPORATED HEREIN BY THIS REFERENCE. IF YOU ARE UNABLE TO LOCATE THE SOFTWARE LICENSE OR LIMITED WARRANTY, CONTACT YOUR CISCO REPRESENTATIVE FOR A COPY.

The Cisco implementation of TCP header compression is an adaptation of a program developed by the University of California, Berkeley (UCB) as part of UCB's public domain version of the UNIX operating system. All rights reserved. Copyright © 1981, Regents of the University of California.

NOTWITHSTANDING ANY OTHER WARRANTY HEREIN, ALL DOCUMENT FILES AND SOFTWARE OF THESE SUPPLIERS ARE PROVIDED "AS IS" WITH ALL FAULTS. CISCO AND THE ABOVE-NAMED SUPPLIERS DISCLAIM ALL WARRANTIES, EXPRESSED OR IMPLIED, INCLUDING, WITHOUT LIMITATION, THOSE OF MERCHANTABILITY, FITNESS FOR A PARTICULAR PURPOSE AND NONINFRINGEMENT OR ARISING FROM A COURSE OF DEALING, USAGE, OR TRADE PRACTICE.

IN NO EVENT SHALL CISCO OR ITS SUPPLIERS BE LIABLE FOR ANY INDIRECT, SPECIAL, CONSEQUENTIAL, OR INCIDENTAL DAMAGES, INCLUDING, WITHOUT LIMITATION, LOST PROFITS OR LOSS OR DAMAGE TO DATA ARISING OUT OF THE USE OR INABILITY TO USE THIS MANUAL, EVEN IF CISCO OR ITS SUPPLIERS HAVE BEEN ADVISED OF THE POSSIBILITY OF SUCH DAMAGES.

Cisco and the Cisco logo are trademarks or registered trademarks of Cisco and/or its affiliates in the U.S. and other countries. To view a list of Cisco trademarks, go to this URL: www.cisco.com/go/trademarks. Third-party trademarks mentioned are the property of their respective owners. The use of the word partner does not imply a partnership relationship between Cisco and any other company. (1721R)

Any Internet Protocol (IP) addresses used in this document are not intended to be actual addresses. Any examples, command display output, and figures included in the document are shown for illustrative purposes only. Any use of actual IP addresses in illustrative content is unintentional and coincidental.

Cisco Wide Area Application Services Configuration Guide
© 2006-2018 Cisco Systems, Inc. All rights reserved.



Preface	21
Audience	21
Document Organization	21
Document Conventions	23
Related Documentation	24
Obtaining Documentation and Submitting a Service Request	24

PART 1

Cisco WAAS Introduction and Planning

CHAPTER 1

Introduction to Cisco WAAS	1-1
About Cisco WAAS	1-1
Cisco WAAS Overcomes Common WAN Challenges	1-2
Key Services of Cisco WAAS	1-3
Traffic Optimization Process	1-3
Transport Flow Optimization	1-5
Window Scaling	1-5
TCP Initial Window Size Maximization	1-5
Increased Buffering	1-6
Selective Acknowledgment	1-6
Binary Increase Congestion TCP	1-6
Compression Technologies in Cisco WAAS	1-6
Application-Specific Acceleration Features in Cisco WAAS	1-7
Cisco WAAS Application Accelerators	1-7
File Services for Desktop Applications	1-8
File Services Features	1-8
Role of the Edge WAE	1-8
Role of the Core WAE	1-9
WAAS Print Services	1-9
Overview of Cisco WAAS Interfaces	1-9
WAAS Central Manager GUI	1-10
Accessing the WAAS Central Manager GUI	1-10
Components of the WAAS Central Manager GUI	1-11
WAAS Central Manager Menus	1-14

- WAAS Central Manager Taskbar Icons 1-15
- WAAS Central Manager Monitoring API 1-17
- WAAS CLI 1-17
- Benefits of Cisco WAAS 1-18
 - Preservation of Source TCP/IP Information 1-19
 - Autodiscovery of WAAS Devices 1-19
 - Centralized Network Monitoring and Management 1-19
 - Optimized Read and Write Caching 1-20
 - WCCP Support 1-20
 - PBR Support 1-21
 - Inline Interception Support 1-21
 - Failure Resiliency and Protection 1-21
 - RAID Compatibility 1-22
 - Streamlined Security 1-22
 - SNMP Support 1-22
 - IPv6 Support 1-23

CHAPTER 2

Planning Your WAAS Network 2-1

- Checklist for Planning Your WAAS Network 2-1
 - Planning Checklist 2-2
- Site and Network Planning 2-4
 - Windows Network Integration 2-5
 - Data Center WAE Integration 2-5
 - Branch WAE Integration 2-5
 - UNIX Network Integration 2-6
 - SMB-Related Ports in a WAAS Environment 2-6
 - Ports 139 and 445 2-6
 - Ports 88 and 464 2-7
 - Firewalls and Standby Central Managers 2-7
 - Performance Tuning for High WAN Bandwidth Branch Offices 2-7
- Overview of Autoregistration and WAEs 2-7
 - Selecting Static IP Addresses or Using Interface-Level DHCP 2-9
- Interoperability and Support 2-10
 - Unicode Support for WAAS GUI Interfaces 2-10
 - WAAS and Cisco IOS Interoperability 2-10
 - WAAS and the Cisco IOS QoS Classification Feature 2-11
 - WAAS and the Cisco IOS NBAR Feature 2-11
 - WAAS and Cisco IOS Marking 2-13
 - WAAS and Cisco IOS Queuing 2-13

WAAS and Cisco IOS Congestion Avoidance	2-13
WAAS and Cisco IOS Traffic Policing and Rate Limiting	2-13
WAAS and Cisco IOS Signaling	2-13
WAAS and Cisco IOS Link-Efficiency Operations	2-13
WAAS and Cisco IOS Provisioning, Monitoring, and Management	2-13
WAAS and Management Instrumentation	2-14
WAAS and MPLS	2-14
WAAS AOs Interoperability with Third-Party Load Balancers	2-14
WAAS Compatibility with Other Cisco Appliances and Software	2-15
WAAS Devices and Device Mode	2-15
Changing Device Mode	2-17
Calculating the Number of WAAS Devices Required	2-18
Supported Methods of Traffic Redirection	2-19
Advantages and Disadvantages of Using Inline Interception	2-20
Advantages and Disadvantages of Using WCCP	2-21
Advantages and Disadvantages of Using PBR	2-21
Configuring WCCP or PBR Routing for WAAS Traffic	2-22
Configuring WAEs as Promiscuous TCP Devices in a WAAS Network	2-25
Using Tertiary Interfaces or Subinterfaces to Connect WAEs to Routers	2-25
Access Lists on Routers and WAEs	2-26
IP ACLs on WAEs	2-26
Interception ACLs on WAEs	2-26
WAAS Login Authentication and Authorization	2-26
WAAS Administrator Accounts	2-27
Logically Grouping Your WAEs	2-28
Data Migration Process	2-29

PART 2**Installing and Configuring Cisco WAAS****CHAPTER 3****Using Device Groups and Device Locations 3-1**

About Device Groups	3-1
Working with Device Groups	3-2
Creating a Device Group	3-2
Creating a New Device Group	3-3
Configuring the Settings for a Device Group	3-4
Assigning Devices to a Configuration Device Group	3-5
Deleting a Device Group	3-6
Viewing Device Group Assignments	3-6

- Viewing the Device Groups List 3-7
- Enabling or Disabling Device Group Overlap 3-7
- Overriding Group Configuration Settings 3-7
 - Forcing Device Group Settings on All Devices in the Group 3-8
 - Selecting Device Group Precedence 3-9
 - Overriding the Device Group Settings on a Device 3-9
- Understanding the Impact of Assigning a Device to Multiple Device Groups 3-10
- Moving a Device Between Device Groups 3-10
- Working with Device Locations 3-11
 - Creating Locations 3-11
 - Deleting Locations 3-11
 - Viewing the Location Tree 3-12

CHAPTER 4

Configuring AppNav 4-1

- Information About Cisco AppNav 4-1
 - System Components 4-1
 - AppNav Controller Deployment Models 4-3
 - AppNav Controller Interface Modules 4-3
 - AppNav Policy 4-4
 - Class Maps 4-5
 - Policies 4-5
 - Nested Policies 4-6
 - Site and Application Affinity 4-6
 - Default Policy Behavior 4-9
- Prerequisites for AppNav Deployment 4-9
- Guidelines and Limitations for AppNav Deployment 4-10
- Configuring an AppNav Cluster 4-11
 - Task Flow for Configuring an AppNav Cluster 4-11
 - Configuring WAAS Device Interfaces 4-12
 - Interface Configuration with a Separate Management Interface 4-12
 - Interface Configuration with a Shared Management Interface 4-13
 - Interface Configuration Considerations 4-14
 - Creating a New AppNav Cluster with the AppNav Cluster Wizard 4-15
 - Creating a WAAS Appliance AppNav Cluster 4-16
 - Prerequisites for Creating an AppNav-XE Cluster 4-18
 - Configuring Interfaces with the Graphical Interface Wizard 4-20
 - Configuring AppNav Policies 4-22
 - Configuring a Class Map on a WAAS Appliance AppNav Cluster 4-22
 - Configuring Rules Within an AppNav Policy 4-28

Managing AppNav Policies	4-33
Configuring WAAS Node Optimization Policy	4-36
Configuring AppNav Controller ACLs	4-37
Configuring AppNav Cluster Settings	4-37
Configuring AppNav Controller Settings	4-39
Configuring AppNav Controller Settings for a WAAS Appliance	4-39
Configuring ANC Settings for an AppNav-XE Device	4-40
Configuring AppNav Contexts	4-41
Configuring WAAS Node Settings	4-42
Configuring WAAS Node Group Settings	4-43
Configuring AppNav Cluster Settings for a WAAS Node	4-44
Adding and Removing Devices from the AppNav Cluster	4-45
Adding an ANC to a Cluster	4-45
Removing or Disabling an ANC from a Cluster	4-47
Adding a New WAAS Node to the Cluster	4-47
Removing a WAAS Node from a Cluster	4-48
Adding a New WAAS Node Group to the Cluster	4-49
Removing a WAAS Node Group from a Cluster	4-49
Monitoring an AppNav Cluster	4-50
AppNav Connection Tracing	4-53
AppNav Connection Statistics	4-53

CHAPTER 5

Configuring Traffic Interception	5-1
Overview of Traffic Interception Methods	5-1
About Traffic Interception Methods	5-2
Guidelines for Configuring Traffic Interception	5-3
Overview of WCCP Interception	5-3
Guidelines for Configuring WCCP	5-5
Guidelines for File Server Access Methods	5-7
Configuring Advanced WCCP Features on Routers	5-7
Information About Configuring a Router to Support WCCP Service Groups	5-7
Configuring IP Access Lists on a Router	5-9
Setting a Service Group Password on a Router	5-10
Configuring a Loopback Interface on the Router	5-10
Configuring Router QoS for WCCP Control Packets	5-11
Configuring WCCP on WAEs	5-11
Information About Load Balancing and WAEs	5-11
Information About Packet-Forwarding Methods	5-14
Reasons for Packet Rejection and Return	5-15

- Layer 3 GRE as a Packet-Forwarding Method 5-15
- Layer 2 Redirection as a Packet-Forwarding Method 5-16
- Configuring or Viewing the WCCP Settings on WAEs 5-16
- Configuring or Viewing the WCCP Settings on ANCs 5-22
- Configuring and Viewing WCCP Router Lists for WAEs 5-25
- Configuring WAEs for a Graceful Shutdown of WCCP 5-26
- Configuring Static Bypass Lists for WAEs 5-26
- Configuring Interception Access Control Lists 5-27
- Configuring Egress Methods for WCCP-Intercepted Connections 5-29
 - Information About Egress Methods 5-29
 - Configuring the Egress Method 5-31
 - Configuring a GRE Tunnel Interface on a Router 5-31
- Using Policy-Based Routing Interception 5-33
 - Information About Policy-Based Routing 5-33
 - Configuring Policy-Based Routing 5-35
 - Methods of Verifying PBR Next-Hop Availability 5-39
 - Method 1: Using CDP to Verify Operability of WAEs 5-39
 - Method 2: Using IP SLAs to Verify WAE Operability Using ICMP Echo Verification 5-40
 - Method 3: Using IP SLAs to Verify WAE Operability Using TCP Connection Attempts 5-41
- Using Inline Mode Interception 5-42
 - Information About Inline Interception 5-42
 - Enabling Inline Operation on WAEs 5-44
 - Configuring Inline Interface Settings on WAEs 5-46
 - Configuring Inline Operation on ANCs 5-49
 - Configuring an IP Address on an Inline Interface 5-51
 - Configuring VLANs for Inline Support 5-53
 - Information About Clustering Inline WAEs 5-53
 - Disabling Peer Optimization Between Serial Inline WAEs 5-54
- Configuring AppNav Interception 5-56

CHAPTER 6

Configuring Network Settings 6-1

- Configuring Network Interfaces 6-1
 - Configuring a Standby Interface 6-3
 - Configuring a Standby Interface on a Device with Version 5.0 or Later 6-4
 - Configuring a Standby Interface on a Device Earlier than Version 5.0 6-5
 - Configuring Multiple IP Addresses on a Single Interface 6-7
- Modifying Ethernet Interface Settings 6-7
 - Modifying Physical Ethernet Interface Settings 6-7
 - Configuring Flow Control on 1 GB/s and Faster Ethernet Ports 6-10

Configuring the Default Gateway	6-11
Configuring Port-Channel Settings	6-12
Configuring a Port-Channel Interface on a Device with Version 5.0 or Later	6-13
Configuring a Port-Channel Interface on a Device Earlier than Version 5.0	6-14
Configuring a Load-Balancing Method for Port-Channel Interfaces	6-15
Configuring Interfaces for DHCP	6-16
Modifying Virtual Interface Settings for a vWAAS Device	6-17
Enabling or Disabling Optimization on WAAS Express Interfaces	6-18
Enabling WAAS Service Insertion on AppNav-XE Device Interfaces	6-20
Configuring Management Interface Settings	6-21
Configuring a Jumbo MTU	6-22
Configuring TCP Settings	6-23
Explicit Congestion Notification	6-24
Congestion Windows	6-24
Retransmit Time Multiplier	6-25
TCP Slow Start	6-25
Path MTU Discovery	6-26
Configuring a Static IP Route	6-26
Aggregating IP Routes	6-27
Configuring CDP Settings	6-27
Configuring the DNS Server	6-28
Configuring Windows Name Services	6-28
Configuring NAT Settings	6-29

CHAPTER 7**Configuring Administrative Login Authentication, Authorization, and Accounting 7-1**

About Administrative Login Authentication and Authorization	7-1
Default Administrative Login Authentication and Authorization Configuration	7-4
Configuring Administrative Login Authentication and Authorization	7-5
Configuring Login Access Control Settings for WAAS Devices	7-7
Configuring Secure Shell Settings for WAAS Devices	7-7
Disabling and Re-enabling the Telnet Service for WAAS Devices	7-10
Configuring Message-of-the-Day Settings for WAAS Devices	7-10
Configuring EXEC Timeout Settings for WAAS Devices	7-11
Configuring Line Console Carrier Detection for WAAS Devices	7-12
Configuring Remote Authentication Server Settings for WAAS Devices	7-12
Configuring RADIUS Server Authentication Settings	7-13
About TACACS+ Server Authentication Settings	7-15
Configuring TACACS+ Server Settings	7-16
Configuring Windows Domain Server Authentication Settings	7-17

- LDAP Server Signing 7-25
- Enabling Administrative Login Authentication and Authorization Schemes for WAAS Devices 7-27
- Configuring AAA Command Authorization 7-32
- Configuring Cisco Prime Network Control System Single Sign-On 7-33
- Configuring AAA Accounting for WAAS Devices 7-35
- Viewing Audit Trail Logs 7-36

CHAPTER 8

Creating and Managing Administrator User Accounts and Groups 8-1

- Overview of Administrator User Accounts 8-1
- Creating and Managing User Accounts 8-2
 - Overview for Creating an Account 8-2
 - Working with Accounts 8-3
 - Creating a New Account 8-4
 - Modifying and Deleting a User Account 8-5
 - Changing the Password for Your Own Account 8-6
 - Changing the Password for Another Account 8-7
 - Viewing a User Account 8-7
 - Unlocking a User Account 8-8
 - Working with Passwords 8-8
 - Working with Roles 8-9
 - Creating a New Role 8-10
 - Assigning a Role to a User Account 8-11
 - Modifying and Deleting a Role 8-12
 - Viewing Role Settings 8-13
 - Working with Domains 8-13
 - Creating a New Domain 8-14
 - Adding an Entity to a Domain 8-14
 - Assigning a Domain to a User Account 8-15
 - Modifying and Deleting a Domain 8-16
 - Viewing Domains 8-16
 - Working with User Groups 8-17
 - Creating a New User Group 8-17
 - Assigning Roles to a User Group 8-18
 - Assigning a Domain to a User Group 8-18
 - Modifying and Deleting a User Group 8-19
 - Viewing User Groups 8-19

CHAPTER 9

Creating and Managing IP Access Control Lists for Cisco WAAS Devices 9-1

- Overview of IP ACLs for WAAS Devices 9-1

Creating and Managing IP ACLs for WAAS Devices 9-2

List of Extended IP ACL Conditions 9-7

CHAPTER 10

Configuring Other System Settings 10-1

Modifying Device Properties 10-1

Managing Software Licenses 10-3

Enabling FTP Services 10-4

Configuring Date and Time Settings 10-5

 Configuring NTP Settings 10-5

 Configuring Time Zone Settings 10-5

Configuring Secure Store Settings 10-10

 Secure Store Overview 10-10

 Enabling Secure Store Encryption on the Central Manager 10-12

 Enabling Secure Store Encryption on a Standby Central Manager 10-13

 Enabling Secure Store Encryption on a WAE Device 10-14

 Changing Secure Store Passphrase Mode 10-14

 Changing the Secure Store Encryption Key and Password 10-15

 Resetting Secure Store Encryption on a Central Manager 10-16

 Disabling Secure Store Encryption on a WAE Device 10-17

Modifying the Default System Configuration Properties 10-18

Configuring the Web Application Filter 10-21

 Enabling the Web Application Filter 10-21

 Security Verification 10-22

 Input Validation 10-22

 Sanitization 10-22

Configuring Faster Detection of Offline WAAS Devices 10-23

 About Faster Detection of Offline Devices 10-24

Configuring Alarm Overload Detection 10-24

Configuring the E-mail Notification Server 10-25

Using IPMI over LAN 10-26

 Configuring BMC for Remote Platform Management 10-27

 Enabling IPMI Over LAN 10-27

 Enabling IPMI SoL 10-28

Managing Cisco IOS Router Devices 10-29

 Registering a Cisco IOS Router Device Using the Central Manager GUI 10-29

 Configuring Router Credentials 10-30

 Registering a Cisco IOS Router Using the CLI 10-31

 Configuring a User 10-32

- Importing the Central Manager Certificate 10-33
- Configuring a Router Certificate 10-34
- Enabling the HTTP Secure Server on the Router 10-34
- Installing a License on the Router 10-35
- Configuring an NTP Server 10-35
- Registering the Router 10-36
- Reimporting a Router Device Certificate 10-36
- Creating a new WAAS Central Manager IOS user on pre-registered IOS devices 10-37
- WAAS, ISR-WAAS, and IOS-XE Interoperability 10-37
- Configuring the Hostname for ISR-WAAS 10-38
 - About ISR-WAAS and ISR-WAAS Hostname 10-38
 - Configuring an ISR-WAAS Hostname with the Cisco WAAS CM 10-39
 - Configuring the ISR-WAAS Hostname with the CLI 10-40
 - Resetting an ISR-WAAS Hostname 10-40

PART 2

Configuring Cisco WAAS Services

CHAPTER 11

Configuring File Services 11-1

- About File Services 11-1
- Overview of the File Services Features 11-3
 - Automatic Discovery 11-3
 - Data Coherency 11-3
 - Data Concurrency 11-4
 - File-Locking Process 11-5
 - Prepositioning 11-5
 - Microsoft Interoperability 11-6
 - Windows Shadow Copy for Shared Folders 11-6
- Preparing for File Services 11-7
 - Using File Services on the Cisco WAAS Network Module (NME-WAE) 11-7
- Configuring File Services 11-7
 - Configuring the CIFS Accelerator 11-8
 - Creating Dynamic Shares for the CIFS Accelerator 11-8
 - About Preposition Directives 11-10
 - Creating a New Preposition Directive 11-11
 - Assigning Edge Devices to a Preposition Directive 11-14
 - Creating a New Preposition Schedule 11-15
 - Checking the Preposition Status 11-16
 - Starting and Stopping Preposition Tasks 11-16
 - Configuring the SMB Accelerator 11-16

About Preposition Directives	11-17
Creating a New Preposition Directive	11-18
Assigning Edge Devices to a Preposition Directive	11-22
Creating a New Preposition Schedule	11-23
Checking the Preposition Status	11-24
Creating Dynamic Shares for the SMB Accelerator	11-25

CHAPTER 12**Configuring Application Acceleration 12-1**

About Application Acceleration	12-1
Enabling and Disabling the Global Optimization Features	12-3
Procedure for Enabling and Disabling the Global Optimization Features	12-3
Configuring Individual Features and Application Accelerators	12-8
Configuring DRE Settings	12-8
Configuring HTTP Acceleration	12-9
About HTTP Metadata Caching	12-11
Using an HTTP Accelerator Subnet	12-11
Configuring MAPI Acceleration	12-12
Configuring Encrypted MAPI Acceleration	12-14
MAPI Operating Considerations	12-14
Terms Used with Microsoft Active Directory	12-14
Workflow for Configuring Encrypted MAPI	12-14
Configuring Encrypted MAPI Settings	12-15
Configuring a Machine Account Identity	12-17
Creating and Configuring a User Account	12-19
Configuring Microsoft Active Directory	12-21
Managing Domain Identities and Encrypted MAPI State	12-23
Cisco WAAS MAPI RPC over HTTP(S)	12-25
Microsoft Outlook and Exchange Versions Supported for Cisco WAAS MAPI RPC over HTTP(S)	12-25
Configuration pre-requisites for optimizing MAPI RPC over HTTP(S)	12-26
MAPI Acceleration Charts for Cisco WAAS MAPI RPC over HTTP(S)	12-26
Configuring SMB Acceleration	12-27
Configuring ICA Acceleration	12-31
Configuring ICA over SSL	12-33
Configuring SSL Acceleration	12-33
Prerequisites for Configuring SSL Acceleration	12-34
Configuring SSL Global Settings	12-36
Configuring a Service Certificate and Private Key	12-38
Working with Cipher Lists	12-42

- Working with Certificate Authorities 12-44
- Configuring SSL Management Services 12-48
- Configuring SSL Peering Service 12-50
- Using SSL Accelerated Services 12-52
- Updating a Certificate/Key in a SSL Accelerated Service 12-56
- Configuring SSL Acceleration for SaaS Applications 12-57
- Determining Server Domains Used by SaaS Applications 12-58
- Configuring SMART-SSL Accelerator 12-59
 - Preparing to use SMART-SSL acceleration 12-60
 - Using existing Root CA to sign WAAS accelerated service exported certificate 12-61
 - Creating Single-Sided SMART-SSL Accelerated Service Certificate 12-61
 - Configuring and enabling SMART-SSL accelerated services on single-sided device group 12-63
- office365 optimization using Azure vWAAS 12-64
- Cisco Support for Microsoft Windows Update 12-67
 - Benefits of Cisco Support for Microsoft Windows Update 12-68
 - Viewing Statistics for Cisco Support for Microsoft Windows Update 12-68
 - Cisco Support for Microsoft Windows Update and Akamai Cache Engine 12-69
- Creating a New Traffic Optimization Policy 12-69
 - Preparing to Create an Optimization Policy 12-70
 - Creating an Application Definition 12-70
 - Creating an Optimization Policy 12-71
 - Creating an Optimization Class Map 12-75
- Managing Application Acceleration 12-77
 - Modifying the Accelerator Load Indicator and CPU Load-Monitoring Threshold 12-77
 - Viewing a List of Applications 12-78
 - Viewing a Policy Report 12-79
 - Viewing a Class Map Report 12-79
 - Restoring Optimization Policies and Class Maps 12-80
 - Monitoring Applications and Class Maps 12-80
 - Defining Default DSCP Marking Values 12-80
 - Defining the Default DSCP Marking Value 12-81
 - Modifying the Position of an Optimization Policy 12-81
 - Modifying the Acceleration TCP Settings 12-83
 - Calculating the TCP Buffers for High BDP Links 12-84
 - Modifying the TCP Adaptive Buffering Settings 12-85

CHAPTER 13

- Configuring Cisco WAAS with Akamai Connect 13-1**
 - Benefits of Cisco WAAS with Akamai Connect 13-2
 - Deployment Options for Cisco WAAS with Akamai Connect 13-2

Dual-Sided Deployment	13-2
Single-Sided Deployment	13-3
Operating Considerations for Cisco WAAS with Akamai Connect	13-3
Supported WAAS Platforms for Akamai Connect	13-4
Supported WAAS Platforms for Akamai Connect up to 6,000 Connections	13-4
Supported WAAS Platforms for Akamai Connect beyond 6,000 Connections	13-5
WAVE and vWAAS Models for Akamai Connect beyond 6,000 Connections	13-5
Configuring HTTP-OC on WAVE-7541/7571/8541	13-6
Configuring HTTP-OC on vWAAS-12000/50000	13-8
Workflow for Enabling and Using Akamai Connect	13-10
Enabling Akamai Connect and Activating Akamai Connect License	13-10
Prerequisites for WAAS with Akamai Connect	13-11
Enabling Akamai Connect	13-11
Activating the Akamai Connect License	13-12
Deregistering and Reregistering a WAAS Device	13-14
Replacing an Inactive or Expired Akamai Connect License	13-15
Enabling Akamai Connected Cache	13-15
About Akamai Connected Cache	13-15
Akamai Connected Cache Requirements	13-16
Procedure for Enabling Akamai Connected Cache	13-16
Enabling OTT Caching	13-17
Overview of OTT Caching	13-17
About OTT Caching	13-17
Sites That Support OTT Caching	13-18
Workflow for OTT Caching with WAAS and Akamai Connect	13-18
Procedure for Enabling OTT Caching	13-19
Caching Types and Setting Caching Policies	13-19
Transparent Caching	13-19
Overview of Transparent Caching	13-20
Four Modes of Transparent Caching	13-20
Order of Preference for Caching Types	13-22
Setting Caching Policies	13-22
Using HTTP Proxy for Connections to the Akamai Network	13-23
Overview of HTTP Proxy Connections to the Akamai Network	13-23
Using the WAAS Central Manager as HTTP Proxy	13-24
Configuring External HTTP Proxy	13-25
Cisco Cloud Web Security and Force IMS Features	13-25
Configuring Cache Prepositioning for Akamai Connect	13-26
Overview of Cache Prepositioning for Akamai Connect	13-27

- Configuring a Cache Preposition Task 13-27
- Viewing Cache Prepositioning Task Status 13-30
- Copying Cache Prepositioning Tasks 13-31
- Configuring HTTP/S Preposition Proxy for Akamai Connect 13-32
 - Overview of HTTP/S Preposition Proxy for Akamai Connect 13-32
 - Configuring Global Proxy Host and Port for Preposition Tasks 13-32
 - Modifying Proxy Settings for an Individual Preposition Task 13-32
 - Removing Proxy Settings for an Individual Preposition Task 13-33
- Cisco Support for Microsoft Windows Update 13-33
 - Benefits of Cisco Support for Microsoft Windows Update 13-34
 - Viewing Statistics for Cisco Support for Microsoft Windows Update 13-34
 - Cisco Support for Microsoft Windows Update and Akamai Cache Engine 13-35

PART 2

Maintaining, Monitoring, and Troubleshooting your Cisco WAAS Network

CHAPTER 14

Maintaining Your WAAS System 14-1

- Upgrading the WAAS Software 14-1
 - Determining the Current Software Version 14-3
 - Obtaining the Latest Software Version from Cisco.com 14-3
 - Specifying the Location of the Software File in the WAAS Central Manager GUI 14-4
 - Upgrading the WAAS Central Manager 14-6
 - Upgrading Multiple Devices Using Device Groups 14-8
 - Upgrading Central Manager to New Hardware and Converting an Existing Central Manager to a WAE 14-8
 - Deleting a Software File 14-10
- Backing Up and Restoring Your WAAS System 14-10
 - Backing Up and Restoring the WAAS Central Manager Database 14-10
 - Backing Up and Restoring a WAE Device 14-12
 - Reinstalling the System Software 14-13
 - Preparing the USB Flash Drive 14-15
 - Reinstalling the System Software 14-16
 - Ensuring that RAID Pairs Rebuild Successfully 14-19
 - Recovering the System Software 14-19
 - Recovering a Lost Administrator Password 14-22
 - Recovering from Missing Disk-Based Software 14-23
 - Recovering WAAS Device Registration Information 14-24
- Performing Disk Maintenance for RAID-1 Systems 14-25
- Removing and Replacing Disks in RAID-5 Systems 14-26

Configuring the Central Manager Role	14-28
Converting a WAE to a Standby Central Manager	14-28
Converting a Primary Central Manager to a Standby Central Manager	14-29
Converting a Standby Central Manager to a Primary Central Manager	14-30
Switching Both the Central Manager Roles	14-30
Central Manager Failover and Recovery	14-31
Enabling Disk Encryption	14-32
Configuring a Disk Error-Handling Method	14-33
Enabling Data Cache Management	14-34
Activating All Inactive WAAS Devices	14-35
Rebooting a Device or Device Group	14-36
Performing a Controlled Shutdown	14-37

CHAPTER 15**Monitoring Your WAAS Network 15-1**

Viewing System Information from the System Dashboard Window	15-1
Monitoring Graphs and Charts	15-2
Viewing Device Information	15-3
Devices Window	15-3
Device Dashboard Window	15-5
Device Status Dashboard Window	15-7
Device Status Report	15-8
Viewing and Unlocking Device Users	15-9
Customizing a Dashboard or Report	15-9
The WAAS Central Manager Report Panel	15-9
Adding a Chart or Table	15-11
Configuring Chart Settings	15-12
WAAS Chart Descriptions	15-13
TCP Optimization Charts	15-14
Compression Summary	15-14
Compression Summary Over Time	15-14
Effective WAN Capacity	15-14
Throughput Summary	15-15
Traffic Summary	15-15
Traffic Summary Over Time	15-15
Traffic Volume and Reduction	15-16
Acceleration Charts	15-16
HTTP Acceleration Charts	15-16
HTTPS Acceleration Charts	15-17

Secure Sockets Layer (SSL) Acceleration Charts	15-18
Messaging Application Programming Interface (MAPI) Acceleration Charts	15-19
Network File System (NFS) Acceleration Charts	15-22
Server Message Block (SMB) Acceleration Charts	15-23
Independent Computing Architecture (ICA) Acceleration Charts	15-24
Akamai Connected Cache Charts	15-25
Connection Trend Charts	15-29
Optimized Connections Over Time	15-30
Optimized vs Pass-Through Connections	15-30
AppNav Charts	15-31
Total AppNav Traffic	15-31
AppNav Policies	15-31
Top 10 AppNav Policies	15-31
Top 10 WAAS Node Group Distribution	15-31
WAAS Node Group Distribution	15-31
Pass-Through Reasons	15-32
Top 10 Pass-Through Reasons	15-32
Platform Charts	15-32
CPU Utilization	15-32
Disk Utilization	15-32
WAAS Table Descriptions	15-32
Traffic Summary Table	15-33
Network Application Traffic Details Table	15-34
HTTP Acceleration Statistics Table	15-34
HTTPS Acceleration Statistics Table	15-35
ICA Acceleration Statistics Table	15-36
MAPI Acceleration Statistics Table	15-36
NFS Acceleration Statistics Table	15-37
SMB Acceleration Statistics Table	15-37
SSL Acceleration Statistics Table	15-38
Using Predefined Reports to Monitor WAAS	15-38
Predefined Reports Available by WAAS Level	15-39
Location-Level Reports	15-40
TCP Summary Report	15-41
HTTP Acceleration Report	15-41
HTTPS Acceleration Report	15-42
SSL Acceleration Report	15-42
MAPI Acceleration Report	15-42
NFS Acceleration Report	15-43
SMB Acceleration Report	15-43

ICA Acceleration Report	15-43
Summary Report	15-44
Topology Report	15-44
Connection Trend Report	15-45
Connections Statistics Report	15-45
Resource Utilization Report	15-46
Disks Report	15-46
AppNav Report	15-47
Exported Reports	15-47
Managing Reports	15-53
Creating a Custom Report	15-53
Viewing and Editing a Report	15-55
Scheduling a Report	15-55
Viewing or Deleting a Scheduled Report	15-57
Configuring Flow Monitoring	15-58
Configuring Flowing Monitoring with NetQoS	15-58
About Flow Monitoring with NetQoS	15-58
Configuration Considerations for Flow Monitoring with NetQoS	15-58
Procedure for Configuring Flow Monitoring with NetQoS	15-59
Example: Using NetQoS for Flow Monitoring	15-60
Configuring Flow Monitoring with NetFlow v9	15-60
About Flow Monitoring with NetFlow v9	15-61
Configuration Considerations for Flow Monitoring with NetFlow v9	15-61
Procedure for Configuring Flow Monitoring with NetFlow v9	15-61
Disabling NetFlow v9	15-62
NetFlow v9 Exported Fields	15-62
NetFlow v9 Pass-Through Reasons	15-64
Troubleshooting Flow Monitoring Information	15-65
Alarms for Flow Monitoring	15-65
Commands Used to Troubleshoot Flow Monitoring	15-66

CHAPTER 16**Troubleshooting Your WAAS Network 16-1**

WAAS Troubleshooting Guidelines	16-1
Gathering WAAS Troubleshooting Information	16-2
Rebooting the WAAS Device	16-3
Using the copy tech-support Command	16-3
Using show Commands	16-3
Using show Commands for WCCP Deployments	16-3
Generating a System Report	16-4

- Capturing and Analyzing Packets 16-4
- Verifying the WAAS Image 16-5
 - Verifying the Current WAAS Image 16-5
 - Verifying a Pending WAAS Image 16-6
- WAAS Central Manager Alarm Panel 16-6
 - Viewing the Alarm Panel 16-6
 - Acknowledging an Alarm 16-7
 - Filtering and Sorting Alarms 16-7
 - Device Alarms 16-8
- Troubleshooting Devices Using Alerts 16-8
- Using the show and clear Commands from the Central Manager 16-10
- Configuring and Viewing Logs 16-10
 - Configuring System Logging 16-10
 - Priority Levels 16-12
 - Multiple Hosts for System Logging 16-13
 - Configuring Transaction Logging 16-13
 - Enabling Transaction Logging 16-14
 - Transaction Logs 16-16
 - Viewing the System Message Log 16-16
 - Viewing the Audit Trail Log 16-17
 - Viewing a Device Log 16-17
 - CLI Commands for Verifying and Viewing Logs and System Image 16-17
- Using Diagnostic Tests 16-18
 - Device Diagnostics Using the Central Manager 16-18
 - Device Diagnostics Using the CLI 16-19
 - Akamai Connect Diagnostics Using the Central Manager 16-20
- Using the Kernel Debugger 16-22
- Using WAAS TCP Traceroute 16-22
- Verifying WAAS Physical Connectivity 16-23
 - Verifying Physical Connectivity Between Peer WAAS Devices 16-23
 - Verifying Physical Connectivity Between WAAS Data Center and Application Server Hosts 16-24
- Contacting Cisco Technical Support 16-24

CHAPTER 17

Configuring SNMP Monitoring 17-1

- Understanding SNMP 17-1
 - SNMP Communication Process 17-2
 - Supported SNMP Versions 17-3
 - SNMP Security Models and Security Levels 17-3

Cisco-Supported MIBs	17-4
About Cisco-Supported MIBs and CISCO-SMI	17-5
Types of MIB Output for SNMP Monitoring	17-5
MB Output for Statistical Data	17-5
MIB Output for Trend Data	17-6
Types of Cisco-Supported MIBs	17-6
Akamai Connect (CISCO-WAN-OPTIMIZATION-MIB)	17-7
Alarms (CISCO-CONTENT-ENGINE-MIB)	17-9
AOs (CISCO-WAN-OPTIMIZATION-MIB)	17-9
Applications (CISCO-WAN-OPTIMIZATION-MIB)	17-11
AppNav (CISCO-APPNAV-MIB)	17-12
Class Maps (CISCO-WAN-OPTIMIZATION-MIB)	17-15
Configuration (CISCO-CONFIG-MAN-MIB)	17-15
CPU and Memory (CISCO-PROCESS-MIB)	17-16
Devices (CISCO-CDP-MIB and CISCO-ENTITY-ASSET-MIB)	17-16
DRE Cache (CISCO-WAN-OPTIMIZATION-MIB)	17-17
DRE Performance (CISCO-WAN-OPTIMIZATION-MIB)	17-18
HTTP (CISCO-WAN-OPTIMIZATION-MIB)	17-18
Interfaces (IF-MIB)	17-19
IP Routing (IP-MIB, IP-FORWARD-MIB, MIB-II)	17-21
MAPI (CISCO-WAN-OPTIMIZATION-MIB)	17-22
NFS (CISCO-WAN-OPTIMIZATION-MIB)	17-23
Network Management (EVENT-MIB, HOST-RESOURCES-MIB)	17-23
Policy Maps (CISCO-WAN-OPTIMIZATION-MIB)	17-24
SMB (CISCO-WAN-OPTIMIZATION-MIB)	17-24
SNMP (ENTITY, ISNMP, and SNMP MIB Groups)	17-27
TFO (CISCO-WAN-OPTIMIZATION-MIB)	17-27
Downloading MIB Files	17-30
Using MIBs to Monitor WAAS	17-30
Using MIBs to Display Alarm Status	17-30
Using MIBs to Display AO Information and Status	17-30
Using MIBs to Display DRE Cache and Performance Information	17-31
Using MIBs to Display Interface Information	17-32
Using MIBs to Display TFO Information	17-32
Enabling the SNMP Agent on a WAAS Device	17-34
Checklist for Configuring SNMP	17-34
Preparing for SNMP Monitoring	17-35
Enabling SNMP Traps	17-35
Defining SNMP Triggers to generate User-Defined Traps	17-38

- Aggregating SNMP Triggers 17-40
- Specifying the SNMP Host 17-40
- Specifying the SNMP Community String 17-41
- Creating SNMP Views 17-42
- Creating an SNMP Group 17-43
- Creating an SNMP User 17-44
- Configuring SNMP Asset Tag Settings 17-46
- Configuring SNMP Contact Settings 17-47
- Configuring SNMP Trap Source Settings 17-47

APPENDIX A

Predefined Optimization Policy A-1

APPENDIX B

Transaction Log Format B-1

INDEX



Preface

This preface describes who should read the *Cisco Wide Area Application Services Configuration Guide*, how it is organized, and its document conventions. It contains the following sections:

- [Audience](#)
- [Document Organization](#)
- [Document Conventions](#)
- [Related Documentation](#)
- [Obtaining Documentation and Submitting a Service Request](#)

Audience

This guide is for experienced network administrators who are responsible for configuring and maintaining the Cisco Wide Area Application Services (WAAS) network.

You should be familiar with the basic concepts and terminology used in internetworking, and understand your network topology and the protocols that the devices in your network can use. You should also have a working knowledge of the operating systems on which you are running your WAAS network, such as Microsoft Windows, Linux, or Solaris.

Document Organization

This guide is organized as follows:

Chapter	Title	Description
Chapter 1	Introduction to Cisco WAAS	Provides an overview of the WAAS product and its features.
Chapter 2	Planning Your WAAS Network	Provides general guidelines and preparation information you should read before installing the WAAS product in your network.
Chapter 3	Using Device Groups and Device Locations	Describes how to create groups that make it easier to manage and configure multiple devices at the same time. This chapter also covers device locations.

Chapter	Title	Description
Chapter 4	Configuring AppNav	Describes how to configure your WAAS network using the AppNav deployment model.
Chapter 5	Configuring Traffic Interception	Describes the WAAS software support for intercepting all TCP traffic in an IP-based network.
Chapter 6	Configuring Network Settings	Describes how to configure interfaces and basic network settings like DNS and CDP.
Chapter 7	Configuring Administrative Login Authentication, Authorization, and Accounting	Describes how to centrally configure administrative login authentication, authorization, and accounting for WAEs in your WAAS network.
Chapter 8	Creating and Managing Administrator User Accounts and Groups	Describes how to create device-based CLI accounts and roles-based accounts from the WAAS Central Manager GUI.
Chapter 9	Creating and Managing IP Access Control Lists for Cisco WAAS Devices	Describes how to centrally create and manage Internet Protocol (IP) access control lists (ACLs) for your WAEs.
Chapter 10	Configuring Other System Settings	Describes how to perform various other system configuration tasks such as specifying an NTP server and setting the time zone on a device.
Chapter 11	Configuring File Services	Describes how to configure Common Internet File System acceleration, which allows branch office users to more efficiently access data stored at centralized data centers.
Chapter 12	Configuring Application Acceleration	Describes how to configure the application policies on your WAAS system that determine the types of application traffic that is accelerated over your WAN.
Chapter 13	Configuring Cisco WAAS with Akamai Connect	
Chapter 14	Maintaining Your WAAS System	Describes the tasks you may need to perform to maintain your WAAS system.
Chapter 15	Monitoring Your WAAS Network	Describes the monitoring tools available in the WAAS Central Manager GUI that provide detailed status information on your WAAS network.
Chapter 16	Troubleshooting Your WAAS Network	Describes the troubleshooting tools available in the WAAS Central Manager GUI that can help you identify and resolve issues with your WAAS network.
Chapter 17	Configuring SNMP Monitoring	Describes how to configure SNMP traps, recipients, community strings and group associations, user security model groups, and user access permissions.

Chapter	Title	Description
Appendix A	Predefined Optimization Policy	Lists the predefined applications and classifiers that WAAS will either optimize or pass through based on the policies that are provided with the system.
Appendix B	Transaction Log Format	Describes the transaction log format.

Document Conventions

Command descriptions use these conventions:

boldface font	Commands and keywords are in boldface.
<i>italic font</i>	Arguments for which you supply values are in italics.
[]	Elements in square brackets are optional.
[x y z]	Optional alternative keywords are grouped in brackets and separated by vertical bars.

Screen examples use these conventions:

<code>screen font</code>	Terminal sessions and information the switch displays are in screen font.
boldface screen font	Information you must enter is in boldface screen font.
<i>italic screen font</i>	Arguments for which you supply values are in italic screen font.
< >	Nonprinting characters, such as passwords, are in angle brackets.
[]	Default responses to system prompts are in square brackets.
!, #	An exclamation point (!) or a pound sign (#) at the beginning of a line of code indicates a comment line.

This document uses the following conventions:



Note

Means reader *take note*. Notes contain helpful suggestions or references to material not covered in the manual.



Caution

Means *reader be careful*. In this situation, you might do something that could result in equipment damage or loss of data.



Tip

Means *the following information will help you solve a problem*. Tips might not be troubleshooting or even an action, but could help you save time.

Related Documentation

For additional information on the Cisco WAAS software and hardware, see the following documentation:

- *Release Note for Cisco Wide Area Application Services*
- *Cisco Wide Area Application Services Upgrade Guide*
- *Cisco Wide Area Application Services Command Reference*
- *Cisco Wide Area Application Services Quick Configuration Guide*
- *Cisco Wide Area Application Services Configuration Guide* (this manual)
- *Cisco Wide Area Application Services API Reference*
- *Cisco WAAS Troubleshooting Guide for Release 4.1.3 and Later*
- *Cisco Wide Area Application Services Monitoring Guide*
- *Cisco Wide Area Application Services vWAAS Installation and Configuration Guide*
- *Configuring WAAS Express*
- *Cisco WAAS on Service Modules for Cisco Access Routers*
- *Configuring Cisco WAAS Network Modules for Cisco Access Routers*
- *WAAS Enhanced Network Modules*
- *Regulatory Compliance and Safety Information for the Cisco Wide Area Virtualization Engines*
- *Cisco Wide Area Virtualization Engine 294 Hardware Installation Guide*
- *Cisco Wide Area Virtualization Engine 594 and 694 Hardware Installation Guide*
- *Cisco Wide Area Virtualization Engine 7541, 7571, and 8541 Hardware Installation Guide*
- *Regulatory Compliance and Safety Information for the Cisco Content Networking Product Series*
- *Installing the Cisco WAE Inline Network Adapter*

Obtaining Documentation and Submitting a Service Request

For information on obtaining documentation, submitting a service request, and gathering additional information, see the monthly *What's New in Cisco Product Documentation*, which also lists all new and revised Cisco technical documentation, at:

<http://www.cisco.com/en/US/docs/general/whatsnew/whatsnew.html>

Subscribe to the *What's New in Cisco Product Documentation* as a Really Simple Syndication (RSS) feed and set content to be delivered directly to your desktop using a reader application. The RSS feeds are a free service and Cisco currently supports RSS version 2.0.



PART 1

Cisco WAAS Introduction and Planning



Introduction to Cisco WAAS

This chapter provides an overview of the Cisco Wide Area Applications Services (WAAS) solution and describes the main features that enable Cisco WAAS to overcome the most common challenges in transporting data over a wide area network.



Note

Throughout this chapter, the term Cisco WAAS device is used to refer collectively to the WAAS Central Managers and Cisco Wide Area Application Engines (WAEs) in your network. The term WAE refers to WAE and Cisco Wide Area Virtualization Engine (WAVE) appliances, Cisco Services-Ready Engine service modules (SRE-SMs) running WAAS, and Cisco Virtual WAAS (vWAAS) instances.

This chapter contains the following sections:

- [About Cisco WAAS](#)
- [Key Services of Cisco WAAS](#)
- [Overview of Cisco WAAS Interfaces](#)
- [Benefits of Cisco WAAS](#)

About Cisco WAAS

The WAAS system consists of a set of devices called WAEs that work together to optimize TCP traffic over your network. When client and server applications attempt to communicate with each other, the network intercepts and redirects this traffic to the WAEs so that they can act on behalf of the client application and the destination server. The WAEs examine the traffic and use built-in optimization policies to determine whether to optimize the traffic or allow it to pass through your network unoptimized.

WAAS Version 5.0 introduced a new AppNav deployment model that greatly reduces dependency on the intercepting switch or router by taking on the responsibility of distributing traffic among WAAS devices for optimization. WAAS appliances with AppNav Controller Interface Modules operate in a special AppNav Controller mode, with AppNav policies controlling traffic flow to WAAS devices performing optimization. The AppNav model is well suited for data center deployments and addresses many of the WAN optimization challenges in this environment.



Note

You can deploy WAAS in either the new AppNav model, or in the traditional model without using AppNav Controllers.

Use the WAAS Central Manager GUI to centrally configure and monitor the WAEs and optimization policies in your network. You can also use the WAAS Central Manager GUI to create new optimization policy rules so that the WAAS system can optimize both custom applications and less common applications.

Cisco WAAS helps enterprises meet the following objectives:

- Provide branch office employees with LAN-like access to information and applications across a geographically distributed network.
- Migrate application and file servers from branch offices into centrally managed data centers.
- Minimize unnecessary WAN bandwidth consumption through the use of advanced compression algorithms.
- Improve application performance over the WAN by addressing the following common issues:
 - Low data rates (constrained bandwidth)
 - Slow delivery of frames (high network latency)
 - Higher rates of packet loss (low reliability)

Note

A WAAS Express device, which is a Cisco router with WAAS Express functionality enabled, can interoperate with other WAAS devices. A WAAS Express device provides basic WAN optimization and some application optimization, but no virtualization. For more information on WAAS Express, see [Configuring WAAS Express](#).

A device having the AppNav-XE component, typically, a Cisco router or virtual Cloud Services Router with virtual AppNav functionality, can interoperate with other WAAS devices that are acting as WAAS nodes. Such a device acts as an AppNav Controller that distributes traffic to other WAAS devices acting as WAAS nodes that optimize the traffic. However, a device with the AppNav-XE component cannot interoperate with other AppNav Controller hardware appliances. For more information on AppNav-XE, see the AppNav-XE documentation. For more information on AppNav, see [Chapter 4, “Configuring AppNav.”](#)

A vWAAS instance is a virtual WAAS appliance running on a VMware virtual machine and providing all of the same features as a WAAS appliance. A WAAS Central Manager can manage WAEs, WAAS Express devices, and vWAAS instances all in the same WAAS network. For more information on vWAAS, see the [Cisco Wide Area Application Services vWAAS Installation and Configuration Guide](#).

Cisco ISR-WAAS is a virtualized WAAS instance running on a Cisco ISR router. It provides added optimization without the need for additional hardware or external appliances. A WAAS Central Manager can monitor and configure Cisco ISR-WAAS.

This section contains the following topics:

- [Cisco WAAS Overcomes Common WAN Challenges](#)
- [Traffic Optimization Process](#)

Cisco WAAS Overcomes Common WAN Challenges

[Table 1-1](#) describes how Cisco WAAS uses a combination of TCP optimization techniques and application acceleration features to overcome the most common challenges associated with transporting traffic over a WAN.

Table 1-1 Cisco WAAS Solution

WAN Issue	Cisco WAAS Solution
High network latency	Intelligent protocol adapters reduce the number of round-trip responses common with chatty application protocols.
Constrained bandwidth	Data caching provided with the file services feature and data compression reduce the amount of data sent over the WAN, which in turn, increases data transfer rates. These solutions improve application response time on congested links by reducing the amount of data sent across the WAN.
Poor link utilization	TCP optimization features improve network throughput by reducing the number of TCP errors sent over the WAN and maximizing the TCP window size that determines the amount of data that a client can receive at one time.
Packet loss	Optimized TCP stack in WAAS overcomes the issues associated with high packet loss and protects communicating end points from the state of the WAN.

Key Services of Cisco WAAS

Cisco WAAS contains the following services that help optimize traffic over your wide area network:

- [Traffic Optimization Process](#)
- [Transport Flow Optimization](#)
- [Compression Technologies in Cisco WAAS](#)
- [Application-Specific Acceleration Features in Cisco WAAS](#)
- [File Services for Desktop Applications](#)
- [WAAS Print Services](#)



Note

WAAS Express devices provide basic optimization and compression services and some application acceleration.

Traffic Optimization Process

Figure 1-1 shows the process that Cisco WAAS follows to optimize application traffic.

Figure 1-1 Traffic Optimization Process

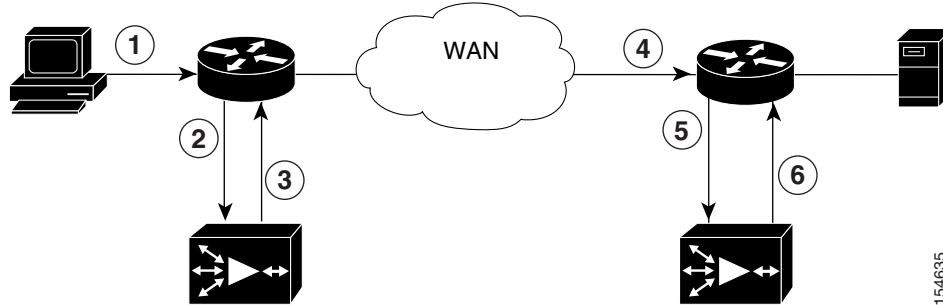

The following steps describe how your WAAS network optimizes a connection between a branch office client and a destination server:

1. A branch office client attempts to connect to the destination server over the native application port.
2. The WAAS network uses (Web Cache Communication Protocol (WCCP) or policy-based routing (PBR) to intercept the client request, or if deployed on an inline WAE, WAAS can intercept the request directly, using inline mode. For more information on inline mode, see [Using Inline Mode Interception](#) in Chapter 5, “Configuring Traffic Interception.”
3. The branch WAE performs the following actions:
 - Examines the parameters in the traffic’s TCP headers and then refers to the optimization policies to determine if the intercepted traffic should be optimized. Information in the TCP header, such as the source and destination IP address and port, allows the branch WAE to match the traffic to an optimization policy rule. For a list of predefined policy rules, see [Appendix A, “Predefined Optimization Policy.”](#)
 - If the branch WAE determines that the traffic should be optimized, it adds information to the TCP header informs the next WAE in the network path to optimize the traffic.
4. The branch WAE passes along the client request through the network to its original destination server.
5. The data center WAE performs the following actions:
 - Intercepts the traffic going to the destination server.
 - Establishes an optimized connection with the branch WAE. If the data center WAE has optimization disabled, an optimized connection is not established, and the traffic passes over the network unoptimized.

In an AppNav deployment, an AppNav Controller intercepts the traffic in the data center and distributes it to a WAAS node that establishes an optimized connection with the branch WAE. For more information on AppNav deployment, see [Chapter 4, “Configuring AppNav.”](#)
6. WAAS optimizes subsequent traffic between the branch WAE and data center WAE for this connection.

Cisco WAAS does not optimize traffic in the following situations:

- The WAE intercepts non-TCP traffic (such as UDP or ICMP).
- The WAE is overloaded and does not have the resources to optimize traffic.
- The intercepted traffic matches an optimization or AppNav policy rule that specifies that traffic can be passed through unoptimized.

**Note**

If unoptimized traffic reaches a WAE, the WAE forwards the traffic in pass-through mode without affecting the performance of the application using the passed-through connection.

Transport Flow Optimization

Cisco WAAS uses a variety of transport flow optimization (TFO) features to optimize TCP traffic intercepted by the WAAS devices. TFO protects communicating clients and servers from negative WAN conditions, such as bandwidth constraints, packet loss, congestion, and retransmission.

TFO includes the following optimization features:

- [Window Scaling](#)
- [TCP Initial Window Size Maximization](#)
- [Increased Buffering](#)
- [Selective Acknowledgment](#)
- [Binary Increase Congestion TCP](#)

Window Scaling

Window scaling allows the receiver of a TCP packet to advertise that its TCP receive window can exceed 64 KB. The receive window size determines the amount of space that the receiver has available for unacknowledged data. By default, TCP headers limit the receive window size to 64 KB, but Windows scaling allows the TCP header to specify receive windows of up to 1 GB.

Window scaling allows TCP endpoints to take advantage of available bandwidth in your network and not be limited to the default window size specified in the TCP header.

For more information about Window scaling, refer to For more information on vWAAS, see the [RFC 1323](#).

TCP Initial Window Size Maximization

WAAS increases the upper bound limit for TCP's initial window from one or two segments to two to four segments (approximately 4 KB). Increasing TCP's initial window size provides the following advantages:

- When the initial TCP window is only one segment, a receiver that uses delayed ACKs is forced to wait for a timeout before generating an ACK response. With an initial window of at least two segments, the receiver generates an ACK response after the second data segment arrives, eliminating the wait on the timeout.
- For connections that transmit only a small amount of data, a larger initial window reduces the transmission time. For many e-mail (SMTP) and web page (HTTP) transfers that are less than 4 KB, the larger initial window reduces the data transfer time to a single round-trip time (RTT).
- For connections that use large congestion windows, the larger initial window eliminates up to three RTTs and a delayed ACK timeout during the initial slow-start phase.

For more information about this optimization feature, see WAAS, see the [RFC 3390](#).

Increased Buffering

Cisco WAAS enhances the buffering algorithm used by the TCP kernel so that WAEs can pull data from branch office clients and remote servers more aggressively. This increased buffer helps the two WAEs participating in the connection keep the link between them full, thus increasing link utilization.

Selective Acknowledgment

Selective Acknowledgement (SACK) is an efficient packet loss recovery and retransmission feature that allows clients to recover from packet losses more quickly, compared to the default recovery mechanism used by TCP.

By default, TCP uses a cumulative acknowledgment scheme that forces a sender to either wait for a round-trip to learn if packets were not received by a recipient, or to unnecessarily retransmit segments that may have been correctly received.

SACK allows the receiver to inform the sender about all the segments that have arrived successfully, so that the sender needs to retransmit only the segments that have actually been lost.

For more information about SACK, see [RFC 2018](#).

Binary Increase Congestion TCP

Binary Increase Congestion (BIC) TCP is a congestion management protocol that allows your network to recover more quickly from packet loss events.

When your network experiences a packet loss event, BIC TCP reduces the receiver's window size and sets that reduced size as the new value for the minimum window. BIC TCP then sets the maximum window size value to the size of the window just before the packet loss event occurred. Because packet loss occurred at the maximum window size, the network can transfer traffic without dropping packets whose size falls within the minimum and maximum window size values.

If BIC TCP does not register a packet loss event at the updated maximum window size, that window size becomes the new minimum. If a packet loss event does occur, that window size becomes the new maximum. This process continues until BIC TCP determines the new optimum minimum and maximum window size values.

Compression Technologies in Cisco WAAS

Cisco WAAS uses the following compression technologies to help reduce the size of data transmitted over your WAN:

- Data Redundancy Elimination (DRE)
- Lempel-Ziv (LZ) compression

These compression technologies reduce the size of transmitted data by removing redundant information before sending the shortened data stream over the WAN. By reducing the amount of transferred data, WAAS compression helps reduce network utilization and application response times.

When a WAE uses compression to optimize TCP traffic, it replaces repeated data in the stream with a much shorter reference, and then sends the shortened data stream out across the WAN. The receiving WAE uses its local redundancy library to reconstruct the data stream before passing it along to the destination client or server.

The WAAS compression scheme is based on a shared cache architecture where each WAE involved in compression and decompression shares the same redundancy library. When the cache that stores the redundancy library on a WAE becomes full, WAAS uses a FIFO algorithm to discard old data and make room for new.

LZ compression operates on smaller data streams and maintains limited compression history. DRE operates on significantly larger streams (typically tens to hundreds of bytes or more) and maintains a much larger compression history. Large chunks of redundant data is common in file system operations when files are incrementally changed from one version to another or when certain elements are common to many files, such as file headers and logos.

Application-Specific Acceleration Features in Cisco WAAS

In addition to the TCP optimization features that speed the flow of traffic over a WAN, Cisco WAAS includes these application acceleration features:

- Operation prediction and batching—Allows a WAAS device to transform a command sequence into a shorter sequence over the WAN to reduce roundtrips.
- Intelligent message suppression—Decreases the response time of remote applications. Even though TFO optimizes traffic over a WAN, protocol messages between branch office clients and remote servers can still cause slow application response time. To resolve this issue, each WAAS device contains application proxies that can respond to messages locally so that the client does not have to wait for a response from the remote server. The application proxies use a variety of techniques, including caching, command batching, prediction, and resource prefetch to decrease the response time of remote applications.

Cisco WAAS uses application-intelligent software modules to apply these acceleration features.

Cisco WAAS Application Accelerators

The following WAAS application accelerators are available:

- SMB—Accelerates SMB traffic exchanged with a remote file server. Supports SMB 1.0, 2.0, and 2.1 protocols for signed SMB traffic. For more information, see [File Services for Desktop Applications](#).
- NFS—Accelerates Network File System (NFS) version 3 traffic exchanged with a remote file server. Secure NFS traffic is not accelerated.
- ICA—Accelerates Independent Computing Architecture (ICA) traffic that is used to access a Virtual Desktop Infrastructure (VDI).
- HTTP—Accelerates HTTP and HTTPS traffic.
- SSL—Accelerates encrypted Secure Sockets Layer (SSL) and Transport Layer Security (TLS) traffic. The SSL accelerator provides traffic encryption and decryption within WAAS to enable end-to-end traffic optimization. The SSL accelerator also provides secure management of the encryption certificates and keys.
- MAPI—Accelerates Microsoft Outlook Exchange traffic that uses the Messaging Application Programming Interface (MAPI) protocol. Microsoft Outlook 2000–2010 clients are supported. Secure connections that use message authentication (signing) or encryption are accelerated. MAPI over HTTP is not accelerated.

- Windows Print—Accelerates print traffic between clients and a Windows print server located in the data center. Signed Server Message Block (SMB) traffic is optimized by transport-level optimizations (TFO, DRE, and LZ). The Windows print accelerator supports Windows 2000, Windows Server 2003, Windows Server 2008, and Windows Server 2008 R2 print servers. It supports clients running Windows 2000, Windows XP, Windows Vista, and Windows 7.

**Note**

WAAS Express devices provide application acceleration for SMB, HTTP, and SSL traffic.

To enable or disable application accelerators, see [Enabling and Disabling the Global Optimization Features](#) in Chapter 12, “Configuring Application Acceleration.”

You must enable the accelerator on both of the peer WAEs at either end of a WAN link for all application accelerators to operate.

File Services for Desktop Applications

The file services (SMB accelerators) feature allows a WAE to fulfill a client’s requests more quickly instead of sending every request over the WAN to the file server. By fulfilling a client’s requests locally, the WAE minimizes the traffic sent over the WAN and reduces the time it takes branch office users to access files and many desktop applications, allowing enterprises to consolidate their important information in data centers. For more information, see [Chapter 11, “Configuring File Services.”](#)

**Note**

Legacy-mode Wide Area File Services (WAFS) are no longer supported. Legacy WAFS users must migrate to the SMB accelerator.

This section contains the following topics:

- [File Services Features](#)
- [Role of the Edge WAE](#)
- [Role of the Core WAE](#)

File Services Features

File Services include the following features:

- Data coherency and concurrency—Ensures data integrity across the WAAS system by managing the freshness of the data (coherency) and controlling the access to data by multiple clients (concurrency).
- Automatic discovery—Allows you to use file services without having to register individual file servers in the WAAS Central Manager. With the automatic discovery feature, the WAAS device will automatically discover and connect to a new file server when a SMB request is received.

Role of the Edge WAE

The Edge WAE is a client-side, file-caching device that serves client requests at remote sites and branch offices. The device is deployed at each branch office or remote campus, replacing file and print servers and giving local clients fast, near-LAN read and write access to a cached view of the centralized storage.

By caching the data most likely to be used at these sites, Edge WAEs greatly reduce the number of requests and the volume of data that must be transferred over the WAN between the data center and the edge.

When requests for data that is not located in the cache are received, the Edge WAE encapsulates the original SMB request using a TCP/IP-based protocol, compresses it, and sends it over the WAN to the Core WAE. Data returned from the data center is distributed by the Edge WAE to the end user who requested it.

Role of the Core WAE

The Core WAE is a server-side component that resides at the data center and connects directly to one or more file servers or network-attached storage (NAS). Core WAEs are placed between the file servers at the data center and the WAN connecting the data center to the enterprise's remote sites and branch offices. Requests received from Edge WAEs over the WAN are translated by the Core WAE into its original file server protocol and forwarded to the appropriate file server. The data center Core WAEs can provide load balancing and failover support.

When the data is received from the file server, the Core WAE encapsulates and compresses it before sending it over the WAN back to the Edge WAE that requested it. Core WAEs can be arranged in logical clusters to provide scalability and automatic failover capabilities for high-availability environments.

WAAS Print Services

The WAAS software includes the following print services options:

- Windows print accelerator—Use this option when you have a print server in a data center and branch clients are printing to local or remote printers. This service accelerates print traffic between clients and a Windows print server located in the data center. This option requires no configuration, but does require that both the SMB application accelerator and Windows print acceleration be enabled. For more information, see [Enabling and Disabling the Global Optimization Features](#) in Chapter 12, “Configuring Application Acceleration.”



Note The Legacy Print Services feature is no longer supported. Users of Legacy Print Services must migrate to another print services option.

These services eliminate the need for a separate hardware print server in the branch office. WAAS print services are available for Windows clients and work with any IP-based network printer.

Overview of Cisco WAAS Interfaces

The Cisco WAAS software provides the following interfaces to help you manage, configure, and monitor the various elements of your WAAS network:

- [WAAS Central Manager GUI](#)
- [WAAS Central Manager Monitoring API](#)
- [WAAS CLI](#)

WAAS Central Manager GUI

Every WAAS network must have one primary WAAS Central Manager device that is responsible for managing the other WAAS devices in your network. The WAAS Central Manager device hosts the WAAS Central Manager GUI, a Web-based interface that allows you to configure, manage, and monitor the WAAS devices in your network. The WAAS Central Manager resides on a dedicated WAE device.

The WAAS Central Manager GUI allows administrators to perform the following tasks:

- Configure system and network settings for an individual WAAS device, vWAAS device, WAAS Express device, device group, AppNav Controller, and AppNav Cluster.
- Create and edit optimization policies that determine the action that a WAAS device performs when it intercepts specific types of traffic.
- Create and edit AppNav policies that determine how AppNav Controllers distribute traffic to optimizing WAAS nodes.
- Configure file services.
- Create device groups that help you manage and configure multiple WAEs at the same time.
- View detailed reports about the optimized traffic in your WAAS network.

**Note**

You cannot enable optimization and application acceleration services on a WAE that has been configured as a WAAS Central Manager. The purpose of the WAAS Central Manager is to configure, monitor, and manage the WAEs in your network.

This section contains the following topics:

- [Accessing the WAAS Central Manager GUI](#)
- [Components of the WAAS Central Manager GUI](#)
- [WAAS Central Manager Menus](#)
- [WAAS Central Manager Taskbar Icons](#)

Accessing the WAAS Central Manager GUI

To access the WAAS Central Manager GUI, enter the following URL in your web browser:

`https://WAE_Address:8443/`

The *WAE_Address* value is the IP address or hostname of the WAAS Central Manager device.

If the Central Manager has been configured with an IPV6 address, it can be accessed using `https://[CM ipv6 address]:8443/`

The default administrator username is *admin* and the password is *default*. For information on creating accounts and changing passwords, see [Chapter 8, “Creating and Managing Administrator User Accounts and Groups.”](#)

Ensure that your web browser is set to use Unicode (UTF-8) character encoding.

When using Internet Explorer to access the Central Manager GUI, you may see a “Choose a digital certificate” dialog. Click **Cancel** to proceed to the Central Manager login screen.

You may also see a browser security warning that there is a problem with the website’s security

certificate. This happens because the Central Manager uses a self-signed certificate. Click on the link **Continue to this website (not recommended)**. You can permanently install the certificate to avoid this error in the future.

To install the certificate in Internet Explorer 8, click the red **Certificate Error** button in the address bar and choose **View Certificates**. Click **Install Certificate**, then click **Next**. Select Automatically select the certificate store based on the type of certificate and click **Next**, click **Finish**, then click **Yes** on the security warning, click **OK** on the acknowledgement, and click **OK** on the Certificate dialog. The certificate installation procedure differs depending on the browser.

If you are using Internet Explorer to access the Central Manager GUI, we strongly recommend that you install the Google Chrome Frame plug-in for better performance. When you log in to the Central Manager the first time, you are prompted to install Google Chrome Frame. Choose a language, click **Get Google Chrome Frame**, and follow the prompts to download and install the plug-in. If you do not want to install the plug-in, click the link to continue without installing Google Chrome Frame.

**Note**

From WAAS Version 5.4.1, you are no longer prompted to install the Google Frame plug-in when you access the Central Manager GUI using Internet Explorer. However, if the Google Frame plug-in has already been installed, IE will continue to use it.

**Note**

In IE 8 and 9, bookmarks to Central Manager pages other than the home page also go to the home page. In IE 10 and 11, bookmarks work as expected.

**Note**

A known issue in Chrome Version 44.0 may prevent some WAAS CM pages—including Software Updates, Device Listings, and Reports—from loading properly. In Chrome Version 43.0 all WAAS CM pages work as expected.

You can configure the WAAS Central Manager GUI to limit the number of concurrent sessions permitted for a user. The number of concurrent sessions is unlimited by default. To change the number of permitted concurrent sessions, set the `System.security.maxSimultaneousLogins` property, as described in [Modifying the Default System Configuration Properties](#) in Chapter 10, “Configuring Other System Settings.”

**Note**

A user must log out of the Central Manager to end a session. If a user closes the browser or connection without logging off, the session is not closed until after it times out (in 10 minutes by default, up to a possible maximum of 1440 minutes). If the number of concurrent sessions permitted also is exceeded for that user, there is no way for that user to regain access to the Central Manager GUI until after the timeout expires.

**Note**

After an upgrade, downgrade, or new installation, you must first clear the cache in your browser, close the browser, and restart the browser session to the WAAS Central Manager.

Components of the WAAS Central Manager GUI

[Figure 1-2](#) shows the main components of the WAAS Central Manager GUI.

Figure 1-2 Components of the WAAS Central Manager GUI

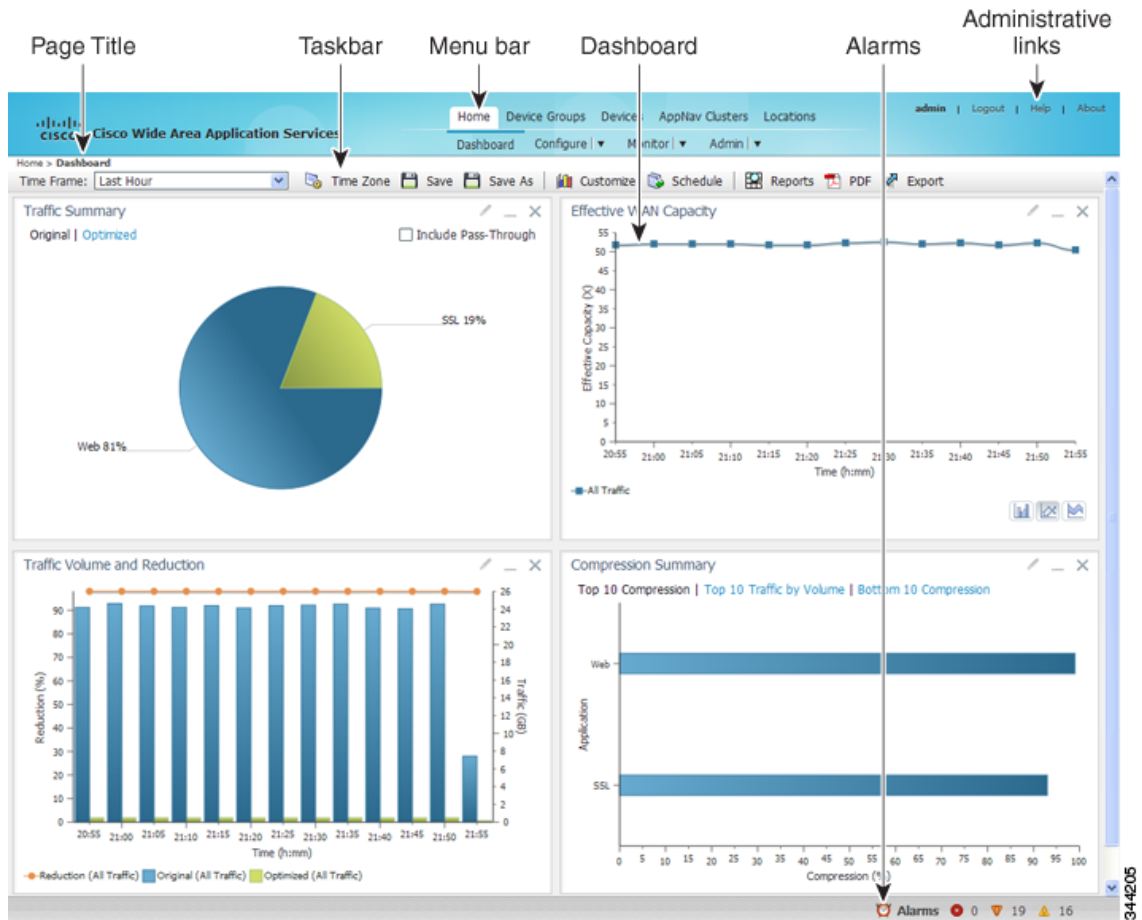

The WAAS Central Manager GUI includes the following main components:

- Page title—Displays the title of the page being viewed and breadcrumb links to ease navigation back to previous levels in the hierarchy. (Breadcrumb links are shown in [Figure 1-3](#).)
- Menu bar—The upper level of the menu bar contains menu options that allow you to choose the context. The lower level of the menu bar contains menu options that group the WAAS Central Manager functions available within the chosen context. For more information, see [WAAS Central Manager Menus](#).
- Taskbar—Contains labeled icons that perform various functions depending on the content shown in the dashboard. For more information, see [WAAS Central Manager Taskbar Icons](#).
- Dashboard—Displays the main content, which changes depending on the option that is chosen in the menu.
- Administrative links—Includes these navigation links:
 - Logout—Logs out the current user from the WAAS Central Manager.
 - Help—Opens a separate window displaying WAAS context-sensitive help.
 - About—Displays the WAAS About window that shows the Central Manager version number.
- Alarms—Opens the alarm panel, which displays alarms in your WAAS network.

The upper level of the menu bar allows you to choose one of the five contexts available in the WAAS Central Manager GUI:

- Home—Click this to go to the global context, with no particular device group, device, AppNav Cluster, or location chosen.
- Device Groups—Choose a device group from this menu option to enter the device group context. The page title and the first menu on the lower level display the name of the chosen device group.
- Devices—Choose a device from this menu option to enter the device context. The page title and the first menu on the lower level display the name of the chosen device, as shown in [Figure 1-3](#).
- AppNav Clusters—Choose an AppNav Cluster from this menu option to enter the AppNav Cluster context. The page title and the first menu on the lower level display the name of the chosen AppNav Cluster.
- Locations—Choose a location from this menu option to enter the location context. The page title and the first menu on the lower level display the name of the chosen location.

Figure 1-3 WAAS Central Manager Device Context

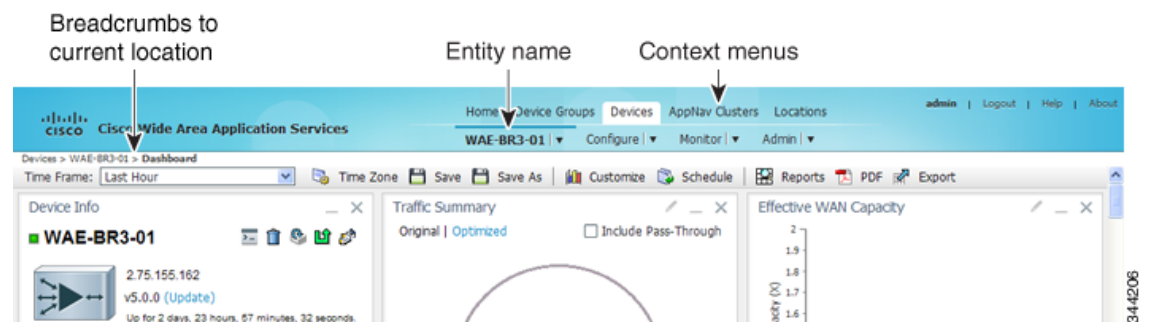

The WAAS Central Manager GUI includes the following items to help you navigate:

- Breadcrumbs to current location—Displays the path to your current location in the menu structure. You can click the **Devices** link to return to the All Devices page.

If you are in the device group context, this link is named **Device Groups** and it returns you to the All Device Groups page. If you are in the AppNav Cluster context, this link is named AppNav Clusters and it returns you to the All AppNav Clusters page.

If you are in the location context, this link is named **Locations** and it returns you to the All Locations page.

- Entity name—The first menu option in the lower level of the menu bar shows the name of the chosen device group, device, AppNav Cluster, or location.
- Context menu options—The top level of the menu bar contains menu options that allow you to switch easily to any entity in any context. You can search for an item by entering a part of its name in the search box at the top and clicking the magnifying glass icon or by pressing **Enter**. The list is filtered to include only entities that contain the search string. The top entry in each menu is All Entities, which takes you to a window that lists all the entities of the selected type, has more advanced search functions, and has taskbar icons that perform functions that are appropriate to the entity group. You can also click the context menu name to go to the corresponding listing window.

In the Devices and AppNav Clusters menu bar options, a small target icon appears when you hover your mouse over a device or cluster name. Place your cursor over the target icon to open a dialog box that shows the device or cluster status (see [Figure 1-4](#)).

Figure 1-4 Devices Context Menu

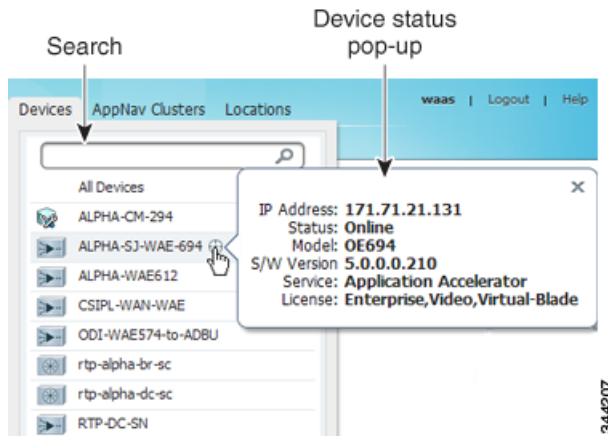

WAAS Central Manager Menus

The WAAS Central Manager menu bar contains two levels of menus:

- Upper level—Contains menu options that allow you to switch to any entity in any context.
- Lower level—Contains menu options that group the WAAS Central Manager functions available within the chosen context. [Table 1-2](#) describes the menu options in the lower menu bar.

Menus contain different functions when a particular device, device group, AppNav cluster, or location is selected than when you are in the global context.

Some menu options contain submenus. Hover the mouse over the triangle to the right of the menu option name to open the submenu.



Note

The functions available for WAAS Express devices are a subset of those available for other WAAS devices. However, some functions are not available on WAAS Express devices.

Table 1-2 Menu Descriptions

Menu	Description
Dashboard or <i>Device, Device group, AppNav Cluster, or Location name</i>	In the global context, allows you to go to the dashboard pertaining to your WAAS network. In a context other than global, this menu is named with the corresponding entity name and allows you to activate devices, view users, assign groups or devices, or view the dashboard or home screen of the entity.
Configure	Allows you to configure WAAS services and settings.
Monitor	Allows you to see network traffic and other charts and reports to monitor the health and performance of your WAAS network. Allows you to manage and schedule reports for your WAAS network. Contains troubleshooting tools.
Admin	Allows you to manage user accounts, passwords, secure store, licenses, update the WAAS software, and view system logs and messages.

WAAS Central Manager Taskbar Icons

Table 1-3 describes the taskbar icons in the WAAS Central Manager GUI.

Table 1-3 Taskbar Icon Descriptions

















Taskbar Icon	Function
Common icons	
 (Refresh)	Refreshes the current page of the WAAS Central Manager GUI.
 (Delete)	Deletes a WAAS element, such as a device or device group.
 (Create or Add)	Creates a new WAAS element, such as a report.
 (Edit)	Edits a WAAS element, such as interface settings.
 (Advanced Search)	Filters the information in a table to make it easier to locate a specific item.
 (View All)	Displays all the items in a table on a single page instead of displaying them over multiple pages.
 (Print or Print Table)	Prints the information.
 (PDF)	Creates a PDF of the information.
 (Assign All)	Selects all the valid items in a table. For example, if you are distributing print drivers to a WAAS print server, you can click this icon to select all the drivers in the list that the print server should download.
 (Remove All)	Deselects all the selected items in a table.
Devices and Device Group Icons	
 (Activate All Inactive Devices)	Activates all the inactive WAAS and WAAS Express devices in your WAAS network.

Table 1-3 Taskbar Icon Descriptions

Taskbar Icon	Function
 (Force Update, Request FullUpdate)	<p>Reapplies the device configuration as seen in the WAAS Central Manager GUI to the device. Normally, changes made in the WAAS Central Manager GUI are applied to the device as soon as the configuration is submitted. From time to time, however, a CLI error or some other error on the device may cause the configuration on the device to differ from what is seen in the WAAS Central Manager GUI. The Force Full Database Update icon applies the full configuration that the WAAS Central Manager has for the device to be updated, to the device, and the configuration is reapplied.</p> <p>When using the Request FullUpdate icon from the device group window, the full device configuration is reapplied to each device in the device group. Group settings do not overwrite device-specific settings.</p> <p>You can view device CLI errors in the System Message window described in Viewing the System Message Log in Chapter 16, “Troubleshooting Your WAAS Network.”</p> <p>The Force Full Database Update icon appears on the Device Dashboard window, described in Device Dashboard Window in Chapter 15, “Monitoring Your WAAS Network.” The Request FullUpdate icon appears in the Modifying Device Group window.</p> <p> Note These functions do not apply to WAAS Express devices.</p>
 (Reload)	Reboots a WAE or device group depending on the location in the WAAS Central Manager GUI. Reload is not available for WAAS Express devices.
 (Force Group Settings)	Forces the device group configuration across all the devices in that group. For more information, see Forcing Device Group Settings on All Devices in the Group in Chapter 3, “Using Device Groups and Device Locations.”
 (Apply Defaults)	Applies the default settings to the fields in the window.
 (Export Table)	Exports table information into a CSV file.
 (Override Group Settings)	Allows you to specify device-specific settings that override the group settings for the device. For more information, see Overriding the Device Group Settings on a Device in Chapter 3, “Using Device Groups and Device Locations.”
 (Deactivate Device)	Deactivates a WAAS or WAAS Express device.
 (Update Application Statistics)	Updates the application statistics.
 (Delete All)	Deletes all the WAAS elements of a particular type, such as IP ACL conditions.
 (Display All Devices)	Displays all WAE devices or device groups.

Table 1-3 Taskbar Icon Descriptions

Taskbar Icon	Function
 (Configure Dashboard Display)	Allows you choose which charts to display in the Device Dashboard window.
 (Copy Settings)	Copies interception settings to other devices (not available for inline interception).
Acceleration Icons	
 (Restore Default Policies and Classifiers)	Restores the default predefined optimization policy rules on the device or device group. For more information, see Restoring Optimization Policies and Class Maps in Chapter 12, “Configuring Application Acceleration.”
 (View Topology)	Displays the topology map that shows all the TFO connections among your WAE devices. For more information, see the Topology Report in Chapter 15, “Monitoring Your WAAS Network.”
 (Navigate to Application Configuration Page)	Displays the configuration page used to create applications. For more information, see Viewing a List of Applications in Chapter 12, “Configuring Application Acceleration.”
System Message Log Icons	
 (Truncate Table)	Allows you to truncate the system message log based on size, date, or message content. For more information, see Viewing the System Message Log in Chapter 16, “Troubleshooting Your WAAS Network.”

WAAS Central Manager Monitoring API

The WAAS Central Manager monitoring application programming interface (API), provides a programmable interface for system developers to integrate with customized or third-party monitoring and management applications. The Central Manager monitoring API communicates with the WAAS Central Manager to retrieve status information and monitoring statistics.

The Central Manager monitoring API is a Web Service implementation. Web Service is defined by the W3C standard as a software system designed to support interoperable machine-to-machine (client and server) interaction over the network. The client and server communication follows the Simple Object Access Protocol or Service Oriented Architecture Protocol (SOAP) standard.

WAAS CLI

The WAAS CLI allows you to configure, manage, and monitor WAEs on a per-device basis through a console connection or a terminal emulation program. The WAAS CLI also allows you to configure certain features that are supported only through the CLI (for example, configuring the Lightweight Directory Access Protocol [LDAP] signing on a WAE). We strongly recommend that you use the WAAS Central Manager GUI instead of the WAAS CLI, whenever possible.

**Note**

You must wait for approximately 10 minutes (two data feed poll cycles) after registering a WAE with the WAAS Central Manager before making any CLI configuration changes on the WAE. Any CLI configuration changes made sooner may be overwritten when the Central Manager updates the WAE. We strongly recommend making all configuration changes by using the Central Manager GUI.

The WAAS CLI is organized into four command modes. Each command mode has its own set of commands to use for the configuration, maintenance, and monitoring of a WAE. The commands that are available to you depend on the mode you are in. When you enter a question mark (?) at the system prompt, you can obtain a list of commands available for each command mode.

The four WAAS command modes are as follows:

- EXEC mode—For setting, viewing, and testing system operations. This mode is divided into two access levels: user and privileged. To use the privileged access level, enter the **enable** command at the user access level prompt, then enter the privileged EXEC password when you see the password prompt.
- Global configuration mode—For setting, viewing, and testing the configuration of WAAS software features for the entire device. To use this mode, enter the **configure** command from the privileged EXEC mode.
- Interface configuration mode—For setting, viewing, and testing the configuration of a specific interface. To use this mode, enter the **interface** command from the global configuration mode.
- Feature-specific configuration mode—Some configuration modes are available from the global configuration mode for managing specific features.

For information about using the CLI to configure a WAAS device, see the [Cisco Wide Area Application Services Command Reference](#) and the [Cisco Wide Area Application Services Quick Configuration Guide](#).

Benefits of Cisco WAAS

This section describes the benefits of Cisco WAAS and includes the following topics:

- [Preservation of Source TCP/IP Information](#)
- [Autodiscovery of WAAS Devices](#)
- [Centralized Network Monitoring and Management](#)
- [Optimized Read and Write Caching](#)
- [WCCP Support](#)
- [PBR Support](#)
- [Inline Interception Support](#)
- [Failure Resiliency and Protection](#)
- [RAID Compatibility](#)
- [Streamlined Security](#)
- [SNMP Support](#)
- [IPv6 Support](#)

Preservation of Source TCP/IP Information

Many optimization products create tunnels through routers and other networking devices, which result in a loss of source TCP/IP information in the optimized data. This loss of TCP/IP information often disrupts important network services (such as QoS and NBAR), and can disrupt proper operation of traffic analysis tools such as NetFlow and security products and features such as ACLs and IP-based firewalls.

Unlike other optimization products, Cisco WAAS seamlessly integrates into your network and preserves all TCP/IP header information in the traffic that it optimizes, so that your existing analysis tools and security products are not compromised.

Autodiscovery of WAAS Devices

Cisco WAAS includes an autodiscovery feature that enables WAEs to automatically locate peer WAEs on your network. After autodiscovering a peer device, the WAEs can terminate and separate the LAN-to-WAN TCP connections and add a buffering layer to resolve the differing speeds. Once a WAE establishes a connection to a peer WAE, the two devices can establish an optimized link for TCP traffic, or pass the traffic through as unoptimized.

The autodiscovery of peer WAAS devices is achieved using proprietary TCP options. These TCP options are only recognized and understood by WAAS devices and are ignored by non-WAAS devices.

Centralized Network Monitoring and Management

Cisco WAAS Web-based management tools (WAAS Central Manager GUI) enable IT administrators to centrally define, monitor, and manage policies for each WAAS device, such as usage quota, backups, disaster recovery, restores, access control, and security policies. IT administrators can also perform the following tasks:

- Remotely provision, configure, and monitor each WAAS device or device group.
- Optimize system performance and utilization with comprehensive statistics, logs, and reporting.
- Perform troubleshooting tasks using tools such as SNMP-based monitoring, traps and alerts, and debug modes.

IT administrators benefit from the following features of Cisco WAAS:

- Native protocol support—Provides complete end-to-end support for the underlying file system protocol (Windows) used by the enterprise. Security, concurrency, and coherency are preserved between each client and file server.
- Transparency—Is fully transparent to applications, file systems, and protocols, enabling seamless integration with existing network infrastructures, including mixed environments. Cisco WAAS also has no impact on any security technology currently deployed.
- Branch office data protection—Increases data protection at branch offices. Its file cache appears on the office's LAN in the same way as a local file server. End users can map their personal document folders onto the file cache using Windows or UNIX utilities. A cached copy of user data is stored locally in the branch WAE for fast access. The master copy is stored centrally in the well-protected data center.
- Centralized backup—Consolidates data across the extended enterprise into a data center, which makes it easy to apply centralized storage management procedures to branch office data. Backup and restore operations become simpler, faster, and more reliable than when the data was decentralized.

In the event of data loss, backup files exist in the data center and can be quickly accessed for recovery purposes. The amount of data loss is reduced because of the increased frequency of backups performed on the centralized storage in the data center. This centralized storage backup makes disaster recovery much more efficient and economical than working with standalone file servers or NAS appliances.

- Simplified storage management—Migrates storage from remote locations to a central data facility, which reduces costs and simplifies storage management for the extended enterprise.
- WAN adaptation—Provides remote users with near-LAN access to files located at the data center. WAAS uses a proprietary protocol that optimizes the way traffic is forwarded between the WAEs.

Optimized Read and Write Caching

The common file services feature in Cisco WAAS maintains files locally, close to the clients. Changes made to files are immediately stored in the local branch WAE, and then streamed to the central file server. Files stored centrally appear as local files to branch users, which improves access performance. SMB caching includes the following features:

- Local metadata handling and caching—Allows metadata such as file attributes and directory information to be cached and served locally, optimizing user access.
- Partial file caching—Propagates only the segments of the file that have been updated on write requests rather than the entire file.
- Write-back caching—Facilitates efficient write operations by allowing the data center WAE to buffer writes from the branch WAE and to stream updates asynchronously to the file server without risking data integrity.
- Advance file read—Increases performance by allowing a WAE to read the file in advance of user requests when an application is conducting a sequential file read.
- Negative caching—Allows a WAE to store information about missing files to reduce round-trips across the WAN.
- Microsoft Remote Procedure Call (MSRPC) optimization—Uses local request and response caching to reduce the round-trips across the WAN.
- Signaling messages prediction and reduction—Uses algorithms that reduce round-trips over the WAN without loss of semantics.

WCCP Support

The Web Cache Communication Protocol (WCCP) developed by Cisco Systems specifies interactions between one or more routers (or Layer 3 switches) and one or more application appliances, web caches, and caches of other application protocols. The purpose of the interaction is to establish and maintain the transparent redirection of selected types of traffic flowing through a group of routers. The selected traffic is redirected to a group of appliances. Any type of TCP traffic can be redirected.

The WCCP v2 protocol has a built-in set of beneficial features, for example, automatic failover and load balancing. The router monitors the liveness of each WAE attached to it through the WCCP keepalive messages, and if a WAE goes down, the router stops redirecting packets to the WAE. By using WCCP, the branch WAE avoids becoming a single point of failure. The router can also load balance the traffic among a number of branch WAEs.

Cisco WAAS supports transparent interception of TCP sessions through WCCP. Once WCCP is turned on at both the router and the branch WAE, only new sessions are intercepted. Existing sessions are not affected.

PBR Support

Policy-based routing (PBR) allows IT organizations to configure their network devices (a router or a Layer 4 to Layer 6 switch) to selectively route traffic to the next hop based on the classification of the traffic. WAAS administrators can use PBR to transparently integrate a WAE into their existing branch office network and data centers. PBR can be used to establish a route that goes through a WAE for some or all packets based on the defined policies.

For more information about PBR, see [Chapter 5, “Configuring Traffic Interception.”](#)

Inline Interception Support

Direct inline traffic interception is supported on WAEs with a Cisco WAE Inline Network Adapter or Interface Module installed. Inline interception of traffic simplifies deployment and avoids the complexity of configuring WCCP or PBR on the routers.

An inline WAE transparently intercepts traffic flowing through it or bridges traffic that does not need to be optimized. It also uses a mechanical fail-safe design that automatically bridges traffic if a power, hardware, or unrecoverable software failure occurs.



Note

AppNav Controller Interface Modules do not support automatic bypass mode to continue traffic flow in the event of a failure. For high availability, two or more AppNav Controller Interface Modules should be deployed in an AppNav cluster. For more information on using inline mode with the AppNav solution, see [Chapter 4, “Configuring AppNav.”](#)

You can configure the inline WAE to accept traffic only from certain VLANs; for all other VLANs, traffic is bridged and not processed.

You can serially cluster inline WAE devices to provide higher availability in the event of a device failure. If the current optimizing device fails, the second inline WAE device in the cluster provides the optimization services. Deploying WAE devices in a serial inline cluster for the purposes of scaling or load balancing is not supported.

For more information about inline mode, see the [Using Inline Mode Interception](#) in Chapter 5, “Configuring Traffic Interception.”

Failure Resiliency and Protection

Cisco WAAS provides a high-availability failover (and load-balancing) function that minimizes the probability and duration of SMB downtime.

If a WAE configured for SMB fails, all peer WAEs configured to operate with it are redirected to work with an alternate WAE. This operation maintains high availability without service interruption.

This change may not be transparent to users, which means that client connections are closed and require SMB clients to reestablish their connection. Whether such changes impact currently running applications depends on the behavior of the application being used, and on the behavior of the specific SMB client. Typically, however, the transition is transparent to the client.

RAID Compatibility

Cisco WAAS provides the following Redundant Array of Independent Disks (RAID) capability for increased storage capacity or increased reliability:

- Logical Disk Handling with RAID-5—Logical disk handling with Redundant Array of Independent Disks-5 (RAID-5) is implemented in WAAS as a hardware feature. RAID-5 devices can create a single logical disk drive that may contain up to six physical hard disk drives, providing increased logical disk capacity.

Systems with RAID-5 can continue operating if one of the physical drives fails or goes offline.

**Note**

RAID Controller Firmware 12.12.0(0060) or later version is required for Toshiba SSD to work on WAVE 8541 model. Else it is unable to create a RAID.

- Logical Disk Handling with RAID-1—Logical disk handling with RAID-1 is implemented in WAAS as a software feature. RAID-1 uses disk mirroring to write data redundantly to two or more drives, providing increased reliability.

Because the software must perform each disk write operation against two disk drives, the filesystem write performance may be affected.

- Disk Hot-Swap Support—WAAS for RAID-1 allows you to hot-swap the disk hardware. RAID-5 also allows you to hot-swap the disk hardware after the RAID array is shut down. For the disk removal and replacement procedures for RAID systems, see [Chapter 14, “Maintaining Your WAAS System.”](#)

Streamlined Security

Cisco WAAS supports disk encryption, which addresses the need to securely protect sensitive information that flows through deployed WAAS systems and that is stored in WAAS persistent storage.

Cisco WAAS does not introduce any additional maintenance overhead on already overburdened IT staffs. Cisco WAAS avoids adding its own proprietary user management layer, and instead makes use of the users, user credentials, and access control lists maintained by the file servers. All security-related protocol commands are delegated directly to the source file servers and the source domain controllers. Any user recognized on the domain and source file server are automatically recognized by Cisco WAAS with the same security level, and all without additional configuration or management.

Cisco WAAS delegates access control and authentication decisions to the origin file server.

SNMP Support

Cisco WAAS supports Simple Network Management Protocol (SNMP) including SNMPv1, SNMPv2, and SNMPv3. Cisco WAAS supports many of the most commonly used SNMP managers, such as HP OpenView and IBM Tivoli NetView.

Most Cisco WAAS traps are also recorded in the logs displayed in the WAAS Central Manager GUI, although some (such as exceeding the maximum number of sessions) are reported only to the SNMP manager.

Cisco WAAS supports parameters based on SNMPv2, enabling it to integrate into a common SNMP management system. These parameters enable system administrators to monitor the current state of the WAAS network and its level of performance.

Exported parameters are divided into the following categories:

- General parameters—Includes the version and build numbers and license information.
- Management parameters—Includes the location of the Central Manager.
- Data center WAE parameters—Includes the general parameters, network connectivity parameters, and file servers being exported.
- Branch WAE parameters—Includes the general parameters, network connectivity parameters, and cache statistics.

For more information about SNMP and supported MIBs, see [Chapter 17, “Configuring SNMP Monitoring.”](#)

IPv6 Support

Release 6.0 onwards, IPv6 support is implemented for management access to WAAS devices. Basic IPv6 connectivity can be enabled on the WAAS interfaces by assigning IPv6 addresses, configuring default gateway and static IP routes. This can be further enhanced by configuring support for AAAA record types in the Domain Name System (DNS) name-to-address and address-to-name lookup processes and by managing IPv6 neighbour discovery

All devices in the WAAS network can communicate in the IPv6 network using Telnet, SSH, FTP, TFTP, in IPv6 addresses. The management plane can configure IPv6 address for syslog, AAA servers, ntp servers, snmp servers and name servers to communicate with WAAS devices.



Planning Your WAAS Network

This chapter describes general guidelines, restrictions, and limitations that you should be aware of before you set up your Cisco Wide Area Application Services (WAAS) network.



Note

Throughout this chapter, the term WAAS device is used to refer collectively to the WAAS Central Managers and Cisco Wide Area Application Engines (WAEs) in your network. The term WAE refers to WAE and Cisco Wide Area Virtual Engine (WAVE) appliances, Cisco Services Ready Engine (SRE) Service Modules (SMs) running WAAS, and Cisco Virtual WAAS instances.

This chapter contains the following sections:

- [Checklist for Planning Your WAAS Network](#)
- [Site and Network Planning](#)
- [Overview of Autoregistration and WAEs](#)
- [Interoperability and Support](#)
- [WAAS Devices and Device Mode](#)
- [Calculating the Number of WAAS Devices Required](#)
- [Supported Methods of Traffic Redirection](#)
- [Access Lists on Routers and WAEs](#)
- [WAAS Login Authentication and Authorization](#)
- [Logically Grouping Your WAEs](#)
- [Data Migration Process](#)

Checklist for Planning Your WAAS Network

Cisco Wide Area Application Engines (WAEs) that are running the Cisco WAAS software can be used by enterprises or service providers to optimize the application traffic flows between their branch offices and data centers. You should deploy WAE nodes at the WAN endpoints near the networked application clients and their servers, where they intercept WAN-bounded application traffic and optimize it. You must insert WAE nodes into the network flow at defined processing points.

WAAS software supports the following three typical network topologies:

- Hub and spoke deployments—In a hub and spoke deployment, servers are centralized, and branch offices host clients and a few local services only, for example, WAAS printing services.

- Mesh deployments—In a mesh deployment, a location can host both clients and servers, and the clients can access any number of local or remote servers.
- Hierarchical deployments—In a hierarchical deployment, servers are located in multiple regional and national data centers, and can be accessed by different clients. The connections between the data centers are of higher bandwidth than the connections to the branch offices.

The deployments are characterized according to the WAAS element connections, which follow the client-server access pattern and may differ from the physical network links. For more information, see [Chapter 1, “Introduction to Cisco WAAS.”](#)

Planning Checklist

When you are planning your WAAS network, use the following checklist as a guideline. As the following checklist indicates, you can break the planning phase into the following three main categories of planning activities:

- Sizing phase
- Planning for management
- Planning for application optimization



Note

Although there are some interdependencies, you do not have to complete all of the steps in a particular planning phase before you start the next step.

To plan your network, follow these guidelines:

1. Complete the sizing phase that includes the following tasks:
 - Determine which locations in your existing network require WAAS optimization, for example, branch offices and data centers.
 - Determine if you are going to use a traditional WAAS deployment model or the AppNav deployment model. For more information on AppNav, see [Chapter 4, “Configuring AppNav.”](#)
 - Determine the number and models of the WAAS devices that are required for each location. Some key factors in this selection process is the WAN bandwidth, the number of users, and the expected use. Various hardware configurations are possible, for example, different hard disk models and RAM size. Consider running a cluster of WAEs where additional scalability and or failover is required. For more information, see [Calculating the Number of WAAS Devices Required.](#)
 - Verify that you have purchased sufficient licenses to cover your requirements.
2. Plan for management as follows:
 - Complete site and network planning, for example, obtain the IP and routing information, including IP addresses and subnets, routers and default gateway IP addresses, and hostnames for devices. See the “Checklist of WAAS Network System Parameters” table in the *Cisco Wide Area Application Services Quick Configuration Guide*.
 - Determine the login authentication and login authorization methods, for example, external RADIUS, TACACS+, Windows domain servers, and accounting policies that you want your WAAS Central Managers and WAEs to use. For more information, see [Chapter 7, “Configuring Administrative Login Authentication, Authorization, and Accounting.”](#)

- For security purposes, plan to change the predefined password for the predefined superuser account immediately after you have completed the initial configuration of a WAE. For more information, see [WAAS Login Authentication and Authorization](#).
 - Determine if you need to create any additional administrative accounts for a WAAS device. For more information, see [Chapter 8, “Creating and Managing Administrator User Accounts and Groups.”](#)
 - Determine if you should group your WAEs into logical groups. For more information, see [Logically Grouping Your WAEs](#).
 - Determine which management access method to use. By default, Telnet is used, but SSH may be the preferred method in certain deployments. For more information, see [Configuring Login Access Control Settings for WAAS Devices](#) in Chapter 7, “Configuring Administrative Login Authentication, Authorization, and Accounting.”
3. Plan for application optimization as follows:
- Determine and resolve router interoperability issues, for example, the supported hardware and software versions, router performance with interception enabled. For more information, see [Site and Network Planning](#).
 - Determine the appropriate interception location when the data center or branch office is complex, for example, if your existing network uses a hierarchical topology.
 - Determine which WAAS services to deploy. For more information about the different WAAS services, see [Chapter 1, “Introduction to Cisco WAAS.”](#)
 - Determine which WAAS software licenses to install. Software licenses enable specific WAAS services. For more information about installing software licenses, see the [Managing Software Licenses](#) in Chapter 10, “Configuring Other System Settings.”
 - Determine which traffic interception methods to use in your WAAS network, for example, AppNav, inline mode, WCCP Version 2, or policy-based routing (PBR).
 - For more information on the advantages and disadvantages of using WCCP, see [Supported Methods of Traffic Redirection](#).
 - For more information on WCCP traffic interception and redirection, see [Overview of Traffic Interception Methods](#) in Chapter 5, “Configuring Traffic Interception.”



Note WCCP works only with IPv4 networks.

- If you plan to use the WCCP TCP promiscuous mode service as a traffic interception method, determine whether you should use IP access control lists (ACLs) on your routers.



Note IP ACLs that are defined on a router take precedence over the ACLs that are defined on the WAE. For more information, see [Access Lists on Routers and WAEs](#).

- Determine whether you have to define IP ACLs or interception ACLs on the WAEs. For more information, see [Access Lists on Routers and WAEs](#).



Note ACLs that are defined on a WAE take precedence over the WAAS application definition policies that are defined on the WAE.

- If PBR is to be used, determine which PBR method to use to verify PBR next-hop availability for your WAEs. For more information, see [Methods of Verifying PBR Next-Hop Availability](#) in Chapter 5, “Configuring Traffic Interception.”
- Determine the major applications for your WAAS network. Verify whether the predefined application definition policies cover these applications and whether you should add policies if your applications are not covered by these predefined policies. For a list of the predefined application definition policies, see [Appendix A, “Predefined Optimization Policy.”](#)
- Consider day zero migration of file systems if file servers are to be centralized in the process. For more information, see [Data Migration Process](#).

After you complete the planning tasks, you are ready to perform a basic configuration of a WAAS network, as described in the *Cisco Wide Area Application Services Quick Configuration Guide*.

Site and Network Planning

Before you install and deploy WAAS devices in your network, collect information about your network to accommodate the integration of the WAAS devices.

In a typical distributed organizational layout, there are two types of networks where WAAS devices are installed:

- The data center (central office), where one or more colocated data center WAEs provide access to the resident file and application servers. In data centers, you can deploy a WAE as a single device or a pair of WAEs as a high-availability or load-sharing pair. High availability pairs are supported if either WCCP Version 2 or PBR is being used for traffic redirection to the data center; load-sharing pairs are supported only if WCCP Version 2 is being used for traffic redirection to the data center.
- The branch offices, where branch WAEs enable users to access the file and application servers over the WAN. In branch offices, you can deploy a WAE as a single device or a pair of WAEs as a high-availability or load-sharing pairs. High-availability pairs are supported if either WCCP Version 2 or PBR is being used for traffic redirection in the branch office; load-sharing pairs are only supported if WCCP Version 2 is being used for traffic redirection in the branch office.

In collaborative networks, colocated data center WAEs and branch WAEs are deployed throughout the network. These colocated WAEs are configured to share data in opposite directions (two cross-linked servers).

The WAE attaches to the LAN as an appliance. A WAE relies on packet interception and redirection to enable application acceleration and WAN optimization. Consequently, traffic interception and redirection to a WAE must occur at each site where a WAE is deployed. Traffic interception and redirection occurs in both directions of the packet flow. Because Layer 3 and Layer 4 headers are preserved, you should ensure that you always connect a WAE to a tertiary interface (or a subinterface) on the router to avoid routing loops between the WAE and the WCCP or PBR-enabled router that is redirecting traffic to it. For more information on this topic, see [Using Tertiary Interfaces or Subinterfaces to Connect WAEs to Routers](#).



Note

We strongly recommend that you do not use half-duplex connections on the WAE or on routers, switches, or other devices because half duplex impedes performance. Check each Cisco WAE interface and port configuration on the adjacent device (router, switch, firewall, or WAE) to verify that full duplex is configured.

**Note**

The data center WAE and branch WAE communicate with each other only if the firewall is open.

This section contains the following topics:

- [Windows Network Integration](#)
- [UNIX Network Integration](#)
- [SMB-Related Ports in a WAAS Environment](#)
- [Firewalls and Standby Central Managers](#)
- [Performance Tuning for High WAN Bandwidth Branch Offices](#)

Windows Network Integration

To successfully integrate WAAS devices into the Windows environment, you might have to perform certain tasks on both the data center WAE and branch WAE sides of the network. This section contains the following topics:

- [Data Center WAE Integration](#)
- [Branch WAE Integration](#)

Data Center WAE Integration

Before the initial configuration of the data center WAE, you should know the following parameters:

- WINS server (if applicable).
- DNS server and DNS domain (if applicable).
- A browsing user with file-server directory traversal (read-only) privileges. This user, who is usually set up as a domain or service user, is required for running preposition policies.

To successfully integrate Cisco WAAS into the Windows environment on the data center WAE side of a network where DHCP is not being used, you must manually add the name and IP address of the data center WAE to the DNS server. You should take this action before installing and deploying the WAAS devices.

**Note**

User permissions are determined by the existing security infrastructure.

Branch WAE Integration

Before the initial configuration of the branch WAE, you should know the following parameters:

- DNS server and DNS domain
- Windows Domain Name
- WINS server (if applicable)

To successfully integrate Cisco WAAS into the Windows environment on the branch WAE side of the network, you should take the following preliminary actions before installing and deploying the WAAS devices in your network:

- To enable all branch WAEs in the specified domain to appear in the Network Neighborhood of users within the same domain, ensure that a Domain Master Browser or local Master Browser is active.
- If DHCP is not used, you must manually add the name and IP address of the branch WAE to the DNS server.

UNIX Network Integration

Before the initial configuration of a WAAS device, you should know the following parameters:

- DNS server and DNS domain.
- NIS server parameters (if applicable).
- On the data center WAE side, a browsing UID or GID with file-server directory traversal (read-only) privileges. This UID or GID, which is usually set up as a domain or service user, is required for browsing when defining coherency policies.

To successfully integrate Cisco WAAS into the UNIX environment, you should perform these actions on both the data center WAE and branch WAE sides of the network:

- Manually add the name and IP address of both the data center WAE and the branch WAE to the DNS server.
- When separate domains are used, UNIX users may be defined at the remote (branch) offices or on the central servers. This situation may result in the same user name being defined in different domains. A user may be defined differently in the branch and center or may be defined only on one end and not on the other. You can ensure consistency in such cases by using NIS or by mapping between the different domains, either manually or automatically. That is, users can be mapped from the remote server to the central servers by translating their identities from the central office to the remote offices.



Note

To map users using automatic management, you must first configure the NIS server in both the data center WAE (primary) and branch WAE (secondary).

SMB-Related Ports in a WAAS Environment

This section describes the SMB-related ports used between your clients, WAEs that are accelerating SMB traffic, and SMB file servers. Most SMB communication occurs between the branches and the central office. This communication is encrypted and delivered through the organization's VPN. No ports on the firewall have to be opened because all communication is tunneled internally.

You only have to change the firewall setup if administrative or other maintenance work has to be done from a location outside the organization.

Ports 139 and 445

If you have deployed SMB acceleration services in your WAAS network, your WAAS network uses ports 139 and 445 to connect clients to a branch WAE and to connect a data center WAE to the associated file servers. The port that is used depends on the configuration of your WAAS network.

If WCCP is enabled or inline mode is used, the branch WAE accepts client connections on ports 139 or 445. If WCCP nor inline mode is enabled, the branch WAE accepts connections only over port 139.

Your WAAS network always tries to use the same port to communicate end-to-end. Consequently, if a client uses port 445 to connect to a branch WAE, the associated data center WAE will try to use the same port to connect to the file server. If port 445 is unavailable, the data center WAE will try to use port 139.

**Note**

The CIFS application accelerator is removed from WAAS Version 6.0 and later, but the CIFS policy is continued for two ports: port 139 and port 445. For these ports only, the SMB application accelerator runs on CIFS policy. Therefore, an alarm generated by SMB on port 139 or port 445 is seen as a CIFS alarm.

Some organizations close port 139 on their networks to minimize the security risks associated with this port. If your organization has closed port 139 for security reasons, you can configure your WAAS network to bypass port 139. If this is the case in your organization, you should perform the following task to bypass port 139 and use port 445 in its place if you use the SMB application accelerator, running on CIFS policy, for these ports:

- Enable WCCP Version 2 on your routers and branch WAE, as described in the *Cisco Wide Area Application Services Quick Configuration Guide*. Alternatively, you can use inline mode on a branch WAE with a Cisco WAE Inline Network Adapter or Cisco Interface Module installed.

Ports 88 and 464

If you are using Windows Domain authentication with Kerberos enabled, the WAE uses ports 88 and 464 to authenticate clients with the domain controller.

Firewalls and Standby Central Managers

Primary and standby Central Managers communicate on port 8443. If your network includes a firewall between primary and standby Central Managers, you must configure the firewall to allow traffic on port 8443 so that the Central Managers can communicate and stay synchronized.

Performance Tuning for High WAN Bandwidth Branch Offices

WAAS combines Layer 4 TCP optimizations with Layer 7 application accelerators for various protocols. For some branch offices with high WAN bandwidth, for example, above 50 Mbps, if the native latency is low, for example, below 20 ms RTT, depending on the number of user sessions and data patterns, applying Layer 4 optimizations alone may provide optimal levels of performance. In such cases, we recommend that you measure end-user response times under production load to determine the appropriate operational state for the application accelerators and sizing.

Overview of Autoregistration and WAEs

Autoregistration automatically configures primary network settings and registers a WAE with the WAAS Central Manager device. On startup, a WAAS device (except for the WAAS Central Manager itself) that does not have an existing network configuration on its primary interface can automatically discover the WAAS Central Manager device and register with it. You do not have to manually configure the network

settings of the primary interface on the WAAS device. This feature is useful for large-scale automated deployments of devices. After a WAE is registered, configure other interfaces and settings on the device remotely by using the WAAS Central Manager GUI.

In the example configuration provided in the *Cisco Wide Area Application Services Quick Configuration Guide*, the autoregistration feature is disabled on the WAEs when the setup utility is used to perform the initial configuration of the device and manually configure the interface settings.

Autoregistration uses a form of the Dynamic Host Configuration Protocol (DHCP). For autoregistration to function, you must have a DHCP server that is configured with basic settings.

**Note**

The WAE sends CISCOCDN as the vendor-class identifier in option 60 of the DHCP DISCOVER message to facilitate your grouping of WAEs into device groups.

Autoregistration DHCP requires that the following options be present in the DHCP server's offer:

- Subnet mask (option 1)
- Router (default gateway) (option 3)
- Domain name (option 15)
- Domain name servers (option 6)

Additionally, the DHCP offer can contain the WAE hostname (option 12), but it is not required. If the hostname option is not supplied, the WAE hostname is automatically set to NO-HOSTNAME-*a-b-c-d*, where *a.b.c.d* is the IP address that is assigned to the WAE by the DHCP server.

All of the above options, with the exception of domain name servers (option 6), replace the existing configuration on the system. The domain name servers option is added to the existing list of name servers with a restriction of a maximum of eight name servers.

After the WAE configures its network settings from DHCP, it requires the Central Manager hostname so that it can register with the Central Manager. The WAE queries the configured DNS server to obtain the Central Manager hostname. For autoregistration to work, you must configure the DNS server with the Central Manager hostname by configuring a DNS SRV (Service Location) record. This record is easy to configure and does not affect normal DNS operation. The DNS SRV record must be configured as follows:

- Service is `_waascms`
- Protocol is `_tcp`
- Host offering this service is the fully qualified domain name (FQDN) of the Central Manager

To create an SRV record in Windows Server 2008, open the DNS Manager, navigate to Forward Lookup Zones, and select the correct DNS zone. Right click the zone, choose **Other New Records**, and then choose **Service Location (SRV)**.

If the DNS request fails or if the domain is not configured, the WAE tries an alternative DNS query for an SRV record to the `ciscowaas.local` domain. If this alternative request also fails, the WAE cannot register with the Central Manager. However, the network configuration remains and allows you to connect through Telnet to perform additional configuration from the CLI.

Autoregistration is enabled by default on the first interface of the device. On a Cisco NME-WAE module, autoregistration is enabled on the configured interface. On an SRE-SM module, autoregistration is disabled by default.

**Note**

You must disable autoregistration when both device interfaces are configured as port-channel interfaces.

If you do not have a DHCP server, the device is unable to complete autoregistration and eventually times out. You can disable autoregistration at any time after the device has booted, and proceed with manual setup and registration.

To disable autoregistration, or to configure autoregistration on a different interface, use the **no auto-register enable** command in global configuration mode. If you want to preserve the dynamically configured IP address on the interface as a static IP address when you disable autoregistration, use the **preserve-ip** option with this command. This option prevents the WAE from losing network connectivity because its IP address is removed.

**Note**

Autoregistration is automatically disabled if a static IP address is configured or if you configure interface-level DHCP on the same interface that autoregistration uses. (See [Selecting Static IP Addresses or Using Interface-Level DHCP](#).)

The following example shows how to disable autoregistration on the interface GigabitEthernet 1/0:

```
WAE(config)# no auto-register enable GigabitEthernet 1/0 preserve-ip
```

Autoregistration status can be obtained by using the following **show EXEC** command:

```
WAE# show auto-register
```

For WAAS Release 6.0 and above, autoregistration is possible for a dual stack WAAS device. In a dual-stack network, the WAAS device should be able to get a IPv6 DHCP address and an IPv6 Central Manager address through DNS entry or in the DHCP pool and then register with the Central Manager using IPv6. If IPv6 DHCP fails and IPv4 is also configured on the auto-registration interface, then the device should fall back to getting IPv4 address and proceed as it would in a IPv4-only network.

Selecting Static IP Addresses or Using Interface-Level DHCP

During the initial configuration, you have the option of configuring a static IP address for the device or choosing DHCP.

DHCP is a communications protocol that allows network administrators to manage their networks centrally and automate the assignment of IP addresses in an organization's network. When an organization sets up its computer users with a connection to the network, an IP address must be assigned to each device. Without DHCP, the IP address must be entered manually for each computer, and if computers move to another location in another part of the network, the IP address must be changed accordingly. DHCP automatically sends a new IP address when a computer is connected to a different site in the network.

If you have a DHCP server configured, autoregistration automatically configures the network settings and registers WAEs with the WAAS Central Manager device upon bootup.

If you do not have a DHCP server configured, or you have a DHCP server, but do not want to use the autoregistration feature, manually configure the following network settings with the interactive setup utility or CLI, and then register the WAEs with the WAAS Central Manager device. Configure these settings:

- Interface IP address and subnet mask
- IP domain name
- Hostname
- IP name server
- Default gateway

- Primary interface

When a WAAS device boots, you are prompted to run the first-time setup utility (enter basic configuration), which you use to set up the basic device network settings for the WAE.

Interoperability and Support

This section describes WAAS interoperability with and support for how to identify and resolve interoperability issues. It contains the following topics:

- [Unicode Support for WAAS GUI Interfaces](#)
- [WAAS and Cisco IOS Interoperability](#)
- [WAAS AOs Interoperability with Third-Party Load Balancers](#)
- [WAAS Compatibility with Other Cisco Appliances and Software](#)

Unicode Support for WAAS GUI Interfaces

The WAAS software supports Unicode in the WAAS Central Manager and the WAE Device Manager GUI interfaces.

- *In the WAAS Central Manager*, you can create preposition policies that include Unicode characters. For example, you can define a preposition policy for a directory that contains Unicode characters in its name.

Specifically, the root directory and file pattern fields in the preposition policies in the WAAS Central Manager GUI support Unicode.

- *In the WAE Device Manager GUI*, you can include Unicode characters in the name of the backup configuration file. In addition, the logs included in the WAE Device Manager GUI can display Unicode characters.

Note the following about Unicode support limitations:

- Usernames cannot contain Unicode characters.
- When defining policies for coherency, and so on, you cannot use Unicode characters in the Description field.
- File server names cannot contain Unicode characters.

For a list of the hardware, SMB clients, and web browsers supported by the WAAS software, see the [Release Note for Cisco Wide Area Application Services](#).

WAAS and Cisco IOS Interoperability

This section describes the interoperability of the WAAS software with the Cisco IOS features for a basic WAAS deployment that uses WCCP-based interception and transparent transport, and contains the following topics:

- [WAAS and the Cisco IOS QoS Classification Feature](#)
- [WAAS and the Cisco IOS NBAR Feature](#)
- [WAAS and Cisco IOS Marking](#)
- [WAAS and Cisco IOS Queuing](#)

- [WAAS and Cisco IOS Congestion Avoidance](#)
- [WAAS and Cisco IOS Traffic Policing and Rate Limiting](#)
- [WAAS and Cisco IOS Signaling](#)
- [WAAS and Cisco IOS Link-Efficiency Operations](#)
- [WAAS and Cisco IOS Provisioning, Monitoring, and Management](#)
- [WAAS and Management Instrumentation](#)
- [WAAS and MPLS](#)

**Note**

The WAAS software does not support Mobile IP.

We recommend that you use Cisco IOS Software Release 12.2 or later.

WAAS and the Cisco IOS QoS Classification Feature

Classify packets by using a policy filter, for example, using QPM, that is defined on the packets. You can use the following policy filter properties:

- Source IP address or hostname—Supported under WAAS because the source IP address is preserved by the WAAS device.
- Source TCP/UDP port (or port range)—Supported under WAAS because the source port is preserved by the WAAS device.
- Destination IP address or hostname—Supported under WAAS because the destination IP is preserved by WAAS. WAAS relies on interception at the data center for redirecting traffic to the peer WAAS device.
- Destination TCP/UDP port (or port range)—Supported under WAAS because the destination IP is preserved by WAAS. WAAS relies on interception at the data center for redirecting traffic to the peer WAAS device.
- DSCP/IP precedence (TOS)—Supported under WAAS because WAAS copies the settings of incoming packets on to the outgoing packets from WAAS back to the router. If the packets are not colored at connection establishment time (for TCP packets), there might be a delay in propagating the settings because WAAS does not poll these settings periodically. The packets are eventually colored properly. When packets are not colored, they are left uncolored by the WAAS software.

**Note**

WAAS software does not support QoS, MPLS QoS, ATM QoS, Frame Relay QoS, and Layer 2 (VLAN) QoS.

WAAS and the Cisco IOS NBAR Feature

Unlike a traditional type of classification that is specified through a policy filter that is listed in [WAAS and the Cisco IOS QoS Classification Feature](#), Network-Based Application Recognition (NBAR) classification needs to consider payload. The classification keeps track of any interceptor that modifies the payload because this modification might cause NBAR to not be able to classify the packets. However, the WAAS software does support NBAR.

The following is an example flow of how the WAAS software supports NBAR:

1. A packet, P1, which is a part of a TCP stream, S1, enters the router and is classified by NBAR on the LAN interface of the router as belonging to class C1. If the classification of P1 does not involve payload inspection, for example, only TCP/IP headers, no action is to be taken because the WAAS software preserves this information.
2. If P1 classification requires payload inspection, P1 should be marked using the TOS/DSCP bits in the packet (as opposed to using other internal marking mechanisms).
3. P1 is then intercepted through WCCP Version 2 (still on the LAN interface, WCCP is processed after NBAR) and is redirected to a WAE.
4. WAAS applies optimizations, if any, on the payload and copies the DSCP bits settings from the incoming TCP stream, S1, onto the outgoing stream, S2 (which is established between the local WAAS appliance and the remote WAAS appliance over the WAN). Because NBAR usually has to see some payload before performing the classification, it is unlikely that WAAS will have the proper bit settings at connection-establishment time. Consequently, the WAAS software uses polling to inspect the DSCP bits on the incoming TCP stream, and then copies it over to the stream from the WAAS device back to the router.
5. When S2 re-enters the router, NBAR will not classify S2 as belonging to C1 because the payload has been changed or compressed. However, the DSCP settings have already marked these packets as belonging to C1. Consequently, these packets will be treated appropriately as if they were classified through NBAR.

As long as the flow is not identified, NBAR will continue to search for classification in the packets. Because compressed packets will not be classified, this situation can unnecessarily burden the CPU (performing packet inspection). Because of the potential degradation in performance and the slight possibility of correctness issues, we strongly recommend that you use a subinterface or a separate physical interface to connect the WAE to the router (as described in [Using Tertiary Interfaces or Subinterfaces to Connect WAEs to Routers](#)). When you use a tertiary interface or subinterface to connect the WAE to the router, both the performance and correctness issues are addressed because each packet is processed only once.

6. For dynamic classifications, NBAR maintains a per-flow state. After certain flows are classified, NBAR does not continue to perform deep-packet inspection anymore. However, for other flows, for example, Citrix, NBAR does look at packets continuously because the classification may change dynamically in a flow. Therefore, in order to support all NBAR classifications, it is not sufficient to only poll the DSCP settings of packets coming in to WAAS once per flow; you should also poll periodically to identify flow changes. However, the WAAS system expects packets to appear in the sequence of packets belonging to the class C1, followed by a sequence of C2, and so forth, so that a polling method is sufficient to track such dynamic changes.



Note This dynamic classification support requires support for marking DSCP/ToS settings, as specified in [WAAS and the Cisco IOS QoS Classification Feature](#), as well as the tracking of dynamic changes through polling.

Several router configurations should be followed in order to ensure NBAR-WAAS compliance, and you must ensure that the following router configurations are adhered to:

- Ensure that classification is followed by proper DSCP marking.
- Ensure that the router in general (IP access lists that are configured on the router) does not scrub DSCP/TOS settings that are already marked on the packets on entry, and that NBAR does not unmark marked packets.

WAAS and Cisco IOS Marking

The Cisco IOS marking feature is supported by the WAAS software.

WAAS and Cisco IOS Queuing

The Cisco IOS queuing feature for congestion management is supported by the WAAS software.

WAAS and Cisco IOS Congestion Avoidance

The Cisco IOS congestion avoidance feature is supported by the WAAS software.

WAAS and Cisco IOS Traffic Policing and Rate Limiting

The Cisco IOS traffic policing and rate-limiting feature is only partially supported by the WAAS software. This Cisco IOS feature will work properly when enabled on an outbound interface. However, when this feature is enabled on an inbound interface, it will see both compressed and uncompressed traffic, and will result in inaccurate rate limiting.

WAAS and Cisco IOS Signaling

The Cisco IOS signaling (RSVP) feature is typically implemented in Multiprotocol Label Switching (MPLS) networks. Because the WAAS software does not interact with MPLS RSVP messages, the RSVP feature is supported.

WAAS and Cisco IOS Link-Efficiency Operations

The Cisco IOS link-efficiency operations are supported by the WAAS software.

WAAS and Cisco IOS Provisioning, Monitoring, and Management

The Cisco IOS AutoQoS feature is supported by the WAAS software, but requires additional configuration. This feature is closely connected with NBAR support because the AutoQoS feature uses NBAR to discover the various flows on the network. However, because the Cisco IOS AutoQoS feature is strictly on an outbound feature, for example, it cannot be enabled on the inbound side of an interface, this situation could create a potential problem because enabling NBAR on the outbound interface is not supported.

To avoid this potential problem, enable the trust option of the AutoQoS feature on the following interfaces so that classification and queuing are performed based on the marked value (NBAR is not enabled on the outbound interface using this solution):

- On the LAN interface on which the input policy is created and on which the marking of the packets should be performed according to the AutoQoS marking, for example, interactive video mark to af41.
- On the WAN outbound interface.

WAAS and Management Instrumentation

For management instrumentation use with the WAAS software, note the following:

- When deployed in native (transparent) mode, WAAS maintains packet header information vital to technologies, such as NetFlow. NetFlow can be configured on adjacent devices and exports flow record information in accordance with where NetFlow is configured in relation to the WAAS device. For NetFlow configurations on the LAN side of a WAAS device, NetFlow exports records containing information about original flows. For NetFlow configurations on the WAN side of a WAAS device, NetFlow exports records containing information about optimized and pass-through flows.
- You may see statistics on optimized and unoptimized traffic.
- IP Service-Level Agreements (SLAs) are supported.
- Full support of policies based on Layer 3 and Layer 4 is provided. Policies based on Layer 7 are partially supported because the first few messages are unoptimized.
- Intrusion Detection System (IDS) is partially supported. The first few messages are unoptimized to allow IDS to detect intrusive strings.
- Cisco IOS security is partially supported with the exception of features that rely on Layer 5 and above visibility.
- IPsec and SSL VPN are supported.
- ACLs are supported. IP ACLs on the router take precedence over ACLs that are defined on the WAE. For more information, see [Access Lists on Routers and WAEs](#).
- VPN is supported if the VPN is deployed after WCCP interception occurs.



Note

A WAAS device does not encrypt WAN traffic. If you require additional security measures, you should use a VPN. However, the VPN appliances must encrypt and decrypt traffic after and before the WAAS devices so that the WAAS device sees only unencrypted traffic. The WAAS device is unable to compress encrypted traffic and provides only limited TCP optimization to it.

- Network Address Translation (NAT) is supported. However, payload-based NAT is not supported.

WAAS and MPLS

MPLS is partially supported by the WAAS software. WCCP does not know how to operate with packets that are tagged with MPLS labels. Consequently, inside the cloud, WCCP redirection will not function, for example, WCCP redirection will not work for intermediate WAEs. However, as long as redirection occurs on interfaces that are outside the MPLS cloud, WAAS is supported.

WAAS AOs Interoperability with Third-Party Load Balancers

A load balancer is used to balance network and application traffic across a set of servers, The resulting evenly-distributed traffic improves the response rate of network traffic, increases the availability of applications, and minimizes the risk of a single server becoming overloaded.

Table 2-1 shows the interoperability between WAAS application accelerators (AOs) and the F5 load balancer. For more information about WAAS load balancing, see [About Traffic Interception Methods](#) and [Configuring Policy-Based Routing](#) in the “Configuring Traffic Interception” chapter of this Configuration Guide, and also see the *Server Load-Balancing Guide vA5(1.0)*, *Cisco ACE Application Control Engine*.

**Note**

WAAS does not currently support Citrix NetScaler load balancer.

Table 2-1 WAAS AOs Interoperability with Load Balancers

WAAS Status	Load Balancer Status	Authentication Method	WAAS AO Supported/ Not Supported
WAAS enabled	F5 enabled	Kerberos	<ul style="list-style-type: none"> EMAPI not supported SSL not supported
WAAS disabled	F5 enabled	Kerberos	<ul style="list-style-type: none"> EMAPI supported SSL supported
WAAS enabled	F5 disabled	Kerberos	<ul style="list-style-type: none"> EMAPI supported SSL supported
WAAS enabled	F5 enabled	NTLM	<ul style="list-style-type: none"> EMAPI supported SSL not supported

WAAS Compatibility with Other Cisco Appliances and Software

If a firewall is placed between the clients and the WAE on one side, and the router on the other side of the firewall, default WCCP redirection does not work. However, if there is a router inside the firewall and another router outside the firewall, the default WCCP-based redirection does work and WAAS is supported.

**Note**

Cisco Application and Content Networking Software (ACNS) devices, used with earlier WAAS versions to optimize web protocols, is end-of-life/end-of-sale. For more information, including migration options, see the [End-of-Sale and End-of-Life Announcement for the Cisco Application and Content Networking System \(ANCS\) Software Version 5.5](#).

WAAS Devices and Device Mode

You must deploy the WAAS Central Manager on a dedicated appliance. Although the WAAS Central Manager device runs the WAAS software, its only purpose is to provide management functions. WAAS Central Manager communicates with the WAEs, that are registered with it in the network. Through the WAAS Central Manager GUI, you can centrally manage the configuration of the WAEs individually or in groups. The WAAS Central Manager also gathers management statistics and logs for its registered WAEs.

A WAE also runs the WAAS software, but its role is to act as an accelerator in the WAAS network.

In a WAAS network, you must deploy a WAAS device in one of the following device modes:

- WAAS Central Manager mode—Mode that the WAAS Central Manager uses.
- WAAS application accelerator mode—Mode that a WAAS Accelerator (data center WAEs and branch WAEs that run the WAAS software) uses to optimize and accelerate traffic.
- WAAS AppNav Controller mode—Mode for a WAAS device that is operating as an AppNav Controller that is intercepting and distributing traffic to other WAAS devices operating in application accelerator mode.

The default device mode for a WAAS device is WAAS accelerator mode. The **device mode** global configuration command allows you to change the device mode of a WAAS device.

For example, after you use the WAAS CLI to specify the basic network parameters for the designated WAAS Central Manager (the WAAS device named `waas-cm`) and assign it a primary interface, you can use the **device mode** configuration command to specify its device mode as central manager. You can also specify it to be set up as an IPv4 or an IPv6 interface during basic configuration. The following example shows the configuration of an IPv6 interface.

```

waas-cm# configure
waas-cm(config)# primary-interface gigabitEthernet 1/0 IPv6
waas-cm(config)# device mode central-manager
waas-cm(config)# exit
waas-cm# copy run start
waas-cm# reload
Proceed with reload?[confirm]yes
Shutting down all services, will timeout in 15 minutes.
reload in progress ..

```

**Note**

WAAS Version 6.1.1 and later supports IPv6. If you are configuring the WAAS CM as part of a dual-stack network, and you are using an IPv6 interface on the WAAS CM, you must specify the virtual interface as the primary interface for IPv6 traffic, using the global configuration command **primary-interface virtual 1/0 ipv6**.

Specifying the virtual interface as the primary interface for IPv6 traffic ensures that a device configured with IPv6 address only will be in Online state after registration to the WAAS CM. Otherwise, the device may go into Offline state when it is registered to the WAAS CM.

For more information on the **primary-interface** global configuration command, see the [Cisco Wide Area Application Services Command Reference](#).

For more information about how to initially configure a WAAS device, see the [Cisco Wide Area Application Services Quick Configuration Guide](#).

**Note**

You cannot configure a WAE network module in the NME-WAE or SRE-SM family of devices to operate in WAAS Central Manager mode.

You can configure a WAE with a Cisco WAE Inline Network Adapter to operate in WAAS Central Manager mode, but the inline interception functionality is not available.

Changing Device Mode

If you want to change the device mode of a device that is already registered with a Central Manager, you must first deregister the device from the Central Manager, change the device mode, reload the device, and then re-enable CMS services.

The following steps show how to change the device mode from application-accelerator to appnav-controller:

Step 1 Deregister the device from the Central Manager:

```
wae# cms deregister
```

```
Deregistering WAE device from Central Manager will result in loss of data on encrypted
file systems.
imported certificate/private keys for SSL service.If secure store is initialized and open,
clear secure store.
If encrypted MAPI is enabled, windows-domain encryption-service identities will be
disabled. The passwords must be re-entered again the next time the WAE joins a central
manager.
Do you really want to continue (yes|no) [no]?yes
Disabling management service.
management services stopped
Sending de-registration request to CM
SSMGR RETURNING: 7 (Success)
Removing cms database tables.
Re-initializing SSL managed store and restarting SSL accelerator.
Deregistration complete. Save current cli configuration using 'copy running-config
startup-config' command because CMS service has been disabled.
```

Step 2 Change the device mode to appnav-controller:

```
wae# configure
wae(config)# device mode appnav-controller
The new configuration will take effect after reload.
```

Step 3 Save the configuration and reload:

```
wae(config)# exit
wae# copy run start
wae# reload
Proceed with reload?[confirm]yes
Proceed with clean WCCP shutdown?[confirm]yes

WCCP clean shutdown initiated
Waiting for shutdown ok (1 seconds) . Press ^C to skip waiting
WCCP clean shutdown wait time expired
Shutting down all services, will timeout in 15 minutes.
reload in progress ..
```

Step 4 Log in to the WAE after it finished rebooting:

```
AppNav Controller

wae login: admin
Password:
System Initialization Finished.
wae#
```

Step 5 Re-enable CMS services:

```
wae# config
```

```
wae(config)# cms enable
Registering WAAS AppNav Controller...
Sending device registration request to Central Manager with address 10.43.65.50
Please wait, initializing CMS tables
Successfully initialized CMS tables
Registration complete.
Please preserve running configuration using 'copy running-config startup-config'.
Otherwise management service will not be started on reload and node will be shown
'offline' in WAAS Central Manager UI.
management services enabled
```

Step 6 Save the configuration:

```
wae(config)# exit
wae# copy run start
```

**Note**

On platforms WAVE-7571 and WAVE-8541, if the device mode is changed to **Appnav controller**, the connection limit is reduced for certain accelerators.

Platform	Application Accelerator	Appnav-mode
7571	60,000	50,000
8541	1,50,000	1,40,000

Calculating the Number of WAAS Devices Required

When the threshold value of an operational system aspect is exceeded, Cisco WAAS may not meet its expected service level. This situation might result in degraded performance.

The source of the limitation might originate from a specific Cisco WAAS device (WAAS Central Manager, branch WAE, or data center WAE), the entire Cisco WAAS system, a hardware constraint, or the network connecting the distributed software entities. In some cases, the limitation might be resolved by adding more resources or by upgrading the hardware or software.

When planning your network, consider the operational capacity, such as the number of users it should support, how many files it should support, and how much data it should cache.

When planning your WAAS network, refer to the following additional guidelines:

- Number of WAAS Central Managers— All networks must have at least one WAAS Central Manager. For larger networks, you should consider deploying two WAAS Central Managers for active and standby backup, high availability, and failover. A WAAS Central Manager is deployed on a dedicated appliance.
- Number of WAEs—A minimum of two WAEs are required for traffic optimization; one WAE is required on either side of a network link, for example, one in the branch office and one in the data center. A single site can have more than one WAE for redundancy purposes.
- Number of branch WAEs—At least one branch WAE is required in each remote office. Larger offices usually have multiple departments whose users work with different servers in the central office. In such a scenario, you can manage your system better by following the organizational structure with

a branch WAE for each department. In certain situations, multiple branch WAEs can be clustered and configured using WCCP to provide failover capabilities. WCCP is the recommended method for larger user populations.

- Number of data center WAEs—Each organization must have at least one data center WAE.
- Number of ANCs—If you are using the AppNav deployment model, at least one ANC is required.

When determining the number of the component types required by your organization, consider the following factors:

- Number of users connecting to the system—This number depends on the static and dynamic capacities defined for the system:
 - Static capacities—Defines the number of user sessions that can connect to the system before it reaches its capacity.
 - Dynamic capacities—Defines the amount of traffic handled by the servers, which means the amount of work being performed on the network. For example, consider whether the users currently connected to the system place a heavy or light load on it.

**Note**

You should calculate dynamic limits based on the specific load assumptions that are particular to each customer.

- Total number of users in all the branches that connect to the file servers through the data center WAE— When the number of users is more than what one data center WAE can support, you must add one or more additional data center WAEs to the network.

Supported Methods of Traffic Redirection

In a WAAS network, traffic between the clients in the branch offices and the servers in the data center can be redirected to WAEs for optimization, redundancy elimination, and compression. Traffic is intercepted and redirected to WAEs based on the policies that have been configured on the routers. The network elements that transparently redirect requests to a local WAE can be a router using WCCP version 2 or PBR to transparently redirect traffic to the local WAE or a Layer 4 to Layer 7 switch, for example, the Catalyst 6500 Series Content Switching Module (CSM) or Application Control Engine (ACE).

Alternatively, a WAE that has the Cisco WAE Inline Network Adapter or Cisco Interface Module installed can operate in inline mode and receive and optimize traffic directly before it passes through the router.

In an AppNav deployment, an AppNav Controller in the data center receives intercepted traffic through WCCP, PBR, or inline mode, and distributes it to WAAS nodes that optimize the traffic. For more information on an AppNav deployment, see [Chapter 4, “Configuring AppNav.”](#)

This section contains the following topics:

- [Advantages and Disadvantages of Using Inline Interception](#)
- [Advantages and Disadvantages of Using WCCP](#)
- [Advantages and Disadvantages of Using PBR](#)
- [Configuring WCCP or PBR Routing for WAAS Traffic](#)

For detailed information about how to configure traffic interception for your WAAS network, see [Chapter 5, “Configuring Traffic Interception.”](#)

Advantages and Disadvantages of Using Inline Interception

Inline interception requires usage of a WAE appliance that has the Cisco WAE Inline Network Adapter, Cisco Interface Module, or Cisco AppNav Controller Interface Module installed. In inline mode, the WAE can physically and transparently intercept traffic between the clients and the router. When using this mode, you physically position the WAE device in the path of the traffic that you want to optimize, typically between a switch and a router.

Because redirection of traffic is not necessary, inline interception simplifies deployment and avoids the complexity of configuring WCCP or PBR on the routers.

The inline adapter or module contains one or more pairs of LAN/WAN Ethernet ports, each grouped into an inline or bridge group interface. If the inline adapter or module has multiple pairs of ports, it can connect to multiple routers if the network topology requires it.

The inline or bridge group interface transparently intercepts the traffic flowing through it or bridges traffic that does not have to be optimized. It also uses a mechanical fail-safe design that automatically bridges traffic if a power, hardware, or unrecoverable software failure occurs.



Note

The AppNav Controller Interface Modules do not support automatic bypass mode to continue traffic flow in the event of a failure. For high availability, two or more AppNav Controller Interface Modules should be deployed in an AppNav cluster. For more information on using inline mode with the AppNav solution, see [Chapter 4, “Configuring AppNav.”](#)

You can configure the inline or bridge group interface to accept traffic only from certain VLANs; for all other VLANs, traffic is bridged, and not processed. You can serially cluster WAE devices (not AppNav Controllers) in inline mode to provide higher availability in the event of a device failure. If the current optimizing device fails, the second WAE device in the cluster provides the optimization services. Deploying WAE devices in a serial inline cluster for the purposes of scaling or load balancing is not supported.

Any combination of traffic interception mechanisms on peer WAEs is supported. For example, you can use inline interception on the branch WAE and WCCP on the data center WAE. For complex data center deployments, we recommend that you use hardware-accelerated WCCP interception or load balancing with the Cisco Application Control Engine (ACE) and a WAAS AppNav deployment.

For more information on inline interception, see [Using Inline Mode Interception](#) in Chapter 5, “Configuring Traffic Interception.”

Three elements can help ease traffic interception in data centers without using a WCCP-based approach:

- Multiple pairs of inline interfaces are available on certain WAE models:
- WAVE-294/594/694/7541/7571/8541 models support one installed Cisco Interface Module, which can be configured with up to 16 inline ports in 8 inline groups, or one installed AppNav Controller Interface Module, which can be configured with up to 12 inline ports in 5 bridge groups. Serial inline clustering of two WAEs (not AppNav Controllers) to support high availability.
- Interception ACLs to control the traffic that is intercepted and what is passed through. For more information on interception ACLs, see [Configuring Interception Access Control Lists](#) in Chapter 5, “Configuring Traffic Interception.”

Advantages and Disadvantages of Using WCCP

WCCP (Web Cache Communication Protocol) specifies interactions between one or more routers (or Layer 3 switches) and one or more application appliances, web caches, and caches of other application protocols. The purpose of the interaction is to establish and maintain the transparent redirection of selected types of traffic flowing through a group of routers. The selected traffic is redirected to a group of appliances.

WCCP allows you to transparently redirect client requests to a WAE for processing. The WAAS software supports transparent intercept of all TCP traffic.

To configure basic WCCP, enable “WCCP” as the “interception method” on the router and WAE or ANC in the data center, and the router or WAE in the branch office. By default, WCCP Version 2 is used with WAAS. You do not have to configure all of the available WCCP features or services in order to get a WAE up and running.



Note

You must configure the routers and WAEs to use WCCP Version 2 instead of WCCP Version 1, because WCCP Version 1 supports only web traffic (Port 80). The routers must be running a version of Cisco IOS software that also supports WCCP Version 2.

WCCP is much simpler to configure than PBR. However, you should have write access to the router in order to configure WCCP on the router, which typically resides in the data center and on the edge of the branch office. Another advantage of using WCCP is that you have to perform only a basic configuration of WCCP on your routers and WAEs in order to get your WAE up and running.

The WCCP Version 2 protocol also has a set of useful features built-in, for example, automatic failover and load balancing between multiple devices. The WCCP-enabled router monitors the liveliness of each WAE or ANC that is attached to it through the WCCP keepalive messages. If a WAE goes down, the router stops redirecting packets to the WAE. When you use WCCP Version 2, the branch WAE is not made a single point of failure for the WAAS services. The router or ANC can also load balance the traffic among a number of branch WAEs.

You can use CLI commands to configure basic WCCP on both the routers and the WAEs, or you can use CLI commands to configure the router for WCCP and use the WAAS Central Manager GUI to configure basic WCCP on the WAEs.

We recommend that you use the WAAS CLI to complete the initial basic configuration of WCCP on your first branch WAE and data center WAE, as described in the *Cisco Wide Area Application Services Quick Configuration Guide*. After you have verified that WCCP transparent redirection is working properly, you can use the WAAS Central Manager GUI to centrally modify this basic WCCP configuration or configure additional WCCP settings, for example, load balancing, for a WAE (or group of WAEs). For more information, see [Configuring WCCP on WAEs](#) in Chapter 5, “Configuring Traffic Interception.” After you have configured basic WCCP on the router, you can configure advanced WCCP features on the router, as described in the [Configuring Advanced WCCP Features on Routers](#) in Chapter 5, “Configuring Traffic Interception.”

Advantages and Disadvantages of Using PBR

PBR allows IT organizations to configure their network devices (a router or a Layer 4 to Layer 6 switch) to selectively route traffic to the next hop, based on the classification of the traffic. WAAS administrators can use PBR to transparently integrate a WAE into their existing branch office network and data centers. PBR can be used to establish a route that goes through a WAE for some or all packets, based on the defined policies.

To configure PBR, you must create a route map and then apply the route map to the router interface on which you want the transparent traffic redirection to occur. Route maps reference access lists that contain explicit permit or deny criteria. The access lists define the traffic that is *interesting* to the WAE, that is, traffic that the network device should transparently intercept and redirect to the local WAE. Route maps define how the network device should handle *interesting* traffic, for example, send the packet to the next hop, which is the local WAE.

The following list summarizes the main advantages of using PBR instead of WCCP Version 2 to transparently redirect IP/TCP traffic to a WAE:

- PBR provides higher performance than WCCP Version 2 because there is no GRE overhead.
- By default PBR uses CEF when CEF is enabled on the router. (PBR uses CEF for fast switching of packets.)
- PBR can be implemented on any Cisco IOS-capable router or a switch that is running an appropriate version of the Cisco IOS software. We recommend that you use Cisco IOS Software Release 12.2 or later.
- PBR provides failover if multiple next-hop addresses are defined.

The following list summarizes the main disadvantages of using PBR instead of WCCP Version 2 to transparently redirect IP/TCP traffic to a WAE:

- PBR does not support load balancing between equal cost routes. Consequently, PBR does not provide scalability for the deployment location.
- PBR is more difficult to configure than WCCP Version 2. For an example of how to configure PBR for WAAS traffic, see the [Using Policy-Based Routing Interception](#) in Chapter 5, “Configuring Traffic Interception.”

Configuring WCCP or PBR Routing for WAAS Traffic

The primary function of WAAS is to accelerate WAN traffic. In general, WAAS accelerates TCP traffic, and uses a symmetric approach for application optimization. A WAE that has application-specific and network-specific intelligence is placed on each side of the WAN. These WAEs are deployed out of the data path in both the branch office and the data center.

Traffic between the clients in the branch offices and the servers at the data center is transparently redirected through the WAEs based on a set of configured policies with no tunneling. The routers use WCCP Version 2 or PBR to transparently intercept and redirect traffic to the local WAE for optimization, redundancy elimination, and compression. For example, Edge-Router1 uses PBR or WCCP Version 2 to transparently redirect traffic to Edge-WAE1, the local WAE in the branch office. Core-Router1 uses PBR or WCCP Version 2 to transparently redirect traffic to Core-WAE1, the local WAE in the data center.



Note

In this sample deployment, Edge-Router1 and Core-Router1 can be replaced with Layer 4 to Layer 7 switches, which are capable of redirecting traffic to the local WAE.

[Figure 2-1](#) shows that the WAEs (Edge-WAE1 and Core-WAE1) must reside in an out-of-band network that is separate from the traffic’s destination and source. For example, Edge-WAE1 is on a subnet that is separate from the clients (the traffic source), and Core-WAE1 is on a subnet that is separate from the file servers and application servers (the traffic destination). Additionally, you may have to use a tertiary interface (a separate physical interface) or a subinterface to attach a WAE to the router, which redirects traffic to it, in order to avoid an infinite routing loop between the WAE and the router. For more information about this, see [Using Tertiary Interfaces or Subinterfaces to Connect WAEs to Routers](#).

Figure 2-1 Using PBR or WCCP Version 2 for Transparent Redirection of All TCP Traffic to WAEs

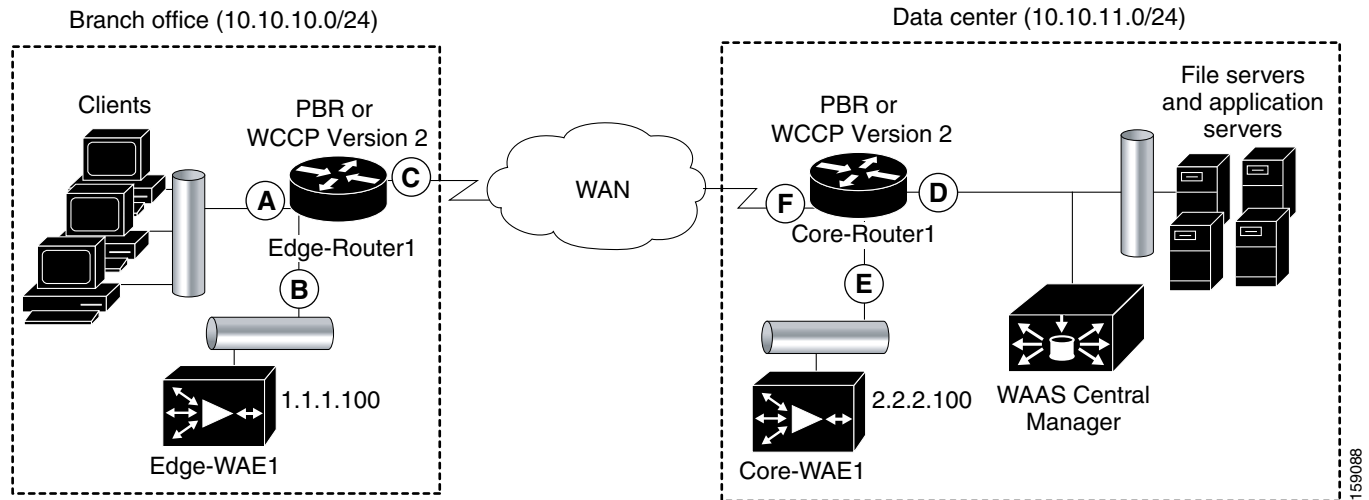

Table 2-2 provides a summary of the router interfaces that you must configure to use PBR or WCCP Version 2 to transparently redirect traffic to a WAE.

Table 2-2 Router Interfaces for WCCP or PBR Traffic Redirection to WAEs

Router interface	Description
Edge-Router1	
A	Edge LAN interface (ingress interface) that performs redirection on the outbound traffic.
B	Tertiary interface (separate physical interface) or a subinterface off of the LAN port on Edge-Router1. Used to attach Edge-WAE1 to Edge-Router1 in the branch office.
C	Edge WAN interface (egress interface) on Edge-Router1 that performs redirection on the inbound traffic.
Core-Router1	
D	Core LAN interface (ingress interface) that performs redirection on outbound traffic.
E	Tertiary interface or subinterface off of the LAN port on Core-Router1. Used to attach Core-WAE1 to Core-Router1 in the data center.
F	Core WAN interface (egress interface) on Core-Router1 that performs redirection on the inbound traffic.

This traffic redirection does not use tunneling; the full original quadruple (source IP address, source port number, destination IP address, and destination port number) of the TCP traffic is preserved end to end. The original payload of the TCP traffic is not preserved end to end because the primary function of WAAS is to accelerate WAN traffic by reducing the data that is transferred across the WAN. This change in payload can potentially impact features on the router that is performing the WCCP or PBR redirection, and that needs to see the actual payload to perform its operation, for example, NBAR. For more information on this topic, see [WAAS and Cisco IOS Interoperability](#).

Using WCCP or PBR at both ends with no tunneling requires that traffic is intercepted and redirected not only in the near-end router but also at the far-end router, which requires four interception points, as opposed to two interception points in a tunnel-based mode.

You can enable packet redirection on either an outbound interface or inbound interface of a WCCP-enabled router. The terms *outbound* and *inbound* are defined from the perspective of the interface. Inbound redirection specifies that traffic should be redirected as it is being received on a given interface. Outbound redirection specifies that traffic should be redirected as it is leaving a given interface.

If you are deploying WAN optimization in your WAAS network, you must configure the router and WAE for WCCP Version 2 and the TCP promiscuous mode service (WCCP Version 2 services 61 and 62 by default).

**Note**

Services 61 and 62 are always enabled together when configuring TCP promiscuous mode on the WAE. Services 61 and 62 must be defined and configured separately when configuring TCP promiscuous mode on the network device (router, switch, or other). Service 61 distributes traffic by source IP address, and service 62 distributes traffic by destination IP address. The service IDs are configurable; 61 and 62 are the defaults.

The TCP promiscuous mode service intercepts all the TCP traffic that is destined for any TCP port and transparently redirects it to the WAE. The WCCP-enabled router uses service IDs 61 and 62 to access this service. The service IDs used on the router must match those on the WAE if service IDs that are different from the defaults are configured.

By default, IP Protocol 6 is specified for the TCP promiscuous mode service. Consequently, the routers that have been configured to the TCP promiscuous mode service will intercept all the TCP traffic destined for any TCP port to the local WAE. Because the TCP promiscuous mode service is configured on the WAE, the WAE will accept all of the TCP traffic that is transparently redirected to it by specified WCCP routers, for example, Edge-WAE1 will accept all TCP traffic that Edge-Router1 redirects to it. In the branch office, you can intercept packets at the edge LAN and WAN interfaces on the Edge routers and redirect the TCP traffic to the local WAE (the branch WAE). In the data center, you can intercept packets at the core LAN and WAN interfaces on the core routers and redirect the TCP traffic to the local WAE (the data center WAE). For more information, see [Configuring WAEs as Promiscuous TCP Devices in a WAAS Network](#).

Configure packet redirection on inbound interfaces of branch software routers whenever possible. Inbound traffic can be configured to use Cisco Express Forwarding (CEF), distributed Cisco Express Forwarding (dCEF), fast forwarding, or process forwarding.

**Note**

CEF is required for WCCP, and must be enabled on the router.

To enable packet redirection on a router's outbound or inbound interface using WCCP, use the **ip wccp redirect** interface configuration command.

**Caution**

The **ip wccp redirect** interface command has the potential to affect the **ip wccp redirect exclude in** command. If you have **ip wccp redirect exclude in** set on an interface and you subsequently configure the **ip wccp redirect in** command, the **exclude in** command is overridden. If you configure the **exclude in** command, the **redirect in** command is overridden.

This section contains the following topics:

- [Configuring WAEs as Promiscuous TCP Devices in a WAAS Network](#)
- [Using Tertiary Interfaces or Subinterfaces to Connect WAEs to Routers](#)

Configuring WAEs as Promiscuous TCP Devices in a WAAS Network

For a WAE to function as a promiscuous TCP device for the TCP traffic that is transparently redirected to it by the specified WCCP Version 2 routers, the WAE uses WCCP Version 2 services 61 and 62 by default, though the service IDs are configurable. The WCCP services are represented by the canonical name `tcp-promiscuous` on the WAE CLI and TCP Promiscuous in the WAAS Central Manager GUI. (See [Figure 5-3](#).)

For instructions on how to perform a basic WCCP configuration for a WAAS network, see the *Cisco Wide Area Application Services Quick Configuration Guide*. For instructions about how to use the WAAS Central Manager GUI to modify the basic WCCP configuration for a WAE, see [Configuring WCCP on WAEs](#) in Chapter 5, “Configuring Traffic Interception.”

Using Tertiary Interfaces or Subinterfaces to Connect WAEs to Routers

If you plan to use WCCP Version 2 or PBR to transparently redirect TCP traffic to a WAE, make sure that the WAE is not attached to the same segment as the router interface on which the traffic redirection is to occur. Otherwise, an infinite routing loop between the router and the WAE will occur. These infinite routing loops occur because there is no way to notify the router to bypass the interception and redirection after it has redirected the traffic to the WAE the first time; the router will continuously redirect the same intercepted traffic to the local WAE, creating the infinite routing loop.



Note

The WCCP GRE return and generic GRE egress methods allow you to place WAEs on the same VLAN or subnet as clients and servers. For information on configuring these egress methods, see [Configuring Egress Methods for WCCP-Intercepted Connections](#) in Chapter 5, “Configuring Traffic Interception.”

For example, if you attach Edge-WAE 1 to the same segment (subnet) as the LAN router interface on which the PBR or WCCP traffic redirection occurs in the branch office, there will be an infinite routing loop between Edge-Router1 and Edge-WAE1. If you attach Core-WAE1 to the same segment (subnet) as the LAN router interface on which the PBR or WCCP traffic redirection occurs in the data center, there will be an infinite routing loop between Core-Router1 and Core-WAE1.

To avoid an infinite routing loop between the router and its local WAE, connect the WAE to the router through a tertiary interface (a separate physical interface) or a subinterface (a different virtual subinterface) from the router’s LAN port. By using a tertiary interface or a subinterface to connect a WAE to the router that is performing the PBR or WCCP redirection, the WAE has its own separate processing path that has no Cisco IOS features enabled on it. In addition, this approach simplifies the process of integrating WAEs into an existing network. Because the WAEs are being connected to the routers through a tertiary interface or subinterface that has no Cisco IOS features enabled on it, the Cisco IOS features that are already enabled on your existing Cisco-enabled network elements, for example, Edge-Router1 or Core-Router1, will generally not be affected when you connect WAEs to these routers. For more information about WAAS and Cisco IOS interoperability, see [WAAS and Cisco IOS Interoperability](#).

See the *Cisco Wide Area Application Services Quick Configuration Guide* for an example of how to use a subinterface to properly attach a local WAE to the router that is redirecting TCP traffic to it.

Access Lists on Routers and WAEs

You can optionally configure the router to redirect traffic from your WAE based on the access lists that you define on the router. These access lists are also referred to as redirect lists. For information about how to configure access lists on routers that will be configured to transparently redirect traffic to a WAE, see [Configuring IP Access Lists on a Router](#) in Chapter 5, “Configuring Traffic Interception.”

**Note**

IP access lists on routers have the highest priority, followed by IP ACLs that are defined on the WAEs, and then interception ACLs that are defined on the WAEs.

This section contains the following topics:

- [IP ACLs on WAEs](#)
- [Interception ACLs on WAEs](#)

IP ACLs on WAEs

In a centrally managed WAAS network environment, administrators need to be able to prevent unauthorized access to various devices and services. The WAAS software supports standard and extended IP access control lists (ACLs) that allow you to restrict access to or through particular interfaces on a WAAS device. For more information, see [Chapter 9, “Creating and Managing IP Access Control Lists for Cisco WAAS Devices.”](#)

**Note**

IP ACLs that are applied on interfaces, and WCCP ACLs, always take precedence over any interception ACLs and WAAS application definitions, if any, that have been defined on the WAE.

Interception ACLs on WAEs

You can configure an interception ACL to control what incoming traffic across all interfaces should be intercepted by a WAE device. Packets that are permitted by the ACL are intercepted by the WAE and packets that are denied by the ACL are passed through the WAE without processing. By configuring interception ACLs on the WAE, you can control traffic interception without modifying the router configuration.

An interception ACL can be used both with WCCP and inline interception.

Interception ACLs that are defined on a WAE always take precedence over any WAAS application definitions that have been defined on the WAE, but they are applied after interface ACLs and WCCP ACLs.

For information about how to configure an interception ACL for a WAE, see the [Configuring Interception Access Control Lists](#) in Chapter 5, “Configuring Traffic Interception.”

WAAS Login Authentication and Authorization

In the WAAS network, administrative login authentication and authorization are used to control login requests from administrators who want to access a WAAS device for configuring, monitoring, or troubleshooting purposes.

Login authentication is the process by which WAAS devices verify whether the administrator who is attempting to log in to the device has a valid username and password. The administrator who is logging in must have a user account registered with the device. User account information serves to authorize the user for administrative login and configuration privileges. The user account information is stored in an AAA database, and the WAAS devices must be configured to access the particular authentication server (or servers) where the AAA database is located. When the user attempts to log in to a device, the device compares the person's username, password, and privilege level to the user account information that is stored in the database.

The WAAS software provides the following authentication, authorization, and accounting (AAA) support for users who have external access servers, for example, RADIUS, TACACS+, or Windows domain servers, and for users who need a local access database with AAA features:

- *Authentication* (or *login authentication*) is the action of determining who the user is. It checks the username and password.
- *Authorization* (or *configuration*) is the action of determining what a user is allowed to do. It permits or denies privileges for authenticated users in the network. Generally, authentication precedes authorization. Both authentication and authorization are required for a user log in.
- *Accounting* is the action of keeping track of administrative user activities for system accounting purposes. In the WAAS software, AAA accounting through TACACS+ is supported.

For more information, see [Configuring AAA Accounting for WAAS Devices](#) in Chapter 7, “Configuring Administrative Login Authentication, Authorization, and Accounting.”

WAAS Administrator Accounts

In a centrally managed WAAS network, administrator accounts can be created for access to the WAAS Central Manager and, independently, for access to the WAEs that are registered with the WAAS Central Manager. There are two distinct types of accounts for WAAS administrators:

- **Role-based accounts**—Allows users to access the WAAS Central Manager GUI, the WAAS Central Manager CLI, and the WAE Device Manager GUI. The WAAS software has a default WAAS system user account (username is `admin` and password is `default`) that is assigned the role of administrator.
- **Device-based CLI accounts**—Allows users to access the WAAS CLI on a WAAS device. These accounts are also referred to as local user accounts.



Note

An administrator can log in to the WAAS Central Manager device through the console port or the WAAS Central Manager GUI. An administrator can log in to a WAAS device that is functioning as a data center or branch WAE through the console port or the WAE Device Manager GUI.

A WAAS device that is running WAAS software comes with a predefined superuser account that can be used initially to access the device. When the system administrator logs in to a WAAS device before authentication and authorization have been configured, the administrator can access the WAAS device by using the predefined superuser account (the predefined username is `admin` and the predefined password is `default`). When you log in to a WAAS device using this predefined superuser account, you are granted access to all the WAAS services and entities in the WAAS system.

After you have initially configured your WAAS devices, we strongly recommend that you immediately change the password for the predefined superuser account (the predefined username is `admin`, the password is `default`, and the privilege level is superuser, privilege level 15) on each WAAS device. For

instructions on how to use the WAAS Central Manager GUI to change the password, see [Changing the Password for Your Own Account](#) in Chapter 8, “Creating and Managing Administrative User Accounts and Groups.”

Logically Grouping Your WAEs

To streamline the configuration and maintenance of WAEs that are registered with a WAAS Central Manager, you can create a logical group and then assign one or more of your WAEs to the group. Groups not only save you time when configuring multiple WAEs, but they also ensure that configuration settings are applied consistently across your WAAS network. For example, you can set up a WinAuth group that defines the standard Windows authentication configuration that is wanted for all of the WAEs in that group. After you define the WinAuth settings once, you can centrally apply those values to all of the WAEs in the WinAuth group instead of defining these same settings individually on each WAE.

With the WAAS Central Manager GUI, you can easily organize your branch and data center WAEs into device groups, which are a collection of WAEs that share common qualities and capabilities. Setting up groups based on their authentication settings is an example of a device group.

When you create a device group, you should identify the unique characteristics that distinguish that group of WAEs from others in your network. For example, in larger WAAS deployments, one set of WAEs may have to be configured with authentication settings that are different from another set of WAEs in your WAAS network. In such a scenario, you should create two device groups, each of which contain different authentication settings, and then assign your WAEs to the most appropriate group.

If you have WAEs that reside in different time zones, you can also create device groups based on geographic regions so that the WAEs in one group can have a different time zone setting from the WAEs in another group.

In smaller WAAS deployments where all WAEs can be configured with the same settings, you may only have to create one general device group. This practice allows you to configure settings for the group, and then apply those settings consistently across all your WAEs.



Note

The AllWAASGroup and AllWAASExpressGroup are default device groups that automatically contain all WAAS and WAAS Express devices. In these or any other device groups, you should configure only the settings that you want to be consistent across all the devices in the group. Settings that apply to a single device should be configured on that device only and not on the device group.

By default, WAAS Central Manager allows you to assign a device to multiple device groups. Before you create a device group, make sure you understand the unique properties that you want the group to contain.

The WAAS Central Manager allows you to create locations that you can associate with a WAAS device. You assign a device to a location when you first activate the device. The main purpose of assigning a WAAS device to a location is to help you identify a WAAS device by the physical region in which it resides. Locations are different from device groups because devices do not inherit settings from locations.

You assign a device to a location when you activate the device, as described in the *Cisco Wide Area Application Services Quick Configuration Guide*. For more information about logically grouping your WAEs, see [Chapter 3, “Using Device Groups and Device Locations.”](#)

Data Migration Process

If you have an existing network, you must perform some tasks before setting up your WAAS network. The first step in the data migration process is to back up the data at the branch offices and restore it to the data center.

After you back up data to the data center, you should preload the cache (called *preposition*) with the files for which you want to provide the fastest access. Set up the files from your branch office file server to the WAEs that are also located in the same branch office. You can then remove the file servers from the branch offices and point to the data center file server.

The final step in the data migration process is to set the SMB policies.

When performing the data migration process, note the following restrictions:

- The topology for the file server at the data center must be identical to the topology that exists on the branch file server.
- Resource credentials (such as ACLs) are not automatically migrated. Two options are available:
 - You can use backup or restore software to restore an initial backup of the tree to the target server. This practice allows both the creation of ACLs as well as the creation of the initial file set that Rsync can take as an input for diff calculations. The replication inherits the existing ACLs in that tree.
 - The other option is to perform a first run of Robocopy (including data and permissions), and then continue with sync iterations using Rsync.

After replicating, use one of Microsoft's tools for copying only ACLs (no data) onto the replicated tree. You can use Robocopy.exe for copying the directory tree or file ACLs, and Permcop.exe to copy share permissions.

- The migration size must be less than the cache size of the branch WAE.



PART 2

Installing and Configuring Cisco WAAS



Using Device Groups and Device Locations

This chapter describes the types of device groups supported by the WAAS software and how to create groups that make it easier to manage and configure multiple devices at the same time. This chapter also discusses how to use device locations.



Note

Throughout this chapter, the term WAAS device is used to refer collectively to the WAAS Central Managers and WAEs in your network. The term WAE refers to WAE and WAVE appliances, WAE Network Modules (the NME-WAE family of devices), and SM-SRE modules running WAAS.

This chapter contains the following sections:

- [About Device Groups](#)
- [Working with Device Groups](#)
- [Working with Device Locations](#)

About Device Groups

When you create a device group, you need to identify the unique characteristics that distinguish that group of devices from others in your network. For example, in larger WAAS deployments, one set of devices may need to be configured with authentication settings that are different from another set of devices in your WAAS network. In this situation, you would create two device groups that each contain different authentication settings, and then assign your devices to the most appropriate group.

If you have devices that reside in different time zones, you can also create device groups based on geographic regions so that the devices in one group can have a different time zone setting from the devices in another group.

In smaller WAAS deployments where all devices can be configured with the same settings, you may only need to create one general device group. This setup allows you to configure settings for the group, and then apply those settings consistently across all your WAAS devices.

Groups not only save you time when configuring multiple devices, but they also ensure that configuration settings are applied consistently across your WAAS network.

There are two types of device groups: WAAS Device Groups and WAAS Express Device Groups. These groups are explained in more detail in [Creating a New Device Group](#).

When you register a WAAS device with the WAAS Central Manager, that device automatically joins the AllWAASGroup, which is the default device group on the system for WAAS devices. If you create additional device groups, you need to decide if you want your devices to belong to more than one group

(the default AllWAASGroup and the new device group you create). If you only want a device to belong to a device group that you create, make sure that you remove the device from the default AllWAASGroup. WAAS Express devices automatically join the default AllWAASExpressGroup device group when they are registered with the Central Manager.

WAAS devices and WAAS Express devices cannot be mixed in the same device group. You choose the device group type when you create the group and it cannot be changed. When you create a WAAS Express type of device group, you can copy policies from an existing WAAS or WAAS Express group, but policies cannot be copied after creation.

Working with Device Groups

This section contains the following topics:

- [Creating a Device Group](#)
- [Deleting a Device Group](#)
- [Viewing Device Group Assignments](#)
- [Viewing the Device Groups List](#)
- [Enabling or Disabling Device Group Overlap](#)
- [Overriding Group Configuration Settings](#)
- [Understanding the Impact of Assigning a Device to Multiple Device Groups](#)
- [Moving a Device Between Device Groups](#)

Creating a Device Group

This section contains the following topics:

- [Creating a New Device Group](#)
- [Configuring the Settings for a Device Group](#)
- [Assigning Devices to a Configuration Device Group](#)

Table 3-1 describes the process for creating a new device group.

Table 3-1 Checklist for Creating a Device Group

Task	Additional Information and Instructions
1. Create a new device group.	Defines general information about the new group, such as the group name, group type, and whether all newly activated devices are assigned to this group. For more information, see Creating a New Device Group .
2. Configure the settings of the new device group.	Specifies the settings that are unique to this device group. All devices that are a member of this group will automatically inherit these settings. For more information, see Configuring the Settings for a Device Group .

Table 3-1 Checklist for Creating a Device Group (continued)

Task	Additional Information and Instructions
3. Assign devices to the device group.	Assigns devices to the group so they can inherit the group settings. For more information, see Assigning Devices to a Configuration Device Group .

Creating a New Device Group

Before you create a device group, make sure you understand the unique properties that you want the group to contain. For example, you may want to set up two device groups that have different authentication settings or different time zone settings.

To create a device group, follow these steps:

-
- Step 1** From the WAAS Central Manager menu, choose **Device Groups > All Device Groups**. The Device Groups window appears.
- From this window you can perform the following tasks:
- Click the **Edit** icon next to the device group that you want to modify.
 - Create a new device group as described in the steps that follow.
- Step 2** Click the **Create New Device Group** icon in the taskbar. The Creating New Device Group window appears.
- Step 3** In the Name field, enter the name of the device group.
- The name must be unique and should be a name that is useful in distinguishing the device group from others on your system. The name cannot contain characters other than letters, numbers, period, hyphen, underscore, and space.
- Step 4** Choose either WAAS or WAAS Express for the Configuration Group Type. This sets the type of devices that the group can contain. A WAAS Express group can contain only WAAS Express devices. A WAAS group can contain all types of devices except for WAAS Express devices.
- Step 5** Check the **Automatically assign all newly activated devices to this group** check box to set this device group as the default device group for all newly activated devices.
- Step 6** If you chose the WAAS Express group type, you can copy policies from another existing group by choosing the group in the Copy Policies from the device group drop-down list (only shown when creating a WAAS Express group). If you copy policies from a WAAS group, only basic optimization policies are copied, not application acceleration policies.
- Step 7** (Optional) Enter comments about the group in the Comments field. The comments that you enter will appear in the Device Group window.
- Step 8** Click **Submit**.
- The page refreshes with additional options.



Note The Pages configured for this device group arrow lists the configuration windows in the WAAS Central Manager GUI that have been configured for this device group. Because this is a new device group, no pages will appear in this list.

- Step 9** (Optional) Customize the menu options for this device group by completing the following steps. Use this feature to remove from view any configuration windows that you do not need for that particular device group:
- Click the **Select pages to hide from table of contents for this device group** arrow.
A list of windows in the WAAS Central Manager GUI appears.
 - Check the windows that you want to hide for this device group. You can click the folder icon next to a window to display its child windows.
 - Click **Submit**.
- Step 10** Configure the settings for this device group as described in [Configuring the Settings for a Device Group](#).
-

Configuring the Settings for a Device Group

After creating a device group, you need to configure the settings that you want to be unique to this group. Consider the following when you configure device group settings:

- If you have a general device group that contains all your WAAS devices of a specific type, configure only the settings that you want to be consistent across all the devices of that type.
- Settings that apply to a single device should be configured on that device only and not on the device group.
- When a device group is created, no policies are assigned to that group unless the admin adds them.
- Note the following about the class-default policy and creating or changing device group settings:
 - After policies are added to a device group (either custom or the default set), a class-default policy is also created.
 - All of the policies in a default policy set or custom policy set *except* the class-default policy can be modified or deleted.
 - The class-default policy cannot be modified or deleted. To change the class-default policy, you must delete the device group, and then create a new device group with a new class-default policy.

To configure settings for a device group, follow these steps:

-
- Step 1** From the WAAS Central Manager menu, choose **Device Groups** > *device-group-name*.
The Modifying Device Group window appears.
- Step 2** Click the **Pages configured for this device group** arrow button to view which configuration windows have already been configured for the group.
A list of pages that are configured for that device group appears. If this is a new device group or if there are no pages configured for this device group, the list displays Null.
- Step 3** Customize the menu options for this device group by completing the following steps:
- Click the **Select pages to hide from table of contents of this device group** arrow.
A list of windows in the WAAS Central Manager GUI appears.
 - Place a check next to the windows that you want to hide for this device group. Use this feature to remove from view any configuration windows that you do not need for this particular device group.
- Step 4** Use the menu bar to choose each configuration option that you want to modify for this device group.

If the configuration option has not been configured for this device group, the message “There are currently no settings for this group” appears at the top of the window.

- Step 5** Make the necessary changes on the configuration option window, and click **Submit** when finished.
- After a particular setting is configured, the configuration window is listed under Pages configured for this device group in the Modifying Device Group window.
- Step 6** Assign devices to this new group as described in [Assigning Devices to a Configuration Device Group](#).
-

Assigning Devices to a Configuration Device Group

After you create a configuration device group, you need to assign devices to the group. The WAAS Central Manager GUI provides two methods to assign devices to a configuration group. You can either select the device first, then assign a group to the device, or you can select the device group first, then assign devices to the group.

The procedures in this section describe how to assign devices to a group. To assign a group to a device, choose **Devices** > *device-name* and choose **Assign Device Groups** from the device-name menu. You can then assign a group to the device using the same method described in steps 4 and 5 below.

You cannot assign the WAAS Central Manager to a device group. You must configure the WAAS Central Manager separately from other devices.

You cannot assign WAAS Express devices to a WAAS group and you cannot assign WAAS devices to a WAAS Express group. Invalid devices are not shown in the device list when assigning devices to groups.



Note



By default, all devices automatically join either the AllWAASGroup or AllWAASExpressGroup when they are activated. If you do not want a device to belong to one of the default device groups, you should unassign that device from the default device group, and then assign that device to a custom device group.

Generally, when assigning a device to two different Device Groups, have the same page configured in it—either have the page configured in single Device Group or it is expected to have Force Device Group (FDG) settings enabled in the other DeviceGroup. The WAAS Central Manager pushes the latest changed Device Group's configuration to the device.

Use care when you are assigning devices that have different WAAS software versions to a device group. Some features configured for a device group may not be supported by all devices in the group or, in some cases, devices may be prevented from joining the group if the group is configured with policies that they cannot support. In such cases, we recommend that you upgrade all devices to the same software version or create different device groups for devices with incompatible versions.

To assign a device to a device group, follow these steps:

-
- Step 1** From the WAAS Central Manager menu, choose **Device Groups** > *device-group-name*.
The Modifying Device Group window appears.
- Step 2** Choose *device-group-name* > **Assign Devices**.
The WAE/WAAS Express Assignments window appears, displaying the devices assigned to various locations. If you are editing a WAAS group, only WAAS devices are shown. If you are editing a WAAS Express group, only WAAS Express devices are shown.
The assignments window lets you filter your view of the items in the list. Filtering allows you to find items in the list that match the criteria that you set.

- Step 3** Assign a device to the device group by doing either of the following:
- Click  in the taskbar to assign all available devices to the group.
 - Click  next to each device that you want to assign to the group. The icon changes to  when selected.
- Step 4** Click **Submit**.
- A green check mark appears next to the assigned devices.
- Step 5** Click the **Unassign** icon (green check mark) next to the name of the device that you want to remove from the device group. Alternatively, you can click the **Remove all** icon in the taskbar to remove all devices from the selected device group. Click **Submit**.
-

Deleting a Device Group

To delete a device group, follow these steps:

- Step 1** From the WAAS Central Manager menu, choose **Device Groups** > *device-group-name*. The Modifying Device Group window appears.
- Step 2** In the taskbar, click the **Delete Device Group** icon. You are prompted to confirm your decision to delete the device group.
- Step 3** To confirm your decision, click **OK**.
-

Viewing Device Group Assignments

The WAAS Central Manager GUI allows you to view the groups that a device belongs to, as well as the devices that belong to a specific group. This section describes both of these procedures.

To view the groups that a device belongs to, follow these steps:

- Step 1** From the WAAS Central Manager menu, choose **Devices** > *device-name*.
- The Device Dashboard window appears.
- Step 2** In the Assignments field on the Device Dashboard window, click the link that displays the groups to which the device is assigned.
- The Device Group Assignments page appears, which shows all the device groups in your WAAS network that match the device type (WAAS or WAAS Express). The device is assigned to the device groups with a green check mark next to them.
- You can also go to the Device Group Assignments window by choosing the Assign Device Groups option in the menu bar.
-

To view the devices that are assigned to a specific group, follow these steps:

- Step 1** From the WAAS Central Manager menu, choose **Device Groups** > *device-group-name*.
-

The Modifying Device Group window appears.

Step 2 Choose *device-group-name* > **Assign Devices**.

The WAE/WAAS Express Assignments window appears, which shows all the WAAS or WAAS Express devices on your WAAS network. The devices with a green check mark next to them are assigned to this group.

Viewing the Device Groups List

The Device Groups window lists all the device groups that have been created in your WAAS network. To view this list, choose **Device Groups** > **All Device Groups** in the WAAS Central Manager menu bar.

This window displays the following information about each device group:

- Type of device group (WAAS Configuration Group or WAAS Express Configuration Group).
- Any comments that were entered when the device group was created.

From this window, you can perform the following tasks:

- Create a new device group. For more information, see [Creating a New Device Group](#).
- Modify the settings of a device group by clicking the **Edit** icon next to the group that you want to edit.

Enabling or Disabling Device Group Overlap

By default, you can assign a device to multiple device groups. You can disable this functionality so a device can only belong to one device group, which eliminates the possibility of a device inheriting settings from more than one group.

To enable or disable device group overlap, follow these steps:

Step 1 From the WAAS Central Manager menu, choose **Configure** > **Global** > **System Properties**.

The Config Properties window appears.

Step 2 Click the **Edit** icon next to the property name DeviceGroup.overlap.

The Modifying Config Property, DeviceGroup.overlap window appears.

Step 3 From the Value drop-down list, choose either **true** or **false**. (The default is true.)

When you disable device group overlap (set to false), existing overlapping device groups are retained and continue to be handled as though overlap were enabled; however, any newly added groups do not allow overlapping, and new devices cannot be added to the existing overlapping groups.

Step 4 Click **Submit**.

Overriding Group Configuration Settings

The WAAS Central Manager GUI provides the following methods to override the current group configuration on a device:

- [Forcing Device Group Settings on All Devices in the Group](#)
- [Selecting Device Group Precedence](#)
- [Overriding the Device Group Settings on a Device](#)

Forcing Device Group Settings on All Devices in the Group

This section has the following topics:

- [Operating Considerations for Force Group Settings](#)
- [Procedure for Forcing Device Group Settings](#)

Operating Considerations for Force Group Settings

The **Device Groups > device-group-name > Force Group Settings** applies all settings configured for a specified device group to all the WAEs/WAAS Express assigned to it.

Note the following uses of Force Group Settings when you register a WAE to the WAAS Central Manager:

- Because all devices in a device group have the same configuration, the configuration you apply at the device group level gets assigned to all the devices in the group.

However, if a device in a device group has local settings that were either configured manually using the CLI or automatically during upgrade, its device settings may be out of sync with the rest of the device group. To remedy this:

- Use Force Group Settings, described in [Procedure for Forcing Device Group Settings](#), to ensure that all devices in the specified group have the same configuration.
- To avoid the need to use Force Group Setting after a device is registered to the Central Manager, restore device's factory default settings *before* registering it to the WAAS Central Manager.

Procedure for Forcing Device Group Settings

To force a device group configuration across all devices in the group, follow these steps:

-
- Step 1** From the WAAS Central Manager menu, choose **Device Groups > device-group-name**.
The Modifying Device Group window appears.
- Step 2** Click the **Force Group Settings** icon in the taskbar.
The WAAS Central Manager GUI displays the following message:
The action will apply all settings configured for this device group to all the WAEs/WAAS Express assigned to it. Do you wish to continue?
- Step 3** To force group settings across all devices in the device group, click **OK**.
- Step 4** Click **Submit**.
-

Selecting Device Group Precedence

When a device belongs to multiple device groups that have conflicting settings, the device automatically inherits the settings from the device group that was most recently changed. For a more detailed description of how a device inherits settings when it belongs to multiple device groups, see [Understanding the Impact of Assigning a Device to Multiple Device Groups](#).

When a configuration conflict occurs, you can edit a device's configuration on a page-by-page basis and select which device group's settings should take precedence.

To select the device group precedence, follow these steps:

-
- Step 1** From the WAAS Central Manager menu, choose **Devices** > *device-name*.
The Device Dashboard window appears.
- Step 2** From the menu bar, choose the configuration option that contains the conflicting settings.
A drop-down list appears in the taskbar at the top of the window. This drop-down list allows you to select the device group that you want this configuration window to inherit settings from. The device group that is currently selected is the device group that has precedence.
- Step 3** From the drop-down list, choose the device group that you want this configuration page to inherit settings from, and click **Submit**.
The configuration window changes to reflect the settings associated with the selected device group.
-

Overriding the Device Group Settings on a Device

The WAAS Central Manager GUI allows you to override the device group settings and specify new settings that are unique to that device.

To override the device group settings on a device, follow these steps:

-
- Step 1** From the WAAS Central Manager menu, choose **Devices** > *device-name*.
The Device Dashboard window appears.
- Step 2** From the menu bar, choose the configuration option that contains the device group settings you want to override.
- Step 3** Click the **Override Group Settings** icon in the taskbar.
The settings in the configuration window are enabled.



Note The Override Group Settings icon only appears on configuration windows that have been modified on the associated device group.

- Step 4** Make the necessary changes to the configuration window, and click **Submit**.
The device is now configured with settings that are different from the device group it belongs to.



Note The Force Settings on all Devices in Group icon appears in the device group view of an overridden configuration window. You can click this icon to reapply the device group settings to all devices in the device group.

- Step 5** To reapply the device groups settings to this configuration window, choose the device group from the drop-down list in the taskbar, and click **Submit**.
-

Understanding the Impact of Assigning a Device to Multiple Device Groups

If a device belongs to multiple device groups, a configuration conflict might occur if the groups are not configured exactly the same. In this case, the device will inherit the settings from the device group that was most recently changed. In some cases, however, a device can retain settings from more than one device group depending on how the changes were implemented.

The following scenario describes how a device can retain settings from multiple device groups:

Action 1: Device A is assigned to Device Group 1 (DG1).

Result: Device A automatically inherits all the configuration settings of DG1.

Action 2: Device A is assigned to Device Group 2 (DG2) so it now belongs to two device groups (DG1 and DG2).

Result: Device A inherits all the settings from DG2, but it remains a member of DG1.

Action 3: The standard time zone setting on DG1 is changed to America New York.

Result: The time zone of Device A changes to America New York, but the device maintains all its other configuration settings from DG2.

In this scenario, Device A's configuration is a hybrid of DG1 and DG2. If you want to specify which device group settings a device should inherit, you can use the override features described in [Overriding Group Configuration Settings](#).

Moving a Device Between Device Groups

To move a WAAS device between two device groups that have different optimization policies, you must reassign the device to a different device group and then force the device group settings on the device.

To move a device between device groups, follow these steps:

-
- Step 1** From the WAAS Central Manager menu, choose **Devices Groups** > *old-device-group-name*.
 - Step 2** Choose *DeviceGroup* > **Assign Devices**.
 - Step 3** Click the green check icon next to the device that you want to reassign. The icon changes to a red arrow pointing left.
 - Step 4** Click **Submit**.
 - Step 5** From the WAAS Central Manager menu, choose **Devices Groups** > *new-device-group-name*.
 - Step 6** Click the blue X icon next to the device that you want to reassign. The icon changes to a green arrow pointing right.
 - Step 7** Click **Submit**.
 - Step 8** Choose **Configure** > **Acceleration** > **Optimization Policies**.
 - Step 9** Click the **Force Settings on all Devices in Group** taskbar icon.
-

Working with Device Locations

The WAAS Central Manager GUI allows you to create locations that you can associate with a WAAS device. You assign a device to a location when you first activate the device. The main purpose of assigning a device to a location is to help you identify a WAAS device by the physical region in which it resides. Locations are different from device groups because devices do not inherit settings from the location to which they belong.

You can view reports that aggregate data from all the devices in a particular location. For more information, see [Location-Level Reports](#) in Chapter 15, “Monitoring Your WAAS Network.”

You assign a device to a location when you activate the device as described in the [Modifying Device Properties](#) in Chapter 10, “Configuring Other System Settings.”

You can work with locations by performing these tasks:

- [Creating Locations](#)
- [Deleting Locations](#)
- [Viewing the Location Tree](#)

Creating Locations

To create a new location or modify an existing one, follow these steps:

-
- Step 1** From the WAAS Central Manager menu, choose **Locations > All Locations**. The Locations window appears.
 - Step 2** In the taskbar, click the **Create New Location** icon.
The Creating New Location window appears.
 - Step 3** In the Name field, enter a location name.
The name can contain letters, numbers, period, hyphen, underscore, and space.
 - Step 4** From the Parent Location drop-down list, choose a parent location (or choose **None**).
A location with no parent is a level 1 location. A location with a level 1 parent becomes a level 2 location, and so forth. The location level is displayed after you choose a parent location (or choose **None**) and click **Submit** to save the configuration.
 - Step 5** (Optional) In the Comments field, enter comments about the location.
 - Step 6** Click **Submit**.
 - Step 7** Modify a location by going to the Locations window and clicking the **Edit** icon next to the name of the location that you want to modify.
 - Step 8** Assign a device to this location. For more information, see [Modifying Device Properties](#) in Chapter 10, “Configuring Other System Settings.”
-

Deleting Locations

You can delete locations as needed, as long as they are not the root locations of activated WAAS devices.

**Note**

If a location has a device assigned to it, you can first assign the device to another location and then delete the original location.

To delete a location, follow these steps:

-
- Step 1** From the WAAS Central Manager menu, choose **Locations** > *location-name*.
The Modifying Location window appears.
- Step 2** In the taskbar, click the **Delete Location** icon. You are asked to confirm your decision to delete the location.
- Step 3** To confirm the action, click **OK**. The location is deleted.
-

Viewing the Location Tree

The location tree represents the network topology you configured when you assigned a parent to each location. The WAAS Central Manager GUI graphically displays the relationships between the locations configured in your WAAS network.

To view the location tree, choose **Locations** > **All Locations**. In the taskbar, click the **Location Trees** button. The location tree shows an expandable list. For each tree node, the corresponding icons show the location or device name.



Configuring AppNav

This chapter describes how to configure Cisco AppNav, which is a hardware and software solution that simplifies network integration of WAN optimization and overcomes challenges with provisioning, visibility, scalability, asymmetry, and high availability.

This chapter includes the following topics:

- [Information About Cisco AppNav](#)
- [Prerequisites for AppNav Deployment](#)
- [Guidelines and Limitations for AppNav Deployment](#)
- [Configuring an AppNav Cluster](#)
- [Monitoring an AppNav Cluster](#)

Information About Cisco AppNav

Cisco AppNav greatly reduces dependency on the intercepting switch or router by distributing traffic among WAAS devices for optimization, by using a powerful class-and-policy mechanism. You can use Cisco WAAS nodes (WNS) to optimize traffic based on sites, or applications, or both.

The AppNav solution has the ability to scale up to available capacity by taking into account WAAS device utilization because it distributes traffic among nodes. Also, the solution provides for high availability of optimization capacity by monitoring node overload and liveliness, and by providing configurable failure and overload policies.

This section includes the following topics:

- [System Components](#)
- [AppNav Controller Deployment Models](#)
- [AppNav Controller Interface Modules](#)
- [AppNav Policy](#)

System Components

The AppNav solution consists of the following components (see [Figure 4-1](#)):

- AppNav Controller (ANC, or AC on the router)—A device that intercepts network traffic and, based on an AppNav policy, distributes that traffic to one or more WAAS nodes (WNS) for optimization. The device can be either of the following:

- A WAAS appliance with a Cisco AppNav Controller Interface Module
- A Cisco router with Cisco IOS XE Release 3.9 (or a later release) running AppNav-XE (known as an AppNav-XE device in this document).

You cannot mix the ANCs on different platforms in the same AppNav cluster.

- AppNav Controller Group (ANCG, or ACG on the router)—A group of AppNav Controllers that together provide the necessary intelligence for handling asymmetric flows and high availability. The ANCG is configured on the ANC. An ANCG can have up to eight WAAS appliance-based ANCs or four AppNav-XE-based ANCs, which must be on the same router platform with the same memory configuration.
- WAAS Node (WN, or SN on the router)—A WAAS optimization engine (WAE or WAVE appliance, NME-WAE or SM-SRE network module, or vWAAS instance, but not a WAAS Express device) that optimizes and accelerates traffic according to the optimization policies configured on the device. You can have up to 32 WNs in the cluster. (In the CLI and on the router, a WAAS node is also known as a service node.)
- WAAS Node Group (WNG, or SNG on the router)—A group of WAAS nodes that services a particular set of traffic flows identified by AppNav policies. The WNG is configured on the ANC. You can have up to 32 WNGs in the cluster. (In the CLI and on the router, a WAAS node group is also known as a service node group.)
- AppNav Cluster—A group of all the ANC and WN devices within a cluster.
- AppNav Context—The topmost entity that groups together one AppNav Controller Group (ANCG), one or more WAAS node groups (WNGs), and an associated AppNav policy. The AppNav context is configured on the ANC. When using a WAAS appliance ANC, there is only one AppNav context. However, when using an AppNav-XE ANC, you can define up to 32 AppNav contexts that are associated with different Virtual Routing and Forwarding (VRF) instances defined on the router.

Figure 4-1 AppNav Solution Components

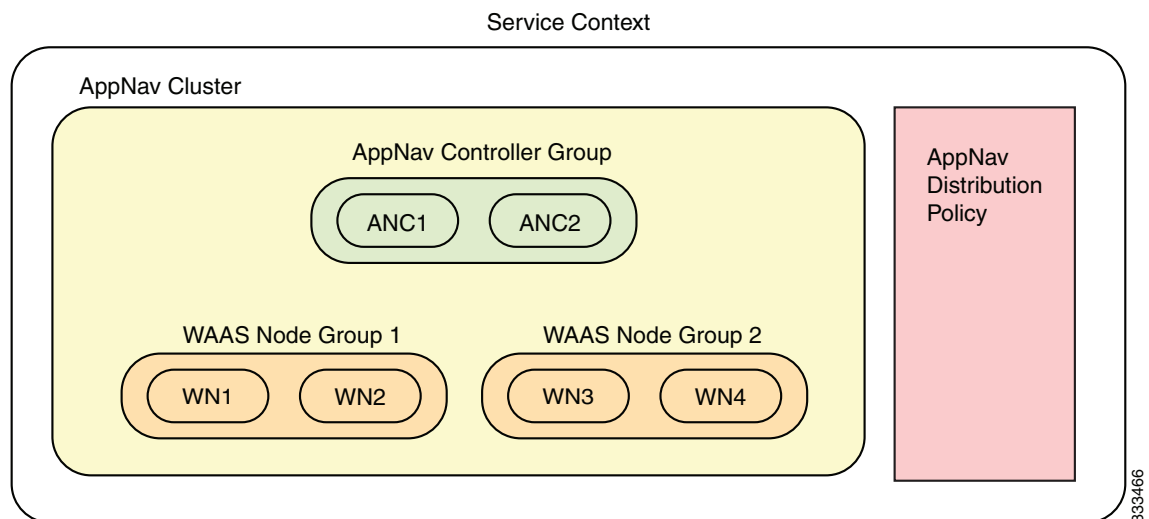

Within a service context, WAAS devices can operate in one of two modes:

- Application accelerator—The device serves only as a WN within the service context. It receives traffic from the ANC, optimizes the traffic, and returns the traffic to the ANC to be delivered to its destination. The WN can be any kind of WAAS device or vWAAS instance.

- AppNav Controller—The device operates as an ANC that intercepts network traffic, and, based on a flow policy, distributes that traffic to one or more WAAS nodes for optimization. Only a WAVE appliance that contains a Cisco AppNav Controller Interface Module, or an AppNav-XE device, can operate as an ANC. A WAAS appliance ANC can also operate as a WAAS node and optimize traffic as part of a WNG.

AppNav Controller Deployment Models

You can deploy WAAS appliance AppNav Controllers in your network in two ways (see [Figure 4-2](#)):

- In-path—The ANC is physically placed between one or more network elements, enabling traffic to traverse a bridge group configured on the device in inline mode.
- Off-path—The ANC works with the network infrastructure to intercept traffic through the Web Cache Communication Protocol (WCCP).

The ANC provides the same features in both in-path and off-path deployments. In either case, only ANCs participate in interception from the switch or router. The ANCs then distribute flows to WNs using a consistent and predictable algorithm that considers configured policies and WAAS node utilization.

[Figure 4-2](#) shows that WAAS Nodes can be attached to either or both switches in the diagrams.

Figure 4-2 WAAS Appliance AppNav Deployment Models

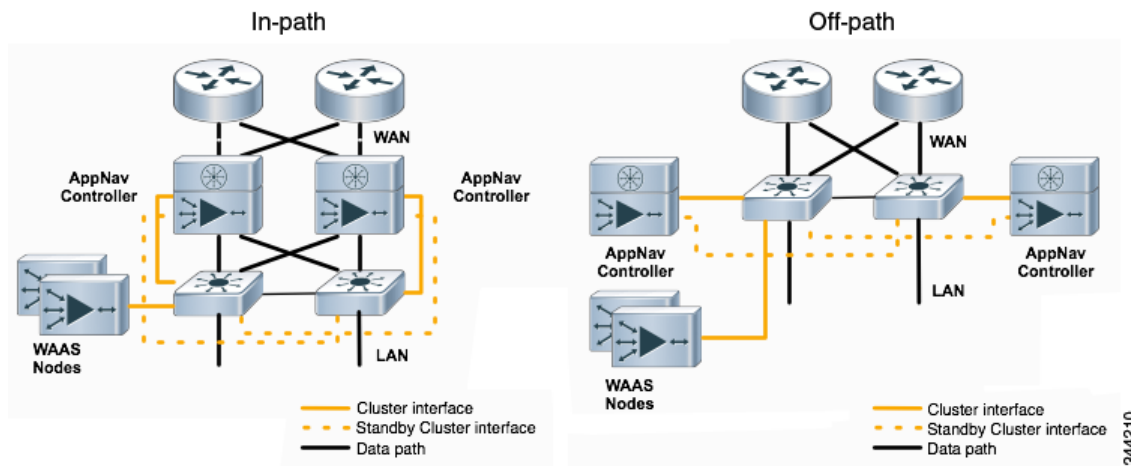

AppNav-XE ANCs have deployment models similar to the in-path diagram shown in [Figure 4-2](#). You can see the specific deployment diagrams in the Central Manager cluster wizard when you choose a platform.

Combination mode

A WAAS device, that has an AppNav IOM card installed, can be configured to perform traffic interception using the AppNav module, and perform optimization as a single device. This is the combination mode as shown in the [Figure 4-3](#):

Figure 4-3 *Devices in combination mode(off-path deployment)*

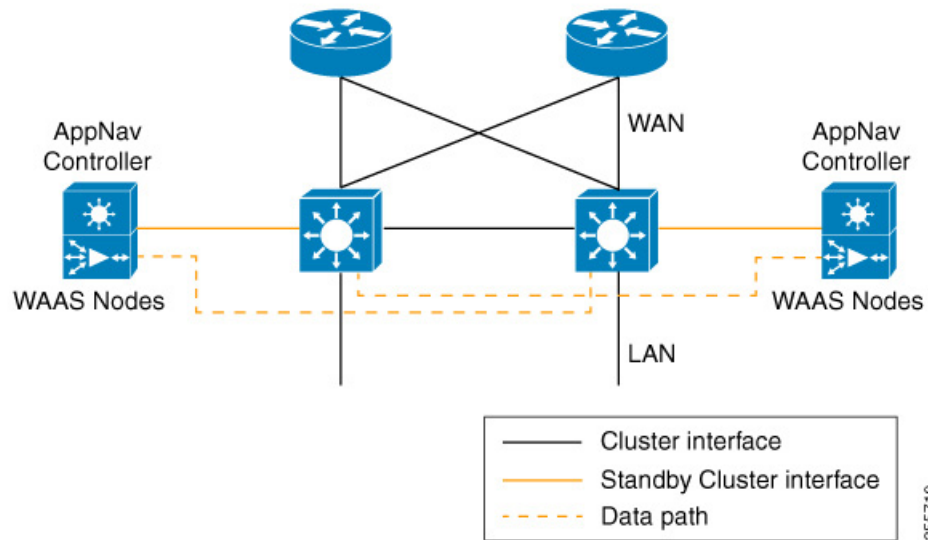

A combination mode deployment is not recommended due the limitation of single point failure as explained below.

Limitation

In a combination deployment, a single AppNav IOM module failure impacts both the AppNav and WAAS functionality. All the traffic to a WAAS node is blocked leading to a loss of active sessions in WAAS. The WAAS node on the combination device becomes unreachable and is removed from the distribution list as shown below. Note that this is applicable for both In-path and Off-path deployments.

Figure 4-4 *Device failure in combination mode(off-path deployment)*

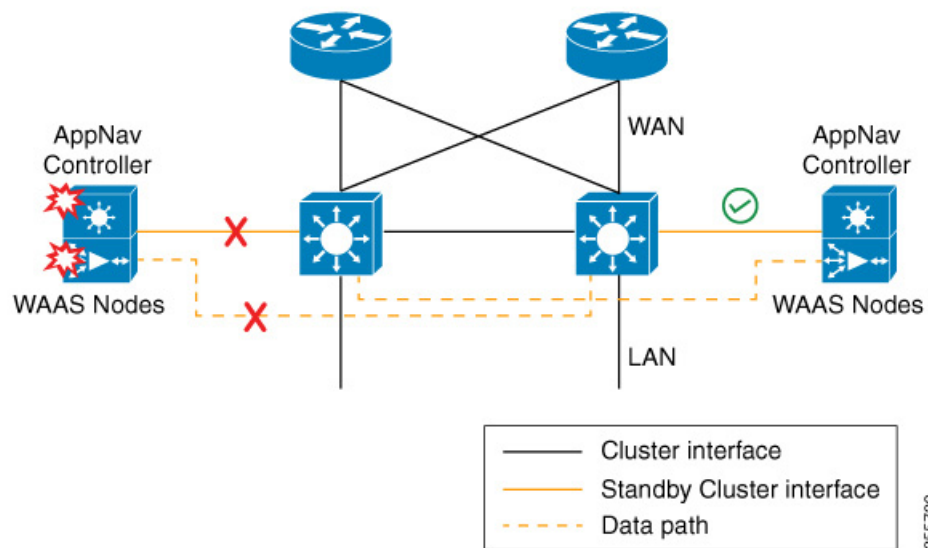
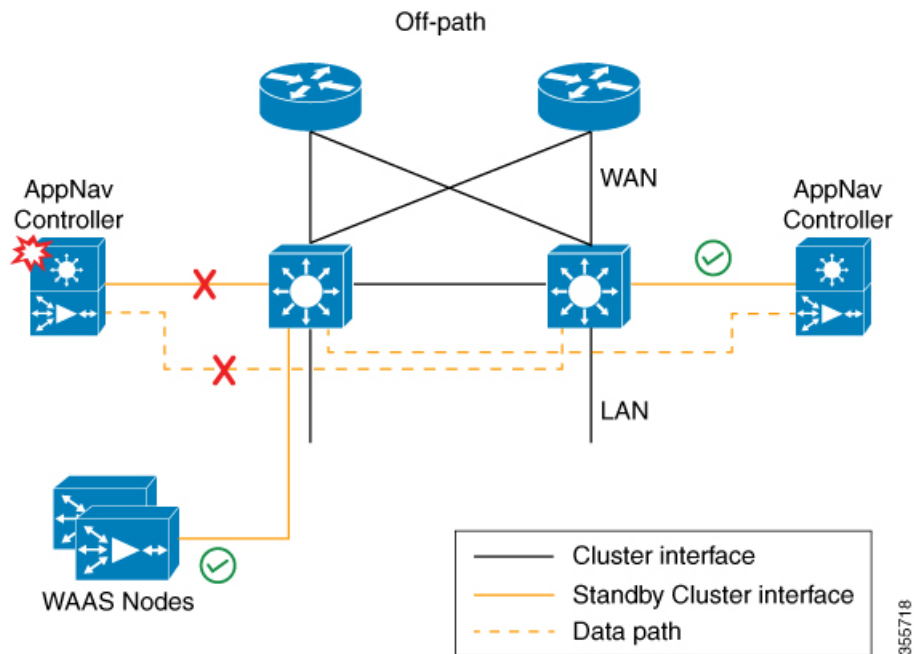

Figure 4-5 AppNav IOM and WAAS nodes in separate devices (off-path deployment)



You may experience some delay during cluster convergence when the AppNav IOM module comes back online. Until then, other devices in the cluster will handle the new flows.

Recommendation

Considering the technical limitation in the combination mode, we strongly recommend to use separate devices for AppNav IOM and WAAS node to avoid a single point failure.

AppNav Controller Interface Modules

A WAAS appliance operating as an ANC requires a Cisco AppNav Controller Interface Module, that is similar to a standard WAVE appliance interface module, but contains additional hardware, including a network processor and high-speed ternary content addressable memory (TCAM), to provide intelligent and accelerated flow handling. The following AppNav Controller Interface Modules are supported:

- 1-GB copper 12-port AppNav Controller Interface Module
- 1-GB SFP 12-port AppNav Controller Interface Module
- 10-GB SFP+ 4-port AppNav Controller Interface Module

AppNav Controller Interface Module interfaces are configured differently to support either in-path or off-path models of deployment:

- In-path—The ANC operates in inline interception mode with at least one inline bridge group configured on the AppNav Controller Interface Module. A bridge group consists of two or more physical or logical (port channel) interfaces.
- Off-path—The ANC operates in WCCP interception mode with one physical or logical (standby or port channel) interface configured with an IP address.

Interfaces on the AppNav Controller Interface Module can have three functions:

- **Interception**—Used to receive traffic intercepted from the network and egress traffic to the network. The interception interface is implied based on the AppNav Controller placement and does not require explicit configuration for this function.
- **Distribution**—Used to distribute traffic to the WNs and receive egressed traffic from the WNs. The distribution interface is explicitly configured as the cluster interface for intracluster traffic and must be assigned an IP address.
- **Management**—A management interface can be optionally and exclusively designated for management traffic and isolated from the normal data path. We recommend that you use one of the appliance's built-in interfaces for management traffic and reserve the high-performance interfaces on the AppNav Controller Interface Module for interception and distribution.

You should use separate interfaces for interception and distribution for best performance, but you can use the same interface for both functions.

AppNav Controller Interface Modules support port channel and standby logical interfaces. A port channel allows you to increase the bandwidth of a link by combining multiple physical interfaces into a single logical interface. A standby interface allows you to designate a backup interface in case of a failure.

Interfaces on the AppNav Controller Interface Module support the following:

- A maximum of seven port channels with up to eight physical interfaces combined into a single port channel group.
- A maximum of five bridge groups configured over the physical or logical interfaces.

Interfaces on the AppNav Controller Interface Module do not support the following:

- Fail-to-wire capability
- Bridge virtual interfaces (BVI)

AppNav Policy

The AppNav policy is a flow distribution policy that allows you to control how ANCs distribute traffic to the available WNs.

The AppNav policy consists of class maps that classify traffic according to one or more match conditions and a policy that contains rules that specify distribution actions to WNGs for each of the classes.

This section includes the following topics:

- [Class Maps](#)
- [Policies](#)
- [Nested Policies](#)
- [Site and Application Affinity](#)
- [Default Policy Behavior](#)

Class Maps

AppNav class maps classify traffic according to one or more of the following match conditions:

- **Peer device ID**—Matches traffic from one peer WAAS device, which could be handling traffic from a single site or a group of sites.

You can use this kind of matching to classify all traffic from a peer device that serves one branch office.

- 3-tuple of source IP, or destination IP, or destination port (matches traffic from a specific application).

For example, you can use this kind of matching to classify all HTTP traffic that uses port 80.

- A mix of one peer device ID and the source IP, or destination IP, or destination port (matches application-specific traffic from one site).

For example, you can use this kind of matching to classify all HTTP traffic that is from a peer device that serves the branch office.

The class-default class map (or APPNAV-class-default on AppNav-XE clusters) is a system-defined default class map that is defined to match any traffic. By default, it is placed in the last rule in each policy to handle traffic that is not matched by other classes.

Policies

An AppNav Controller matches incoming flows to class maps and the policy rules in a policy associate class maps with actions, such as distributing a flow to a particular WNG for optimization. The order in which rules are listed in the policy is important. Starting at the top of the policy, the first rule that matches a flow determines to which WNG it is distributed.

A policy rule can specify four kinds of actions to take on a flow:

- Specify the primary WNG to which to distribute the flow (required).
- Specify a backup WNG for distribution if the primary WNG is unavailable or overloaded (optional; not supported on AppNav-XE clusters).

The primary WNG receives all traffic until all WNs within the group become overloaded (reach 95 percent of the maximum number of connections) or are otherwise unavailable, and then traffic is distributed to the backup WNG. If a WN in the first WNG becomes available, traffic is again distributed there. If all WNs in both the WNGs become overloaded, traffic is passed through unoptimized.

- Monitor the load on the application accelerator that corresponds to the application traffic matched by the class (optional).

If the monitored application accelerator on one WN in a WNG becomes overloaded (reaches 95 percent of its maximum number of connections), the WN is considered overloaded and traffic is directed to another WN in the group. If all WNs become overloaded, traffic is distributed to the backup WNG. This application accelerator monitoring feature is useful for ensuring optimization for critical applications and is recommended for the MAPI and SMB accelerators.

- Specify a nested policy to apply to the flow (optional; not supported on AppNav-XE clusters).

For more information, see [Nested Policies](#).

Within a WNG, flows are distributed among WNs using a hash. If a WN reaches its maximum capacity or becomes unavailable, it is not sent new flows. New flows are sent to other available WNs in the WNG so that they can be optimized successfully. If an unavailable WN later becomes available again, the same client/server pairs will hash to this WN as before.

**Note**

If a WN that is doing MAPI or ICA application acceleration becomes overloaded, flows associated with existing MAPI and ICA sessions continue to be sent to the same WN due to the requirement that the same WN handles these types of flows. New MAPI and ICA flows, however, are distributed to other WNs.

The AppNav policy is specific to each ANC, though typically, all the ANCs in a cluster have the same policy. Each ANC consults its AppNav policy to determine which WNG to use for a given flow. Different ANCs in a cluster can have different AppNav policies, which allows you to customize distribution in certain cases. For example, when a cluster contains ANCs and WNs that are in different locations, it may be more desirable for an ANC to distribute traffic to WNs that are closer to it.

**Note**

On AppNav-XE clusters, the AppNav policy must be the same on all the ANCs in a context.

Nested Policies

A policy rule can specify one nested policy, which allows traffic identified in a class to be subdivided and handled differently. Nested policies provide two advantages:

- They allow another policy to be used as a common subclassification tool.
For example, you can define a policy that contains monitoring actions and apply it as a subpolicy to multiple classes in the primary policy.
- They provide a method of including class maps with both match-any and match-all characteristics into a single subclass.

The nested policy feature is designed for use with site-based classes (matched by peer ID) at the first-level and application-based subclasses (matched by IP address/port) at the second level. Only the first level policy can contain classes that use match peer conditions.

**Note**

AppNav-XE clusters do not support nested policies.

Site and Application Affinity

You can provision a WNG to serve specific peer locations (site affinity) or applications (application affinity) or a combination of the two. Using a WNG for site or application affinity provides the following advantages:

- Provisioning—Localize a class of traffic to achieve control over provisioning and performance monitoring. For example, a business-critical application such as Sharepoint or a business-critical site can be given assured capacity and monitored closely for performance.
- Enhanced application performance—Better compression performance is achieved by limiting data that belongs to a site, to one or a few WNs, which results in better utilization of the Data Redundancy Elimination (DRE) cache.

Figure 4-3 depicts how sites and applications can be associated with node groups. The following WNGs are defined:

- WNG-1—Consists of two WNs that process flows coming only from sites A and B.

- WNG-2—Consists of two WNs that process HTTP and SSL flows from any site. Whether HTTP and SSL flows from Site A and Site B should be processed by WNG-2 or WNG-1 is determined by the order of rules in the policy.
- WNG-3—Consists of two WNs that process MAPI flows coming from any site. Whether MAPI flows from Site A and Site B should be processed by WNG-3 or WNG-1 is determined by the order of rules in the policy.
- WNG-4—Consists of three WNs. The class-default class is applied to this WNG so that all the flows that do not match any other class map are sent to it.

Figure 4-6 Flow Distribution Using Site and Application Affinity

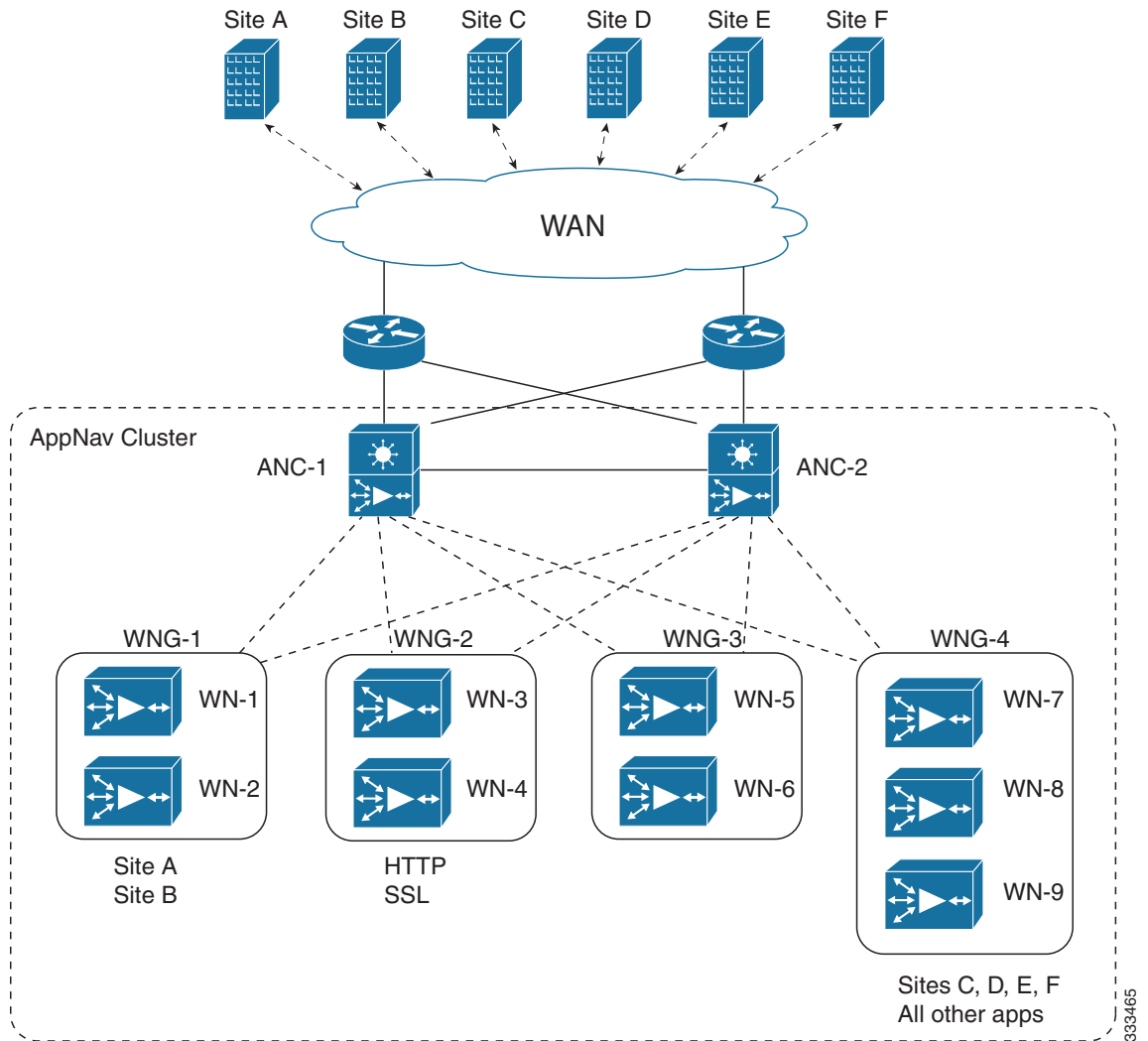

The following sections provide more details about these topics:

- [Site Affinity](#)
- [Application Affinity](#)

Site Affinity

Site affinity provides you with the ability to always send all the traffic from one site to a specific WNG, which allows you to reserve optimization capacity for critical sites and to improve compression performance through better utilization of the DRE cache.

Traffic from any location, not just a single site, can be matched in a class map and associated with a WNG.

You can implement site affinity by configuring a class map that matches the device ID of the WAE in the site. If a site has more than one WAE in a WCCP farm or a serial inline cluster, specify multiple device IDs in the class map. Next, associate the class map with a distribution action to a WNG in a policy rule. You can also identify sites using source IP addresses or subnets in the class map, if you know what IP addresses are used in the site and keep the policy configuration consistent with site IP addresses. However, we recommend that you use peer device IDs when configuring site affinity.



Note

A peer ID-based class map works only for matching flows that carry the WAAS auto discovery TCP options. If you configure a class to match a site peer ID at the data center, the same class does not match flows that originate in the other direction, such as those flows that originate from the data center and go back to the same site. Such flows are usually small in number compared to the site-to-data center flows.

If you want flows in both directions to go to the same WNG, you must configure two class maps: one to match in the site-to-data center direction, typically using the site device ID; and another to match the data center-to-site direction, using destination IP subnets belonging to the site. Both class maps can be configured to distribute traffic to the same WNG. A mesh network is a specific use case where flows can originate in either direction.

If the site WAE is in overload or does not mark the SYN packet with auto discovery options for any other reason, the ANC cannot match it to the peer match class map.

Application Affinity

Application affinity gives you the ability to always send certain application traffic to a specific WNG, which allows you to reserve optimization capacity for different applications depending on business priorities.

In the context of AppNav flow distribution, an application is defined using a three-tuple of source IP, destination IP, and destination TCP port. The actual type of traffic does not matter for flow distribution. For example, you can use separate WNGs for HTTP traffic that is addressed to different destination ports or different server IP addresses. Destination IP and ports are most useful in using application affinity, but having the source IP also helps you to define the traffic of interest.

A small number of protocols, such as FTP, use dynamic destination ports. An FTP server in active mode originates a data connection back to the FTP client using a dynamic destination port. This port is exchanged over the control channel from client to server using the well-defined destination port 21. Consider trying to define a class map for FTP. Because the destination port is not known in advance, you cannot map both control and data connections to the same class. In this case, we recommend that you use the client IP addresses or subnets to match the destination IP addresses for the data connections. You must configure two class maps: one for the control channel, using destination port 21, and another for the data channel, using destination IP addresses. You can configure policy rules so that both class maps distribute traffic to the same WNG.

You can further classify traffic from a site into applications by combining the peer matches with three-tuple matches in a match-all class map, called a Custom class map type in the Central Manager.

Default Policy Behavior

The following default class maps are provided:

- Citrix—Matches traffic for destination port 1494 and 2598
- epmap—Matches traffic for destination port 135
- HTTP—Matches traffic for destination ports 80, 3128, 8000, 8080, and 8088
- HTTPS—Matches traffic for destination port 443
- MAPI—Matches traffic for the MS RPC MAPI application (dynamic port assignment)
- NFS—Matches traffic for destination port 2049
- RTSP—Matches traffic for destination ports 554 and 8554
- class-default or APPNAV-class-default—Matches any TCP traffic. This class map cannot be edited or deleted.

If you use the Central Manager AppNav Cluster wizard to create an AppNav Cluster, the wizard creates a default policy. This policy is assigned by default to all the ANC's in a cluster and contains only the class-default policy rule (APPNAV-class-default on AppNav-XE clusters) that has the following characteristics:

- Matches class-default (any TCP) traffic (APPNAV-class-default on AppNav-XE clusters).
- Distributes class-default traffic to the default WNG, which includes all the WNG's created by the wizard, with no backup WNG specified.
- Contains the waas_app_default nested policy, which provides application monitoring for each of the default class maps. (Not used on AppNav-XE clusters, which do not support nested policies.)

When you use the Central Manager to define a policy rule for any class that uses peer matching or source or destination IP address matching (but not port matching), it automatically adds the waas_app_default policy as a nested policy. The waas_app_default policy is created by the system and monitors all application accelerators, so you do not need to manually add application accelerator monitoring to your policy rules.

If you do not use the Central Manager AppNav Cluster Wizard to create a cluster, there is no default flow distribution. Therefore, if an incoming flow does not match any class in the AppNav policy, it is not distributed to any WNG; instead, it is passed through.

If a WNG is defined, but is not used in any policy rule, it does not receive any flows. If a policy is defined, but not applied to an ANC, it does not take effect.

The default action for a policy rule is none, which is context dependent: in a top-level policy, it means pass-through, and if the policy is nested, it means inherit-the-parent-policy-rule action.

Prerequisites for AppNav Deployment

AppNav deployment has the following prerequisites:

- Each WAAS appliance that is to be used as an AppNav Controller must contain a Cisco AppNav Controller Interface Module.
- Each WAAS appliance AppNav Controller must be configured in appnav-controller device mode.

- If you are using AppNav-XE devices, they must be registered and activated in the Central Manager before the Central Manager can manage them. For more information on registering AppNav-XE devices, see [Managing Cisco IOS Router Devices](#) in Chapter 10, “Configuring Other System Settings.”

**Note**

You can use an AppNav-XE device in a small deployment without a Central Manager by configuring the cluster from the AppNav-XE device CLI. For details, see the corresponding router documentation on www.cisco.com.

Guidelines and Limitations for AppNav Deployment

AppNav deployment has the following configuration guidelines and limitations:

- An AppNav Cluster can contain a maximum of:
 - 8 ANCs if you are using WAAS appliances, or 4 ANCs if you are using AppNav-XE devices
 - 32 WNs, or 64 WNs if you are configuring an AppNav-XE cluster.
 - 32 WNGs
 - A service context if you are using WAAS appliances or 32 service contexts if you are using AppNav-XE devices
- You cannot mix ANCs on different platforms in an AppNav Cluster.
- All the ANCs in an ANCG must have the same set of ANCs and WNGs in their configuration.
- All the WNs in a WNG must have identical optimization policies configured.
- On AppNav-XE devices, all the ANCs in the cluster must have an identical AppNav configuration (class maps, policy maps, VRFs, and so forth). In an AppNav-XE cluster, all AppNav-XE devices must be of the same hardware model.
- AppNav class maps and policies can be configured only at the cluster level, not at the device level, from the Central Manager. At the device level, class maps and policies can only be viewed.
- You can define the following maximum policy entities within a service context on a WAAS appliance cluster:
 - 1024 match conditions
 - 512 AppNav class maps
 - 64 rules per AppNav policy
 - 64 AppNav policies, though only one policy is actively bound to the service context and used for flow distribution on a given ANC
- You can define the following maximum policy entities for an AppNav-XE cluster:
 - 32 match conditions per class map
 - 16384 AppNav class maps
 - 1000 rules per AppNav policy
 - 1024 AppNav policies

- There is no fail-to-wire capability on AppNav Controller Interface Module interfaces configured in bridge groups for inline mode, which would allow traffic to bypass the interface if the device fails or loses power. Therefore, if you are using inline mode, we recommend that you deploy two or more AppNav Controller appliances to provide high availability.
- On AppNav-XE devices, do not use VRF to access the WNs from the ANCs.
- On AppNav-XE devices, do not use a port channel between the ANCs and the WNs because traffic is transmitted over a GRE tunnel and all traffic is switched on one link.
- An AppNav-XE device cannot intercept Overlay Transport Virtualization (OTV) traffic that is configured on the interception interface.
- If you have configured an AppNav-XE device by using the EZConfig CLI utility on the router, you cannot manage the AppNav-XE device with the WAAS Central Manager. To switch between managing the AppNav-XE device with the EZConfig utility on the router and the Central Manager, either delete the AppNav-XE cluster and contexts by using the router CLI or register the devices with the Central Manager and wait for the device configuration to synchronize (about 10 minutes). Then re-create the cluster and contexts by using the Central Manager. To switch from using the Central Manager to manage the AppNav-XE configuration to using the router CLI, delete the cluster and contexts from the Central Manager and then re-create the cluster and contexts by using the router CLI or EZConfig utility.

Configuring an AppNav Cluster

This section contains the following topics:

- [Task Flow for Configuring an AppNav Cluster](#)
- [Configuring WAAS Device Interfaces](#)
- [Creating a New AppNav Cluster with the AppNav Cluster Wizard](#)
- [Configuring AppNav Policies](#)
- [Configuring AppNav Controller ACLs](#)
- [Configuring AppNav Cluster Settings](#)
- [Configuring AppNav Controller Settings](#)
- [Configuring WAAS Node Settings](#)
- [Configuring WAAS Node Group Settings](#)
- [Configuring AppNav Cluster Settings for a WAAS Node](#)
- [Adding and Removing Devices from the AppNav Cluster](#)

Task Flow for Configuring an AppNav Cluster

You must complete the following steps to configure an AppNav Cluster:

1. Install and configure the individual ANC and WN devices with basic network settings. For WAAS appliances, see [Configuring WAAS Device Interfaces](#). For AppNav-XE devices, see the router documentation.

2. Use the Central Manager AppNav Cluster Wizard to create a cluster and configure the interception mode, configure cluster settings, choose cluster devices, configure VRFs (for AppNav-XE), configure traffic interfaces, and configure WCCP settings if you are using WCCP. AppNav-XE. See [Creating a New AppNav Cluster with the AppNav Cluster Wizard](#).
3. (Optional) Configure AppNav class maps. This step is necessary only if you want to customize the default class map configuration. The system adds several default class maps that match traffic corresponding to most of the application accelerators and a class-default class map that matches all traffic. See [Configuring a Class Map on a WAAS Appliance AppNav Cluster](#).
4. (Optional) Configure an AppNav policy. This step is necessary only if you want to customize the default policy. The system adds a default policy that distributes all traffic to the WNG-Default WNG, which is the node group into which all WNs are grouped by default. See [Configuring Rules Within an AppNav Policy](#).
5. (Optional) Configure WAAS node optimization class maps and policy rules. This step is necessary only if you want to customize the default optimization policy that is listed in [Appendix A, “Predefined Optimization Policy.”](#)
6. (Optional) Configure an interception ACL on WAAS appliance ANCs. See [Configuring AppNav Controller ACLs](#).

Configuring WAAS Device Interfaces

Before using the AppNav Cluster wizard to create an AppNav Cluster, connect the WAAS device interfaces and configure the management interfaces. Configuration differs depending on whether management traffic uses a separate interface or shares the traffic handling interface.

This section contains the following topics:

- [Interface Configuration with a Separate Management Interface](#)
- [Interface Configuration with a Shared Management Interface](#)
- [Interface Configuration Considerations](#)

For more information about device interface configuration, see [Chapter 6, “Configuring Network Settings.”](#) For more information about configuring a bridge group for inline interception mode, see the [Configuring Inline Operation on ANCs](#) in Chapter 5, “Configuring Traffic Interception.”

See your Cisco router documentation for information on configuring interfaces on AppNav-XE devices.

Interface Configuration with a Separate Management Interface

If you want management traffic to use a dedicated interface that is separate from the traffic data path, connect and configure the devices as described in this section.

AppNav Controller

-
- | | |
|---------------|---|
| Step 1 | Connect the last AppNav Controller Interface Module port to the switch/router port for the cluster traffic. For example, this port is GigabitEthernet 1/11 on a 12-port module or TenGigabitEthernet 1/3 on a 4-port module. |
| Step 2 | Connect a built-in Ethernet port to the switch/router port for the management interface. |
| Step 3 | For an in-path (inline) deployment, connect the first pair of ports on the AppNav Controller Interface Module, for example, GigabitEthernet 1/0 (LAN) and GigabitEthernet 1/1 (WAN) for bridge 1, to the corresponding switch/router ports. |

If the ANC is connected to a second router for a dual inline deployment, connect the second pair of ports on the AppNav Controller Interface Module, for example, GigabitEthernet 1/2 (LAN) and GigabitEthernet 1/3 (WAN) for bridge 2, to corresponding switch/router ports.

- Step 4** Use the device **setup** command to configure the following settings:
- Configure the device mode as AppNav Controller.
 - Configure the IP address and netmask of the built-in management port.
 - Configure the built-in management port as the primary interface.
 - Configure the other network and basic settings (default gateway, DNS, NTP server, and so forth).
 - Register the device with the Central Manager by entering the Central Manager IP address.
- Step 5** Configure the IP address and netmask of the last AppNav Controller Interface Module port and do not use DHCP. You can also configure these settings through the AppNav Cluster wizard.
-

WAAS Node

- Step 1** Connect a built-in Ethernet port to the switch/router port for management interface.
- Step 2** Use the device **setup** command to configure the following settings:
- Configure the device mode as Application Accelerator.
 - Configure the IP address and netmask of the built-in management port.
 - Configure the built-in management port as the primary interface.
 - Configure the other network and basic settings (default gateway, DNS, NTP server, and so forth).
 - Register the device with the Central Manager by entering the Central Manager IP address.
-

Interface Configuration with a Shared Management Interface

If you want management traffic to use an interface shared by the traffic data path, connect and configure the devices, as described in this section.

AppNav Controller

- Step 1** Connect the last AppNav Controller Interface Module port to the switch/router port for cluster traffic. For example, this port is GigabitEthernet 1/11 on a 12-port module or TenGigabitEthernet 1/3 on a 4-port module.
- Step 2** For an in-path (inline) deployment, connect the first pair of ports on the AppNav Controller Interface Module, for example, GigabitEthernet 1/0 (LAN) and GigabitEthernet 1/1 (WAN) for bridge 1, to corresponding switch/router ports.
- If the ANC is connected to a second router for a dual inline deployment, connect the second pair of ports on the AppNav Controller Interface Module, for example, GigabitEthernet 1/2 (LAN) and GigabitEthernet 1/3 (WAN) for bridge 2, to corresponding switch/router ports.
- Step 3** Use the device **setup** command to configure the following settings:

- Configure the device mode as AppNav Controller.
 - Configure the IP address and netmask of the last AppNav Controller Interface Module port. Do not use DHCP.
 - Configure the last AppNav Controller Interface Module port as the primary interface.
 - Configure the other network and basic settings (default gateway, DNS, NTP server, and so forth).
 - Register the device with the Central Manager by entering the Central Manager IP address.
-

WAAS Node

Step 1 Connect a built-in Ethernet port to the switch/router port for management interface.

Step 2 Use the device **setup** command to configure the following settings:

- Configure the device mode as Application Accelerator.
 - Configure the IP address and netmask of the built-in management port.
 - Configure the built-in management port as the primary interface.
 - Configure the other network and basic settings (default gateway, DNS, NTP server, and so forth).
 - Register the device with the Central Manager by entering the Central Manager IP address.
-

Interface Configuration Considerations

The following guidelines concern WAAS device interface configuration:

- On an ANC, the intercepted traffic must go through an interface on the AppNav Controller Interface Module.
- On an ANC that also serves as a WN, the cluster interface is the same as the interception interface.
- On a WN, cluster traffic can be handled on any interface, either built-in or on an interface module.
- To simplify AppNav deployment, the AppNav Cluster Wizard uses the following conventions for configuring the AppNav Controller Interface Module ports on an ANC:
 - The default port for cluster traffic is the last port on the module, for example, GigabitEthernet 1/11 on a 12-port module or TenGigabitEthernet 1/3 on a 4-port module.
 - For an in-path (inline) deployment, the default interception bridge is the first pair of ports on the module, for example, GigabitEthernet 1/0 (LAN) and GigabitEthernet 1/1 (WAN) for bridge 1. If the ANC is connected to a second router for a dual inline deployment, the default second interception bridge is the second pair of ports on the module, for example, GigabitEthernet 1/2 (LAN) and GigabitEthernet 1/3 (WAN) for bridge 2.

The AppNav Cluster Wizard uses four predefined deployment models to help simplify configuration on a WAAS appliance. Each deployment model expects interfaces to be connected and configured in a particular way, except for the Custom option, which allows you to configure interfaces in any way. Before you run the wizard with one of the four predefined models, the required interfaces must be in either of these states:

- Not configured with an IP address and netmask and not used as part of another logical interface. (However, the last port on the AppNav Controller Interface Module can be configured with an IP address because it is the default port for cluster traffic.)

The wizard configures all required traffic interface settings.

- Configured as expected by the wizard according to the following predefined deployment model expectations:

Single AppNav Controller WCCP Interception

With a 12-port AppNav Controller Interface Module:

- Port channel 1—Contains ports GigabitEthernet 1/10 and 1/11
- Cluster interface—Port channel 1

With a 4-port AppNav Controller Interface Module:

- Cluster interface—GigabitEthernet 1/3

Dual AppNav Controllers WCCP Interception

With a 12-port AppNav Controller Interface Module:

- Port channel 1—Contains ports GigabitEthernet 1/10 and 1/11
- Port channel 2—Contains ports GigabitEthernet 1/8 and 1/9
- Standby group 1—Contains interfaces Port channel 1 (primary) and Port channel 2
- Cluster interface—Standby Group 1

With a 4-port AppNav Controller Interface Module:

- Standby group 1—Contains ports GigabitEthernet 1/2 and 1/3 (primary)
- Cluster interface—Standby Group 1

Single AppNav Controller Inline Interception

- Interception bridge 1—Contains ports GigabitEthernet 1/0 (LAN) and 1/1 (WAN)
- Cluster interface—GigabitEthernet 1/11

Dual AppNav Controllers Inline Interception

- Interception bridge 1—Contains ports GigabitEthernet 1/0 (LAN) and 1/1 (WAN)
- Interception bridge 2—Contains ports GigabitEthernet 1/2 (LAN) and 1/3 (WAN)
- Standby group 1—Contains ports GigabitEthernet 1/10 and 1/11 (primary)
- Cluster interface—Standby Group 1

Creating a New AppNav Cluster with the AppNav Cluster Wizard

See the topic for the type of AppNav Cluster you want to create:

- [Creating a WAAS Appliance AppNav Cluster](#)
- [Prerequisites for Creating an AppNav-XE Cluster](#)

Creating a WAAS Appliance AppNav Cluster

Prerequisites

- Set up the individual ANC and WN devices as described in [Configuring WAAS Device Interfaces](#).
- Ensure that all ANCs are configured for AppNav Controller device mode. If you need to change the device mode, see [Changing Device Mode](#) in Chapter 2, “Planning Your WAAS Network.”
- Use the Central Manager to configure basic settings for all devices such as NTP server, AAA, logging, and so on.

Detailed Steps

To create a new AppNav Cluster using the AppNav Cluster wizard, follow these steps:

-
- Step 1** From the WAAS Central Manager menu, choose **AppNav Clusters > All AppNav Clusters**. The Manage AppNav Clusters window appears.
- Step 2** Click the **AppNav Cluster Wizard** icon in the taskbar of the Manage AppNav Clusters area. The AppNav Cluster Wizard window appears.
- Step 3** From the AppNav platform drop-down list, choose WAVE Appliance.
- Step 4** From the Deployment model drop-down list, choose one of the following deployment models that matches your deployment:
- Single AppNav Controller WCCP interception
 - Dual AppNav Controllers WCCP interception
 - Single AppNav Controller Inline interception
 - Dual AppNav Controllers Inline interception
 - Custom—For a deployment that does not match one of the above choices.
- Click **Next**.
- Step 5** (Optional) If you chose the Custom deployment model, from the Interception method drop-down list, choose the **WCCP** or **Inline interception** method and click **Next**.
- Step 6** Define the cluster settings by entering the following information:
- In the Name field, enter a name for the cluster. Use only letters, numbers, hyphen, and underscore, up to a maximum of 32 characters and beginning with a letter.
 - (Optional) In the Description field, enter a description of the cluster. Use only letters and numbers, up to a maximum of 200 characters.
 - Check the **Disable Distribution** check box if you want make the cluster operate in monitoring mode, otherwise, it is activated when the wizard finishes. In monitoring mode, all traffic is passed through instead of being distributed to WNs.
- Step 7** Click **Next**.
- Step 8** Choose the ANC and WN devices that you want to be part of the cluster:
- a. Choose up to eight ANCs in the AppNav Controller device list by clicking the check box next to the device names. You can use the filter settings in the taskbar to filter the device list.

- b. (Optional) To enable optimization on the ANC devices, check the **Enable WAN optimization on selected AppNav Controller(s)** check box (it may be enabled or disabled by default, depending on the deployment model you chose).
- c. Choose up to 32 WNs in the WAAS Nodes device list by clicking the check box next to the device names. You can use the filter settings in the taskbar to filter the device list.

If there are devices that are ineligible to join the cluster, click **Show Ineligible Devices** to see them and the reasons why they are ineligible. You can use the filter settings to filter the list.

Step 9 Click **Next**.

Step 10 Verify the cluster interface, IP address, and netmask for each device in the cluster. The wizard automatically selects recommended cluster interfaces that should be configured. To edit the IP address and netmask settings for a device, choose the device and click the **Edit** taskbar icon.



Note This screen does not appear if you are configuring a custom cluster.

Step 11 Click **Finish** if you are using inline interception (and you are done) or click **Next** if you are using WCCP interception (and continue with the following steps for WCCP).

Step 12 (Optional) Configure the WCCP settings for the ANC. This screen does not appear if you are configuring an inline cluster.

For details about configuring WCCP, see [Configuring WCCP on WAEs](#) in Chapter 5, “Configuring Traffic Interception.”

- a. Ensure that the **Enable WCCP Service** check box is checked if you want to enable WCCP. This item appears only if you are defining a custom cluster.
- b. Verify the single WCCP service ID of 61 (default), or change it if desired.
Configure only this single WCCP service on both the ingress and egress ports of the router doing WCCP redirection to this ANC.
- c. (Optional) If you want to enable two WCCP services, uncheck the **Enable Single Service Mode** check box (it is checked by default because two WCCP services are not required). The automatically assigned second service ID number is shown in the Service ID2 field.
- d. From the Redirect Method drop-down list, choose the **WCCP L2** or **WCCP GRE** redirect method. For details on the redirect method, see [Configuring or Viewing the WCCP Settings on ANCs](#) in Chapter 5, “Configuring Traffic Interception.” This item appears only if you are defining a custom cluster.
- e. (Optional) If you do not want to use the default gateway defined on the device, uncheck the **Use Default Gateway as WCCP Router** check box. Enter the address of one or more WCCP routers, separated by commas, in the WCCP Routers field.
- f. Click **Advanced WCCP Settings** to configure additional settings, as needed. For more information on these fields, see [Configuring or Viewing the WCCP Settings on ANCs](#) in Chapter 5, “Configuring Traffic Interception.” This item appears only if you are defining a custom cluster.

Step 13 Click **Next**. If you are configuring multiple ANCs, a similar screen is shown for each ANC.

- Step 14** Configure the interception and cluster interface settings for each device. The Cluster Interface wizard only appears if you are defining a custom cluster, with one screen for each device in the cluster:
- Configure individual interception interfaces, port channels, standby interfaces, and bridge interfaces (for inline only), as needed, on the device by using the graphical interface wizard. If you are configuring an inline ANC, you must define a bridge interface with two physical or port-channel interfaces (or one of each) for interception. For details on how to use the wizard, see [Configuring Interfaces with the Graphical Interface Wizard](#).
 - From the Cluster Interface drop-down list, choose the interface to be used for intracluster traffic.
- Step 15** Click **Next**. If you are configuring multiple devices, a similar screen is shown for each device.
- Step 16** Click **Finish** to save the cluster configuration.
-

By default, the Cluster Interface wizard assigns all the WNs to a default WNG named WNG-Default. You can create additional WNGs, as described in [Adding a New WAAS Node to the Cluster](#). You can reassign WNs to different WNGs, as described in [Configuring WAAS Node Settings](#).

After you create an AppNav Cluster, it is shown in the Manage AppNav Clusters list. For details on monitoring the cluster, see [Monitoring an AppNav Cluster](#).

Prerequisites for Creating an AppNav-XE Cluster

- Set up the individual ANC and WN devices. Configure WN device interfaces, as described in [Configuring WAAS Device Interfaces](#). Configure ANC device interfaces, as described in the router documentation on www.cisco.com.
- Configure any desired VRF instances on the ANC routers.
- Register all AppNav-XE devices with the Central Manager and ensure they are activated in the Central Manager. For more information on registering AppNav-XE devices, see [Managing Cisco IOS Router Devices](#) in Chapter 10, “Configuring Other System Settings.”

Detailed Steps

To create a new AppNav-XE cluster by using the wizard, follow these steps:

- Step 1** From the WAAS Central Manager menu, choose **AppNav Clusters > All AppNav Clusters**. The Manage AppNav Clusters window appears.
- Step 2** Click the **AppNav Cluster Wizard** icon in the taskbar of the Manage AppNav Clusters area. The Cluster Wizard window appears.
- Step 3** From the AppNav platform drop-down list, choose one of the following AppNav-XE platforms to use for your deployment. All ANCs must use the same platform type with identical memory configurations.
- ASR 1000 Series—AppNav-XE on the Cisco ASR 1000 Series Aggregation Services Router
 - CSR 1000V Series—AppNav-XE on the Cisco Cloud Services Router 1000V Series
 - ISR 4451X—AppNav-XE on the Cisco 4451-X Integrated Services Router
- Step 4** Click **Next**.
- Step 5** Define the cluster settings by entering the following information:
- In the Cluster Name field, enter a name for the cluster. Use only letters, numbers, hyphen, and underscore. A maximum of 32 characters, beginning with a letter, can be entered.

- (Optional) In the Description field, enter a description of the cluster. Use only letters and numbers. A maximum of 200 characters can be entered.
- (Optional) From the WAAS Cluster ID drop-down list, choose a cluster ID that is unique for this cluster in your WAAS network. Only unused cluster IDs are shown.

Click **Next**.

- Step 6** Choose the ANC and WN devices that you want to be part of the cluster:
- a. Choose up to four AppNav-XE devices of the same platform type in the AppNav Controller device list by clicking the check box next to the device names. You can use the filter settings in the taskbar to filter the device list.
 - b. Choose up to 64 WNs in the WAAS Nodes device list by clicking the check box next to the device names. You can use the filter settings in the taskbar to filter the device list.
- If there are devices that are ineligible to join the cluster, click **Show Ineligible Devices** to see them and the reasons why they are ineligible. You can use the filter settings to filter the list.
- Step 7** Click **Next**.
- Step 8** Choose the VRF instances to associate with the service context by checking the box next to each VRF instance that you want to use. If you choose the VRF default, you cannot choose other VRFs. If you choose multiple VRFs, they must not have overlapping source IP addresses. Only VRFs that are available on all the ANCs are listed in the top table. Ineligible VRFs are listed in the lower table.
- Step 9** Click **Next**.
- Step 10** Configure the interception and cluster interface settings for each ANC device in the cluster:
- a. Choose the WAN interfaces on which traffic interception is to be enabled. Interfaces must already be configured on the AppNav-XE devices and only those on which service insertion can be enabled are listed.
 - b. Choose the local interface to be used for intra-cluster traffic.
- Step 11** Click **Next**. If you are configuring multiple ANCs, a similar screen is shown for each device.
- Step 12** Configure the cluster interface settings for each WN device in the cluster. The Cluster Interface wizard appears, with one screen for each WN in the cluster:
- a. Configure individual interfaces, as needed, on the device by using the graphical interface wizard. For details on how to use the wizard, see [Configuring Interfaces with the Graphical Interface Wizard](#).
 - b. From the Cluster Interface drop-down list, choose the interface to be used for intra-cluster traffic.
- Step 13** Click **Next**. If you are configuring multiple WNs, a similar screen is shown for each device.
- Step 14** Click **Finish** to save the cluster configuration.

By default, the wizard assigns all the WNs to a default WNG named WNG-Default. You can create additional WNGs, as described in [Adding a New WAAS Node to the Cluster](#). You can reassign WNs to different WNGs, as described in [Configuring WAAS Node Settings](#).

To begin traffic optimization with AppNav-XE, enable WAAS service insertion on the AppNav-XE device interfaces on which you chose to intercept traffic. For more information, see [Enabling WAAS Service Insertion on AppNav-XE Device Interfaces](#) in Chapter 6, “Configuring Network Settings.”

After you create an AppNav Cluster, it is shown in the Manage AppNav Clusters list. For details on monitoring the cluster, see the [Monitoring an AppNav Cluster](#).

Configuring Interfaces with the Graphical Interface Wizard

You can easily configure interfaces on the AppNav Controller Interface Modules that are installed in devices that are a part of an AppNav Cluster by using the graphical interface wizard (see [Figure 4-4](#)). Additionally, you can configure WN interfaces.

Figure 4-7 Graphical Interface Wizard

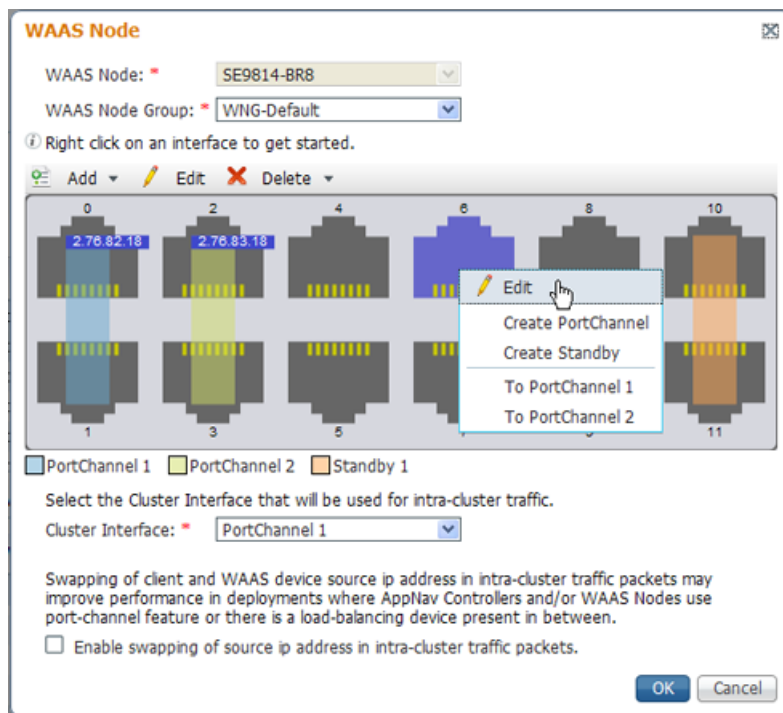

Note

The graphical interface wizard is not used to configure interfaces on AppNav-XE ANCs.

The graphical interface wizard appears when you are editing the settings for a WN or ANC in the AppNav Cluster context.



Note

The top two fields, WAAS Node and WAAS Node Group, do not appear when configuring ANC interfaces.

In the graphical interface view, hover your mouse over a physical or logical interface to see its identifier, for example, GigabitEthernet 1/0. Port channels, bridge groups, and standby groups are indicated by colored blocks or dotted outlines. The IP address of each configured physical or logical interface is shown with a small blue highlight. The legend below the table indicates port channel, bridge group, and standby interfaces.

Right-click an interface to choose, from the following options (available actions are dependent on the device and cluster type):

- Edit—Displays a pane where you can edit the interface description, IP address, netmask, and shutdown status.

- Create PortChannel—Creates a new port channel with this interface. This choice displays a pane where you can configure the port channel number, description, IP address, netmask, and shutdown status.
- Create Bridge—To create a new bridge group with this interface. This choice displays a pane where you can configure the bridge group number and description and enable link state propagation. This choice appears only when configuring a device for inline interception. A bridge interface consists of two physical or port-channel interfaces (or one of each)
- Create Standby—Creates a new standby group with this interface. This choice displays a pane where you can configure the standby group number, description, IP address, netmask, and shutdown status.
- To PortChannel n —Adds this interface to an existing port channel, where n is the port channel number.
- To Standby n —Adds this interface to an existing standby group, where n is the standby group number.
- To Bridge n —Adds this interface to an existing bridge group, where n is the bridge group number.
- For standby interfaces (right-click within the standby interface group indicator):
 - Edit—Edits the standby group settings, such as the description, IP address, netmask, primary interface, and shutdown status.
 - Delete Standby n —Deletes the standby group.
- For port channel interfaces (right-click within the port channel indicator):
 - Edit—To edit the port channel settings such as the port channel number, description, IP address, netmask, and shutdown status.
 - Remove from Standby n —To remove the port channel from standby group n .
 - Delete PortChannel n —To delete the port channel.
- For bridge group interfaces (right-click within the bridge group indicator):
 - Edit—Edits the bridge group settings, such as the bridge group number, description, and link state propagation status.
 - Delete Bridge n —Deletes the standby group.

To select an interface:

- Individual interface—Click-and-selection is indicated by a blue color.
- Standby group—Click the colored or dotted line indicator (the selection is indicated by a thick dotted blue outline around all the interfaces in the standby group).
- Port channel or bridge group—Click the colored indicator (the selection is indicated by a thick dotted blue outline around all the interfaces in the port channel or bridge group).

You can also perform actions by selecting an interface and clicking the following taskbar icons:

- Add (choices differ depending on the selected entity):
 - Create PortChannel—Creates a new port channel with this interface.
 - Create Bridge—Creates a new bridge group with this interface.
 - Create Standby—Creates a new standby group with this interface.
 - To PortChannel n —Adds this interface to an existing port channel, where n is the port channel number.
 - To Standby n —Adds this interface to an existing port channel, where n is the port channel number.

- Edit—Edits the selected interface.
- Delete (choices differ depending on the selected entity):
 - Remove from Standby *n*—Removes the port channel from standby group *n*.
 - Delete PortChannel *n*—Deletes the port channel.
 - Delete Standby *n*—Deletes the standby group.
 - Delete Bridge *n*—Deletes the bridge group.

From the Cluster Interface drop-down list, select the interface to be used for intra-cluster traffic, between the ANC and WNs.

To enable swapping of client and WAAS device source IP address fields in intra-cluster traffic, check the **Enable swapping of source IP address in intra-cluster traffic** check box. Consider enabling this option if you are using a port channel for the cluster interface, or there is a load-balancing device between the ANC and WN. This option can improve load balancing of traffic that the ANC distributes to WNs for optimization because it load balances based on the client IP address rather than the ANC IP address. (For traffic from the server to the client, it swaps the server IP address with the ANC IP address.) This option is not available for AppNav-XE clusters.

**Note**

If you are using WCCP, the WCCP control messages must pass through the ANC interface that receives intercepted traffic from the routers. If WCCP control messages are routed to the ANC management interface, the cluster does not operate.

Configuring AppNav Policies

This section contains the following topics:

- [Configuring a Class Map on a WAAS Appliance AppNav Cluster](#)
- [Configuring Rules Within an AppNav Policy](#)
- [Managing AppNav Policies](#)
- [Configuring WAAS Node Optimization Policy](#)

Configuring a Class Map on a WAAS Appliance AppNav Cluster

The following topics are described here:

- [Configuring a WAAS Appliance AppNav Class Map](#)
- [Configuring a Class Map on an AppNav-XE Cluster](#)

Configuring a WAAS Appliance AppNav Class Map

To configure a class map on a WAAS appliance AppNav cluster, follow these steps:

-
- Step 1** From the WAAS Central Manager menu, choose **AppNav Clusters** > *cluster-name*.
- Step 2** Choose **Configure** > **AppNav Cluster** > **AppNav Class-Map**.

The AppNav Class-Maps window appears, listing the existing class maps.

From this window, you can perform the following tasks:

- From the Show drop-down list, filter the class map list as needed. You can use Quick Filter or Show All Class Maps.
- Edit a class map by selecting it and clicking the **Edit** taskbar icon.
- Delete one or more class maps by selecting them and clicking the **Delete** taskbar icon.
- Add a new class map, as described in the steps that follow.

Step 3 Click the **Add Class-Map** taskbar icon.

Step 4 In the Name field enter a name for the class map, that can contain a maximum of 40 alphanumeric characters and an underscore.

Step 5 (Optional) In the Description field enter a description for the class map, that can contain a maximum of 200 alphanumeric characters, underscore, and a space.

Step 6 From the Type drop-down list, choose the class map type:

- **Application**—Matches traffic for a particular application based on source or destination IP addresses or ports, or all of them, or the Microsoft RPC application identifier (for applications that use dynamic port allocation). If you choose this option, continue with [Step 7](#).
- **Site**—Matches traffic from particular WAAS peer devices, for site affinity. If you choose this option, continue with [Step 8](#).
- **Custom**—Mixes application and site affinity. Matches traffic for a particular application from one specific peer WAAS device. If you choose this option, continue with [Step 9](#).
- **Any TCP**—Matches any TCP traffic as a catch-all classifier. If you choose this type, there are no other fields to set. Click **OK** to finish and return to the class maps list.



Note The match conditions shown in the lower part of the pane change depending on the class map type.

Step 7 (Optional) For an Application class map type, enter one or more match conditions. You can perform the following tasks in this pane:

- Edit a match condition by selecting it and clicking the **Edit** taskbar icon.
- Delete one or more match conditions by selecting them and clicking the **Delete** taskbar icon.
- Add a new match condition, as described in the steps that follow.

Figure 4-8 AppNav Class Map Dialog Box

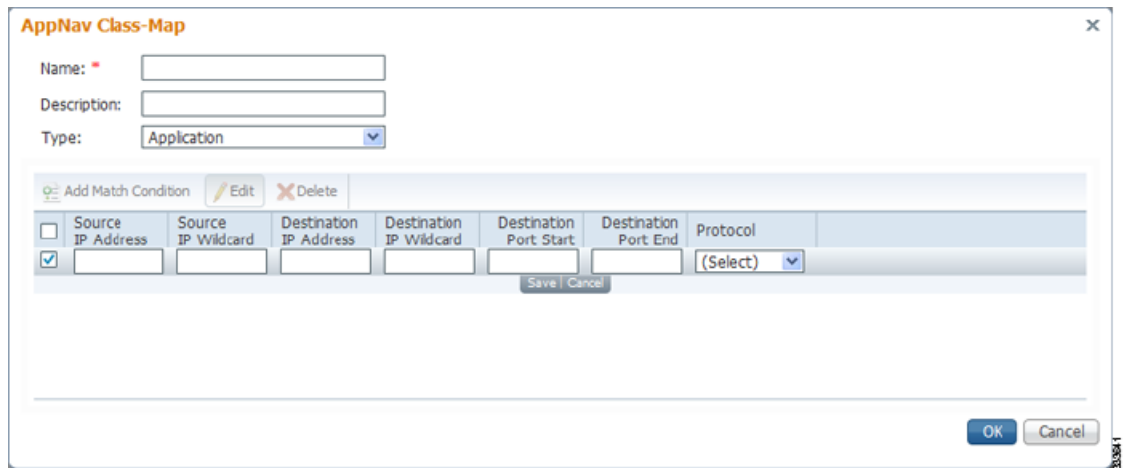

- a. Click the **Add Match Condition** taskbar icon.
- b. Enter values in one or more fields to create a condition for a specific type of traffic. For example, to match all the traffic going to ports 5405 to 5407, enter **5405** in the Destination Port Start field and **5407** in the Destination Port End field. You can use the IP address wildcard fields to specify a range of IP addresses using a wildcard subnet mask in dotted decimal notation, for example, 0.0.0.255 for /24.
- c. To match Microsoft RPC traffic that uses dynamic port allocation, choose the RPC application identifier from the Protocol drop-down list. For example, to match Microsoft Exchange Server traffic that uses the MAPI protocol, choose **mapi**.
- d. Click **Save** to save the match condition.
- e. Add additional match conditions, as needed. Click **OK** to save the class map and return to the class maps list. If any of the conditions is matched, the class is considered matched.

Step 8 (Optional) For a Site class map type, select one or more peer devices. Perform the following steps to create the class map:

Figure 4-9 AppNav Class Map Dialog Box with Add Match Condition List

The screenshot shows the 'AppNav Class-Map' dialog box. It has fields for 'Name', 'Description', and 'Type' (set to 'Site'). Below these is a table of devices with columns for 'Device Name', 'IP Address', 'Device ID', and 'Location'. A 'Show' dropdown is set to 'All'. At the bottom are 'OK' and 'Cancel' buttons.

<input type="checkbox"/>	Device Name	IP Address	Device ID	Location
<input type="checkbox"/>	BLR-WAAS-1	69.32.2.21	11:11:11:11:22:21	Bangalore
<input type="checkbox"/>	BLR-WAAS-2	69.32.2.22	11:11:11:11:22:22	Bangalore
<input type="checkbox"/>	BLR-WAAS-3	69.32.2.23	11:11:11:11:22:23	Bangalore
<input type="checkbox"/>	BLR-WAAS-4	69.32.2.24	11:11:11:11:22:24	Bangalore
<input type="checkbox"/>	BLR-WAAS-5	69.32.2.25	11:11:11:11:22:25	Bangalore
<input type="checkbox"/>	BLR-WAAS-6	69.32.2.26	11:11:11:11:22:26	Bangalore

- From the Show drop-down list, filter the device list as required, quick filter, show all devices, or show all assigned devices.
- Check the box next to each device you want to match traffic from. Check the box next to the column title to select all the devices and uncheck it to deselect all the devices. If any of the selected devices is matched, the class is considered matched.
- Click **OK** to save the class map and return to the class maps list.

Step 9 (Optional) For a Custom class map type, enter a match condition based on IP address/port or Microsoft RPC application ID, and choose a WAAS peer device. All the specified matching criteria must be met for the class to be considered matched. Perform the following steps to create the class map.

Figure 4-10 AppNav Class Map with Match Conditions

The screenshot shows the 'AppNav Class-Map' dialog box with 'Type' set to 'Custom'. It includes fields for 'Name', 'Description', 'Source IP Address', 'Destination IP Address', 'Destination Port Start', 'Protocol', 'Remote Device', 'Source IP Wildcard', 'Destination IP Wildcard', and 'Destination Port End'. 'OK' and 'Cancel' buttons are at the bottom.

- Enter values in one or more IP address or port fields, or both, to create a condition for a specific type of traffic. For example, to match all traffic going to ports 5405 to 5407, enter **5405** in the Destination Port Start field and **5407** in the Destination Port End field. You can use the IP address wildcard fields to specify a range of IP addresses using a wildcard subnet mask in dotted decimal notation (such as 0.0.0.255 for /24).

**Note**

We strongly recommend that you use the WAAS Central Manager GUI to centrally configure class maps for your WAAS devices. However, there is one exception to this recommendation. Use the CLI to create an AppNav class map with a Type of Application or Custom, and whose source or destination address has one of the following: an IP address ending in “0.0.0” or a non-Class A IP address ending in “0.0”.

- b. (Optional) To match Microsoft RPC traffic that uses dynamic port allocation, choose the RPC application identifier from the Protocol drop-down list. For example, to match Microsoft Exchange Server traffic that uses the MAPI protocol, choose **mapi**.
- c. Choose a WAAS peer device from the Remote Device drop-down list.
- d. Click **OK** to save the class map and return to the class maps configuration window.

Configuring a Class Map on an AppNav-XE Cluster

To configure a class map on an AppNav-XE cluster, follow these steps:

Step 1 From the WAAS Central Manager menu, choose **AppNav Clusters > cluster-name**.

Step 2 Choose **Configure > AppNav Cluster > AppNav Class-Map**.

The AppNav Class-Maps window appears, listing the existing class maps.

From this window, you can perform the following tasks:

- From the Show drop-down list, choose a filter setting to filter the class map list as needed. You can use Quick Filter or Show All Class Maps.
- Edit a class map by selecting it and clicking the **Edit** taskbar icon.
- Delete one or more class maps by selecting them and clicking the **Delete** taskbar icon.
- Add a new class map as described in the steps that follow.

Step 3 Click the **Add Class-Map** taskbar icon.

Figure 4-11 AppNav Class Map with Match Condition List

Action	Prot...	Source IP Address	Source Mask	Source Operator	Source Port	Destination IP Address	Destination Mask	Destination Operator	Destination Port	Protocol	Remote Devices
No data available											

Step 4 In the Name field, enter a name for the class map. A maximum of 221 characters, excluding space or question mark (?), can be entered.

- Step 5** (Optional) In the Description field, enter a description for the class map. A maximum of 200 characters, excluding a question mark (?), can be entered.
- Step 6** From the Match Type radio buttons, choose **match-any** or **match-all**. Match-any means that if any one of the match conditions is matched, the class is considered matched. Match-all means that all the match conditions must be matched for the class to be matched.
- Step 7** Click the **Add Match Condition** taskbar icon.
The Match Condition pane appears.
- Step 8** From the Match Condition drop-down list, choose the type of match condition you want to create:
- Source/Destination IP—Matches traffic for a particular application based on an access list of source and/or destination IP addresses and/or ports. Continue with [Step 9](#).
 - Protocol—Matches traffic for a particular Microsoft RPC application identifier (for applications that use dynamic port allocation). Continue with [Step 10](#).
 - Peer—Matches traffic from particular WAAS peer devices, for site affinity. Continue with [Step 11](#).
- The match conditions shown in the lower part of the pane change depending on the condition type.
- Step 9** (Optional) For a Source/Destination IP match condition type, enter one or more access control entries (ACEs). You can perform the following tasks in this pane:
- Edit an ACE by selecting it and clicking the **Edit** taskbar icon.
 - Delete one or more ACEs by selecting them and clicking the **Delete** taskbar icon.
 - Move one or more selected ACEs to a new position by clicking the **Move To** taskbar icon. After moving the ACEs, click **Save Moved Rows** to save the change.
 - Move one or more selected ACEs up or down one position by clicking the **Up** or **Down Arrow** taskbar icons, and then click **Save Moved Rows** to save the change.
 - Save the ACEs that you have moved with the Move To or Up and Down Arrow functions by clicking the **Save Moved Rows** taskbar icon.
 - Insert a new ACE before the selected row by clicking the **Insert** taskbar icon. The workflow for inserting is the same as for adding (described in the following steps).
 - Add a new ACE, as described in the steps that follow.
- a. Click the **Add ACE** taskbar icon.

Figure 4-12 *Edit ACE Pane*

Edit ACE ✖

Action:	<input type="text" value="Permit"/>	Protocol:	<input type="text" value="TCP"/>
Source IP Address: *	<input type="text" value="any"/>	Destination IP Address: *	<input type="text" value="any"/>
Source Wildcard:	<input type="text"/>	Destination Wildcard:	<input type="text"/>
Source Port Operator:	<input type="text" value="None"/>	Destination Port Operator:	<input type="text" value="None"/>
Source Port:	<input type="text"/>	Destination Port:	<input type="text"/>
Source Port End:	<input type="text"/>	Destination Port End:	<input type="text"/>
DSCP(0-63):	<input type="text"/>	Precedence:	<input type="text"/>

347554

- b. From the Action drop-down list, choose Permit or Deny, to determine whether this ACE permits or denies matched traffic.
- c. Enter values in one or more fields to create an ACE for a specific type of traffic. Enter **any** in the IP address fields to specify any IP address.
- d. Use the IP address wildcard fields to specify a range of IP addresses using a wildcard subnet mask in dotted decimal notation, for example, 0.0.0.255 for /24.
- e. Use the Source/Destination Port Operator drop-down lists to choose an operator and behavior for the port fields:
 - None—Port field is not used.
 - eq—Match requires traffic port to be equal to the Port field.
 - gt—Match requires traffic port to be greater than the Port field.
 - lt—Match requires traffic port to be less than the Port field.
 - neq—Match requires traffic port to be not equal to the Port field.
 - Range—Match requires traffic port to be within the range of ports from the Start Port field through the Port End field.

In the port fields, you can choose the port from a drop-down list or enter a numeric value.

- f. Set the differentiated services code point (DSCP) value. Alternatively, select a Precedence value from the Precedence drop-down list to set the priority.
The DSCP value must be between 0 and 63. Additionally, DSCP names are also allowed.
- g. Click **OK** to save the ACE.
- h. Add additional ACEs. Click **OK** to save the match condition and return to the Match Conditions list.

Step 10 (Optional) For a Protocol match condition type, follow these steps:

- a. From the Select Protocol drop-down list, choose the Microsoft RPC application identifier that identifies the traffic you want to match. For example, to match Microsoft Exchange Server traffic that uses the MAPI protocol, choose **mapi**.
- b. Click **OK** to save the match condition and return to the match conditions list.

Step 11 (Optional) For a Peer match condition type, select one or more peer devices. Follow these steps to create the match condition:

- a. From the Show drop-down list, choose a filter to filter the device list as needed. You can use Quick Filter, Show All Devices, or Show All Assigned Devices.
- b. Check the check box next to each device you want to match traffic from. You can check the check box next to the column title to select all the devices and uncheck it to deselect all devices.
- c. Click **OK** to save the match condition and return to the match conditions list.

Step 12 Click **OK** to save the class map and return to the Class Maps Configuration window.

Configuring Rules Within an AppNav Policy

The following topics are described here:

- [Configuring AppNav Policy Rules on a WAAS Appliance AppNav Cluster](#)
- [Configuring AppNav-XE Policy Rules on an AppNav-XE Cluster](#)

Configuring AppNav Policy Rules on a WAAS Appliance AppNav Cluster

To configure AppNav policy rules on a WAAS appliance AppNav cluster, follow these steps:

-
- Step 1** From the WAAS Central Manager menu, choose **AppNav Clusters** > *cluster-name*.
- Step 2** Choose **Configure** > **AppNav Cluster** > **AppNav Policies**.
The AppNav Policy window appears.
- Step 3** Choose the policy to configure from the AppNav Policy drop-down list at the top.
You can click **Manage** to create or delete a policy or configure the ANCs to which a policy is applied. For details see [Managing WAAS Appliance Policies](#).
From the AppNav Policy Rules area, you can perform the following tasks:
- From the Show drop-down list, choose the filter to filter the rule list as needed. You can use a Quick Filter or Show All Rules.
 - Edit a rule by selecting it and clicking the **Edit** taskbar icon.
 - Delete one or more rules by selecting them and clicking the **Delete** taskbar icon.
 - Move one or more selected rules to a new position by clicking the **Move To** taskbar icon. After moving the rows, click **Save Moved Rows** to save the change.
 - Move one or more selected rules up or down one position by clicking the **Up** or **Down Arrow** taskbar icons, and then click **Save Moved Rows** to save the change.
 - Insert a new rule before the selected row by clicking the **Insert** taskbar icon. The workflow for inserting is the same as for adding (described in the following steps).
 - Add a new rule at the end of the list, as described in the steps that follow. (The class-default rule is always pushed to the last position.)
- Step 4** Click the **Add Policy Rule** taskbar icon.

Figure 4-13 AppNav Policy Rule Pane

AppNav Policy Rule

AppNav Class-Map: HTTP

AppNav Action

Distribute To: WNG-Default

Backup: bkup

Monitor: HTTP Accelerator

▼ **Nested Actions (Advanced)**

Nested Policy: (None)

Class-Map	Distribute To	Monitor
No data available		

There are Policies ineligible to be specified as Nested Policy.

- Step 5** From the AppNav Class-Map drop-down list, choose the class map to which this policy rule applies. To edit the class map, click **Edit**. To create a new class map, click **Create New**. The workflow is the same, as described in [Configuring a WAAS Appliance AppNav Class Map](#).
- Step 6** From the Distribute To drop-down list, choose the distribution action to apply to the class map. The list includes all the defined WNGs and the various options: (None), for no action, and (Passthrough), to pass through this type of traffic. The meaning of None is context dependent: in a top-level policy it means pass-through, if this policy is nested, it means inherit the parent policy rule action.
- When you choose a WNG, other settings appear. To create a new WNG, click **Create New**. The workflow is the same as that described in [Adding a New WAAS Node Group to the Cluster](#). The newly created WNG appears in both the Distribute To and Backup drop-down lists.
- Step 7** (Optional) From the Backup drop-down list, choose the backup WNG to use for distribution if the primary WNG is unavailable.
- Step 8** (Optional) From the Monitor drop-down list, choose the application accelerator to monitor. When you monitor an application accelerator, the ANC checks for overload on that application accelerator and does not send new flows to a WN that is overloaded. If you choose None, a specific application accelerator is not monitored, only the maximum connection limit of the device is monitored.
- Step 9** (Optional) To apply a nested policy within this rule, click **Nested Actions (Advanced)** to expand this area.
- Step 10** (Optional) From the Nested Policy drop-down list, choose the policy to nest, or choose **None** to select no policy. When you choose a policy, the policy rules are displayed in a table.
- If there are policies that are ineligible to be specified as a nested policy, click **Show Ineligible Policies** to display them and the reasons they are ineligible. A policy is ineligible if it already has a nested policy, because only one level of nesting is allowed.

To edit the chosen policy, click **Edit**. To create a new policy for nesting, click **Create New**. The workflow for both editing and creating is the same.

- a. In the Name field, enter the policy name.



Note This field is not editable for the waas_app_default policy.

- b. Click the **Add Policy Rule** taskbar icon.
A new row is added, showing fields for configuring the rule.
- c. From the Class-Map drop-down list, choose the class map to which this rule applies.
- d. From the Distribute To drop-down list, choose the distribution action to apply to the class map. The list includes all the defined WNGs and the choices, Inherit, to inherit this action from the parent policy, and Passthrough, to pass through this type of traffic.
- e. (Optional) From the Backup drop-down list, choose the backup WNG to use for distribution if the primary WNG is unavailable.
- f. (Optional) From the Monitor drop-down list, choose the application accelerator to monitor.
- g. Click **OK** to save the policy rule and return to the AppNav Policy Rule pane for the primary policy rule you are creating.

Step 11 Click **OK** to create the policy rule and return to the policy configuration window.



Note If all the AppNav policies have been deleted and you add a new policy rule, the policy rule is added to a new appnav_default policy, which is created automatically.

Configuring AppNav-XE Policy Rules on an AppNav-XE Cluster

To configure AppNav policy rules on an AppNav-XE cluster, follow these steps:

Step 1 From the WAAS Central Manager menu, choose **AppNav Clusters** > *cluster-name*.

Step 2 Choose **Configure** > **AppNav Cluster** > **AppNav Policies**.

The AppNav Policy window appears.

Step 3 Click the radio button next to the policy you want to configure in the AppNav Policies table at the top of the window.

In the AppNav Policies table, you can perform the following tasks:

- Use the filter settings in the Show drop-down list to filter the rule list as needed. You can use Quick Filter or Show All Rules.
- Edit a policy by selecting it and clicking the **Edit** taskbar icon.
- Delete a policy by selecting it and clicking the **Delete** taskbar icon.
- Unassign a policy by selecting it and clicking the **Unassign Policy** taskbar icon.
- Add a policy by clicking the **Add Policy** taskbar icon.

For details on these tasks see [Managing AppNav-XE Policies](#).

The AppNav Policy Rules table in the lower part of the window shows the selected rules in the AppNav Policies table. From this table, you can perform the following tasks:

- From the Show drop-down list, choose a filter to filter the rule list as needed. You can use Quick Filter or Show All Rules.
- Edit a rule by selecting it and clicking the **Edit** taskbar icon.
- Delete one or more rules by selecting them and clicking the **Delete** taskbar icon.
- Move one or more selected rules to a new position by clicking the **Move To** taskbar icon. After moving the rows, click **Save Moved Rows** to save the change.
- Move one or more selected rules up or down one position by clicking the **Up** or **Down Arrow** taskbar icons, and then click **Save Moved Rows** to save the change.
- Insert a new rule before the selected row by clicking the **Insert** taskbar icon. The workflow for inserting is the same as for adding (described in the following steps).
- Add a new rule at the end of the list, as described in the steps that follow. (The class-default rule is always pushed to the last position.)

Step 4 Click the **Add Policy Rule** taskbar icon.

Figure 4-14 AppNav Policy Rule Pane

Step 5 From the AppNav Class-Map drop-down list, choose the class map to which this policy rule applies.

To edit the class map, click **Edit**. To create a new class map, click **Create New**. The workflow is the same as described in [Configuring a Class Map on an AppNav-XE Cluster](#).

Step 6 From the Distribute To drop-down list, choose the distribution action to apply to the class map. The list includes WNGs and the choices None, for no action, and Passthrough, to pass through this type of traffic. Here, the meaning of None is the same as Passthrough. For the default policy map, the WNG list includes the default WNG and any custom WNG that is a part of the assigned context. For a custom policy map, the WNG list includes default and custom WNGs that are not already assigned to another context.

When you choose a WNG, other settings appear. To create a new WNG, click **Create New**. The workflow is the same as described in [Adding a New WAAS Node Group to the Cluster](#). The newly created WNG appears in the Distribute To drop-down list.

Step 7 (Optional) From the Backup drop-down list, choose the backup WNG to use for distribution if the primary WNG is unavailable or overloaded.



Note The Backup WNG option is available only for cluster/s that have XE3.13 devices or later. It is recommended that prior to downgrading the WCM to a release up to 5.2.1, the Backup WNG must be removed from the AppNav-XE cluster and make sure WCM and AppNav-XE device configuration is in sync.

**Note**

PreXE3.13 controllers cannot be added to the cluster policy that has been configured with a backup WNG. A validation message is displayed while adding preXE3.13 controller to a cluster with backup WNG policy.

A cluster having pre 3.13 devices cannot be configured with backup WNG. The option for backup WNG will not be visible if the cluster has at least one pre-3.13 XE device.

**Note**

It is recommended that prior to downgrading XE to a Pre XE3.13 release, the Backup WNG must be removed from the AppNav-XE cluster. Ensure that the WCM and AppNav-XE device configuration is in sync.

- Step 8** (Optional) From the Monitor drop-down list, choose the application accelerator to monitor. When you monitor an application accelerator, the ANC checks for overload on that application accelerator and does not send new flows to a WN that is overloaded. If you choose None, a specific application accelerator is not monitored, only the maximum connection limit of the device is monitored.
- Step 9** Click **OK** to create the policy rule and return to the policy configuration window.

Managing AppNav Policies

The following topics are described here:

- [Managing WAAS Appliance Policies](#)
- [Managing AppNav-XE Policies](#)

Managing WAAS Appliance Policies

To create or delete AppNav policies or configure the ANCs to which policies apply in a WAAS appliance AppNav cluster, follow these steps:

- Step 1** From the WAAS Central Manager menu, choose **AppNav Clusters** > *cluster-name*.
- Step 2** Choose **Configure** > **AppNav Cluster** > **AppNav Policies**.
The AppNav Policy window appears.
- Step 3** Choose the policy to view from the AppNav Policy drop-down list at the top.
For details on using the AppNav Policy Rules area see [Configuring AppNav Policy Rules on a WAAS Appliance AppNav Cluster](#).
- Step 4** Click **Manage**.

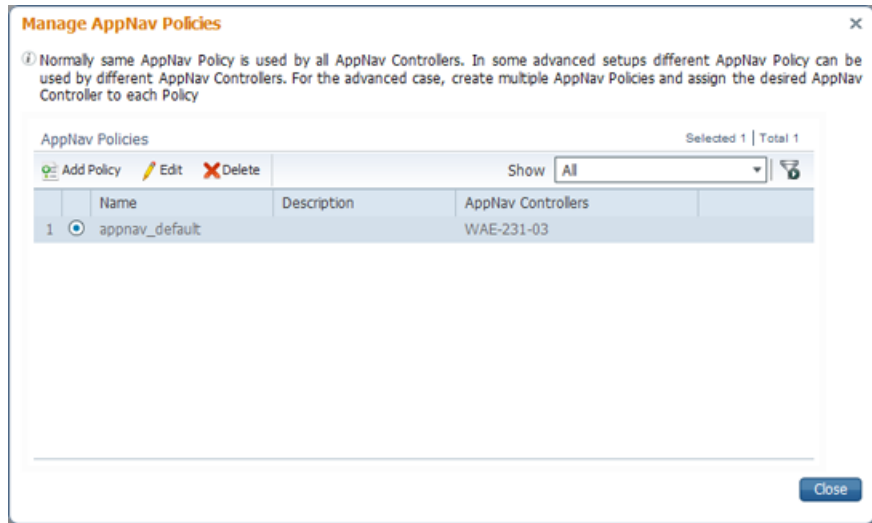
Figure 4-15 Manage AppNav Policies Pane

From the Manage AppNav Policies pane, you can perform the following tasks:

- From the Show drop-down list, choose a filter to filter the policy list as needed. You can use a Quick Filter or Show All Policies.
- Edit a policy and configure the ANCs to which it applies by selecting it and clicking the **Edit** taskbar icon.
- Delete a policy by selecting it and clicking the **Delete** taskbar icon.
- Add a new policy, as described in the steps that follow.

Step 5 Click the **Add Policy** taskbar icon.

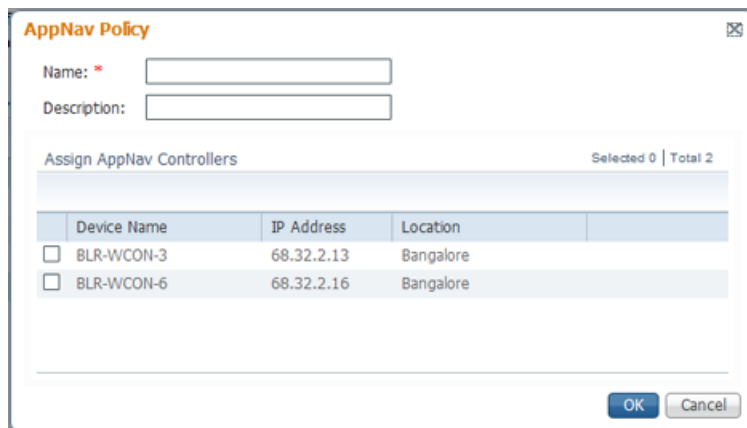
Figure 4-16 AppNav Policy Pane

Step 6 In the Name field, enter a name for the policy. A maximum of 40 alphanumeric characters, including an underscore, can be entered.

Step 7 (Optional) In the Description field, enter a description for the policy. A maximum of 200 alphanumeric characters, including underscore and space, can be entered.

- Step 8** (Optional) Check the check box next to each ANC that you want to assign to this policy. To unassign any assigned devices, uncheck the check box.
- Assigning a policy to an ANC makes the policy active on that ANC (only one policy can be active on an ANC) and removes the association of any previously active policy on that ANC. It is not necessary to assign a policy to an ANC if you want to create the policy as an alternative. You can assign it to ANCs later, as required.
- Step 9** Click **OK** to save the policy and return to the Manage AppNav Policies pane.
- Step 10** Click **Close** to return to the policy configuration window.
- Step 11** Add policy rules to the new policy as described in [Configuring AppNav Policy Rules on a WAAS Appliance AppNav Cluster](#).
-

To restore the default class maps and policy maps to your cluster, click the **Restore Default** taskbar icon at the top of the AppNav Policies window. This action removes all the existing class and policy map configurations and restores the default class and policy maps. All the WAAS nodes assigned to WNGs are moved to the default WNG, and other WNGs are removed.

Managing AppNav-XE Policies

To create or delete AppNav policies or unassign a policy from a context in an AppNav-XE cluster, follow these steps:

-
- Step 1** From the WAAS Central Manager menu, choose **AppNav Clusters** > *cluster-name*.
- Step 2** Choose **Configure** > **AppNav Cluster** > **AppNav Policies**.
- The AppNav Policy window appears.
- Step 3** Click the radio button next to the policy to modify, in the AppNav Policies table at the top of the window.
- From the AppNav Policies table, you can perform the following tasks:
- From the Show drop-down list, choose a filter to the rule list as required. You can use Quick Filter or Show All Rules.
 - Edit a policy by selecting it and clicking the **Edit** taskbar icon.
 - Delete a policy by selecting it and clicking the **Delete** taskbar icon.
 - Unassign a policy from a context by selecting it and clicking the **Unassign Policy** taskbar icon. Unassigning a policy from a context also disables the context and unassigns all the WNGs from the context. Click **OK** again to confirm that you want to proceed.
 - Add a new policy, as described in the steps that follow.
- For details on using the AppNav Policy Rules area, see [Configuring AppNav-XE Policy Rules on an AppNav-XE Cluster](#).
- Step 4** Click the **Add Policy** taskbar icon.

Figure 4-17 AppNav Policy Pane

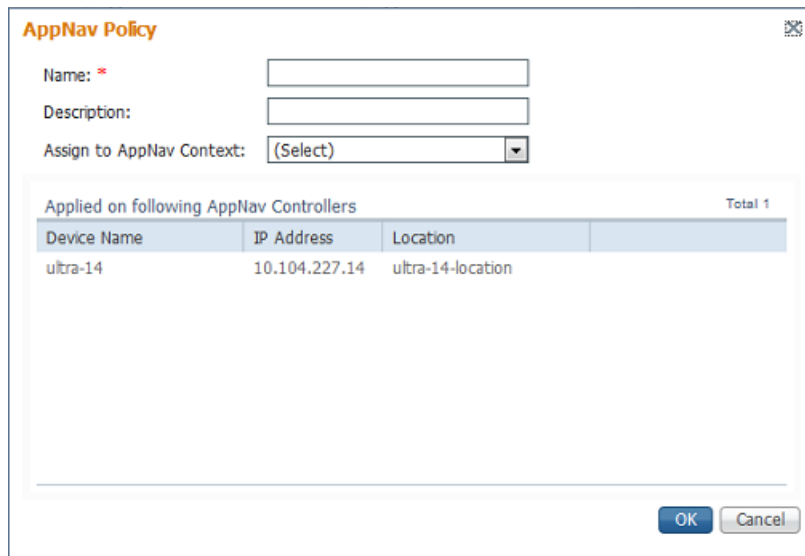

- Step 5** In the Name field enter a name for the policy. A maximum of up to 227 characters, excluding a space or question mark (?), can be entered. Do not use a name of the format APPNAV-*n*-PMAP, which is used for default policy maps.
- Step 6** (Optional) In the Description field, enter a description for the policy. A maximum of up to 200 characters, not including a question mark (?), can be entered.
- Step 7** From the Assign to AppNav Context drop-down list, choose the context to which to assign the new policy.
 Assigning the policy to a context makes the policy active on all the ANCs that are a part of the context. Only contexts that do not already have an assigned policy are listed.
 For default policy maps, only one context is displayed, based on the context ID. For example, for APPNAV-4-PMAP, only waas/4 is displayed (in case it is not already assigned).
- Step 8** Click **OK** to save the policy and return to the AppNav Policies window.
- Step 9** Add policy rules to the new policy as described in [Configuring AppNav-XE Policy Rules on an AppNav-XE Cluster](#).

To restore the default class maps and policy maps to your cluster, click the **Restore Default** taskbar icon at the top of the AppNav Policies window. This action removes all the existing class and policy map configurations and restores the default class and policy maps. All the WAAS nodes assigned to each context are moved to their respective default WNGs and all the unassigned WNGs are removed.

Configuring WAAS Node Optimization Policy

The WAAS node optimization policy controls how traffic that is distributed to the WAAS nodes is optimized. The optimization policy is configured on the WNs and the ANCs that are also acting as optimizing nodes.

All the WNs in one WNG must have an identical optimization policy configured on them. Otherwise, optimization of flows is not predictable. The optimization policy can be different for different WNGs.

For information on how to configure the optimization policy, see [Chapter 12, “Configuring Application Acceleration.”](#)

The default optimization policy is listed in [Appendix A, “Predefined Optimization Policy.”](#)

Configuring AppNav Controller ACLs

An AppNav Controller ACL controls what traffic is intercepted by a WAAS appliance ANC. You may want to configure an ANC interception ACL for each WAAS appliance ANC in an AppNav Cluster.

For information on how to configure an ANC interception ACL, see [Configuring Interception Access Control Lists](#) in Chapter 5, “Configuring Traffic Interception.”

Configuring AppNav Cluster Settings

To configure AppNav Cluster settings for an AppNav cluster, follow these steps:

-
- Step 1** From the WAAS Central Manager menu, choose **AppNav Clusters > All AppNav Clusters**.
The Manage AppNav Clusters window showing the status of each cluster appears.
From this window, you can perform the following tasks:
- Create a new AppNav Cluster. The workflow is the same as described in [Creating a New AppNav Cluster with the AppNav Cluster Wizard](#).
 - Delete an AppNav Cluster by selecting an AppNav Cluster and clicking the **Delete** icon in the taskbar of the Manage AppNav Clusters area.
 - View an AppNav Cluster topology and edit its settings as described in the steps that follow.
- Step 2** Click the name of the cluster whose settings you want to edit.
The cluster topology diagram appears.
- Step 3** Choose **Configure > AppNav Cluster > AppNav Cluster**.
The Cluster Configuration window appears.

Figure 4-18 Cluster Configuration Window

- Step 4** In the Name field, enter a new name for the cluster if you want to rename it. (This feature is not available on AppNav-XE clusters.)
- Step 5** (Optional) In the Description field, enter the cluster description. Use only letters and numbers, up to a maximum of 200 characters. (This feature is not available on AppNav-XE clusters.)
- Step 6** (Optional) In the Authentication Key and Confirm Authentication Key fields, enter an authentication key that is used to authenticate communications between the WAAS devices in the cluster. Use only letters and numbers, up to a maximum of 64 characters.
- Step 7** (Optional) In the Shutdown Wait Time field, enter the number of seconds that the WNs in the cluster should wait for all the connections to get terminated before shutting down. The default is 120 seconds.
- Step 8** (Optional) To configure cluster distribution and off-loading of pass-through connections, expand the **Advanced Settings** section by clicking it.
- Step 9** (Optional) To enable distribution of traffic from the ANCs in the cluster to WNs, ensure that the **Enable distribution of traffic on AppNav Controllers** check box is checked. To disable distribution of traffic, uncheck this box. When distribution is disabled, the cluster operates in monitoring mode where it continues to intercept traffic and, instead of distributing it to WNs, passes it through. This mode can be useful for monitoring traffic statistics without optimizing the traffic. (Not available on AppNav-XE clusters.)
- Step 10** (Optional) To configure offloading of pass-through connections from WNs to ANCs, check the check boxes in the **Enable offload of pass-through connections from WAAS nodes to AppNav Controllers for following reasons** section. This feature allows pass-through connections to be passed through at the ANC instead of being distributed to the WN and then passed through. Configure pass-through offload as follows:
- a. To offload all pass-through connections, which includes connections passed through due to error conditions, check the **All pass-through connections** check box. Check this check box only if you do not require application visibility on the WNs into pass-through traffic due to error conditions. The default is unchecked.
 - b. To offload connections passed through due to missing policy configuration, check the **Due to missing policy configuration** check box. By default, it is checked.

- c. To offload connections passed through due to the absence of peer WN, check the **Due to no peer WAAS node** check box. By default, it is checked.
- d. To offload connections passed through due to an intermediate WN, check the **Due to intermediate WAAS node** check box. By default, it is checked.
- e. If some of the WNs use different pass-through offload settings, you can synchronize the settings on all the WNs to match the configuration shown here by checking the **Synchronize settings on all devices** check box. This check box is shown only if the settings on some WNs are different. The default is unchecked.

Step 11 Click **Submit**.

The lower part of this window includes tabs that show lists of the ANCs, WNs, and WNGs that are a part of the cluster. On AppNav-XE devices, there is an additional AppNav Contexts tab that displays contexts. The controls in these parts of this window work as described in the following sections:

- AppNav Controllers—[Configuring AppNav Controller Settings](#)
- AppNav Contexts—[Configuring AppNav Contexts](#)
- WAAS Nodes—[Configuring WAAS Node Settings](#)
- WAAS Node Groups—[Configuring WAAS Node Group Settings](#)

To configure AppNav Cluster settings for an individual WN, see [Configuring AppNav Cluster Settings for a WAAS Node](#). If you are using an authentication key to authenticate communications, you must configure the cluster and each WN with the same key.

Configuring AppNav Controller Settings

The following topics are described hereAppNav:

- [Configuring AppNav Controller Settings for a WAAS Appliance](#)
- [Configuring ANC Settings for an AppNav-XE Device](#)

Configuring AppNav Controller Settings for a WAAS Appliance

To configure ANC settings for a WAAS appliance, follow these steps:

Step 1 From the WAAS Central Manager menu, choose **AppNav Clusters** > *cluster-name*.

Step 2 Click the **AppNav Controllers** tab below the topology diagram.

All the ANCs in the cluster are listed, along with the name, location, IP address, and interface used for intracluster traffic, and enabled status.

From this list, you can perform the following tasks:

- Edit the interface settings for an ANC by choosing the ANC and clicking the **Edit** taskbar icon, as described in the following steps.
- Delete an ANC by choosing the ANC and clicking the **Delete** taskbar icon.
- Add a new ANC to the cluster by clicking the **Add AppNav Controller** taskbar icon. See [Adding an ANC to a Cluster](#).
- Enable a disabled ANC by choosing the cluster and clicking the **Enable** taskbar icon.

- Disable an ANC by choosing the ANC and clicking the **Disable** taskbar icon.
- Step 3** Click the radio button next to the ANC that you want to edit and click the **Edit** taskbar icon.
The Edit AppNav Controller pane appears.
- Step 4** Configure the internal WAAS node settings:
- a. To enable optimization on the ANC, check the **Enable WAN optimization (Internal WAAS Node)** check box.
 - b. If you enabled WAN optimization, from the **WAAS Node Group** drop-down list, choose the WNG to which the internal WN should belong.
 - c. Click **Next**.
- Step 5** (Optional) Configure the WCCP settings for the ANC. This window does not appear if the ANC is configured for inline interception. For more information on the WCCP fields, see the [“Configuring or Viewing the WCCP Settings on ANCs”](#) section on page 5-22.
When finished with the WCCP settings, click **Next**.
The graphical interface wizard appears.
- Step 6** Configure the interception and cluster interface settings:
- a. In the graphical interface view, configure interception interfaces on the AppNav Controller Interface Module, as required. For details on how to use the wizard, see [Configuring Interfaces with the Graphical Interface Wizard](#).
 - b. From the Cluster Interface drop-down list, choose the interface to be used for intracluster traffic.
 - c. (Optional) To enable swapping of client and WAAS device source IP address fields in intra-cluster traffic, check the **Enable swapping of source IP address in intra-cluster traffic** check box.

You may want to enable this option if you are using a port channel for the cluster interface or there is a load-balancing device between the ANC and WN. This option can improve the load balancing of the traffic that the ANC distributes to WNs for optimization because it load balances based on the client IP address rather than the ANC IP address. (For traffic from the server to the client, it swaps the server IP address with the ANC IP address.) The Central Manager enables this feature automatically if any existing ANCs have port channel cluster interfaces.
- Step 7** Click **Finish**.
-

Configuring ANC Settings for an AppNav-XE Device

To configure ANC settings for an AppNav-XE device, follow these steps:

-
- Step 1** From the WAAS Central Manager menu, choose **AppNav Clusters** > *cluster-name*.
- Step 2** Click the **AppNav Controllers** tab below the topology diagram.
All the ANCs in the cluster are listed, along with the name, location, IP address, interface used for intracluster traffic, and enabled status.
From this list, you can perform the following tasks:
- Edit the interface settings for an ANC by choosing the ANC and clicking the **Edit** taskbar icon, as described in the following steps.
 - Delete an ANC by choosing the ANC and clicking the **Delete** taskbar icon.

- Add a new ANC to the cluster by clicking the **Add AppNav Controller** taskbar icon. See [Adding an ANC to a Cluster](#).
- Step 3** Click the radio button next to the ANC that you want to edit and click the **Edit** taskbar icon. The Edit AppNav Controller pane appears.
- Step 4** On an AppNav-XE cluster, configure the interception and cluster interface settings:
- a. Choose the WAN interfaces on which traffic interception is to be enabled. Interfaces must already be configured on the AppNav-XE devices; only those on which service insertion can be enabled are listed.
 - b. From the Cluster Interface drop-down list, choose the interface to be used for intra-cluster traffic.
- Step 5** Click **Finish**.
-

Configuring AppNav Contexts

An AppNav-XE cluster can have up to 32 contexts. A WAAS appliance AppNav cluster can have only one context, which is defined by the cluster settings; the ability to add contexts is not available.

To configure AppNav contexts, follow these steps:

-
- Step 1** From the WAAS Central Manager menu, choose **AppNav Clusters** > *cluster-name*.
- Step 2** Click the **AppNav Contexts** tab below the topology diagram.
- All the AppNav contexts in the cluster are listed, along with the name, associated WNGs, VRFs, the AppNav policy, and enabled status.
- From this list, you can perform the following tasks:
- Edit a context by choosing the context and clicking the **Edit** taskbar icon.
 - Delete a context by choosing the context and clicking the **Delete** taskbar icon.
 - Enable a disabled context by choosing the context and clicking the **Enable** taskbar icon.
 - Disable a context by choosing the context and clicking the **Disable** taskbar icon.
 - Add a new context as described in the steps that follow. (This feature is not allowed for WAAS appliance clusters.)
- Step 3** Click the **Add AppNav Context** taskbar icon.
- Step 4** From the WAAS Cluster Id drop-down list, choose the cluster ID to assign to this context. The first available ID is initially selected.
- Step 5** (Optional) In the AppNav Policy Name field, specify the name of the AppNav policy to associate with the cluster. A default suggested policy name initially appears in the field, which you can change if you want to. If you enter the name of a policy that does not exist, it is created.



Note You cannot specify a name that uses the same form as the default name but with a number that is different from the context ID, because such names are reserved for the default policy maps associated with contexts.

- Step 6** (Optional) In the WAAS Node Group field, specify the name of the WNG to associate with the context. A default suggested WNG name initially appears in the field, which you can change if desired. If you enter the name of a WNG that does not exist, it is created. To associate a WNG with a context, the WNG must be used in policy rules that are used in the context.
- You cannot specify a name that uses the same form as the default name but with a number different than the context ID, because such names are reserved for the default WNGs associated with contexts.
- Step 7** Click **Next**.
- Step 8** Select one or more VRFs to associate with the context. Follow these steps:
- From the Show drop-down list, choose a filter the VRF list, as required. You can use Quick Filter or Show All VRFs. The lower part of the pane lists ineligible VRFs, along with the reason why each is ineligible.
 - Check the check box next to each VRF that you want to associate with the context.
 - Click **Next**.
- Step 9** Choose the WN devices that you want to be a part of the WNG associated with the context:
- Choose WNs in the WAAS Nodes device list by checking the check box next to the device names. You can use the filter settings in the taskbar to filter the device list.
- If there are devices that are ineligible to join the cluster, click **Show Ineligible Devices** to see them and the reasons why they are ineligible. You can use the filter settings to filter the list.
- Click **Next**.
- Step 10** Configure the cluster interface settings for each WN device in the context.
- The Cluster Interface wizard appears, with one screen for each WN in the context:
- Configure individual interfaces, as required, on the device by using the Graphical Interface wizard. For details on how to use the wizard, see [Configuring Interfaces with the Graphical Interface Wizard](#).
 - From the Cluster Interface drop-down list, choose the interface to be used for intra-cluster traffic.
 - Click **Next**.
- If you are configuring multiple WNs, a similar screen is shown for each device.
- Step 11** Click **Finish** to save the context configuration.
-

Configuring WAAS Node Settings

All the WNs in a WAAS appliance cluster must be configured with application-accelerator device mode and appnav-controller interception mode. If you created the cluster with the Central Manager AppNav Wizard, both of these settings are already in place. (The wizard sets the interception, and the device mode would have been set before the wizard is run.)

From within the AppNav Cluster, you can configure the following settings for a WN:

- WNG to which a WN belongs
- AppNav Controller Interface Module interface settings (including configuring port channel, standby, and bridge group interfaces)
- Cluster interface used for intracluster traffic

To configure WN settings, follow these steps:

-
- Step 1** From the WAAS Central Manager menu, choose **AppNav Clusters** > *cluster-name*.
- Step 2** Click the **WAAS Nodes** tab below the topology diagram.
- All the WNs in the cluster are listed, along with the name, location, IP address, interface in use, WNG to which the node belongs, and enabled status.
- From this list, you can perform the following tasks:
- Edit the settings for a WN by choosing the WN and clicking the **Edit** taskbar icon.
 - Delete a WN by choosing the WN and clicking the **Delete** taskbar icon.
 - Add a new WN to the cluster by clicking the **Add WAAS Node** taskbar icon. See [Adding a New WAAS Node to the Cluster](#).
 - Enable a disabled WN by choosing the node and clicking the **Enable** taskbar icon.
 - Disable a WN by choosing the node and clicking the **Disable** taskbar icon.
- Step 3** Click the radio button next to the WN that you want to edit and click the **Edit** taskbar icon.
- The WAAS Node pane appears.
- Step 4** From the WAAS Node Group drop-down list, choose the WNG to which you want to assign the node.
- Step 5** In the graphical interface view, configure interfaces on the device, as required. For details on how to use the wizard, see [Configuring Interfaces with the Graphical Interface Wizard](#).
- Step 6** From the Cluster Interface drop-down list, select the interface to be used for intra-cluster traffic.
- Step 7** (Optional) To enable swapping of client and WAAS device source IP address fields in intra-cluster traffic, check the **Enable swapping of source IP address in intra-cluster traffic** check box. (This option is not available for WNs used in an AppNav-XE cluster.)
- Enable this option if you are using a port channel for the cluster interface or there is a load-balancing device between the ANC and WN. This option can improve load balancing of the traffic that the ANC distributes to WNs for optimization because it load balances based on the client IP address rather than the ANC IP address. (For traffic from the server to the client, it swaps the server IP address with the ANC IP address.) The Central Manager enables this feature automatically if any existing ANCs have port channel cluster interfaces.
- Step 8** Click **OK** to save the settings.
-

Configuring WAAS Node Group Settings

To configure WNG settings, follow these steps:

-
- Step 1** From the WAAS Central Manager menu, choose **AppNav Clusters** > *cluster-name*.
- Step 2** Click the **WAAS Node Groups** tab below the topology diagram.
- All the WNGs in the cluster are listed, along with the name, description, and the WNs contained in the group. In an AppNav-XE cluster, the list also shows the WAAS cluster ID.
- From this list, you can perform the following tasks:
- Edit the settings for a WNG by choosing the WNG and clicking the **Edit** taskbar icon.
 - Delete a WNG by choosing the WNG and clicking the **Delete** taskbar icon.

- Add a new WNG to the cluster by clicking the **Add WAAS Node Group** taskbar icon. See [Adding a New WAAS Node Group to the Cluster](#).
- Step 3** Click the radio button next to the WNG that you want to edit and click the **Edit** taskbar icon.
- Step 4** (Optional) In the Description field, enter a description of the WNG, with up to 32 alphanumeric characters on a WAAS appliance cluster. For an AppNav-XE cluster, you can enter up to 241 characters, not including a space.
- Step 5** Click **OK** to save the settings.

To associate a newly created WNG with the desired context in an AppNav-XE cluster, you must use it in the AppNav policy rules of the context. For one or more rules, choose the WNG for the Distribute To action of the policy rule.

Configuring AppNav Cluster Settings for a WAAS Node

The WAAS Node Configuration window is available for a WN only if the device mode is configured as appnav-controller. This window is editable only if the WN is running WAAS Version 5.2.1 or later, and is not a part of an AppNav cluster.

To configure AppNav Cluster settings at the WAAS node level, follow these steps:

-
- Step 1** From the WAAS Central Manager menu, choose **Devices** > *device-name*.
- Step 2** Choose **Configure** > **AppNav Cluster** > **AppNav Cluster**.

The WAAS Node Configuration window appears.

Figure 4-19 WAAS Node Configuration Window

The screenshot shows the 'WAAS Node Configuration' window. At the top, there is a navigation bar with 'Home', 'Device Groups', 'Devices', 'AppNav Clusters', and 'Locations'. Below this, the current device is identified as 'wae-55-04' with options for 'Configure', 'Monitor', and 'Admin'. The breadcrumb path is 'Devices > wae-55-04 > Configure > AppNav Cluster > AppNav Cluster'. There are 'Print' and 'Refresh' icons. A note states: 'Current applied settings from AppNav Cluster, cluster-1(selected by user) - Settings applied for AppNav Cluster and AppNav Policy Rules'.

WAAS Node Configuration

- Enable WAAS Node
- Description:
- Authentication key:
- Confirm authentication key:
- Shutdown Wait Time: * (0-86400) seconds
- Enable WAAS Node Auto Discovery
- WAAS Node Auto Discovery Interface:

Buttons:

353994

- Step 3** (Optional) To enable this WN to handle traffic distributed by the ANC, check the **Enable WAAS Node** check box.
- Step 4** (Optional) In the Description field, enter the WN description. Use only letters and numbers, up to a maximum of 200 characters are allowed.
- Step 5** (Optional) In the Authentication Key and Confirm Authentication Key fields, enter an authentication key that is used to authenticate communications between the WN and the ANC. Use only letters and numbers, up to a maximum of 64 characters.
- Step 6** (Optional) In the Shutdown Wait Time field, enter the number of seconds that the WN should wait for all the connections to be terminated before shutting down. The default is 120 seconds.
- Step 7** (Optional) To enable automatic discovery of this WN by the ANC, check the **Enable WAAS Node Auto Discovery** check box. (This feature is not used on WNs with WAAS Version 5.1 and earlier.)
This setting is intended to allow an AppNav-XE ANC to discover WNs that are to participate in a cluster that is created by the CLI and not configured by the Central Manager.
- Step 8** From the WAAS Node Auto Discovery Interface drop-down list, choose the WN interface that is to be used for auto discovery. (This feature is not used on WNs with WAAS version 5.1 and earlier.)
- Step 9** Click **Submit**.

To configure AppNav Cluster settings at the cluster level, see [Configuring AppNav Cluster Settings](#). If you are using an authentication key to authenticate communications, you must configure the cluster and each WN with the same key.

**Note**

Do not use both automatic node discovery and the Central Manager to add a WN to an AppNav-XE cluster. We recommend that you disable automatic node discovery in AppNav-XE and then register the device and add it to the cluster with the Central Manager.

Adding and Removing Devices from the AppNav Cluster

This section includes these topics:

- [Adding an ANC to a Cluster](#)
- [Removing or Disabling an ANC from a Cluster](#)
- [Adding a New WAAS Node to the Cluster](#)
- [Removing a WAAS Node from a Cluster](#)
- [Adding a New WAAS Node Group to the Cluster](#)
- [Removing a WAAS Node Group from a Cluster](#)

Adding an ANC to a Cluster

To add a new ANC to an AppNav Cluster, follow these steps:

-
- Step 1** Configure the basic device and network settings on each new ANC, and ensure that the device mode is set to appnav-controller on a WAAS appliance.
- Step 2** From the WAAS Central Manager menu, choose **AppNav Clusters** > *cluster-name*.

- Step 3** Click the **AppNav Controllers** tab below the topology diagram.
- Step 4** Click the **Add AppNav Controller** taskbar icon.
The Add AppNav Controllers pane appears.
- Step 5** Select the ANC devices to add:
- Select one or more ANCs in the AppNav Controller device list by checking the check boxes next to the device names. You can use the filter settings in the taskbar to filter the device list.

If there are devices that are ineligible to join the cluster, click **Show Ineligible Devices** to see them and the reasons why they are ineligible. You can use the filter settings to filter the list.
 - Click **Next**.
- Step 6** Configure the interception method, policy, WCCP settings (if using WCCP interception), VRFs, and interfaces for each ANC device you are adding (different screens and options appear for WAAS appliance and AppNav-XE clusters):
- From the Interception Method drop-down list, choose **WCCP** or **Inline**. (This feature is not used on AppNav-XE clusters.)
 - From the AppNav Policy-Map drop-down list, choose the AppNav policy to apply to the ANC. (Not used on AppNav-XE clusters.)
 - (Optional) To enable optimization on the ANC devices, check the **Enable WAN optimization (Internal WAAS Node)** check box. (This feature is not used on AppNav-XE clusters.)
 - (Optional) If you enabled WAN optimization, from the WAAS Node Group drop-down list, choose the WNG to which the internal WN should belong. (This feature is not used on AppNav-XE clusters.)
 - Click **Next**.
 - (Optional) If you chose WCCP interception, configure the WCCP settings on the WCCP settings pane that appears. For details on WCCP settings, see [Configuring or Viewing the WCCP Settings on ANCs](#) in Chapter 5, “Configuring Traffic Interception.”
-  **Note** Remember to check the **Enable WCCP Service** check box to enable WCCP.
- If you configured WCCP settings, click **Next**.
 - On an AppNav-XE cluster, choose the VRF instances to associate with the service context by checking the check box next to each VRF instance that you want to use. If you choose the VRF default, you cannot choose other VRFs. If you choose multiple VRFs, they must not have overlapping source IP addresses. Only VRFs that are available on all the ANCs are listed.
 - Click **Next**.
 - Configure the ANC interception interfaces. On a WAAS appliance cluster, you use the Cluster Interface Wizard graphical interface and on an AppNav-XE cluster, choose from a list of router interfaces. If you chose inline interception on a WAAS appliance, you must configure a bridge group interface. For details on using the wizard, see the [Configuring Interfaces with the Graphical Interface Wizard](#).
 - From the Cluster Interface drop-down list, select the interface to be used for intracluster traffic.
 - (Optional) To enable swapping of client and WAAS device source IP address fields in intracluster traffic, check the **Enable swapping of source IP address in intra-cluster traffic** check box. (Not available on AppNav-XE clusters.)

Enable this option if you are using a port channel for the cluster interface or there is a load-balancing device between the ANC and WN. This option can improve load balancing of the traffic that the ANC distributes to WNs for optimization because it load balances based on the client IP address rather than the ANC IP address. (For traffic from the server to the client, it swaps the server IP address with the ANC IP address.) The Central Manager enables this feature automatically if any existing ANCs have port channel cluster interfaces.

- m. Click **Next** to save the settings and continue with the next ANC you are adding. If this is the last ANC being added, click **Finish**.

After a convergence waiting period of up to two minutes, the new ANCs are available in the cluster for traffic interception and distribution. Traffic interception on the new ANCs is prevented until the devices have fully joined the cluster. You can monitor the ANC status as described in [Monitoring an AppNav Cluster](#).

Removing or Disabling an ANC from a Cluster

To gracefully remove an ANC from an AppNav Cluster, follow these steps:

-
- Step 1** Disable the traffic interception path on the ANC. For an inline ANC, shut down the in-path interfaces, and for an ANC using WCCP, disable WCCP.
Traffic that was previously routed to this ANC is rerouted to other ANCs in the cluster.
 - Step 2** Disable the ANC (not necessary on an AppNav-XE cluster):
 - a. From the WAAS Central Manager menu, choose **AppNav Clusters** > *cluster-name*.
 - b. Click the **AppNav Controllers** tab below the topology diagram.
 - c. Click the radio button next to the ANC that you want to disable and then click the **Disable** taskbar icon.

The ANC is disabled and the service unreachable alarm is raised on the other ANCs in the cluster.

To permanently remove the ANC, click the radio button next to the ANC that you want to remove and then click the **Delete** taskbar icon.

This action removes the ANC from the ANCG on all the other ANCs and clears the service unreachable alarm on the other ANCs. If the ANC is configured for WCCP interception, all the WCCP settings on the device are removed. If the ANC is also configured as a WN, the WN is removed from the cluster.
 - Step 3** (Optional) Power down the ANC.
-

Adding a New WAAS Node to the Cluster

To add a new WAAS node (WN) to a cluster, follow these steps:

-
- Step 1** From the WAAS Central Manager menu, choose **AppNav Clusters** > *cluster-name*.
 - Step 2** Click the **WAAS Nodes** tab below the topology diagram.
 - Step 3** Click the **Add WAAS Node** taskbar icon.
The Add WAAS Nodes pane appears.

- Step 4** Select one or more WNs in the WAAS Nodes device list by checking the check boxes next to the device names. You can use the filter settings in the taskbar to filter the device list.
- If there are devices that are ineligible to join the cluster, click **Show Ineligible Devices** to see them and the reasons why they are ineligible. You can use the filter settings to filter the list.
- Step 5** Click **Next**.
- Step 6** Configure the WNG and interfaces for each WN device you are adding:
- From the WAAS Node Group drop-down list, choose the WNG to which you want to add the new WNs. The list shows only the defined WNGs.
 - Click **Next**.
 - Use the Cluster Interface Wizard graphical interface to configure the WN interfaces. For details on using this wizard, see [Configuring Interfaces with the Graphical Interface Wizard](#).
 - From the Cluster Interface drop-down list, select the interface to be used for intra-cluster traffic.
 - (Optional) To enable swapping of client and WAAS device source IP address fields in intra-cluster traffic, check the **Enable swapping of source IP address in intra-cluster traffic** check box. (Not available for AppNav-XE clusters.)

Enable this option if you are using a port channel for the cluster interface, or there is a load-balancing device between the ANC and WN. This option can improve load balancing of the traffic that the ANC distributes to WNs for optimization because it load balances based on the client IP address rather than the ANC IP address. (For traffic from the server to the client, it swaps the server IP address with the ANC IP address.) The Central Manager enables this feature automatically if any existing ANCs have port channel cluster interfaces.
 - Click **Next** to save the settings and continue with the next WN you are adding. If this is the last WN being added, click **Finish**.
- Step 7** Configure and enable optimization on the WNs. For details on configuring optimization, see [Chapter 12, “Configuring Application Acceleration.”](#)

After a convergence waiting period of up to two minutes, the new WNs are available on all the ANCs for optimization.

Removing a WAAS Node from a Cluster

To remove a WAAS node (WN) from a cluster, follow these steps:

-
- Step 1** From the WAAS Central Manager menu, choose **AppNav Clusters > cluster-name**.
- Step 2** Click the **WAAS Nodes** tab below the topology diagram.
- Step 3** Choose the node and click the **Disable** taskbar icon.

This causes a graceful exit of the WN from the cluster. The ANCs stop sending new flows to the WN but continue to distribute existing flows to it until the connection count reaches zero, or the maximum shutdown wait time expires.



Note The default shutdown wait time is 120 seconds. You can configure it from the Shutdown Wait Time field in the AppNav Cluster tab.

Step 4 (Optional) When the graceful exit process on the WN is complete (all existing connections have terminated), remove the WN from the WNG on the ANCs by choosing the node and clicking the **Delete** taskbar icon.

You can monitor the node status in the topology diagram in the upper part of the window. The colored status light indicator on the device turns gray when the node is no longer processing connections.

Step 5 (Optional) Power down the WN.

Adding a New WAAS Node Group to the Cluster

To add a new WNG to a cluster, follow these steps:

Step 1 From the WAAS Central Manager menu, choose **AppNav Clusters** > *cluster-name*.

Step 2 Click the **WAAS Node Groups** tab below the topology diagram.

Step 3 Click the **Add WAAS Node Group** taskbar icon.

The Add WAAS Node Group pane appears.

Step 4 In the Name field, enter the name of the WNG. On a WAAS appliance cluster, you can enter up to 32 alphanumeric characters, and on an AppNav-XE cluster, you can enter up to 64 characters, excluding a space.

Step 5 (Optional) In the Description field, enter a description of the WNG. You can enter up to 200 alphanumeric characters, including ' | \ ; ` on a WAAS appliance cluster. In an AppNav-XE cluster, you can enter up to 241 characters, excluding a space.

Step 6 Click **OK** to save the settings.

Step 7 Add one or more WNs to the new WNG. To add a new WN, see [Adding a New WAAS Node to the Cluster](#), or to reassign an existing WN to the new WNG, see [Configuring WAAS Node Settings](#).

After a convergence waiting period of up to two minutes, the new WNG is available on all the ANCs for optimization.

Removing a WAAS Node Group from a Cluster

To remove a WAAS node group (WNG) from a cluster, follow these steps:

Step 1 From the WAAS Central Manager menu, choose **AppNav Clusters** > *cluster-name*.

Step 2 Click the **WAAS Nodes** tab below the topology diagram.

Step 3 Click the radio button next to the node name you want to disable and click the **Disable** taskbar icon. This causes a graceful exit of each WN from the cluster.

Step 4 After all WNs have completed a graceful exit from the cluster, click the **WAAS Node Groups** tab.

You can monitor the node status in the topology diagram in the upper part of the window. The colored status light indicator on the device turns gray when the node is no longer processing connections.

Step 5 (Optional) Choose the WNG you want to remove, and click the **Delete** taskbar icon.

Monitoring an AppNav Cluster

To monitor an AppNav Cluster, follow these steps:

- Step 1** From the WAAS Central Manager menu, choose **AppNav Clusters** > *cluster-name*.
The cluster home window displays the cluster topology and device status (see [Figure 4-17](#)).

Figure 4-20 AppNav Cluster Topology and Status

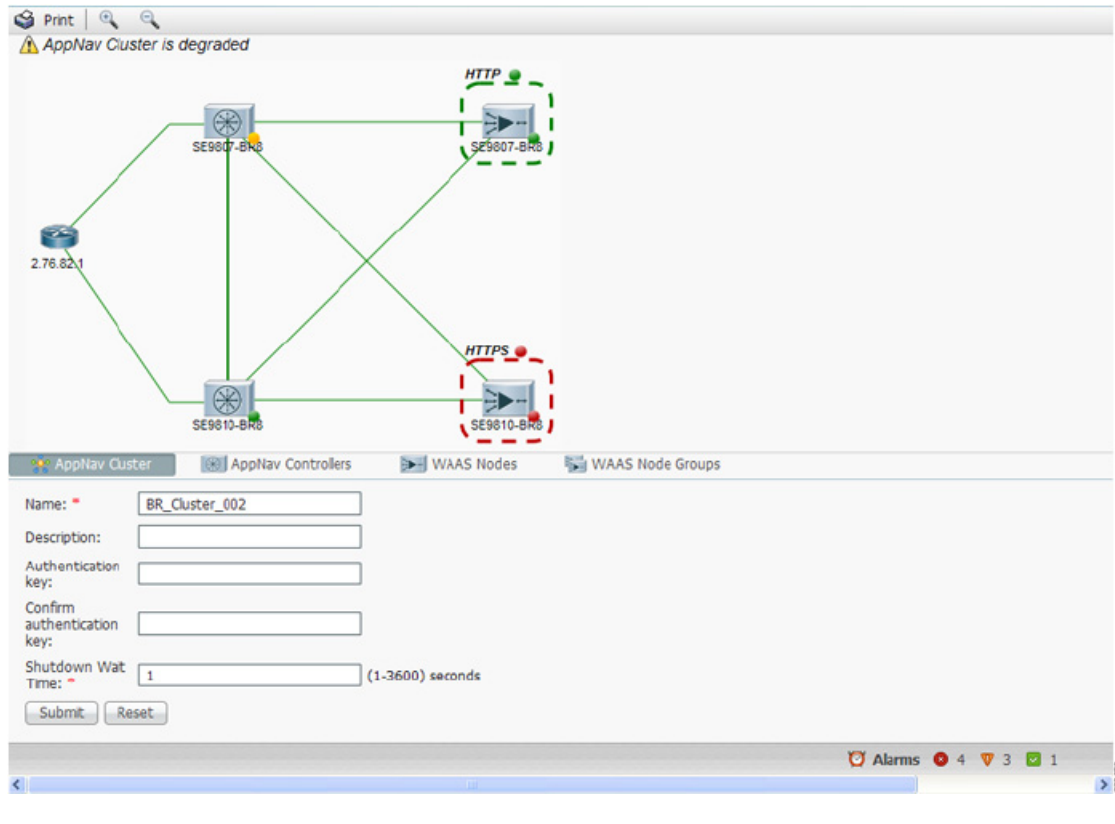

To zoom in or out on the topology diagram, click the + or – magnifying glass icons in the taskbar. You can also click on the diagram and drag it within the window to reposition it.

To change the cluster settings, edit any of the fields in the Cluster Settings tab below the topology diagram and click **Submit**.



Note On AppNav-XE clusters, the Name and Description fields are not shown.

To see all the AppNav contexts, click the **AppNav Contexts** tab below the diagram. From this tab, you can edit, delete, add, enable, or disable an AppNav context. This tab is not shown on WAAS appliance clusters.

To see all the ANCs, click the **AppNav Controllers** tab below the diagram. From this tab, you can edit, delete, add, enable, or disable an ANC in the cluster.

To see all the WNs, click the **WAAS Nodes** tab below the diagram. From this tab, you can edit, delete, add, enable, or disable a WN in the cluster.

To see all the WNGs, click the **WAAS Node Groups** tab below the diagram. From this tab, you can edit, delete, or add a WNG in the cluster.

The overall cluster status is shown in the top left corner of the diagram, as follows:

- Green—All the ANCs are operational with no error conditions.
- Yellow—Degraded because one or more ANCs have operational issues. This is also the initial state before all the nodes have sent status updates.
- Red—Cluster is down because all the ANCs are down, or indicates a split cluster where there is no connectivity between one or more ANCs.

The overall cluster status does not include administratively disabled ANCs.

The colored status light indicators on each device and dotted lines around each WNG show the status of the device or group:

- Green—Operational with no error conditions
- Yellow—Degraded (overloaded, joining cluster, or has other noncritical operational issues)
- Red—Critical (one or more processes is in a critical state)
- Gray—Disabled
- Black—Unknown status

The colored lines between each device show the status of the link between devices:

- Green—Operational with no error conditions
- Red—Link is down
- Black—Unknown status

A red plus symbol is shown on the upper right corner of any device that is added to an AppNav-XE cluster by automatic node discovery. The cluster configuration of such a device is not being managed by the Central Manager and you should verify that its configuration is correct. Additionally, statistics from the device are not aggregated in any Central Manager reports if the device is not registered to the Central Manager; if the device is registered to the Central Manager, its optimization (but not AppNav) statistics are included in Central Manager reports.



Note

Do not use both automatic node discovery and the Central Manager to add a WN to an AppNav-XE cluster. We recommend that you disable automatic node discovery in AppNav-XE and then register the device and add it to the cluster with the Central Manager. For details on configuring auto discovery, see [Configuring AppNav Cluster Settings for a WAAS Node](#).

An orange triangle  warning indicator is shown on any device for which the Central Manager may not have current information because the device has not responded within the last 60 seconds (the device could be offline or unreachable).



Note

A recently removed device still appears in the topology diagram for a few minutes until all the devices agree on the new cluster topology.

To view a more comprehensive device status display, hover your cursor over a device icon to see the 360-degree Network Device View dialog box ([Figure 4-18](#)). (The dialog box for a WN device is similar.)

Figure 4-21 ANC 360-Degree Network Device View

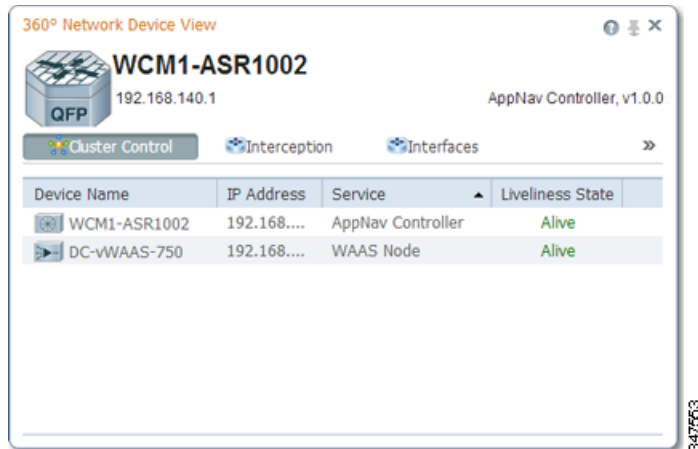

The 360-degree Network Device View shows the following status information:

- Device name and IP address.
- Device type and software version.
- (ANC only) Interception tab that displays the interception method for a WAAS appliance (Inline or WCCP). For inline, this tab shows the bridge groups defined for interception, their member interfaces, and their status. For WCCP, this tab lists the defined WCCP service IDs, their associated client IP addresses, router IP address, and notes about problems. For an AppNav-XE device, this tab shows the router interfaces on which interception is enabled and their status.
- (ANC only) Overloaded Policies tab that lists monitored AppNav policies that are overloaded. (Not shown on AppNav-XE devices.)
- (ANC only) Cluster Control tab that lists all the devices in the cluster, along with device name, IP address, service type, liveliness state, and reason for any error condition.
- (WN only) Optimization tab that lists the application accelerators and their status.
- Alarms tab that lists pending alarms on the device. (Not shown on AppNav-XE devices.)
- Interfaces tab that lists the device interfaces and status. You can filter the list by choosing a filter type from the drop-down list above the interface list, entering filter criteria, and clicking the filter icon.

You can pin the status dialog box so it stays open by clicking the pin icon in the upper right corner. You can also drag the dialog box to any location within your browser window.

For additional cluster status, you can view the **Monitor > AppNav > AppNav Report**, as described in the [AppNav Report](#) in Chapter 16, “Troubleshooting Your WAAS Network.”

If you have multiple AppNav Clusters, you can see the brief status for all of them at once by choosing **AppNav Clusters > All AppNav Clusters** from the menu.

To trace connections in a WAAS appliance cluster, see [AppNav Connection Tracing](#).

To view connection statistics in an AppNav-XE cluster, see [AppNav Connection Statistics](#).

For additional advanced AppNav troubleshooting information, see [Troubleshooting AppNav](#) in the *Cisco WAAS Troubleshooting Guide for Release 4.1.3 and Later*.

**Note**

You may see a taskbar icon named Force Settings on all the Devices in a Group if the configuration across all the ANC's in the cluster becomes unsynchronized. If you see the icon, it means that the cluster settings, ANC configuration, WN configuration, and WNG configuration do not match on all the ANC's in the cluster. This problem can occur if you configure a device outside the Central Manager by using the CLI. Click this taskbar icon to update all the devices with the configuration that is currently shown in the Central Manager for the cluster.

AppNav Connection Tracing

To assist in troubleshooting AppNav flows in a WAAS appliance cluster, use the Connection Trace tool in the Central Manager. This tool shows the following information for a particular connection:

- Whether the connection was passed through or distributed to a WNG
- Pass-through reason, if applicable
- The WNG and WN to which the connection was distributed
- Accelerator monitored for the connection
- Class-map applied

To use the Connection Trace tool, follow these steps:

- Step 1** From the WAAS Central Manager menu, choose **AppNav Clusters** > *cluster-name*.
- Step 2** Choose **Monitor** > **Tools** > **Connection Trace**.
- Step 3** From the AppNav Controller drop-down list, choose the ANC that has the connection that you want to trace.
- Step 4** From the Site (Remote Device) drop-down list, choose the peer WAAS device at the remote site.
- Step 5** In one or more of the Source IP, Source Port, Destination IP, and Destination Port fields, enter matching criteria for one or more connections.
- Step 6** Click **Trace** to display the connections that match the IP address and port criteria.

Connections are displayed in the Connection Tracing Results table below the fields. Use the filter settings in the Show drop-down list to filter the connections, as required. You can use Quick Filter to filter on any value or Show All Connections.

You can display flow distribution information from the CLI by using the **show appnav-controller flow-distribution EXEC** command.

Another troubleshooting tool that you can use to trace connections on a WAAS appliance AppNav cluster is the WAAS Tcptraceroute tool. For details, see [Using WAAS TCP Traceroute](#) in Chapter 16, “Troubleshooting Your WAAS Network.”

AppNav Connection Statistics

To view AppNav connection statistics in an AppNav-XE cluster, follow these steps:

- Step 1** From the WAAS Central Manager menu, choose **AppNav Clusters** > *cluster-name*.

- Step 2** Choose **Monitor > Tools > Connection Statistics**.
- Step 3** From the AppNav Controller drop-down list, choose the ANC from which you want to view statistics.
- Step 4** In the Source IP Address, Source Port, Destination IP Address, Destination Port, and Vrf Name fields, enter matching criteria for one or more connections.
- Step 5** Click **Submit** to display the connection statistics that match the IP address and port criteria.
- Connections are displayed in the Connection Statistics table below the fields. Use the filter settings in the Show drop-down list to filter the connections, as required. You can use Quick Filter to filter on any value or Show All Connections.
-

You can display connection statistics from the CLI by using the **show service-insertion statistics connection EXEC** command.



Configuring Traffic Interception

This chapter describes how to configure interception of TCP traffic in an IP-based network, based on the IP and TCP header information, and how to redirect the traffic to Cisco Wide Area Application Services (WAAS) devices. This chapter describes the use of the Web Cache Communication Protocol (WCCP), policy-based routing (PBR), inline mode for transparent redirection of traffic to Cisco Wide Area Application Engines (WAEs), appnav-controller mode for use with an AppNav Controller.



Note

Throughout this chapter, the term WAAS device is used to refer collectively to the WAAS Central Managers and WAEs in your network. The term WAE refers to WAE and Cisco Wide Area Virtualization Engine (WAVE) appliances, WAE Network Modules (the NME-WAE family of devices), SM-SRE modules running WAAS, and vWAAS instances.

Before you perform the procedures in this chapter:

- Complete a basic initial installation and configuration of your WAAS network, as described in the [Cisco Wide Area Application Services Quick Configuration Guide](#).
- For detailed command syntax information for any of the CLI commands in this chapter, see [Cisco Wide Area Application Services Command Reference](#).
- For more information about WCCP see the Cisco IOS documentation.

This chapter contains the following sections:

- [Overview of Traffic Interception Methods](#)
- [Overview of WCCP Interception](#)
- [Configuring Advanced WCCP Features on Routers](#)
- [Configuring WCCP on WAEs](#)
- [Using Policy-Based Routing Interception](#)
- [Using Inline Mode Interception](#)
- [Configuring AppNav Interception](#)

Overview of Traffic Interception Methods

This section contains the following topics:

- [About Traffic Interception Methods](#)
- [Guidelines for Configuring Traffic Interception](#)

About Traffic Interception Methods

In a WAAS network, traffic between clients in the branch offices and the servers in the data center can be redirected to WAEs for optimization, redundancy elimination, and compression. Traffic is transparently intercepted and redirected to WAEs based on policies that have been configured on the routers or on an AppNav Controller (ANC).

The network elements that transparently redirect requests to a local WAE can be a router using WCCP Version 2 or PBR to redirect traffic to the local WAE or a Layer 4 to Layer 7 switch, for example, the Catalyst 6500 series Content Switching Module (CSM) or Application Control Engine (ACE). Alternately, you can intercept traffic directly by using the inline mode with a WAE that has a Cisco WAE Inline Network Adapter or Interface Module.

When equipped with a Cisco AppNav Controller Interface Module, a WAVE appliance or cluster can intercept network traffic through WCCP or inline mode, and based on flow policies, distribute that traffic to one or more WAEs (WAAS nodes) for optimization.

[Table 5-1](#) summarizes the transparent traffic interception methods that are supported in your WAAS network.

Table 5-1 Supported Methods of Transparent Traffic Interception

Method	Description
WCCP Version 2	<p>Used for transparent interception of application traffic and Common Internet File System (SMB) traffic. Used in branch offices and data centers to transparently redirect traffic to the WAAS devices. The traffic is transparently intercepted and redirected to the local WAE or ANC by a WCCP-enabled router or a Layer 3 switch.</p> <p>You must configure WCCP on the router and WAE in the branch office and the router and WAE in the data center. For more information, see the following sections:</p> <ul style="list-style-type: none"> • Overview of WCCP Interception • Configuring Advanced WCCP Features on Routers • Configuring WCCP on WAEs
PBR	<p>Used in branch offices used for wide area application optimization. The branch office router is configured to use PBR to transparently intercept and route both client and server traffic to the WAE that resides in the same branch office.</p> <p>In data centers, used for data center application optimization. The data center router or Layer 3 switch can be configured to use PBR to transparently intercept and route client and server traffic to WAEs within the data center. PBR, however, does not support load balancing across multiple WAEs, such as WCCP does. PBR does not support load balancing when you use a hardware load balancer, such as the Cisco CSM or Cisco ACE. See Using Policy-Based Routing Interception.</p>
Inline	<p>The WAE physically and transparently intercepts traffic between the clients and the router. To use this mode, you must use a WAAS device with the Cisco WAE Inline Network Adapter, Cisco Interface Module, or Cisco AppNav Controller Interface Module. See Using Inline Mode Interception.</p>
vPATH	<p> Note WAAS versions 6.0 and above use either the WCCP or AppNav traffic interception methods. WAAS versions 5.5.1 and lower use WCCP, AppNav, or vPATH traffic interception methods.</p>

Table 5-1 Supported Methods of Transparent Traffic Interception (continued)

Method	Description
AppNav Controller	For WAEs that are part of an AppNav deployment and are configured as WAAS nodes in an AppNav Cluster, you must configure them to use the appnav-controller interception method. This configuration allows WAEs to receive and optimize traffic that is intercepted and distributed by the AppNav Controllers. See Configuring AppNav Interception .
ACE or CSM	Cisco Application Control Engine (ACE) or Catalyst 6500 series Content Switching Module (CSM) installed in the data center for data center application optimization. The ACE or CSM allows for both traffic interception and load balancing across multiple WAEs within the data center.

Guidelines for Configuring Traffic Interception

Note these guidelines when configuration traffic interception for your WAAS network:

- ISR-WAAS devices support only the AppNav Controller interception method.
- If a WAE device is behind a firewall that prevents traffic optimization, you can use the directed mode of communicating between peer WAEs over the WAN.
- Pass-through traffic does not benefit from optimization. For example, SSH port 22 has minimal traffic volume, so would not benefit by optimizing TCP flows.



Note If you use Microsoft System Center Configuration Manager with Preboot Execution Environment (SCCM/PXE), we recommend the following configurations for the ports that carry SCCM/PXE traffic: port 80, port 443, and port 445:

- port 80—Communicates with the distribution point. Configure for **pass-through traffic**.
- port 443—Communicates with the distribution point. Configure for **pass-through traffic**.
- port 445—Used for software package distribution data transfer. Configure for **traffic optimization**.

Without these configurations you may see the error message “PXE error code 80070056.”

Overview of WCCP Interception

The WAAS software uses the WCCP standard, Version 2, for redirection. The main features of WCCP Version 2 include support for the following:

- Up to 32 WAEs per WCCP service
- Up to 32 routers per WCCP service
- Authentication of protocol packets
- Redirection of non-HTTP traffic
- Packet return (including generic routing encapsulation [GRE], allowing a WAE to reject a redirected packet and to return it to the router to be forwarded)

- Masking for improved load balancing
- Multiple forwarding methods
- Packet distribution method negotiation within a service group
- Command and status interaction between the WAE and a service group

**Note**

WCCP works only with IPv4 networks.

WAAS software supports the WCCP TCP promiscuous mode service (services 61 and 62 by default, though these service IDs are configurable). This WCCP service requires that WCCP Version 2 is running on the router and the WAE.

The TCP promiscuous mode service is a WCCP service that intercepts all TCP traffic and redirects it to the local WAE.

The WAAS software also supports service passwords, WAE failover, and interception ACLs.

Many Cisco routers and switches can be configured and enabled with WCCP Version 2 support for use with WAAS devices.

Many legacy Cisco routers, including the 2500, 2600, and 3600 routers, have far less processing power and memory than newer routing platforms, such as the Integrated Services Router (ISR) models 2800 and 3800. As such, the use of WCCPv2 or PBR may cause a high level of CPU utilization on the router and cause erratic behavior. WAAS can be configured to work with these routers, but not to the same levels of performance or scalability as can be found with newer routing platforms. The Cisco ISR is the routing platform of choice for the branch office.

If you are experiencing erratic behavior, such as the WAE being ejected from the service group, enable fair queuing, weighted fair queuing, or rate limiting on all physical interfaces on the router that connect to users, servers, WAEs, and the WAN. Fair queuing cannot be configured on subinterfaces, and should be configured on both ingress and egress physical interfaces. If another form of queuing is already configured on the LAN or WAN interfaces other than fair queuing, and provides similar fairness, it should be sufficient.

Additionally, limit the amount of bandwidth that can be received on the LAN-side interface of the router, to help the router keep its interface queues less congested and provide better performance and lower CPU utilization. Set the maximum interface bandwidth on the router to no more than 10 times the WAN bandwidth capacity. For instance, if the WAN link is a T1, the LAN interface and WAE LAN interface bandwidth should be throttled to $10 * T1 = 10 * 1.544 \text{ Mbps}$, or approximately 15 Mbps. See the Cisco IOS documentation for more information.

This section contains the following topics:

- [Guidelines for Configuring WCCP](#)
- [Guidelines for File Server Access Methods](#)

Guidelines for Configuring WCCP

When you configure transparent redirection on a WAE using WCCP Version 2, follow these guidelines:

- Intercept and redirect packets on the inbound interface whenever possible.
- Use WCCP GRE or generic GRE as the egress method to place WAEs on the same VLAN or subnet as clients and servers. This topology is not allowed when using the IP forwarding egress method.
- Branch WAEs must not have their packets encrypted or compressed and should be part of the *inside* Network Address Translation (NAT) firewall if one is present.
- Use Layer 2 redirection as the packet forwarding method if you are using Catalyst 6500 series switches or Cisco 7600 Series Routers. Use Layer 3 GRE packet redirection if you are using any other Cisco router.
- When you configure WCCP for use with the Hot Standby Router Protocol (HSRP), you must configure the WAE with the HSRP or the Virtual Router Redundancy Protocol (VRRP) virtual router address as its default gateway, and the WAE WCCP router list with the primary address of the routers in the HSRP group.
- CEF is required for WCCP and must be enabled on the router.
- Place branch WAEs on the client side of the network to minimize client-side packets through the router.
- Use WCCP passwords to avoid denial-of-service attacks. For more information, see [Setting a Service Group Password on a Router](#).
- Use WCCP redirect lists for new implementations to limit client or server populations. For more information, see [Configuring IP Access Lists on a Router](#).
- Configure the WAE to accept redirected packets from one or more WCCP-enabled routers.
- To configure basic WCCP, enable the WCCP service on at least one router in your network and on the WAE or ANC that you want the traffic redirected to. It is not necessary to configure all the available WCCP features or services to get your WAE up and running. For an example of how to complete a basic WCCP configuration on routers and WAEs in a branch office and data center, see the [Cisco Wide Area Application Services Quick Configuration Guide](#).
- Configure the routers and WAEs to use WCCP Version 2 instead of WCCP Version 1 because WCCP Version 1 supports only web traffic (port 80).
- After enabling WCCP on the router, configure the TCP promiscuous mode service on the router and the WAE, as described in the [Cisco Wide Area Application Services Quick Configuration Guide](#). The service IDs are configurable on the WAE; you choose a pair of numbers that are different from the default of 61 and 62 to allow the router to support multiple WCCP farms because the WAEs in different farms can use different service IDs. The router configuration must use WCCP service IDs that match those configured on the WAEs in each farm it is supporting.
- For the WAE to function in TCP promiscuous mode, the WAE uses WCCP Version 2 services 61 and 62 (the service IDs are configurable). These two WCCP services are represented by the canonical name `tcp-promiscuous` on the WAE.
- Use CLI commands to configure basic WCCP on both the routers and the WAEs or ANCs. Alternatively, you can use CLI commands to configure the router for WCCP and use the WAAS Central Manager to configure basic WCCP on the WAEs or ANCs. In the configuration example provided in the [Cisco Wide Area Application Services Quick Configuration Guide](#), the `wccp` global configuration command is used to configure basic WCCP on the WAEs or ANCs.

We recommend that you use the WAAS CLI to complete the initial basic configuration of WCCP on your first branch WAE and data center WAE, as described in the [Cisco Wide Area Application Services Quick Configuration Guide](#). After you have verified that WCCP transparent redirection is working properly, you can use the WAAS Central Manager to modify this basic WCCP configuration or configure additional WCCP settings, for example, load balancing, for a WAE. For more information, see [Configuring WCCP on WAEs](#). After you have configured basic WCCP on the router, you can configure advanced WCCP features on the router, as described in [Configuring Advanced WCCP Features on Routers](#).

- To ensure consistency among WAEs, we recommend that you configure WCCP settings on one device and then use the **Copy Settings** taskbar icon from within the WCCP configuration window to copy the settings to other devices in your network. You should copy the settings only to the WAEs in the same WCCP service farm, AppNav Controller group (ANCG), or WAAS node group (WNG), because WCCP settings may have to be different in different farms or service groups.
- When you add a new router to an existing WCCP router farm or WCCP service group, the new router will reset existing connections. Until WCCP re-establishes path redirections and assignments, packets are sent directly to the client (as expected).
- The router must support the redirect and return methods configured on the WAE. If the router does not support the configured methods, the WAE will not join the WCCP router farm. If you have a mix of routers in the farm, only those routers that support the configured methods will join the farm.
- The WAE joins the WCCP farm only if the assignment method configured on the WAE is supported by the router. (The strict assignment method is always enforced with Version 4.4.1 and later.)
- A WAE joins a WCCP farm only if it is seen by all the configured routers in the farm. If there is a link failure in any one of the routers, the farm reconfigures, and the WAE is removed from the farm.
- All the WAEs in a WCCP farm must use the same pair of WCCP service IDs (the default is 61 and 62), and these IDs must match all the routers that are supporting the farm. A WAE with different WCCP service IDs is not allowed to join the farm, and an alarm is raised. Likewise, all the WAEs in a farm must use the same value for failure detection timeout. A WAE raises an alarm if you configure it with a mismatching value.
- Virtual routing and forwarding-aware (VRF) WCCP scalability is as follows:
 - The maximum number of WAEs supported by a single VRF instance is 32.
 - The maximum number of VRF instances supported by the router is router dependent.
 - VRF-aware WCCP is supported only on specific releases of Cisco IOS software. Ensure that the router is running a release of Cisco IOS software that supports VRF-aware WCCP.
 - Each VRF instance has independent assignment, redirection, and return methods.
- In a WAAS AppNav deployment, enable WCCP only on the ANC devices that are intercepting traffic and distributing it to the optimizing WAAS nodes (WNs). Configure WNs that are a part of the AppNav Cluster, with the appnav-controller interception method.
- To reduce the number of dropped packets in a network where WCCP L2 is deployed, we recommend that you configure the maximum segment size (MSS) to 1406 bytes on the WNs using the WAAS Central Manager. For more information on modifying MSS, see [Modifying the Acceleration TCP Settings](#) in Chapter 12, “Configuring Application Acceleration.”

Guidelines for File Server Access Methods

Some file servers have several network interfaces and can be reached through multiple IP addresses. For these server types, you must add all the available IP addresses to the branch WAE's WCCP accept list. This situation prevents a client from bypassing the branch WAE by using an unregistered IP address. The WAE Device Manager GUI displays all the IP addresses in the GUI.

Some file servers have several NetBIOS names and only one IP address. For these servers, if the client connects using the IP address in the UNC path (that is, \\IP_address\share instead of \\server\share), WAAS selects the first NetBIOS name from the server list in the WAE Device Manager GUI that matches this IP address. WAAS uses that name to perform NetBIOS negotiations between the data center WAE and the file server, and to create resources in the cache. If a file server uses multiple NetBIOS names to represent virtual servers (possibly with different configurations) and has one NetBIOS name that is identified as the primary server name, put that name in the server list before the other names.

Configuring Advanced WCCP Features on Routers

This section describes how to configure the advanced WCCP Version 2 features on a WCCP-enabled router that is transparently redirecting requests to WAEs in your WAAS network and contains the following topics:

- [Information About Configuring a Router to Support WCCP Service Groups](#)
- [Configuring IP Access Lists on a Router](#)
- [Setting a Service Group Password on a Router](#)
- [Configuring a Loopback Interface on the Router](#)
- [Configuring Router QoS for WCCP Control Packets](#)

**Note**

Before you perform the procedures in this section, you should have configured your router for basic WCCP as described in the [Cisco Wide Area Application Services Quick Configuration Guide](#).

Information About Configuring a Router to Support WCCP Service Groups

WCCP Version 2 enables a set of branch WAEs in a WAE or ANC group to connect to multiple routers. The WAEs in a group and the WCCP Version 2-enabled routers connected to the WAE group that are running the same WCCP service are known as a *service group*.

Through communication with the branch WAEs, the WCCP Version 2-enabled routers are aware of the available branch WAEs. Routers and branch WAEs become aware of one another and form a service group using WCCP Version 2. See [Figure 5-1](#).

In a WAAS AppNav deployment, only the ANCs are included in the service group. The routers do not send traffic directly to the optimizing WAEs (WNs); instead, ANCs distribute traffic within the WAAS network to the optimizing WNs.

Figure 5-1 Service Groups with WCCP Version 2

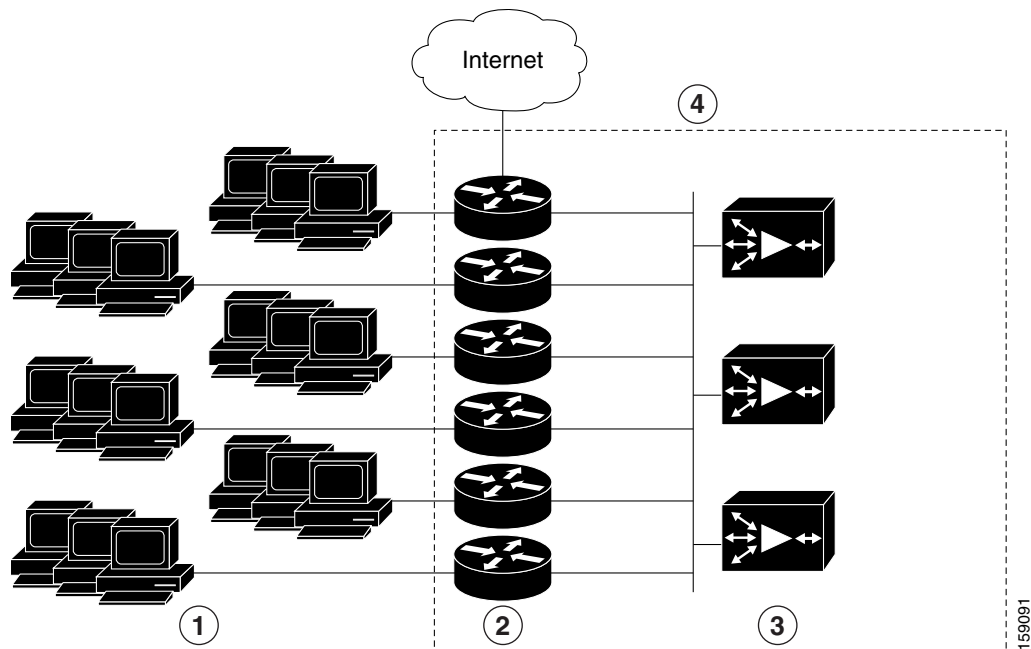

1	Clients requesting file services	3	Branch WAEs
2	Cisco routers	4	WAE service group

If you have a group of branch WAEs, the WAE that is seen by all the WCCP Version 2-enabled routers, and that has the lowest IP address, becomes the lead branch WAE.

The following procedure describes how a branch WAE in a service group is designated as the lead:

1. Each branch WAE is configured with a list of WCCP-enabled routers.

Multiple WCCP-enabled routers can service a group (up to 32 routers can be specified). Any of the available routers in a service group can redirect packets to each of the branch WAEs in the group.
2. Each branch WAE announces its presence to each router on the router list. The routers reply with their view of branch WAEs in the service group.
3. After the view is consistent across all of the branch WAEs in the group, one branch WAE is designated as the lead branch WAE and sets the policy that the WCCP-enabled routers need to deploy in redirecting packets.

The lead branch WAE determines how traffic should be allocated across the branch WAEs in the group. The assignment information is passed to the entire service group from the designated lead branch WAE so that the WCCP-enabled routers of the group can redirect the packets, and the branch WAEs in the group can better manage their load.

WCCP uses service groups to define WAAS services for a WCCP Version 2-enabled router and branch WAEs in a group. WCCP also redirects client requests to these groups in real time.

All the ports receiving redirected traffic that are configured as members of the same WCCP service group share the following characteristics:

- They have the same hash or mask parameters, as configured with the WAAS Central Manager ([Configuring or Viewing the WCCP Settings on WAEs](#)) or the WAAS CLI (the **wccp service-number mask** global configuration command).
- The WCCP Version 2 service on individual ports cannot be stopped or started individually (a WCCP Version 2 restriction).

Configuring IP Access Lists on a Router

You can optionally configure the router to redirect traffic from your WAE based on access control lists (ACLs) that you define on the router. These access lists are also referred to as redirect lists.



Note

We recommend that you use redirect lists on the WCCP-enabled router where possible, because that is the most efficient method to control traffic interception. However, you can also configure static bypass lists or interception ACLs on the WAEs, and of these two, we recommend that you use interception ACLs because they are more flexible and give better statistics about passed-through connections. For information about how to configure an interception ACL for a WAE, see [Configuring Interception Access Control Lists](#). For information about how to configure a static bypass list, see [Configuring Static Bypass Lists for WAEs](#). You can also configure interface ACLs on WAEs to control access to the WAE, as described in [Chapter 9, “Creating and Managing IP Access Control Lists for Cisco WAAS Devices.”](#)

Redirect lists that are configured on the routers have the highest priority, followed by static bypass lists or interception ACLs on WAEs. Interception ACLs that are configured on WAEs take precedence over application definition policies that have been defined on the WAE.

A WCCP Version 2-enabled router can be configured with access lists to permit or deny redirection of TCP traffic to a WAE. The following example shows that traffic conforming to the following criteria are not redirected by the router to the WAE:

- Originating from the host 10.1.1.1 destined for any other host
- Originating from any host destined for the host 10.255.1.1

```
Router(config)# ip wccp 61 redirect-list 120
Router(config)# ip wccp 62 redirect-list 120
Router(config)# access-list 120 deny ip host 10.1.1.1 any
Router(config)# access-list 120 deny ip any host 10.1.1.1
Router(config)# access-list 120 deny ip any host 10.255.1.1
Router(config)# access-list 120 deny ip host 10.255.1.1 any
Router(config)# access-list 120 permit ip any
```

Traffic that is not explicitly permitted is implicitly denied redirection. The **access-list 120 permit ip any** command explicitly permits all traffic (from any source on the way to any destination) to be redirected to the WAE. Because criteria matching occurs in the order in which the commands are entered, the global **permit** command is the last command entered.

To limit the redirection of packets to those packets matching an access list, use the **ip wccp redirect-list** global configuration command. Use this command to specify which packets should be redirected to the WAE.

When WCCP is enabled, but the **ip wccp redirect-list** command is not used, all the packets matching the criteria of a WCCP service are redirected to the WAE. When you specify the **ip wccp redirect-list** command, only packets that match the access list are redirected.

The **ip wccp** global configuration command and the **ip wccp redirect** interface configuration command are the only commands required to start redirecting requests to the WAE using WCCP. To instruct an interface on the WCCP-enabled router to check for appropriate outgoing packets and redirect them to a WAE, use the **ip wccp redirect** interface configuration command. If the **ip wccp** command is enabled, but the **ip wccp redirect** command is disabled, the WCCP-enabled router is aware of the WAE, but does not use it.

To specify the access list by name or number, use the **ip wccp group-list** global configuration command, which defines criteria for group membership. In the following example, the **access-list 1 permit 10.10.10.1** command is used to define the IP address of the WAE that is allowed to join the WCCP service group:

```
Router(config)# ip wccp 61 group-list 1
Router(config)# ip wccp 62 group-list 1
Router(config)# access-list 1 permit 10.10.10.1
```

**Tip**

If you have a WCCP service farm with multiple WAEs, the load-balancing assignment may cause packets that are sent to the WAE devices themselves (such as management traffic) to be redirected to a different WAE in the farm, negatively impacting performance. To avoid this situation, we recommend that you configure a WCCP redirect list that excludes traffic that is sent to the WAE IP addresses from being redirected.

For more information on access lists, see the Cisco IOS IP addressing and services documentation.

Setting a Service Group Password on a Router

For security purposes, you can set a service password for your WCCP Version 2-enabled router and the WAEs that access it. Only devices configured with the correct password are allowed to participate in the WCCP service group.

From the global configuration mode of your WCCP-enabled router, enter the following commands to specify the service group password for the TCP promiscuous mode service on the router (the service IDs must match the service IDs configured on the WAE):

```
Router(config)# ip wccp 61 password [0-7] password
Router(config)# ip wccp 62 password [0-7] password
```

The required *password* argument is the string that directs the WCCP Version 2-enabled router to apply MD5 authentication to messages received from the specified service group. Messages that are not accepted by the authentication are discarded. *0-7* is the optional value that indicates the HMAC MD5 algorithm used to encrypt the password. This value is generated when an encrypted password is created for the WAE. *7* is the recommended value. The optional *password* argument is the optional password name that is combined with the HMAC MD5 value to create security for the connection between the router and the WAE.

For information about how to use the WAAS Central Manager to specify the service group password on a WAE, see [Configuring or Viewing the WCCP Settings on WAEs](#).

Configuring a Loopback Interface on the Router

The highest IP address among the router's loopback interfaces is used to identify the router to the WAEs.

The following example configures the loopback interface, exits configuration mode, and saves the running configuration to the startup configuration:

```
Router(config)# interface Loopback0
Router(config-if)# ip address 111.111.111.111 255.255.255.0
Router(config-if)# no shutdown
Router(config-if)# end
Router# copy running-config startup-config
```

Configuring Router QoS for WCCP Control Packets

WAAS sends WCCP control packets marked with a differentiated services code point (DSCP) value of 192. (In WAAS versions earlier than 4.2, packets were unmarked.) For a router to honor this priority value, you must configure the router's multilayer switching (MLS) quality of service (QoS) port trust state and classify traffic by examining the DSCP value. To configure the router appropriately, use the `mls qos trust dscp` command in interface configuration mode on the interface connected to the WAE.

Configuring WCCP on WAEs

This section contains the following topics:

- [Information About Load Balancing and WAEs](#)
- [Information About Packet-Forwarding Methods](#)
- [Configuring or Viewing the WCCP Settings on WAEs](#)
- [Configuring or Viewing the WCCP Settings on ANCs](#)
- [Configuring and Viewing WCCP Router Lists for WAEs](#)
- [Configuring WAEs for a Graceful Shutdown of WCCP](#)
- [Configuring Static Bypass Lists for WAEs](#)
- [Configuring Interception Access Control Lists](#)
- [Configuring Egress Methods for WCCP-Intercepted Connections](#)



Note

Before you perform the procedures in this section, you should have completed an initial configuration of your WAAS network, which includes the basic configuration of WCCP Version 2 and the TCP promiscuous mode service on your routers and WAEs, as described in the [Cisco Wide Area Application Services Quick Configuration Guide](#).

Information About Load Balancing and WAEs

Multiple WAEs with WCCP support can be deployed for dynamic load balancing to enable adjustments to the loads being forwarded to the individual WAEs in a service group. IP packets received by a WCCP-enabled router are examined to determine if it is a request that should be directed to a WAE. Packet examination involves matching the request to a defined service criteria. These packets are passed to the processing routine on the router to determine which WAE, if any, should receive the redirected packets.

**Note**

In a WAAS AppNav deployment, only ANC's are included in the service group and are load balanced by the routers. The routers do not send traffic to the optimizing WAEs (WNGs); instead, ANC's distribute traffic to the optimizing WNGs.

You can use load balancing to balance the traffic load across multiple WAEs. Load balancing allows the set of hash address buckets assigned to a WAE to be adjusted, shifting the load from an overwhelmed WAE to other WAEs that have available capacity. Two assignment methods are used by this technique: hashing and masking.

Assignment method denotes the method used by WCCP to perform load distribution across WAEs. The two possible load-balancing assignment methods are hashing and masking. If the mask load-balancing method is not specified, then the hash load-balancing method, which is the default method, is used.

**Note**

In a WAAS AppNav deployment, only the mask assignment method is supported and is the default.

WCCP supports redirection based on a hash function. The hash key may be based on the source or destination IP address of the packet. For WAAS, load-balancing hashing is based on a source IP address (default), a destination IP address, or both.

The hash function uses the source IP address to obtain an address bucket to which the packet is assigned. These source address buckets are then mapped to a particular WAE depending on how many WAEs are present and how busy they are. (See [Figure 5-2](#).)

Figure 5-2 Load Balancing Through Hashing of IP Addresses

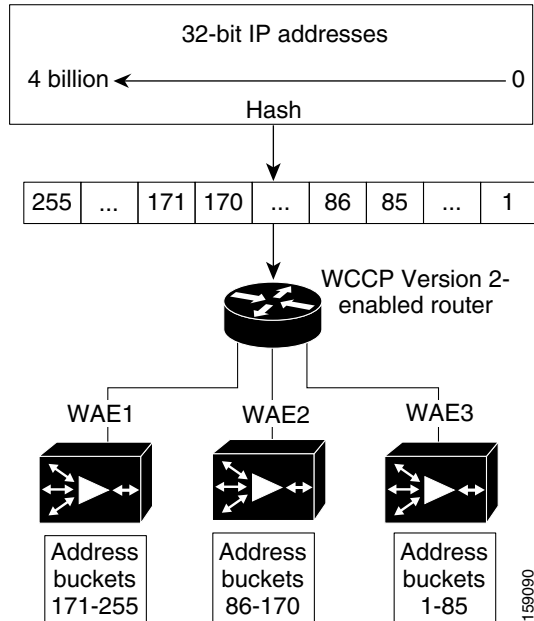
**Note**

Packets that the WAEs do not service are tunneled back to the same router from which they were received. When a router receives a formerly redirected packet, it knows that it should not redirect it again.

Destination IP address hashing guarantees that a single WAE caches a given file server. This method, which allows a local coherency directive to be safely applied to the file server content (provided that no other collaboration on the content occurs), improves performance and WAN link and disk utilization. This method may distribute the load unevenly because of uneven activity on a file server.

Source IP address hashing has better potential for session distribution between the caches on branch WAEs. This method may impact performance and WAN link and disk utilization (see the previous description of factors to be aware of when load balancing is applied). Also, any change in the IP address of a client (which can happen when working in DHCP environments) may cause the client to switch to another branch WAE, which can cause the client to experience reduced performance until the client's working set is retrieved into the new cache.

Hashing that is based on a client IP address does not guarantee any locality of the hash key. For example, clients from the same subnet (which are likely to share and collaborate on the same content) may be assigned two different hash numbers and may be redirected to different branch WAEs, while clients from different subnets may be assigned the same hash number and may be redirected to the same branch WAE. Hashing that is based on a client IP address does guarantee consistency. For example, a client using the same IP address is redirected to the same branch WAE.

In the service farm, a lead WAE is chosen to build the hash table that distributes the load between the available WAEs. The lead WAE distributes the buckets evenly. The source IP address is hashed and the resulting bucket determines the WAE that will handle the packet.

WCCP supports redirection by mask value assignments. This method relies on masking to make redirection decisions. The decisions are made using special hardware support in the WCCP-enabled router. This method can be very efficient because packets are switched by the hardware.

**Note**

The masking method can only be used for load balancing with the Catalyst 3750, Catalyst 4500, and Catalyst 6500 Series Switches, Cisco 7600 Series Routers, and Cisco ASR 1000 Aggregation Series Routers. And, the masking method can be used with the Cisco 2800, 3800, and 7200 Series Routers when they are running Cisco IOS Release 12.4(20)T or later releases.

You must explicitly specify masking. You can specify two mask values based on the source or destination IP address of the packet. For WAAS, the default mask value is based on the source IP address. You can enable masks by using the default values or specifying a particular mask. The default mask values, specified in hexadecimal notation, are as follows:

- `dst-ip-mask= 0x0`
- `src-ip-mask= 0xF00`

You can specify the mask value with a maximum of seven bits. The WAE creates a table of the 2^7 (or 128) combinations, assigns the WAE IP addresses to them, and sends this table to a WCCP-enabled router. The router uses this table to distribute the traffic among all the WAEs that are in the service group. Each packet that matches the WCCP service parameters is compared to this table and the packets are sent to the matching WAE.

In a service farm where the WAEs have different masks, the first WAE to establish two-way communication with the routers determines the farm's mask. All the other WAEs cannot join the farm unless they are configured with the same mask.

Masking is typically used at the data center, where you can take advantage of the hardware-accelerated WCCP redirection capabilities of switches, such as the Catalyst 6500 Series Switches. At the data center, the load balancing goal should be to have all the connections originating from a given client subnet (typically equivalent to a branch) go to one data center WAE, in order to improve data redundancy elimination (DRE) compression performance. Also, mask assignment on the Catalyst 6500 series

switches uses the ACL Ternary Content Adjustable Memory (TCAM). When combined with WCCP redirect lists, mask assignment can use a large portion of the TCAM. To minimize TCAM usage, use a mask with fewer care bits.

Given these considerations, beginning with WAAS Version 4.2.1, the default mask has been changed from `src-ip-mask 0x1741` and `dst-ip-mask 0x0` (in 4.1x versions) to `src-ip-mask 0xF00` and `dst-ip-mask 0x0` (in 4.2.1 and later versions). The current source IP mask uses only four care bits rather than the six care bits used by the old mask.

With a typical data center WCCP interception configuration (ingress interception with service 61 on the WAN, ingress interception with service 62 on the LAN), this mask load balances /24 branch subnets (it extracts the last 4 bits of /24 subnets). Connections from one branch subnet will be pinned to one data center WAE. If your network has a different distribution of IP addresses, for example, /16 subnets, you should configure a mask that extracts bits from the /16 network part of the address, for example, `src-ip-mask 0xF0000`. Similarly, if some branches generate more traffic than others, you may want to create a mask that also extracts bits from the host part of the address, for example, `0xF03`.

Information About Packet-Forwarding Methods

A WCCP-enabled router redirects intercepted TCP segments to a WAE using one of the following two packet-forwarding methods:

- Generic routing encapsulation (GRE)—Allows packets to reach the WAE, irrespective of the number of routers in the path to the WAE.
- Layer 2 redirection—Allows packets to be switched at Layer 2 (MAC layer) and reach the WAE.

Table 5-2 describes the packet-forwarding methods.

Table 5-2 Packet-Forwarding Methods

Packet-Forwarding Method	Load-Balancing Method: Hashing	Load-Balancing Method: Masking
GRE (Layer 3)	Packet redirection is completely handled by the router software.	Packet redirection is handled by the router software. We do not recommend the use of mask assignment when GRE is being used as the packet-forwarding method.
Layer 2 redirection	First redirected packet is handled by the router software; all subsequent redirected packets are handled by the router hardware.	All the packets are handled by the router hardware (currently supported only on the Catalyst 6500 Series Switches or Cisco 7600 Series Routers because special hardware is required).

The redirection mode is controlled by the branch WAE. The first branch WAE that joins the WCCP service group decides the forwarding method (GRE or Layer 2 redirection) and the assignment method (hashing or masking). The term *mask assignment* refers to WCCP Layer 2 Policy Feature Card 2 (PFC2) input redirection.

If masking is selected with WCCP output redirection, the branch WAE falls back to the original hardware acceleration that is used with the Multilayer Switch Feature Card (MSFC) and the Policy Feature Card (PFC).

For example, WCCP filters the packets to determine which redirected packets have been returned from the branch WAE and which ones have not. WCCP does not redirect the ones that have been returned because the branch WAE has determined that the packets should not be processed. WCCP Version 2 returns the packets that the branch WAE does not service to the same router from which they were transmitted.

This section contains the following topics:

- [Reasons for Packet Rejection and Return](#)
- [Layer 3 GRE as a Packet-Forwarding Method](#)
- [Layer 2 Redirection as a Packet-Forwarding Method](#)

Reasons for Packet Rejection and Return

A branch WAE rejects packets and initiates packet return for the following reasons:

- The WAE is filtering out certain conditions that make processing packets unproductive, for example, when IP authentication has been turned on.
- You have configured a static bypass list or interception ACL on the branch WAE.



Note

The packets are redirected to the source of the connection between the WCCP-enabled router and the branch WAE. Depending on the Cisco IOS software version used, this source could be either the address of the outgoing interface or the router IP address. In the latter case, it is important that the branch WAE has the IP address of the WCCP-enabled router stored in the router list. For more information on router lists, see [Configuring and Viewing WCCP Router Lists for WAEs](#).

Cisco Express Forwarding (CEF) is required for WCCP and must be enabled on the router.

WCCP also allows you to configure multiple routers in a router list to support a particular WCCP service (for example, SMB redirection).

Layer 3 GRE as a Packet-Forwarding Method

A WCCP-enabled router redirects intercepted requests to a WAE, and can encapsulate packets using GRE. This method of forwarding packets allows packets to reach the WAE even if there are routers in the path to the WAE. Packet redirection is handled entirely by the router software.

GRE allows datagrams to be encapsulated into IP packets at the WCCP-enabled router and then redirected to a WAE (the transparent proxy server). At this intermediate destination, the datagrams are decapsulated and then handled by the WAAS software. If the request cannot be handled locally, the origin server may be contacted by the associated WAE to complete the request. In doing so, the trip to the origin server appears to the inner datagrams as one hop. The redirected traffic using GRE is usually referred to as GRE tunnel traffic. With GRE, all redirection is handled by the router software.

With WCCP redirection, a Cisco router does not forward the TCP SYN packet to the destination because the router has WCCP enabled on the destination port of the connection. Instead, the WCCP-enabled router encapsulates the packet using GRE tunneling and sends it to the WAE that has been configured to accept redirected packets from this WCCP-enabled router.

After receiving the redirected packet, the WAE performs the following tasks:

1. Strips the GRE layer from the packet.
2. Decides whether it should accept this redirected packet and process the request for content or deny the redirected packet as follows:

- If the WAE decides to accept the request, it sends a TCP SYN ACK packet to the client. In this response packet, the WAE uses the IP address of the original destination (origin server) that was specified as the source address so that the WAE can be invisible (transparent) to the client; it pretends to be the destination that the TCP SYN packet from the client was trying to reach.
- If the WAE decides not to accept the request, it re-encapsulates the TCP SYN packet in GRE, and sends it back to the WCCP-enabled router. The router understands that the WAE is not interested in this connection and forwards the packet to its original destination (that is, the origin server).

Layer 2 Redirection as a Packet-Forwarding Method

Layer 2 redirection is accomplished when a WCCP-enabled router or switch takes advantage of internal switching hardware that either partially or fully implements the WCCP traffic interception and redirection functions at Layer 2. This type of redirection is currently supported only with the Catalyst 6500 Series Switches and Cisco 7200 and 7600 Series Routers. With Layer 2 redirection, the first redirected traffic packet is handled by the router software. The rest of the traffic is handled by the router hardware. The branch WAE instructs the router or switch to apply a bit mask to certain packet fields, which in turn provides a mask result or index mapped to the branch WAE in the service group in the form of a mask index address table. The redirection process is accelerated in the switching hardware, making Layer 2 redirection more efficient than Layer 3 GRE.



Note

WCCP is licensed only on the WAE and not on the redirecting router. WCCP does not interfere with normal router or switch operations.

Configuring or Viewing the WCCP Settings on WAEs

This section describes how to configure or view WCCP settings on WAEs that are configured as application accelerators and are not part of an AppNav Cluster (WAEs that are part of an AppNav Cluster use only the appnav-controller interception method). To configure or view the WCCP settings on WAEs configured as AppNav Controllers, see [Configuring or Viewing the WCCP Settings on ANCs](#).

Device group configuration is not possible beginning with WAAS version 5.0. However, you can use the **Copy Settings** taskbar icon in the configuration window to copy the settings to other devices in your network. To ensure consistency, we recommend that you copy the same WCCP settings to all devices in the same WCCP service farm.



Note

Before you perform the procedure in this section, you should have already completed a basic WCCP configuration for your WAAS network that includes the configuration of the TCP promiscuous mode service, as described in the [Cisco Wide Area Application Services Quick Configuration Guide](#).

To modify the WCCP settings for a WAE, follow these steps:

- Step 1** From the WAAS Central Manager menu, choose **Devices** > *device-name*.
- Step 2** Choose **Configure** > **Interception** > **Interception Configuration**. The Interception Configuration window appears. (See [Figure 5-3](#).)

**Note**

If you are configuring a device using a WAAS version earlier than 5.0, choose **Configure > Interception > WCCP > Settings** to configure WCCP settings. The configuration window looks different, but has similar settings.

Figure 5-3 Interception Configuration Window for WAE

The screenshot displays the Cisco Wide Area Application Services (WAAS) configuration interface for WCCP settings. The top navigation bar includes 'Home', 'Device Groups', 'Devices', 'AppNav Clusters', and 'Locations'. The current device is 'wae-231-02'. The configuration path is 'wae-231-02 > Configure > Interception > Interception Configuration'. The 'Interception Method Settings' section shows 'Interception Method' set to 'wccp'. The 'WCCP Settings' section includes 'Enable WCCP Service' (unchecked), 'Service Type' set to 'TCP Promiscuous', 'Service ID1' set to '61' (range 1-99), and 'Service ID2' set to '62' (range 2-100). There is an option to 'Use Default Gateway as WCCP Router' (unchecked) and a field for 'WCCP Routers'. The 'WCCP Assignment Settings for Load Balancing' section shows 'Assignment Method' set to 'Mask', 'Source IP Mask' set to 'f00' (Hex String), and 'Destination IP Mask' set to '0' (Hex String). The 'WCCP Redirect and Egress Settings' section shows 'Redirect Method' set to 'WCCP L2' and 'Egress Method' set to 'L2'. The 'Advanced WCCP Settings' section includes 'Enable Flow Protection' (unchecked), 'Flow Protection Timeout' set to '0' (0-86400) seconds, 'Shutdown Delay' set to '120' (0-86400) seconds, 'Failure Detection Timeout' set to '30', 'Weight' set to '0' (0-10000), and fields for 'Password' and 'Confirm Password'. A note at the bottom states: 'Disabling WCCP and/or changing Service ID values from Central Manager terminates existing WCCP connection(s) immediately. If graceful shutdown is required please use CLI.' The window has 'Submit' and 'Reset' buttons at the bottom left and an 'Alarms' indicator at the bottom right.

Step 3 Check the current settings for the chosen device:

- To keep the current settings and to close the window, click **Reset**.
- To remove the current settings, click the **Remove Settings** taskbar icon.
- To modify the current settings, change the current setting, as described in the rest of this procedure.
- To copy the settings to other WAEs in your network, click the **Copy Settings** taskbar icon. The Copy Interception Settings window opens, where you can select other WAEs to which the interception settings can be copied. You can copy all the settings or you can exclude the router list and enable the WCCP service. Click **OK** to copy the settings to the selected WAEs devices.

By default, WCCP is disabled on a WAE. However, as part of the initial configuration of WCCP in your WAAS network, you should have enabled WCCP Version 2 on your WAEs (the branch WAE and the data center WAE) as well as on the routers in the data center and branch office that will be transparently redirecting requests to these WAEs. For information about how to perform a basic WCCP configuration in your WAAS network, see the [Cisco Wide Area Application Services Quick Configuration Guide](#).

- Step 4** From the Interception Method drop-down list, choose **wccp** to enable the WCCP interception method. If you change this setting from any setting other than None, click **Submit** to update the window with the proper fields for configuring WCCP. (The Interception Method drop-down list is not displayed for devices using WAAS versions earlier than 5.0.)
- Step 5** Check the **Enable WCCP Service** check box to enable WCCP Version 2 on the chosen device, or uncheck the check box to disable WCCP on the chosen device.



Note Ensure that the routers used in the WCCP environment are running a version of the Cisco IOS software that also supports the WCCP Version 2.



Note If you use the Central Manager to disable WCCP on a WAAS device, the Central Manager immediately shuts down WCCP and closes any existing connections, ignoring the setting configured by the **wccp shutdown max-wait** global configuration command. To gracefully shut down WCCP connections, use the **no enable WCCP** configuration command on the WAAS device.

- Step 6** In the Service ID1 field, specify the first service ID of the WCCP service pair. After you submit, the Service ID2 field is filled in with the second service ID of the pair, which is one greater than Service ID1. For WAEs with Version 4.4.1 or later, you can change the WCCP service IDs from the default of 61/62 to a different pair of numbers, which allows a router to support multiple WCCP farms because the WAEs in different farms can use different service IDs. (The Service ID fields are not shown for devices using WAAS versions earlier than 4.4 and the service IDs are fixed at 61/21.)

The router service priority varies inversely with the service ID. The service priority of the default service IDs 61/62 is 34. If you specify a lower service ID, the service priority is higher than 34; if you specify a higher service ID, the service priority is lower than 34.

- Step 7** Check the **Use Default Gateway as WCCP Router** check box to use the default gateway of the WAE device as the router to associate with the WCCP TCP promiscuous mode service. Alternatively, uncheck this check box and specify a list of one or more routers by their IP addresses, separated by spaces. The Central Manager assigns the router list number, which is displayed next to the router list field after the page is submitted. As part of the initial configuration of your WAAS network, you may have already created a WCCP router list with the setup utility, as described in the [Cisco Wide Area Application Services Quick Configuration Guide](#). For more information about WCCP router lists, see [Configuring and Viewing WCCP Router Lists for WAEs](#).



Note Checking or unchecking the **Use Default Gateway as WCCP Router** check box, changing the router list, or submitting the WCCP page removes existing router lists, if any, that are not assigned to the WCCP service, including router lists configured by the setup utility or through the CLI.

- Step 8** (Optional) To force WCCP to use only the configured assignment method, check the **Only Use Selected Assignment Method** check box. You can specify only one load-balancing method (hashing or masking) per WCCP service in a branch WAE service group. (This check box is shown only for devices using WAAS versions earlier than 4.4.)

**Note**

If you check the **Only Use Selected Assignment Method** check box, the WAE only joins a WCCP farm if the assignment method configured on the WAE is supported by the router. If you do not check the **Only Use Selected Assignment Method** check box, the WAE uses the assignment method that the router supports, even if the WAE is configured differently from the router.

- Step 9** (Optional) From the Assignment Method drop-down list, choose the type of WAE load-balancing assignment method to use:
- Choose **Hash** to use the hash method (the default for devices using WAAS versions earlier than 5.0). Perform [Step 10](#) and [Step 11](#) to define how the hash works, and skip to [Step 13](#) because the mask settings are not used.
 - Choose **Mask** to use the mask method (the default for devices using WAAS versions 5.0 or later). Skip to [Step 12](#) to define the service mask.

For more information, see [Information About Load Balancing and WAEs](#).

- Step 10** (Optional) To define the load-balancing hash for WCCP service ID1 on the source IP address, check the **Hash on Source IP** check box. This check box is shown only if the hash assignment method is used.
- Step 11** (Optional) To define the load-balancing hash for WCCP service ID1 on the destination IP address, check the **Hash on Destination IP** check box. This check box is shown only if the hash assignment method is used.
- Step 12** (Optional) To use a custom service mask, enter different mask values in the WCCP Assignment Settings for Load Balancing area, overwriting the default mask settings. If you do not change these settings, the defaults are used. Define the custom mask as follows:
- In the Source IP Mask field, specify the IP address mask defined by a hexadecimal number, for example, FE000000, used to match the packet source IP address. The range is 00000000 to FE000000. The default is F00.
 - In the Destination IP Mask field, specify the IP address mask defined by a hexadecimal number, for example, FE000000, used to match the packet destination IP address. The range is 00000000 to FE000000. The default is 0.

**Note**

If you apply the default mask to a WAE running WAAS Version 4.1.x or earlier, the mask is different from the default mask (0x1741) set under WAAS Version 4.1.x and earlier.

If the WAE detects that its configured mask is not the same as that advertised by one or more routers in the farm, it is not allowed to join the farm, and a major alarm is raised (**configured mask mismatch for wccp**). This alarm can occur when a WAE is trying to join a farm that already has other WAEs, and these other WAEs are configured with a different mask. The routers do not allow other WAEs to join the farm unless they advertise the same mask. To correct this alarm, ensure that all the WAEs in the farm are configured with the same mask. This alarm is cleared when the WAE's configured mask matches the mask of all the routers in the farm.

- Step 13** From the Redirect Method drop-down list, choose the type of packet redirection (forwarding) method to use:
- **WCCP GRE** (the default for devices using WAAS versions earlier than 5.0) to use Layer 3 GRE packet redirection.
 - **WCCP L2** (the default for devices using WAAS versions 5.0 or later) to permit the WAE to receive transparently redirected traffic from a WCCP Version 2-enabled switch or router if the WAE has a Layer 2 connection with the device and the device is configured for Layer 2 redirection. For more

information, see [Information About Packet-Forwarding Methods](#).



Note Do not use WCCP L2 redirection on an ISR-WAAS device when ip unnumbered is configured on the host router VirtualPortGroup interface. The device will not be able to join the WCCP farm and the missing_assignment alarm will be raised.

Step 14 From the Return Method drop-down list, choose the type of method to use to return nonoptimized (bypassed) packets to the router:

- WCCP GRE (the default) to use GRE packet return.
- WCCP L2 to use Layer 2 rewriting for packet return.

The Return Method drop-down list is shown only for devices using WAAS versions earlier than 5.0. For WAAS Version 5.1, the return method is set the same as the redirect method. For WAAS Version 5.2 and later, the return method is automatically negotiated with router to the same as the redirect method if the router supports it. If the router does not support the return method that matches the redirect method, then the return method is set to the return method supported by the router. For example, if the redirect method is set to WCCP L2, but the router supports only the GRE return method, then the return method is set to WCCP GRE.

Step 15 (Optional) From the Egress Method drop-down list, choose the method to use to return optimized packets to the router or switch:

- Generic GRE (available and set as the default only if Redirect Method is WCCP GRE)
- IP Forwarding
- L2 (available and set as the default only if Redirect Method is WCCP L2)
- WCCP GRE (available only if Redirect Method is WCCP GRE)

For devices using WAAS versions earlier than 5.0, the choices are as follows: IP Forwarding (the default), WCCP Negotiated Return, or Generic GRE. For more details on choosing the egress method, see [Configuring Egress Methods for WCCP-Intercepted Connections](#).

Step 16 (Optional) Modify the current advanced settings in the Advanced WCCP Settings area as follows:

- Check the **Enable Flow Protection** check box to keep the TCP flow intact and to avoid overwhelming the device when it comes up or is reassigned new traffic. Flow protection is disabled by default.
- In the Flow Protection Timeout field, specify the amount of time (in seconds) that flow protection should be enabled. The default is 0, which means it stays enabled with no timeout. (The Flow Protection Timeout field is not shown for devices using WAAS versions earlier than 5.0.)



Note The **Enable Flow Protection** check box and the **Flow Protection Timeout** field are not enabled on WAAS v6.0.1.

- In the Shutdown Delay field, specify the maximum amount of time (in seconds) that the chosen device waits to perform a clean shutdown of WCCP. The default is 120 seconds.

The WAE does not reboot until either all connections have been serviced or the maximum wait time (specified through this Shutdown Delay field) has elapsed for WCCP.

- From the Failure Detection Timeout drop-down list, choose the failure detection timeout value (9, 15, or 30 seconds). The default is 30 seconds and is the only value supported on WAAS versions prior to 4.4.1. This failure detection value determines how long it takes the router to detect a WAE failure. (The Failure Detection Timeout field is not shown for devices using WAAS versions earlier than 4.4.)

The failure detection timeout value is negotiated with the router and takes effect only if the router also has the variable timeout capability. If the router has a fixed timeout of 30 seconds and you have configured a failure detection value on the WAE other than the default 30 seconds, the WAE is not able to join the farm and an alarm is raised (**Router unusable** with a reason of **Timer interval mismatch with router**).

- In the Weight field, specify the weight value that is used for load balancing. The weight value ranges from 0 to 10000. If the total of all the weight values of the WAEs in a service group is less than or equal to 100, then the weight value represents a literal percentage of the total load redirected to the device for load-balancing purposes. For example, a WAE with a weight of 10 receives 10 percent of the total load in a service group where the total of all the weight values is 50. If a WAE in such a service group fails, the other WAEs still receive the same load percentages as before the failure; they will not receive the load allocated to the failed WAE.

If the total of all the weight values of the WAEs in a service group is between 101 and 10000, then the weight value is treated as a fraction of the total weight of all the active WAEs in the service group. For example, a WAE with a weight of 200 receives 25 percent of the total load in a service group where the total of all the weight values is 800. If a WAE in such a service group fails, the other WAEs will receive the load previously allocated to the failed WAE. The failover handling is different than if the total weights are less than or equal to 100.

By default, weights are not assigned and the traffic load is distributed evenly between the WAEs in a service group.

- In the Password field, specify the password to be used for secure traffic between the WAEs within a cluster and the router for a specified service. Be sure to enable all other WAEs and routers within the cluster with the same password. Passwords must not exceed eight characters in length. Do not use the following characters: space, backwards single quote ('), double quote ("), pipe (|), or question mark (?). Re-enter the password in the Confirm Password field.



Note For information about how to use the CLI to specify the service group password on a router, see [Setting a Service Group Password on a Router](#).

Step 17 Click **Submit** to save the settings.

To configure WCCP settings from the CLI, you must first set the interception method to WCCP by using the **interception-method** global configuration command, after which you can use the **wccp router-list**, **wccp shutdown**, and **wccp tcp-promiscuous** global configuration commands.

For more information about a graceful shut down of WCCP Version 2 on WAEs, see [Configuring WAEs for a Graceful Shutdown of WCCP](#).

Configuring or Viewing the WCCP Settings on ANCs

This section describes how to configure or view WCCP settings on WAAS devices configured as AppNav Controllers (ANCs). Typically, you configure ANCs and their settings through the AppNav Clusters window in the Central Manager, which includes WCCP settings. Therefore, you do not have to configure the WCCP settings outside the AppNav Cluster context, as described in this section.

To configure or view the WCCP settings on WAEs configured as application accelerators, see [Configuring or Viewing the WCCP Settings on WAEs](#). To configure interception settings on WAEs operating as WAAS nodes for an AppNav Controller, see [Configuring AppNav Interception](#).

Device group configuration is not possible beginning with WAAS Version 5.0. However, you can use the **Copy Settings** taskbar icon in the configuration window to copy the settings to other devices in your network. To ensure consistency, we recommend that you copy the same WCCP settings to all the devices in the same WCCP service farm.

To modify the WCCP settings for an ANC, follow these steps:

-
- Step 1** From the WAAS Central Manager menu, choose **Devices** > *device-name*.
- Step 2** Choose **Configure** > **Interception** > **Interception Configuration**. The Interception Configuration window appears. (See [Figure 5-3](#).)

Figure 5-4 Interception Configuration Window for ANC

The screenshot displays the 'Interception Configuration' window for device WAE-231-03. The breadcrumb trail is 'Devices > WAE-231-03 > Configure > Interception > Interception Configuration'. The 'Interception Method' is set to 'wccp'. Under 'WCCP Settings', 'Enable WCCP Service' is checked, 'Service Type' is 'TCP Promiscuous', and 'Enable Single Service Mode' is unchecked. 'Service ID1' is 61 and 'Service ID2' is 62. 'Use Default Gateway as WCCP Router' is unchecked. The 'WCCP Routers' field is empty. Under 'WCCP Assignment Settings for Load Balancing', 'Source IP Mask' is 'f' and 'Destination IP Mask' is '0'. Under 'Advanced WCCP Settings', 'Redirect Method' is 'WCCP L2', 'Failure Detection Timeout' is 30, and 'Weight' is 0. There are empty fields for 'Password' and 'Confirm Password'. 'Submit' and 'Reset' buttons are at the bottom. The top right shows 'admin | Logout | Help' and the bottom right shows 'Alarms 2 1 0' and '346135'.

- Step 3** Check the current settings for the chosen device:

- To keep the current settings and to close the window, click **Reset**.
- To remove the current settings, click the **Remove Settings** taskbar icon.
- To modify the current settings, change the current setting, as described in the rest of this procedure.
- To copy the settings to other WAEs in your network, click the **Copy Settings** taskbar icon. The Copy Interception Settings window opens, where you can select other WAEs to which the interception settings can be copied. You can copy all the settings or you can exclude the router list and enable the WCCP service. Click **OK** to copy the settings to the selected WAEs devices.

By default, WCCP is disabled on a WAE. However, as part of the initial configuration of WCCP in your WAAS network, you should have enabled WCCP Version 2 on your WAEs (the branch WAE and the data center WAE) as well as on the routers in the data center and branch office that will be transparently redirecting requests to these WAEs. For information about how to perform a basic WCCP configuration in your WAAS network, see the [Cisco Wide Area Application Services Quick Configuration Guide](#).

- Step 4** From the Interception Method drop-down list, choose **wccp** to enable the WCCP interception method. If you change this setting from any setting other than None, click **Submit** to update the window with the proper fields for configuring WCCP.
- Step 5** Check the **Enable WCCP Service** check box to enable WCCP Version 2 on the chosen device, or uncheck the check box to disable WCCP on the chosen device.



Note Ensure that the routers used in the WCCP environment are running a version of the Cisco IOS software that also supports WCCP Version 2.



Note If you use the Central Manager to disable WCCP on a WAAS device, the Central Manager immediately shuts down WCCP and closes existing connections, if any, ignoring the setting configured by the **wccp shutdown max-wait** global configuration command. To gracefully shut down WCCP connections, use the **no enable WCCP** configuration command on the WAAS device.

- Step 6** (Optional) You can enable single service mode by checking the **Enable Single Service Mode** check box (the default). Single service mode simplifies configuration by using the same service ID for incoming and outgoing traffic, which is possible only with an AppNav deployment because it can handle asymmetric traffic flows.

- Step 7** In the Service ID1 field, specify the service ID of the WCCP service.

If the Enable Single Service Mode check box is unchecked, a pair of WCCP service IDs are required, and the Service ID2 field is filled in with the second service ID of the pair, which is one greater than Service ID1. The default service IDs are 61 and 62. You can change the WCCP service IDs from the default of 61/62 to a different pair of numbers, which allows a router to support multiple WCCP farms because the ANCs in different farms can use different service IDs.

The router service priority varies inversely with the service ID. The service priority of the default service IDs 61/62 is 34. If you specify a lower service ID, the service priority is higher than 34; if you specify a higher service ID, the service priority is lower than 34.

- Step 8** Check the **Use Default Gateway as WCCP Router** check box to use the default gateway of the WAE device as the router to associate with the WCCP TCP promiscuous mode service. Alternatively, you can uncheck this check box and specify a list of one more routers by their IP addresses, separated by spaces. The Central Manager assigns the router list number, which is displayed next to the router list field after the page is submitted. As part of the initial configuration of your WAAS network, you may have already created a WCCP router list with the setup utility, as described in the [Cisco Wide Area Application](#)

Services Quick Configuration Guide. For more information about WCCP router lists, see [Configuring and Viewing WCCP Router Lists for WAEs](#).



Note Checking or unchecking the **Use Default Gateway as WCCP Router** check box, changing the router list, or submitting the WCCP page removes existing router lists, if any, that are not assigned to the WCCP service, including router lists configured by the setup utility or through the CLI.

Step 9 (Optional) To use a custom service mask, enter different mask values in the WCCP Assignment Settings for Load Balancing area, overwriting the default mask settings. If you do not change these settings, the defaults are used. Define the custom mask as follows:

- In the Source IP Mask field, specify the IP address mask defined by a hexadecimal number, for example, FE000000, used to match the packet source IP address. The range is 00000000 to FE000000. The default is F.
- In the Destination IP Mask field, specify the IP address mask defined by a hexadecimal number, for example, FE000000, used to match the packet destination IP address. The range is 00000000 to FE000000. The default is 0.

For more information, see [Information About Load Balancing and WAEs](#).

If the WAE detects that its configured mask is not the same as advertised by one or more routers in the farm, it is not allowed to join the farm and a major alarm is raised (**Configured mask mismatch for wccp**). This alarm can occur when a WAE is trying to join a farm that already has other WAEs, and these other WAEs are configured with a different mask. The routers do not allow other WAEs to join the farm unless they advertise the same mask. To correct this alarm, ensure that all the WAEs in the farm are configured with the same mask. This alarm is cleared when the WAE's configured mask matches the mask of all the routers in the farm.

Step 10 (Optional) Modify the current advanced settings in the Advanced WCCP Settings area as follows:

- a. From the Redirect Method drop-down list, choose the type of packet redirection (forwarding) method to use:
 - WCCP GRE to use Layer 3 GRE packet redirection.
 - WCCP L2 (the default) to permit the WAE to receive transparently redirected traffic from a WCCP Version 2-enabled switch or router if the WAE has a Layer 2 connection with the device and the device is configured for Layer 2 redirection. For more information, see [Information About Packet-Forwarding Methods](#).

The return method is set the same as the redirect method. The return method is generic GRE when the WCCP GRE redirect method is chosen or WCCP L2 return when the WCCP L2 redirect method is chosen.

- b. In the Failure Detection Timeout drop-down list, choose the failure detection timeout value (3, 6, 9, 15, or 30 seconds). The default is 30 seconds and is the only value supported on WAAS versions prior to 4.4.1. This failure detection value determines how long it takes the router to detect a WAE failure.

The failure detection timeout value is negotiated with the router and takes effect only if the router also has the variable timeout capability. If the router has a fixed timeout of 30 seconds and you have configured a failure detection value on the WAE other than the default 30 seconds, the WAE is not able to join the farm and an alarm is raised (**Router unusable with a reason of Timer interval mismatch with router**).

- c. In the Weight field, specify the weight value that is used for load balancing. The weight value ranges from 0 to 10000. If the total of all the weight values of the WAEs in a service group is less than or equal to 100, then the weight value represents a literal percentage of the total load redirected to the device for load-balancing purposes. For example, a WAE with a weight of 10 receives 10 percent of the total load in a service group where the total of all weight values is 50. If a WAE in such a service group fails, the other WAEs still receive the same load percentages as before the failure; they will not receive the load allocated to the failed WAE.

If the total of all the weight values of the WAEs in a service group is between 101 and 10000, then the weight value is treated as a fraction of the total weight of all the active WAEs in the service group. For example, a WAE with a weight of 200 receives 25 percent of the total load in a service group where the total of all the weight values is 800. If a WAE in such a service group fails, the other WAEs will receive the load previously allocated to the failed WAE. The failover handling is different than if the total weights are less than or equal to 100.

By default, weights are not assigned and the traffic load is distributed evenly between the WAEs in a service group.

- d. In the Password field, specify the password to be used for secure traffic between the WAEs within a cluster and the router for a specified service. Be sure to enable all the other WAEs and routers within the cluster with the same password. Passwords must not exceed eight characters in length. Do not use the following characters: space, backwards single quote (`), double quote ("), pipe (|), or question mark (?). Re-enter the password in the Confirm Password field.



Note For information about how to use the CLI to specify the service group password on a router, see [Setting a Service Group Password on a Router](#).

Step 11 Click **Submit** to save the settings.

To configure WCCP settings from the CLI, you must first set the interception method to WCCP by using the **interception-method** global configuration command, and then you can use the **wccp router-list** and **wccp tcp-promiscuous** global configuration commands.

Configuring and Viewing WCCP Router Lists for WAEs

You can configure and view one router list from the Central Manager through the WCCP settings (see [Configuring or Viewing the WCCP Settings on WAEs](#)). The Central Manager supports only a single router list assigned to the WCCP service and removes existing router lists, if any, that can be configured through the CLI if you use the Central Manager to configure a router list, check or uncheck the **Use Default Gateway** check box in the WCCP settings page, or submit the WCCP settings page. To configure a router list through the CLI, use the **wccp router-list** global configuration command.



Note WCCP must be enabled before you can use the WCCP global configuration commands.

To delete a router list, use the **no wccp router-list** global configuration command.

To view an unassigned router list configured by the **wccp router-list** command, use the **show running-config wccp EXEC** command.

Configuring WAEs for a Graceful Shutdown of WCCP

To prevent broken TCP connections, the WAE performs a clean shutdown of WCCP after you disable WCCP Version 2 on a WAE, or reload the WAE from the CLI. You can perform this task locally through the CLI on a device by entering the **no enable** WCCP configuration command.

The WAAS Central Manager also allows you to disable WCCP Version 2 on a WAE, but this does not perform a graceful shutdown of WCCP connections. To disable WCCP immediately for a chosen device, uncheck the **Enable WCCP** check box in the WAAS Central Manager Interception Configuration window. (See [Figure 5-3](#).)



Note

If you use the Central Manager to disable WCCP on a WAAS device, the Central Manager immediately shuts down WCCP and closes existing connections, if any, ignoring the setting configured by the **wccp shutdown max-wait** global configuration command. To gracefully shut down WCCP connections, use the **no enable** WCCP configuration command on the WAAS device.

During a graceful shutdown, the WAE does not reboot until one of the following occurs:

- All the connections have been serviced.
- The maximum wait time (specified in the Shutdown Delay field in the WCCP Configuration Settings window, or with the **wccp shutdown max-wait** command [by default, 120 seconds]) has elapsed for WCCP Version 2.

During a clean shutdown of WCCP, the WAE continues to service the flows that it is handling, but it starts to bypass new flows. When the number of flows goes down to zero, the WAE takes itself out of the group by having its buckets reassigned to other WAEs by the lead WAE. TCP connections can still be broken if the WAE crashes or is rebooted without WCCP being cleanly shut down.

You cannot shut down an individual WCCP service on a particular port on a WAE; you must shut down WCCP on the WAE. After WCCP is shut down on the WAE, the WAE preserves its WCCP configuration settings.

Configuring Static Bypass Lists for WAEs



Note

Static bypass lists are supported only for devices (but not device groups) using WAAS versions earlier than 5.0, and are deprecated for such devices. Interception ACLs are recommended instead.

Using a static bypass allows traffic flows between a configurable set of clients and servers to bypass handling by the WAE. By configuring static bypass entries on the branch WAE, you can control traffic interception without modifying the router configuration. IP access lists can be configured separately on the router to bypass traffic without first redirecting it to the branch WAE. Typically, the WCCP accept list defines the group of servers that are accelerated (and the servers that are not). Static bypass can be used occasionally when you want to prevent WAAS from accelerating a connection from a specific client to a specific server (or from a specific client to all servers).

**Note**

We recommend that you use ACLs on the WCCP-enabled router where possible, rather than using static bypass lists or interception ACLs on the WAEs, because that is the most efficient method to control traffic interception. If you decide to use static bypass lists or interception ACLs, we recommend that you use interception ACLs because they are more flexible and give better statistics about passed-through connections. For information about how to configure ACLs on a router, see [Configuring IP Access Lists on a Router](#). For information about how to configure an interception ACL for a WAE, see [Configuring Interception Access Control Lists](#).

To configure a static bypass list for a Version 4.x WAE, follow these steps:

-
- Step 1** From the WAAS Central Manager menu, choose **Devices** > *device-name*.
 - Step 2** Choose **Configure** > **Interception** > **Bypass Lists**.
 - Step 3** In the taskbar, click the **Create New WCCP/Inline Bypass List** icon. The Creating new WCCP/Inline Bypass List window appears.
 - Step 4** In the Client Address field, enter the IP address for the client.
 - Step 5** In the Server Address field, enter the IP address for the server.
 - Step 6** Check **Submit** to save the settings.
-

To configure a static bypass list from the CLI, you can use the **bypass static** global configuration command.

Configuring Interception Access Control Lists

You can configure an interception ACL to control what incoming traffic across all interfaces is to be intercepted by an ANC or WAE device (on an ANC, the interception ACL is called an AppNav Controller interception ACL). Packets that are permitted by the ACL are intercepted by the device, and packets that are denied by the ACL are passed through without processing.

WAAS allows or denies optimization based on how the interception ACL processes a TCP SYN packet at the start of a TCP connection, and allows or denies optimization based on the SYN packet matching or not matching a permit statement in the ACL.

- You do not need to configure a “symmetric ACL entry” to allow a connection to be optimized when the SYN packet is matching.
- You do need to configure the “symmetric ACL entry” if you want to allow optimization for a connection established in the opposite direction (“from server to client”).

The following is an example of how the **ip access-list** global configuration command marks connections for optimization:

```
WAE(config)# ip access-list extended optimized_traffic permit ip host 1.1.1.1 host 2.2.2.2
WAE(config)# interception access-list optimized_traffic
```

- In this example, if a SYN packet with source ip 1.1.1.1 and destination ip 2.2.2.2 hits the WAAS device, the WAAS device would mark the connection for optimization.
- In this example, if a SYN packet with source ip 2.2.2.2 and destination ip 1.1.1.1 hits the WAAS device, the connection will be put in "PT Interception ACL." If you want both types of connections to be optimized, add "permit ip host 2.2.2.2 host 1.1.1.1" to the access list.

**Note**

If Interception ACLs are applied to peer WAAS devices, the ACL entries must be specular on the two devices to allow a connection to be marked for optimization on both sides.

By configuring an interception ACL on a WAAS device, you can control traffic interception without modifying the router configuration. IP ACLs can be configured separately on the router to bypass traffic without first redirecting it to the WAAS device. Typically, the WCCP accept list defines the group of servers that are accelerated (and the servers that are not). Using an interception ACL allows you to easily bypass uninteresting traffic, for example, in a pilot deployment where you do not want to modify the router configuration. Additionally, it allows you to more easily transition from a pilot to a production deployment by allowing and accelerating different kinds of traffic in phases.

An interception ACL can be used both with WCCP and inline interception.

When used with interface ACLs and WCCP ACLs, the interface ACL is applied first, the WCCP ACL is applied second, and then the interception ACL is applied last. Application policies defined on the WAE are applied after all ACLs have filtered the traffic.

An ANC that is also operating as a WAAS node can have both an AppNav Controller interception ACL to control what is intercepted by the ANC and an interception ACL to control what is accepted by the optimizing engine. A flow may be permitted by the AppNav Controller interception ACL, but subsequently rejected by the WAAS node interception ACL.

**Note**

The interception ACL feature is mutually exclusive with static bypass lists. You cannot use both types of lists at the same time. We recommend that you use interception ACLs instead of static bypass lists. Static bypass lists are supported only for devices using WAAS versions earlier than 5.0.

To use an interception ACL, first define an ACL (see [Chapter 9, “Creating and Managing IP Access Control Lists for Cisco WAAS Devices”](#)) and then apply it to a device. Interception ACLs are configured only for individual devices and not for device groups.

To configure an interception ACL for an ANC or WAE device, follow these steps:

-
- Step 1** Follow the instructions in [Chapter 9, “Creating and Managing IP Access Control Lists for Cisco WAAS Devices”](#) to create an ACL that you want to use for interception, but do not apply it to an interface.
 - Step 2** From the WAAS Central Manager menu, choose **Devices > device-name**.
 - Step 3** Choose **Configure > Interception > Interception Access List**.
 - Step 4** To configure a WAE interception ACL, click the arrow next to the Interception Access List field to display a drop-down list of ACLs you have defined, and choose an ACL to apply to WAE interception. Alternatively, you can enter an ACL name directly in the field and create it after you submit this page. If you enter information, drop-down list of displayed ACLs is filtered to show only the entries that match the beginning of the entered text.

To create or edit an ACL, click the **Go to IP ACL** link next to the field to take you to the IP ACL configuration window (**Configure > Network > TCP/IP Settings > IP ACL**).
 - Step 5** To configure an ANC interception ACL, click the arrow next to the AppNav Controller Interception Access List field to display a drop-down list of ACLs you have defined and choose an ACL to apply to ANC interception. Alternatively, you can enter an ACL name directly in the field and create it after you submit this page. If you enter information, drop-down list of displayed ACLs is filtered to show only entries that match the beginning of the entered text. This field is displayed only on devices configured in appnav-controller mode.

To create or edit an ACL, click the **Go to IP ACL** link to take you to the IP ACL configuration window (**Configure > Network > TCP/IP Settings > IP ACL**).

Step 6 Check **Submit** to save the settings.



Note

In AppNav Controller interception ACLs, the **tcp ... established** extended ACL condition is not supported and is ignored if encountered.

To configure an interception ACL from the CLI, use the **ip access-list** and **interception access-list** global configuration commands. To configure an AppNav Controller interception ACL, use the **interception appnav-controller access-list** global configuration command.

You can determine if a connection was passed through by an interception ACL by using the **show statistics connection EXEC** command. Flows passed through by an interception ACL are identified with the connection type PT Interception ACL.

Additionally, the **show statistics pass-through** command “Interception ACL” counter reports the number of active and completed pass-through flows due to an interception ACL.

Use the **show ip access-list** command to view the individual ACL rules that are being matched.

Configuring Egress Methods for WCCP-Intercepted Connections

This section contains the following topics:

- [Information About Egress Methods](#)
- [Configuring the Egress Method](#)
- [Configuring a GRE Tunnel Interface on a Router](#)

Information About Egress Methods

Cisco WAAS software supports the following egress methods for WCCP-intercepted connections:

- IP forwarding
- WCCP GRE return (available only if the redirect method is WCCP GRE; called WCCP-negotiated return for devices earlier than Version 5.0)
- Generic GRE (available only if the redirect method is WCCP GRE)
- Layer 2 (available only if the redirect method is WCCP L2)



Note

For ANCs, the egress method is not configurable. The egress method that is used depends on the redirect method. The ANC uses generic GRE when the WCCP GRE redirect method is chosen, or Layer 2 when the WCCP L2 redirect method is chosen.

The default egress method is L2. This egress method sends out optimized data through a Layer 2 connection to the router. This method is available only if the redirect method is also set to WCCP L2, and is not available on devices using WAAS versions earlier than 5.0. The router must also support Layer 2 redirect. If you configure the WCCP GRE redirect method or switch between WCCP GRE and L2, the default egress method is set to IP Forwarding.

For devices with a WAAS version earlier than 5.0, the default egress method is IP forwarding. The IP forwarding egress method does not allow you to place WAEs on the same VLAN or subnet as the clients and servers, and it does not ensure that packets are returned to the intercepting router.

The WCCP GRE return and generic GRE egress methods allow you to place WAEs on the same VLAN or subnet as clients and servers. Repeating redirection is prevented by encapsulating the outgoing frames in the GRE frames. Routers using Cisco IOS software handle these GRE frames as bypass frames, and do not apply WCCP redirection. With the WCCP GRE return method, WAAS uses the router ID address as the destination for GRE frames; with the generic GRE method, WAAS uses the address of the router configured in the WAE router list.

This technique makes it possible to support redundant routers and router load balancing; WAAS makes a best effort to return frames back to the router from which they arrived, though this is not guaranteed.

To use this functionality with multiple routers connected to the WAAS network segment, ensure connectivity to the router ID address, for example, by configuring static routes. The router ID is the address of the first loopback interface or highest active physical interface. This address can be found in the output of the **show wccp routers EXEC** command.

WAAS applies the following logic in its router selection for WCCP GRE and generic GRE:

- When the WAAS software applies data redundancy elimination (DRE) and compression to a TCP flow, the number of packets that are sent out may be fewer. A single packet that carries optimized data may represent original data that was received in multiple packets redirected from different routers. That optimized data-carrying packet will egress from the WAE to the router that last redirected a packet to the WAE for that flow direction.
- When the WAE receives optimized data, the data may arrive in multiple packets from different routers. The WAAS software expands the optimized data back to the original data, which will be sent out as several packets. Those original data-carrying packets will egress from the WAE to the router that last redirected a packet to the WAE for that flow direction.

The WCCP GRE return and generic GRE egress methods are similar, but the generic GRE egress method is designed specifically to be used in deployments where the router or switch performs hardware-accelerated processing of GRE packets, such as with a Cisco 7600 Series router or a Catalyst 6500 Series switch with the Supervisor Engine 32 or 720. Additionally, the generic GRE egress method returns packets to the intercepting router by using a GRE tunnel that you must configure on the router (the WAE end of the tunnel is configured automatically). The generic GRE egress method is supported only when the WCCP GRE interception method is used.

To use the generic GRE egress method, you must create an intercepting router list on the WAE (multicast addresses are not supported) and configure a GRE tunnel interface on each router. For details on configuring GRE tunnel interfaces on the routers, see [Configuring a GRE Tunnel Interface on a Router](#).



Note

For devices with WAAS versions earlier than 5.0, WCCP Version 2 is capable of negotiating the redirect method and the return method for intercepted connections. The WAAS software supports WCCP GRE and WCCP Layer 2 as WCCP-negotiated return methods. If WCCP negotiates a WCCP Layer 2 return, the WAE defaults to using IP forwarding as the egress method. The WAE also defaults to IP forwarding if the interception method is set to WCCP Layer 2 and you configure generic GRE as the egress method, both of which are not compatible. When the WAE defaults to IP forwarding, the WAE logs a minor alarm that is cleared when you correct the configuration so that the interception and egress methods are consistent. The output of the **show egress methods EXEC** command also displays a warning if the interception and egress methods are not consistent.

For devices with WAAS Version 5.0, you must explicitly configure the egress method.

Configuring the Egress Method

To configure the egress method for WCCP-intercepted connections from the Central Manager, see [Configuring or Viewing the WCCP Settings on WAEs](#).

To configure the egress method for WCCP GRE packet return from the CLI, use the **egress-method WCCP** configuration command:

```
WAE(config)# wccp tcp-promiscuous service-pair 61 62
WAE(config-wccp-service)# egress-method wccp-gre
```

To configure the egress method for L2 return from the CLI, use the **egress-method WCCP** configuration command:

```
WAE(config)# wccp tcp-promiscuous service-pair 61 62
WAE(config-wccp-service)# egress-method L2
```

To configure the generic GRE egress method from the CLI, configure an intercepting router list and configure the egress method, as follows:

```
WAE(config)# wccp router-list 1 192.168.68.98
WAE(config)# wccp tcp-promiscuous service-pair 61 62
WAE(config-wccp-service)# router-list-num 1
WAE(config-wccp-service)# egress-method generic-gre
```

The router list must contain the IP address of each intercepting router. Multicast addresses are not supported. Additionally, you must configure a GRE tunnel interface on each router. For details on configuring GRE tunnel interfaces on the routers, see [Configuring a GRE Tunnel Interface on a Router](#).

To view the egress method that is configured and that is being used on a particular WAE, use the **show wccp egress EXEC** command. To view information about the egress method for each connection segment, use the **show statistics connection egress-methods EXEC** command.

To view the generic GRE tunnel statistics for each intercepting router, use the **show statistics generic-gre EXEC** command. To clear statistics information for the generic GRE egress method, use the **clear statistics generic-gre EXEC** command.

Configuring a GRE Tunnel Interface on a Router

If you plan to use the generic GRE egress method on the WAE, configure a GRE tunnel interface on each intercepting router. For ease of configuration, we recommend that you create a single multipoint tunnel on the router, instead of one point-to-point tunnel per WAE in the farm.

If you have only one WAE in the farm, you can use a point-to-point tunnel. However, ensure that the router is configured with no other tunnel that has the same tunnel source as the WAE tunnel.



Note

On a Catalyst 6500 Series switch with the Supervisor Engine 32 or 720, do not configure more than one GRE tunnel (multipoint or point-to-point) with the same tunnel source interface, because this may result in high switch CPU load.

The tunnel interface must have a Layer 3 source interface to which it is attached, and this source interface must be the interface whose IP address is configured in the WAE's intercepting router list.

The tunnel interface must be excluded from WCCP interception to avoid routing loops when outbound interception is used. Use the **ip wccp redirect exclude in** command. You can always use this command because it does not cause any impact even when it is not required, such as for inbound interception.

**Note**

To configure WCCP to work with WAEs with the generic GRE egress method, you must configure keepalives on the tunnel interface used on the Cisco WCCP router. The following is a sample configuration:

```
interface Tunnel1
ip address 12.12.12.12 255.255.255.0
no ip redirects
ip wccp redirects exclude in
keepalive 20 3 <<<<<<<<<<<<<<<<<<<
tunnel source FastEthernet0/.130
tunnle mode gre multipoint
```

For more information, see the [WCCP Router Configuration Commands](#) section of the *Cisco IOS Configuration Fundamentals Command Reference*.

This section contains the following topics:

- [Multipoint Tunnel Configuration](#)
- [Point-To-Point Tunnel Configuration](#)

Multipoint Tunnel Configuration

Consider a deployment in which there are two intercepting routers and two WAEs in the farm. Each WAE configuration will look like the following example:

```
wccp router-list 1 192.168.1.1 192.168.2.1
wccp tcp-promiscuous service-pair 61 62
  router-list-num-1
  egress-method generic-gre
  redirect-method gre
  enable
```

Each router can configure a single multipoint GRE tunnel to the WAE farm.

Router 1 configuration will look like the following example:

```
interface gigabitEthernet 1/1
ip address 192.168.1.1 255.255.255.0
...
interface Tunnel1
ip address 12.12.12.1 255.255.255.0
tunnel source GigabitEthernet1/1
tunnel mode gre multipoint
ip wccp redirect exclude in
end
```

Router 2 configuration will look like the following:

```
interface Vlan815 1/0
ip address 192.168.2.1 255.255.255.0
...
interface Tunnel1
ip address 13.13.13.1 255.255.255.0
tunnel source vlan815
tunnel mode gre multipoint
ip wccp redirect exclude in
end
```

**Note**

The tunnel interface is enabled for IP by provisioning an IP address, which allows it to process and forward transit packets. If you do not want to provision an IP address, the tunnel must be IP enabled by making it an IP unnumbered interface. This restricts the tunnel; it can only be a point-to-point tunnel.

Point-To-Point Tunnel Configuration

This section describes how to configure a point-to-point tunnel for a single WAE instead of a multipoint tunnel on the router. A point-to-point tunnel is enabled for IP either by making it unnumbered or by giving it an IP address. The unnumbered method is shown in the following example router configuration:

```
interface gigabitEthernet 1/1
ip address 192.168.1.1 255.255.255.0
...
! Tunnel1 is an unnumbered point-to-point tunnel towards WAE1
interface Tunnel1
ip unnumbered GigabitEthernet1/1
tunnel source GigabitEthernet1/1
! tunnel destination is the IP address of WAE1
tunnel destination 10.10.10.10
ip wccp redirect exclude in
end
```

Using Policy-Based Routing Interception

This section contains the following topics:

- [Information About Policy-Based Routing](#)
- [Configuring Policy-Based Routing](#)
- [Methods of Verifying PBR Next-Hop Availability](#)

Information About Policy-Based Routing

Policy-based routing (PBR), introduced in Cisco IOS Release 11.0, allows you to implement policies that selectively cause packets to take specific paths in the network.

PBR also provides a method to mark packets so that certain kinds of traffic receive differentiated, preferential service when used in combination with queuing techniques enabled through the Cisco IOS software. These queuing techniques provide an extremely powerful, simple, and flexible tool to network managers who implement routing policies in their networks.

PBR enables a router to put packets through a route map before routing them. When configuring PBR, you must create a route map that specifies the match criteria, and the resulting action, if all the match clauses are met. You must enable PBR for that route map on a particular interface. All the packets arriving on the specified interface matching the match clauses will be subject to PBR.

One interface can have only one route map tag; but you can have several route map entries, each with its own sequence number. Entries are evaluated in the order of their sequence numbers until the first match occurs. If no match occurs, packets are routed as usual.

```
Router(config-if)# ip policy route--tag
```

The route map determines which packets are routed next.

You can enable PBR to establish a route that goes through WAAS for some or all packets. WAAS proxy applications receive PBR-redirected traffic in the same manner as WCCP redirected traffic:

1. In the branch office, define traffic of interest on the branch office router (Edge-Router1) as follows:
 - a. Specify which traffic is of interest to the LAN interface (ingress interface) on Edge-Router1.
Use extended IP access lists to define traffic of interest (traffic from all or filtered local source addresses to any or filtered destination address).
 - b. Specify which traffic is of interest to the WAN interface (egress interface) on Edge-Router1.
Use extended IP access lists to define traffic of interest (traffic from all or filtered local source addresses from any or filtered remote addresses).
2. In the data center, specify which traffic is of interest to the data center router (Core-Router1) as follows:
 - a. Specify which traffic is of interest to the LAN interface (ingress interface) on Core-Router1.
Use extended IP access lists to define traffic of interest (traffic from all or filtered local source addresses to any or filtered destination address).
 - b. Specify which traffic is of interest to the WAN interface (egress interface) on Core-Router1.
Use extended IP access lists to define traffic of interest (traffic from all or filtered local source addresses from any or filtered remote addresses).
3. In the branch office, create route maps on Edge-Router1, as follows:
 - a. Create a PBR route map on the LAN interface of Edge-Router1.
 - b. Create a PBR route map on the WAN interface of Edge-Router1.
4. In the data center, create route maps on Core-Router1, as follows:
 - a. Create a PBR route map on the LAN interface of Core-Router1.
 - b. Create a PBR route map on the WAN interface of Core-Router1.
5. In the branch office, apply the PBR route maps to Edge-Router1.
6. In the data center, apply the PBR route maps to Core-Router1.
7. Determine which PBR method to use to verify PBR next-hop availability of a WAE. For more information, see [Methods of Verifying PBR Next-Hop Availability](#).

Note

For a description of the PBR commands that are referenced in this section, see *Cisco Quality of Service Solutions Command Reference*.

WAEs (Edge-WAE1 and Core-WAE1) must reside in an out-of-band network that is separate from the traffic's destination and source. For example, Edge-WAE1 is on a subnet that is separate from the clients (the traffic source), and Core-WAE that is on a subnet separate from the file servers and application servers (the traffic destination). Additionally, the WAE may have to be connected to the router that is redirecting traffic to it through a tertiary interface (a separate physical interface) or a subinterface to avoid a routing loop. For more information, see [Using Tertiary Interfaces or Subinterfaces to Connect WAEs to Routers](#) in Chapter 2, "Planning Your WAAS Network."

[Table 5-3](#) provides a summary of the router interfaces that you must configure to use PBR or WCCP Version 2 to transparently redirect traffic to a WAE.

Table 5-3 Router Interfaces for WCCP or PBR Traffic Redirection to WAEs

Router interface	Comment
Edge-Router1	
A	Edge LAN interface (ingress interface) that performs redirection on outbound traffic.
B	Tertiary interface (separate physical interface) or a subinterface off of the LAN port on Edge-Router1. Used to attach Edge-WAE1 to Edge-Router1 in the branch office.
C	Edge WAN interface (egress interface) on Edge-Router1 that performs redirection on inbound traffic.
Core-Router1	
D	Core LAN interface (ingress interface) that performs redirection on outbound traffic.
E	Tertiary interface or subinterface off of the LAN port on Core-Router1. Used to attach Core-WAE1 to Core-Router1 in the data center.
F	Core WAN interface (egress interface) on Core-Router1 that performs redirection on inbound traffic.

The example provided in [Configuring Policy-Based Routing](#) shows how to configure PBR as the traffic redirection method in a WAAS network that has one WAE in a branch office and one WAE in the data center.

**Note**

The commands that are used to configure PBR on a router, can vary based on the Cisco IOS release installed on the router. For information about the commands that are used to configure PBR for the Cisco IOS release that you are running on your routers, see the appropriate Cisco IOS configuration guide.

Configuring Policy-Based Routing

The example provided in this section shows how to configure PBR as the traffic redirection method in a WAAS network that has one WAE in a branch office and one WAE in the data center.

To configure PBR to transparently redirect TCP traffic to WAEs, follow these steps:

- Step 1** In the branch office, use extended IP access lists to specify which traffic is of interest to the LAN interface (ingress interface-A) on Edge-Router:
- a. On Edge-Router1, define an extended IP access list within the range of 100 to 199. For example, create access list 100 on Edge-Router1:

```
Edge-Router1(config)# ip access-list extended 100
```
 - b. On Edge-Router1, specify which traffic is of interest to this particular interface. For example, mark any IP/TCP traffic from any local source addresses (traffic for any branch office clients) on any TCP port to any destination, as interesting:

```
Edge-Router1(config-ext-nacl)# permit tcp 10.10.10.0 0.0.0.255 any
```

 - Alternatively, you can selectively mark interesting traffic by defining the source IP subnet, destination IP address, and TCP port numbers. For example, mark IP/TCP traffic from any local source address on TCP ports 135 and 80 to any destination as interesting:

```
Edge-Router1(config-ext-nacl)# permit tcp 10.10.10.0 0.0.0.255 any eq 135
```

```
Edge-Router1(config-ext-nacl)# permit tcp 10.10.10.0 0.0.0.255 any eq 80
```

Step 2 In the branch office, use extended IP access lists to specify which traffic is of interest to the WAN interface (egress interface-C) on Edge-Router1:

- a. On Edge-Router1, define an extended IP access list within the range of 100 to 199, for example, create access list 101 on Edge-Router1:

```
Edge-Router1(config)# ip access-list extended 101
```

- b. On Edge-Router1, specify which traffic is of interest to its WAN interface:

- For example, mark any IP/TCP traffic to a local device, as interesting:

```
Edge-Router1(config-ext-nacl)# permit tcp any 10.10.10.0 0.0.0.255
```

- Alternatively, you can selectively mark interesting traffic by defining the source IP subnet, destination IP address, and TCP port numbers. For example, mark IP/TCP traffic to any local source addresses on TCP ports 135 and 80 to any destination, as interesting:

```
Edge-Router1(config-ext-nacl)# permit tcp any 10.10.10.0 0.0.0.255 eq 135
```

```
Edge-Router1(config-ext-nacl)# permit tcp any 10.10.10.0 0.0.0.255 eq 80
```

Step 3 In the data center, use extended IP access lists to specify which traffic is of interest to the LAN interface (ingress interface-D) on Core-Router1:

- a. On Core-Router1, define an extended IP access list within the range of 100 to 199, for example, create access list 102 on Core-Router1:

```
Core-Router1(config)# ip access-list extended 102
```

- b. On Core-Router1, specify which traffic is of interest to its LAN interface:

- For example, mark any IP/TCP traffic sourced from any local device, for example, traffic sourced from any file server or application server in the data center, on any TCP port to any destination, as interesting:

```
Core-Router1(config-ext-nacl)# permit tcp 10.10.11.0 0.0.0.255 any
```

- Alternatively, you can selectively mark traffic as interesting by defining the source IP subnet, destination IP address, and TCP port numbers. For example, selectively mark IP/TCP traffic sourced from any local device on TCP ports 135 and 80 to any destination, as interesting:

```
Core-Router1(config-ext-nacl)# permit tcp 10.10.11.0 0.0.0.255 any eq 135
```

```
Core-Router1(config-ext-nacl)# permit tcp 10.10.11.0 0.0.0.255 any eq 80
```

Step 4 In the data center, use extended IP access lists to mark traffic of interest for the WAN interface (egress interface-F) on Core-Router1:

- a. On Core-Router1, define an extended access list within the range of 100 to 199, for example, create access list 103 on Core-Router1:

```
Core-Router1(config)# ip access-list extended 103
```

- b. On Core-Router1, mark interesting traffic for the WAN interface:

- For example, mark any IP/TCP traffic destined to any local device (for example, traffic destined to any file server or application server in the data center) as interesting:

```
Core-Router1(config-ext-nacl)# permit tcp any 10.10.11.0 0.0.0.255
```

- Alternatively, you can selectively mark traffic as interesting by defining the source IP subnet, destination IP address, and TCP port numbers. For example, mark IP/TCP traffic on ports 135 and 80 to any local source addresses, as interesting:

```
Core-Router1(config-ext-nacl)# permit tcp any 10.10.11.0 0.0.0.255 eq 135
Core-Router1(config-ext-nacl)# permit tcp any 10.10.11.0 0.0.0.255 eq 80
```

Step 5 In the branch office, define PBR route maps on Edge-Router1:

- a. Define a route map for the LAN interface (ingress interface). The following example shows how to create a WAAS-EDGE-LAN route map:

```
Edge-Router1(config)# route-map WAAS-EDGE-LAN permit
```

- b. Define a route map for the WAN interface (egress interface).

The following example shows how to create a WAAS-EDGE-WAN route map:

```
Edge-Router1(config)# route-map WAAS-EDGE-WAN permit
```

- c. Specify the match criteria.

Use the **match** command to specify the extended IP access list that Edge-Router1 should use to determine which traffic is of interest to its WAN interface. If you do not specify a **match** command, the route map applies to all packets.

The following example shows how to configure Edge-Router1 to use the access list 101 as the criteria for determining which traffic is of interest to its WAN interface:

```
Edge-Router1(config-route-map)# match ip address 101
```



Note The **ip address** command option matches the source or destination IP address that is permitted by one or more standard or extended access lists.

- d. Specify how the matched traffic should be handled.

The following example shows how to configure Edge-Router1 to send the packets that match the specified criteria to the next hop, which is Edge-WAE1 that has an IP address of 1.1.1.100:

```
Edge-Router1(config-route-map)# set ip next-hop 1.1.1.100
```



Note If you have more than one branch WAE, you can specify the IP address of a second branch WAE for failover purposes, for example, enter the **set ip next-hop 1.1.1.101** command on Edge-Router1, to specify a next-hop address of 1.1.1.101 (the IP address of Edge-WAE2) for failover purposes. Use the **next-hop** command for failover purposes and not for load-balancing purposes.

Step 6 In the data center, create route maps on Core-Router1:

- a. Define a route map on the LAN interface (ingress interface).

The following example shows how to create a WAAS-CORE-LAN route map:

```
Core-Router1(config)# route-map WAAS-CORE-LAN permit
```

- b. Define a route map on the WAN interface (egress interface).

The following example shows how to create a WAAS-CORE-WAN route map:

```
Core-Router1(config)# route-map WAAS-CORE-WAN permit
```

- c. Specify the match criteria.

Use the **match** command to specify the extended IP access list that Core-Router 1 should use to determine which traffic is of interest to its WAN interface. If you do not enter a **match** command, the route map applies to all the packets. The following example shows how to configure Core-Router1 to use access list 103 as the criteria for determining which traffic is of interest to its WAN interface:

```
Core-Router1(config-route-map)# match ip address 103
```

- d. Specify how the matched traffic is to be handled.

The following example shows how to configure Core-Router1 to send packets that match the specified criteria to the next hop, which is Core-WAE1 that has an IP address of 2.2.2.100:

```
Core-Router1(config-route-map)# set ip next-hop 2.2.2.100
```



Note If you have more than one data center WAE, specify the IP address of a second data center WAE for failover purposes, for example, enter the **set ip next-hop 2.2.2.101** command on Core-Router1, to specify a next-hop address of 2.2.2.101 (the IP address of Core-WAE2) for failover purposes. Use the **next-hop** command for failover purposes and not for load-balancing purposes.

Step 7 In the branch office, apply the route maps to the LAN interface (ingress interface) and the WAN interface (egress interface) on Edge-Router1:

- a. On Edge-Router1, enter interface configuration mode:

```
Edge-Router1(config)# interface FastEthernet0/0.10
```

- b. Specify that the LAN router interface should use the WAAS-EDGE-LAN route map for PBR:

```
Edge-Router1(config-if)# ip policy route-map WAAS-EDGE-LAN
```

- c. Enter interface configuration mode:

```
Edge-Router1(config-if)# interface Serial0
```

- d. Specify that the WAN router interface should use the WAAS-EDGE-WAN route map for PBR:

```
Edge-Router1(config-if)# ip policy route-map WAAS-EDGE-WAN
```

Step 8 In the data center, apply the route maps to the LAN interface (ingress interface) and the WAN interface (egress interface) on Core-Router1:

- a. On Core-Router1, enter interface configuration mode:

```
Core-Router1(config)# interface FastEthernet0/0.10
```

- b. Specify that for PBR, the LAN router interface should use the WAAS-CORE-LAN route map:

```
Core-Router1(config-if)# ip policy route-map WAAS-CORE-LAN
```

- c. Enter interface configuration mode:

```
Core-Router1(config-if)# interface Serial0
```

- d. Specify that for PBR, the WAN router interface should use the WAAS-CORE-WAN route map:

```
Core-Router1(config-if)# ip policy route-map WAAS-CORE-WAN
```

Methods of Verifying PBR Next-Hop Availability

When using PBR to transparently redirect traffic to WAEs, we recommend that you use one of the following methods to verify the PBR next-hop availability of a WAE. The method that you choose should be based on the version of the Cisco IOS software that is running on the routers and the placement of your WAEs. However, method 2 is the preferred method whenever possible:

- Method 1—If the device sees the WAEs as a CDP neighbor (directly connected), it can use CDP and ICMP to verify that the WAE is operational. For more information, see [Method 1: Using CDP to Verify Operability of WAEs](#).
- Method 2 (Recommended method)—If the device is running Cisco IOS software Release 12.4 or later and the device does not see the WAE as a CDP neighbor, use the IP service level agreements (SLAs) can be used to verify that the WAE is operational using ICMP echoes. For more information, see [Method 2: Using IP SLAs to Verify WAE Operability Using ICMP Echo Verification](#).
- Method 3—If the device is running the Cisco IOS software Release 12.4 or later and does not see the WAE as a CDP neighbor, use IP SLAs to verify that the WAE is operational using TCP connection attempts. For more information, see [Method 3: Using IP SLAs to Verify WAE Operability Using TCP Connection Attempts](#).

**Note**

In this section, *device* is used to refer to the router or switch that has been configured to use PBR to transparently redirect traffic to a WAE.

To verify whether the WAE is CDP visible to a device that has been configured to use PBR, enter the **show cdp neighbors** command on the device. If the WAE is CDP visible to the device, the WAE will be listed in the output of the **show cdp neighbors** command.

Method 1: Using CDP to Verify Operability of WAEs

If the device that is configured to use PBR views the WAEs as a CDP neighbor (the WAE is directly connected to the device), you can configure CDP and ICMP to verify the availability of a WAE as a PBR next hop.

The following example shows how to use this method to verify PBR next-hop availability of a WAE. You must complete the following configuration process for each of the LAN and WAN route maps that are configured when CDP should be used.

To use CDP to verify operability of WAEs, follow these steps:

-
- Step 1** On the router where PBR is configured, for example, on the branch office router named Edge-Router1, enter configuration mode and enable CDP on the router:
- ```
Edge-Router1 (config) # cdp run
```
- Step 2** Enable route-map configuration mode for the route map, WAAS-EGDE-LAN, which has already been created on the router:
- ```
Edge-Router1 (config) # route-map WAAS-EDGE-LAN permit
```
- Step 3** Configure the router to use CDP to verify the availability of the configured next-hop addresses:
- ```
Edge-Router1 (config-route-map) # set ip next-hop verify-availability
```
- Step 4** Enable CDP on the WAE, for example, on the branch office WAE named Edge-WAE1, that you want the router to redirect traffic to using PBR:

```
Edge-WAE1(config)# cdp enable
```

**Note**

If you are configuring PBR and have multiple WAEs, and are using Method 1 to verify the PBR next-hop availability of a WAE, no additional configuration is necessary after you have completed the preceding process.

## Method 2: Using IP SLAs to Verify WAE Operability Using ICMP Echo Verification

To use IP SLAs and ICMP (the recommended method) to verify PBR next-hop availability of a WAE, follow these steps:

- Step 1** On the branch office router named Edge-Router1, enter the route-map configuration mode for the route map named WAAS-EDGE-LAN, which has been previously configured on this router:

```
Edge-Router1(config)# route-map WAAS-EDGE-LAN permit
```

- Step 2** Specify a match condition for the traffic. In the following example, the match condition specifies access list number 105:

```
Edge-Router1(config)# match ip address 105
```

- Step 3** Configure the route map to use IP SLA tracking instance number 1 to verify the availability of the next-hop WAE, for example, the branch WAE named Edge-WAE1 that has an IP address of 1.1.1.100:

```
Edge-Router1(config-route-map)# set ip next-hop verify-availability 1.1.1.100 track 1
```

**Note**

Enter the **set ip next-hop verify-availability** command for each route map that has been configured on this branch office edge router and on the data center's core router that has also been configured to use PBR to redirect traffic to WAEs.

- Step 4** Configure IP SLA tracking instance 1:

```
Edge-Router1(config-route-map)# exit
Edge-Router1(config)# ip sla 1
Edge-Router1(config-ip-sla)#
```

- Step 5** Configure the router to echo Edge-WAE1 using the specified source interface:

```
Edge-Router1(config-ip-sla)# icmp-echo 1.1.1.100 source-interface FastEthernet 0/0.20
```

- Step 6** Configure the router to perform the echo every 20 seconds:

```
Edge-Router1(config-ip-sla)# frequency 20
Edge-Router1(config-ip-sla)# exit
```

- Step 7** Schedule IP SLA tracking instance 1 to start immediately and to run continuously:

```
Edge-Router1(config)# ip sla schedule 1 life forever start-time now
```

- Step 8** Configure IP SLA tracking instance 1 to track the device, which is defined in the IP SLA tracking instance 1:

```
Edge-Router1(config)# track 1 rtr 1
```

**Note**

If you are configuring PBR and have multiple WAEs, and you are using Method 2 to verify PBR next-hop availability of a WAE, you must configure a separate IP SLA per WAE, and then run the **track** command for each IP SLA.

### Method 3: Using IP SLAs to Verify WAE Operability Using TCP Connection Attempts

If the device that is configured for PBR is running the Cisco IOS software Release 12.4 or later, and does not see the WAE as a CDP neighbor, use IP SLAs to verify that the WAE is alive using TCP connection attempts. Use IP SLAs to monitor a WAE's availability as the PBR next hop using TCP connection attempts at a fixed interval of 60 seconds.

To verify PBR next-hop availability of a WAE, follow these steps:

- Step 1** On the branch office router named Edge-Router1, enter route-map configuration mode for the route map named WAAS-EDGE-LAN, which has been previously configured on this router:

```
Edge-Router1(config)# route-map WAAS-EDGE-LAN permit
```

- Step 2** Configure the route map to use IP SLA tracking instance number 1 to verify the availability of the next-hop WAE (the Edge WAE that has an IP address of 1.1.1.100):

```
Edge-Router1(config-route-map)# set ip next-hop verify-availability 1.1.1.100 track 1
```

**Note**

Enter the **set ip next-hop verify-availability** command for each route map that is configured on this branch office edge router and on the data center's core router that has also been configured to use PBR to transparently redirect traffic to WAEs.

- Step 3** Configure the IP SLA tracking instance 1:

```
Edge-Router1(config-route-map)# exit
Edge-Router1(config)# ip sla 1
```

- Step 4** Configure the router to use the specified source and destination ports to use TCP connection attempts at a fixed interval of 60 seconds to monitor the WAE availability:

```
Edge-Router1(config-ip-sla)# tcp-connect 1.1.1.100 80 source-port 51883 control disable
Edge-Router1(config-ip-sla)# exit
```

- Step 5** Schedule the IP SLA tracking instance 1 to start immediately and to run forever:

```
Edge-Router1(config)# ip sla schedule 1 life forever start-time now
```

- Step 6** Configure the IP SLA tracking instance 1 to track the device, that is defined in the IP SLA tracking instance 1:

```
Edge-Router1(config)# track 1 rtr 1
```

**Note**

If you are configuring PBR and have multiple WAEs, and you are using Method 3 to verify PBR next-hop availability of a WAE, you must configure a separate IP SLA per WAE, and then run the **track** command per IP SLA.

## Using Inline Mode Interception

This section contains the following topics:

- [Information About Inline Interception](#)
- [Enabling Inline Operation on WAEs](#)
- [Configuring Inline Interface Settings on WAEs](#)
- [Configuring Inline Operation on ANCs](#)
- [Configuring an IP Address on an Inline Interface](#)
- [Configuring VLANs for Inline Support](#)
- [Information About Clustering Inline WAEs](#)
- [Disabling Peer Optimization Between Serial Inline WAEs](#)

## Information About Inline Interception

A WAE can physically and transparently intercept traffic between clients and a router by using inline mode. To use inline mode, use a WAE with the Cisco WAE Inline Network Adapter or Interface Module installed. In this mode, you physically position the WAE device in the path of the traffic that you want to optimize, typically between a switch and a router, as shown in [Figure 5-5](#). Redirection of traffic is not necessary.

**Note**

When you install an inline WAE device, you must follow the cabling requirements described in the “Cabling” section of [Installing the Cisco WAE Inline Network Adapter](#) or the appropriate platform hardware guide.

Any combination of traffic interception mechanisms on peer WAEs is supported. For example, you can use inline interception on the branch WAE and WCCP on the data center WAE. For complex data center deployments, we recommend that you use hardware-accelerated WCCP interception with the WAAS AppNav solution (see [Chapter 4, “Configuring AppNav”](#)) or load balancing with the Cisco Application Control Engine (ACE).

Figure 5-5 Inline Interception

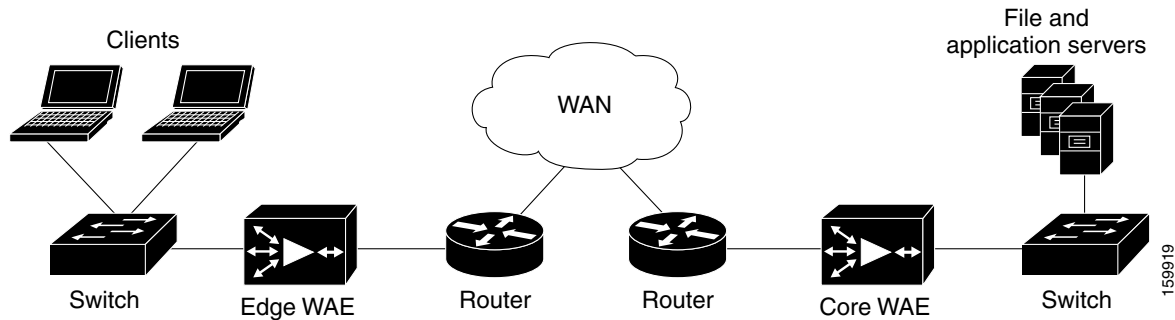
**Note**

Inline mode and WCCP redirection are exclusive. You cannot configure inline mode if the WAE is configured for WCCP operation. Inline mode is the default mode when a Cisco WAE Inline Network Adapter is installed in a WAE device, but you must configure inline mode explicitly on a device with a Cisco Interface Module.

**Note**

An inline WAE can be configured as a Central Manager, but the inline interception functionality is not be available.

The Cisco WAE Inline Network Adapter contains two or four Ethernet ports, the Cisco Interface Module contains two to eight Ethernet ports, and the Cisco AppNav Controller Interface Module contains four to 12 Ethernet ports. Ports on the Cisco WAE Inline Network Adapter are always configured as inline ports, while ports on the Interface Modules are configured as normal standalone ports by default, and you must explicitly configure these ports as inline ports. Each pair of inline ports is grouped into a logical inline group.

Each inline group has one LAN-facing port and one WAN-facing port. Typically, you use just one inline group, and connect the LAN-facing port to a switch and the WAN-facing port to a router. On adapters or interface modules with additional ports, additional groups of interfaces are provided if you are using a network topology where you have to connect a WAE to multiple routers. Traffic that enters into one interface in a group, exits the device via another interface in the same group.

Hardware platform support for inline ports is as follows:

- WAVE-294—Supports one installed Cisco Interface Module with 2, 4, or 8 ports.
- WAVE-594/694/7541/7571/8541—Support one installed Cisco Interface Module with 2, 4, or 8 ports or a Cisco AppNav Controller Interface Module with 4 or 12 ports.

**Note**

The two-port 10-Gigabit Cisco Interface Module cannot be used in inline mode. The four-port 10-Gigabit Cisco AppNav Controller Interface Module is supported only on the WAVE-594.

You have the option of assigning an IP address to an inline interface, but it is not required. For more information, see [Configuring an IP Address on an Inline Interface](#).

Traffic that flows through an inline group is transparently intercepted for optimization. Traffic that does not have to be optimized is bridged across the LAN/WAN interfaces. If a power, hardware, or unrecoverable software failure occurs, the network adapter automatically begins operating in bypass mode (fail-close), where all traffic is mechanically bridged between the LAN and WAN interfaces in

each group. The Cisco WAE Inline Network Adapter and Cisco Interface Module also operate in bypass mode when the WAE is powered off or starting up. Additionally, you can manually put an inline group into bypass mode.

**Note**

AppNav Controller Interface Modules do not support automatic bypass mode to continue traffic flow in the event of a failure. For high availability, two or more AppNav Controller Interface Modules should be deployed in an AppNav cluster. For more information on using inline mode with the AppNav solution, see [Chapter 4, “Configuring AppNav.”](#)

Inline mode is configured by default to accept all TCP traffic. If the network segment in which the WAE is inserted is carrying 802.1Q tagged (VLAN) traffic, initially, traffic on all VLANs is accepted. Inline interception can be enabled or disabled for each VLAN. However, optimization policies cannot be customized based on the VLAN.

You can serially cluster WAE devices operating in inline mode to provide higher availability if a device fails. For details, see [Information About Clustering Inline WAEs](#).

**Note**

When a WAE inline group enters bypass mode, the switch and router ports to which it is connected may have to reinitialize, which may cause an interruption of several seconds in the traffic flow through the WAE.

If the WAE is deployed in a configuration where the creation of a loop is not possible, that is, if it is deployed in a standard fashion between a switch and a router, configure PortFast on the switch port to which the WAE is connected. PortFast allows the port to skip the first few stages of the Spanning Tree Algorithm (STA) and move more quickly into a packet forwarding mode.

## Enabling Inline Operation on WAEs

This section describes how to enable and configure inline settings on WAEs configured as application accelerators and that are not part of an AppNav Cluster (WAEs that are part of an AppNav Cluster use only the appnav-controller interception method). To configure the inline settings on WAEs configured as AppNav Controllers, see [Configuring Inline Operation on ANCs](#).

On WAVE-294/594/694/7541/7571/8541 devices that use Cisco Interface Modules, the Interface Module ports are configured by default for normal standalone operation. If you want to use the device in inline mode, you must configure the ports for inline operation. Enabling inline mode configures all the ports for inline operation and converts each pair of ports to an inline group.

On other WAE devices that use the Cisco WAE Inline Network Adapter, the ports on the adapter always operate in inline mode. You can use this configuration window to enable or disable VLAN ID connection verification, which is the only setting that appears for such WAE devices.

To enable inline operation and configure general settings, follow these steps:

- 
- Step 1** From the WAAS Central Manager menu, choose **Devices > device-name**. (You cannot enable inline operation from device groups.)
  - Step 2** Choose **Configure > Interception > Interception Configuration**.





**Note** If you are configuring a device using a WAAS version earlier than 5.0, choose **Configure > Interception > Inline > General Settings** to configure inline general settings. The configuration window looks different, but has similar settings.

The Interception Configuration window appears.

**Step 3** From the Interception Method drop-down list, choose **Inline** to enable inline mode. The Interception Method drop-down list is not displayed for devices using WAAS versions earlier than 5.0.

The Interception Configuration window refreshes with the inline settings. (Figure 5-6.)

**Figure 5-6** *Inline Interception Settings Window*



**Step 4** Check the **Inline Enable** check box to enable inline operation.

The Inline Enable check box is displayed only for WAVE devices using WAAS versions earlier than 5.0 and that have a Cisco Interface Module installed.

**Step 5** Check the **VLAN ID Connection Check** check box to enable VLAN ID connection checking. Uncheck the check box to disable it. The default setting is enabled.

WAAS uses the VLAN ID to intercept or bridge VLAN traffic on the inline interface for a TCP flow. The VLAN ID of all the packets sent in a particular TCP connection must match; packets with a different VLAN ID will be bridged and not optimized. If your system has an asymmetric routing topology, in which the traffic flow in one direction uses a different VLAN ID than the traffic flow from the other direction, you may have to disable VLAN ID checking to ensure that the traffic is optimized.

**Step 6** From the Failover Timeout drop-down list, choose the failover timeout (1, 5, or 25 seconds), which is the number of seconds that the interface should wait for before going into bypass mode, after a device or power failure. The default is 1 second.

This item appears only for WAVE devices that use Cisco Interface Modules, but not for AppNav Controller Interface Modules. For devices that use Cisco WAE Inline Network Adapters, the failover timeout is configured in the Inline Interface Settings window (Figure 5-6). This item is named Time Out for WAAS versions earlier than 5.0 and appears before the VLAN ID Connection Check item.

**Step 7** Click **Submit**. A message appears, for you to confirm that all the Interface Module interfaces are to be converted to inline group interfaces, and the existing Interface Module interface configurations are to be removed.

**Step 8** Click **OK** to confirm.

The inline groups are configured with basic default settings. To configure inline group settings, see [Configuring Inline Interface Settings on WAEs](#).

For devices running WAAS versions earlier than 5.0, after enabling inline mode, it takes about two data feed poll cycles (about 10 minutes by default) for the inline groups to appear in the Inline Interfaces list in the lower part of the window.



**Note** Inline mode cannot be enabled if any of the Interface Module ports are configured as the primary interface. Change the primary interface and return to this window to enable inline mode.

For devices running WAAS versions earlier than 5.0, if you configure any of the interfaces on an Interface Module with nondefault settings (standby group, port channel, BVI, speed, duplex, IP address, ACLs, and so on), inline mode cannot be enabled, and a warning message appears, asking you to check all the interfaces for configuration settings. You must remove all the configuration settings from all the interface module interfaces (slot 1) and then return to this window to enable inline mode.

To enable inline operation from the CLI, use the **interception-method inline** global configuration command.

To configure VLAN ID checking from the CLI, use the **inline vlan-id-connection-check** global configuration command after inline operation is enabled.

## Configuring Inline Interface Settings on WAEs

This section describes how to configure inline settings on WAEs configured as application accelerators, and that are not a part of an AppNav Cluster (WAEs that are a part of an AppNav Cluster use only the appnav-controller interception method). To configure inline settings on WAEs configured as AppNav Controllers, see [Configuring Inline Operation on ANCs](#).

To configure inline interface settings, follow these steps:

**Step 1** From the WAAS Central Manager menu, choose **Devices** > *device-name*. (You cannot configure inline interface settings from device groups.)

**Step 2** Choose **Configure** > **Interception** > **Interception Configuration**.



**Note** If you are configuring a device using a WAAS version earlier than 5.0, choose **Configure** > **Interception** > **Inline** > **Inline Interfaces** to configure inline interface settings. The configuration window looks different, but has similar settings.







The Inline Interfaces window appears, listing the inline interface groups available on the device.

**Step 3** Choose an inline group to configure and click the **Edit** taskbar icon. (For devices using WAAS versions earlier than 5.0, click the **Edit** icon next to the interface.)

The Edit Inline Settings window appears, displaying the inline interface configurations for a particular slot and port group. (See [Figure 5-7](#).)

Figure 5-7 Edit Inline Settings Window

- Step 4** Check the **Use CDP** check box to enable Cisco Discovery Protocol (CDP) on the inline group interfaces. The Use CDP check box is not shown for devices using WAAS versions earlier than 5.0.
- When enabled, CDP obtains protocol addresses of neighboring devices and discovers the platform of those devices. It also shows information about the interfaces used by your router.
- Configuring CDP from the CDP Settings window enables CDP globally on all the interfaces. For information on configuring CDP settings, see [Configuring CDP Settings](#) in Chapter 6, “Configuring Network Settings.”
- Step 5** Check the **Shutdown** check box to shut down the inline group. This setting bridges traffic across the LAN/WAN interfaces without any processing.
- Step 6** In the Encapsulation field, enter the VLAN ID that is to be assigned to traffic that leaves the WAE. The VLAN ID should be set to match the VLAN ID expected by the router.
- For more information about the VLAN ID, see [Configuring an IP Address on an Inline Interface](#).
- Step 7** From the Load Interval drop-down list, choose the interval, in seconds, at which to poll the interface for statistics and calculate throughput. The default is 30 seconds. (The Load Interval item is not shown for devices using WAAS versions earlier than 5.0.)
- Step 8** Check the **Intercept all VLANs** check box to enable inline interception on the interface group. Inline interception is enabled by default when the WAE contains a Cisco WAE Inline Network Adapter, but must be explicitly enabled on devices with a Cisco Interface Module (see [Enabling Inline Operation on WAEs](#)).

- Step 9** In the Exclude VLAN field, enter a list of one or more VLAN ranges to exclude from optimization. You can enter the word **native** to exclude the native VLAN. Separate each VLAN range from the next with a comma. Alternatively, you can select VLAN ranges from a list by following these steps:
- Click **Configure Include VLANs** when you know the list of VLANs that you want to include in inline interception. This button runs a script that prompts you for a comma-separated list of VLANs that you want to include. The script generates an inverse list of all the VLANs that should be excluded and then updates the window and puts the list into the Exclude VLAN field.
  - Click **Choose VLANs from the list** to choose VLAN ranges. The VLAN Range Assignments window appears, displaying the VLAN ranges that are defined. Defining VLAN ranges is described in [Configuring VLANs for Inline Support](#).
  - Choose the VLAN ranges to include or exclude:
    - Check the check box next to each VLAN range that you want to include for optimization, and click the **Include Vlan** taskbar icon. All the VLANs that are not included for optimization are excluded. For devices using WAAS versions earlier than 5.0, click  next to each VLAN range that you want to include. The icon changes to .
    - Check the check box next to each VLAN range that you want to exclude from optimization, and click the **Exclude Vlan** taskbar icon. For devices using WAAS versions earlier than 5.0, click  next to each VLAN range that you want to exclude from optimization. The icon changes to .
    - Click the **Clear Selection** taskbar icon to clear all selections. For devices using WAAS versions earlier than 5.0, click  in the taskbar to select all the available VLAN ranges for optimization, or click  in the taskbar to exclude all the VLAN ranges from optimization.
  - Click **OK**. For devices using WAAS versions earlier than 5.0, click **Submit**.
- Step 10** From the Failover Timeout drop-down list, choose 1, 3, 5, or 10 seconds. The default is 1 second. This value sets the number of seconds after a failure event that the WAE waits for before beginning to operate in bypass mode. In bypass mode, all the traffic received on either port of the interface group is forwarded out to the other port in the group.
- This check box applies only to devices that use Cisco WAE Inline Network Adapters. For devices that use Cisco Interface Modules, the failover timeout is configured in the Inline Interception Settings window ([Figure 5-6](#)) and does not appear in this window.
- Step 11** Configure the Speed and Mode port settings as follows (these settings are not used for the interfaces on the Cisco Interface Module on a device using WAAS Version 5.0 or later, which uses auto sensing):
- Uncheck the **AutoSense** check box, which is enabled by default.
  - From the Speed drop-down list, choose a transmission speed (10, 100, 1000, or 10000 Mbps). Choose **1000 Mbps** for fiber Gigabit Ethernet interfaces on a Cisco Interface Module for devices using WAAS versions earlier than 5.0.
  - From the Mode drop-down list, choose a transmission mode (full-duplex or half-duplex). Choose **full-duplex** for fiber Gigabit Ethernet interfaces on a Cisco Interface Module for devices using WAAS versions earlier than 5.0.
-  **Note** We strongly recommend that you do not use half-duplex connections on WAEs or on routers, switches, or other devices. Half duplex impedes performance and should not be used. Check each Cisco WAE interface and port configuration on the adjacent device (router, switch, firewall, and WAE) to verify that full duplex is configured.
- Step 12** In the Address field, enter an IP address for the inline interface, if you want to assign an IP address.

- Step 13** In the Netmask field, enter a subnet mask for the inline interface.
- Step 14** Enter up to four secondary IP addresses and corresponding subnet masks in the Secondary Address and Secondary Netmask fields.
- Configuring multiple IP addresses allows the device to be present in more than one subnet and can be used to optimize response time because it allows the data to go directly from the WAAS device to the client that is requesting the information without being redirected through a router. The WAAS device becomes visible to the client because both are configured on the same subnet.
- Step 15** In the Default Gateway field, enter the default gateway IP address. The Default Gateway field is not shown for devices using WAAS versions 5.0 or later.
- Step 16** (Optional) From the Inbound ACL drop-down list, choose an IP ACL to apply to inbound packets. The drop-down list contains all the IP ACLs that you configured in the system.
- Step 17** (Optional) From the Outbound ACL drop-down list, choose an IP ACL to apply to outbound packets.
- Step 18** Under IPv6 Settings, you can manually assign an IPv6 address to the inline interface or select from the following options. If you select one of the following options, the IPv6 address field and subsequent secondary IPv6 address fields are not available.
- Use Single Link Local - A unicast address that is automatically configured on an interface using the link-local prefix FE80::/10 and the interface identifier in the modified EUI-64 format. Using this address configuration option is sufficient for nodes on a link to communicate.
  - Use Auto Config - To auto-configure an IPv6 global unicast address on the interface as per RFC 4862.
- Step 19** Enter up to four secondary IP addresses and corresponding subnet masks in the Secondary Address and Secondary Netmask fields.
- Configuring multiple IP addresses allows the device to be present in more than one subnet and can be used to optimize response time because it allows the data to go directly from the WAAS device to the client that is requesting the information without being redirected through a router. The WAAS device becomes visible to the client because both are configured on the same subnet.
- Step 20** In the Duplicate address Detection Attempts field enter a number between 0-600 to specify the number of attempts by which the duplicate address should be detected.
- Step 21** Click **OK**. (For devices using WAAS versions earlier than 5.0, click **Submit**.)
- Step 22** For WAAS Version 5.0 and later, choose **Configure > Network > Default Gateway** to configure the default gateway for an inline interface:
- a. In the Default Gateway field, enter the default gateway IP address.
  - b. Click **Submit**.

---

To configure inline interception from the CLI, use the **interface InlineGroup** global configuration command.

## Configuring Inline Operation on ANCs

This section describes how to enable and configure inline settings on WAAS devices configured as AppNav Controllers (ANCs). You can also use the AppNav Cluster wizard to configure an inline ANC and create an inline bridge interface, as described in [Creating a New AppNav Cluster with the AppNav Cluster Wizard](#) in Chapter 4, “Configuring AppNav.”

To configure the inline settings on WAEs configured as application accelerators, see [Enabling Inline Operation on WAEs](#).

On WAVE-594/694/7541/7571/8541 devices that use Cisco AppNav Controller Interface Modules, the AppNav Controller Interface Module ports are configured by default for normal standalone operation. To use the device in inline mode, you must configure the ports for inline operation and create an inline bridge group. Enabling inline mode configures all the ports for inline operation.

To enable inline operation and configure an inline bridge group, follow these steps:

**Step 1** From the WAAS Central Manager menu, choose **Devices** > *device-name*. (You cannot enable inline operation from device groups.)

**Step 2** Choose **Configure** > **Interception** > **Interception Configuration**.

The Interception Configuration window appears.

**Step 3** From the Interception Method drop-down list, choose **Inline** to enable inline mode.

**Step 4** Click **Submit** to enable inline mode and refresh the window with additional settings.

All the existing bridge groups are listed, showing the bridge group number, protocol, link state propagation setting, VLAN ranges, and included interfaces.

From this list, you can perform the following tasks:

- Edit the settings for a bridge group by choosing it, and clicking the **Edit** taskbar icon.
- Delete a bridge group by choosing it, and clicking the **Delete** taskbar icon.
- Create a new bridge group as described in the following steps.

**Step 5** Click the **Create Bridge** taskbar icon.

**Figure 5-8** Create Bridge window

**Create Bridge**

Bridge Index: 1

Protocol: interception

Description:

Link State Propagation

VLAN: all Vlan Calculator

**Assign Interfaces**

Assign  Unassign

| Assigned                    | Name                     |
|-----------------------------|--------------------------|
| <input type="checkbox"/> No | GigabitEthernet 0 / 1    |
| <input type="checkbox"/> No | TenGigabitEthernet 1 / 0 |
| <input type="checkbox"/> No | TenGigabitEthernet 1 / 1 |
| <input type="checkbox"/> No | TenGigabitEthernet 1 / 2 |

OK Cancel

**Step 6** From the Bridge Index drop-down list, choose the bridge group number.

**Step 7** (Optional) In the Description field, enter a bridge group description.

- Step 8** (Optional) Check the **Link State Propagation** check box to enable link state propagation. It is enabled by default.
- Link state propagation means that if one interface in the inline bridge group is down, the system automatically shuts down the other interface to ensure that a network failover scheme is triggered.
- Step 9** (Optional) Configure VLANs to include in interception. Initially, all the VLANs are included. To include or exclude specific VLAN ranges, follow these steps:
- Click **Vlan Calculator**.
  - For each VLAN range that you want to include in interception, choose **Add/Include** from the **Select Operation Type** drop-down list. In the Vlan Range field, enter a comma-separated list of one or more VLAN ranges to include. You can enter the word **native** to include the native VLAN.
  - For each VLAN range that you want to exclude from interception, choose **Except/Exclude** from the **Select Operation Type** drop-down list. In the Vlan Range field, enter a comma-separated list of one or more VLAN ranges to exclude. You can enter the word **native** to exclude the native VLAN.
  - Click **OK** to save your settings.
- Step 10** In the Assign Interfaces area, check the check box next to two interfaces that you want to assign to this bridge group, and then click the **Assign** taskbar icon. To unassign assigned interfaces, check each interface that you want to unassign, and click the **Unassign** taskbar icon. The bridge group can contain two physical or two port-channel interfaces, or a combination.
- Step 11** Click **OK** to create the bridge group.
- 

## Configuring an IP Address on an Inline Interface

You can assign IP addresses to the inline group interfaces, but it is not required. You can assign a primary IP address and up to four secondary IP addresses, using the procedure described in [Configuring Inline Interface Settings on WAEs](#).

You can set an inline group interface as the primary interface on the WAE by using the Configure > Network > Network Interfaces window, in the Primary Interface drop-down list.

In scenarios where the primary interface for a WAE is set to an inline group interface and management traffic is configured on a separate IP address (either on a secondary IP address on the same inline group interface or on a built-in interface), configure the WAAS Central Manager to communicate with the WAE on the IP address designated for management traffic. Configure the WAE management interface settings with the Configure > Network > Management Interface Settings menu item. For WAAS versions earlier than 5.0, configure the WAE management traffic IP address in the *device-name* > Activation window, in the Management IP field.

If a WAE operating in inline mode is present in an 802.1Q VLAN trunk line between a switch and a router, and you are configuring the inline interface with an IP address, you must set the VLAN ID that is to be assigned to the traffic that leaves the WAE. The VLAN ID should be set to match the VLAN ID expected by the router.

Use the **encapsulation dot1Q** interface command to assign a VLAN ID, as follows:

```
(config)# interface inlineGroup 1/0
(config-if)# encapsulation dot1Q 100
```

This example shows how to assign VLAN ID 100 to the traffic leaving the WAE. The VLAN ID can range from 1 to 4094.



**Note**

You can set the VLAN ID of the inline traffic by using the **encapsulation dot1Q** interface command or by using the Central Manager menu item **Configure > Interception > Interception Configuration** (see [Configuring Inline Interface Settings on WAEs](#)).

If the VLAN ID that you set does not match the VLAN ID expected by the router subinterface, you may not be able to connect to the inline interface IP address.

The inline adapter supports only a single VLAN ID for each inline group interface. If you have configured a secondary address from a different subnet on an inline interface, you must have the same secondary address assigned on the router subinterface for the VLAN.

Using IEEE 802.1Q tunneling increases the frame size by 4 bytes when the tag is added. Therefore, you must configure all the switches through which the tunneled packet traverses to be able to process larger frames by increasing the device MTU to at least 1504 bytes.

**Note**

When an Inline interface on a WAE configured with IPv6 address and dot1 q encapsulation, tries to communicate with an IPv6 default gateway, the communication fails. If the same device, configured with IPv4 address and dot1 Q encapsulation, tries to communicate with an IPv4 default gateway, the communication is successful.

Note that when dot1Q encapsulation is disabled, the WAE (configured with either IPv6 or IPv4) can successfully reach the default gateway of the relevant IP type.

The following operating considerations apply to configuring IP addresses on the inline interfaces:

- This feature provides basic routable interface support and does not support the following additional features associated with the built-in interfaces: standby and port channel.
- If you have configured a WAE to use inline interfaces for all traffic, inline interception must be enabled; otherwise, the WAE will not receive any traffic.
- If you have configured a WAE to use the inline interfaces for all traffic, and it goes into mechanical bypass mode, the WAE become inaccessible through the inline interface IP address. Console access is required for device management when an inline interface is in bypass mode.
- If you have configured a WAE with an IP address on an inline interface, the interface can accept only traffic addressed to it and ARP broadcasts, and the interface cannot accept multicast traffic.
- In a deployment using the Hot Standby Router Protocol (HSRP) where two routers that participate in an HSRP group are directly connected through two inline groups, HSRP works for all the clients if the active router fails. However, this redundancy does not apply to the IP address of the WAE itself for management traffic, if management traffic is also configured to use the inline interface. If the active router fails, you will not be able to connect to the WAE inline IP address because the inline interface is physically connected to the failed router interface. You will be able to connect to the WAE through the second inline group interface that is connected to the standby router. If redundancy is needed for the IP address of the WAE itself for management traffic, we recommend that you use the IP addresses of the built-in interfaces rather than the inline interfaces.



## Configuring VLANs for Inline Support

Initially, the WAE accepts traffic from all VLANs. You can configure the WAE to include or exclude traffic from certain VLANs; for excluded VLANs, traffic is bridged across the LAN/WAN interfaces in a group and is not processed.

To configure a VLAN for inline support, follow these steps:

- 
- Step 1** From the WAAS Central Manager menu, choose **Configure > Platform > Vlans**.
- The Vlans window appears, which lists the VLANs that are defined. From this list, you can perform the following tasks:
- Edit a VLAN by choosing it and clicking the **Edit** taskbar icon.
  - Delete a VLAN by choosing it and clicking the **Delete** taskbar icon.
  - Create a new VLAN as described in the following steps.
- Step 2** Click the **Add VLAN** taskbar icon. The VLAN pane appears.
- Step 3** In the Name field, enter a name for the VLAN list.
- Step 4** In the Ranges field, enter a list of one or more VLAN ranges. Separate each VLAN range from the next with a comma (but no space). This list of VLAN ranges can be included or excluded from optimization when you configure the inline interface group, as described in [Configuring Inline Interface Settings on WAEs](#). You cannot specify the term **native** in this field.
- Step 5** Click **OK**.
- 

This facility for creating VLAN lists is provided so that you can configure VLAN lists globally. You do not have to use this facility to configure VLANs for an inline interface. You can configure VLANs directly in the inline interface settings window, as described in [Configuring Inline Interface Settings on WAEs](#).

## Information About Clustering Inline WAEs

You can serially cluster two WAE devices that are operating in inline mode to provide higher availability in the data center if a device fails. If the current optimizing device fails, the inline group shuts down, or the device becomes overloaded, the second WAE device in the cluster provides the optimization services. Deploying WAE devices in a serial inline cluster for scaling or load balancing is not supported.

**Note**

Overload failover occurs on TFO overload, not overload of individual application accelerators, and it is intended for temporary overload protection. We do not recommend that you continually run a WAE in an overloaded state, frequently triggering overload failover.

---

A serial cluster consists of two WAE devices connected together sequentially in the traffic path. The WAN port of one device is connected to the LAN port of the next device, as shown in [Figure 5-9](#).

Figure 5-9 Inline Cluster

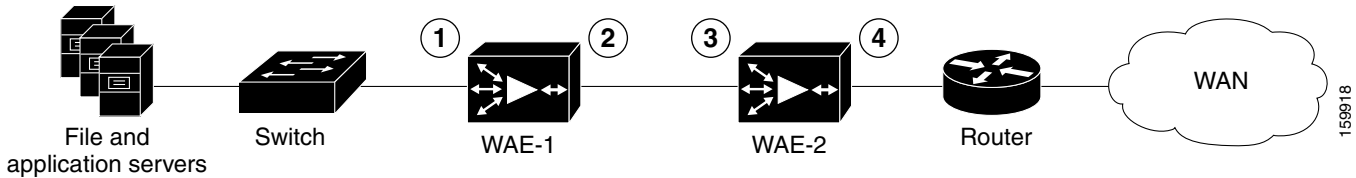

|          |                          |          |                          |
|----------|--------------------------|----------|--------------------------|
| <b>1</b> | Inline LAN port on WAE-1 | <b>3</b> | Inline LAN port on WAE-2 |
| <b>2</b> | Inline WAN port on WAE-1 | <b>4</b> | Inline WAN port on WAE-2 |

In a serial cluster, all the traffic between a switch and router passes through all the inline WAEs. In [Figure 5-9](#), TCP connections are optimized by WAE-1. If WAE-1 fails, it bypasses the traffic and connections are then optimized by WAE-2.

The policy configuration of serially clustered WAEs should be the same. Additionally, we recommend that you use the same device for both the WAEs in the cluster.

When serially clustering inline WAEs, on each WAE, you must configure the address of the other WAE in the cluster as a nonoptimizing peer. This disables optimization between the two peer WAEs in the serial cluster, since you want optimization only between the WAE peers on each side of the WAN link. For information on how to disable optimization between peers, see [Disabling Peer Optimization Between Serial Inline WAEs](#).

## Disabling Peer Optimization Between Serial Inline WAEs

To disable peer optimization between WAEs in a serial cluster, follow these steps:

- 
- Step 1** From the WAAS Central Manager menu, choose **Devices** > *device-name*. (You cannot configure peer settings from device groups.)
- Step 2** Choose **Configure** > **Peers** > **Peer Settings**.  
The Peer Settings window appears. (See [Figure 5-10](#).)

Figure 5-10 Peer Settings Window

Peer Settings for WAE, Ravi-03

Peer Settings

Current applied settings from WAE, Ravi-03

Disable Optimization

Disable Optimization With Peer: stress-ce-6

Automatically Configure Peer:

device name stress-ce-6

Description:

Some or all configuration on this page may not have any effect on the WAE (individual or part of device group) until it is upgraded to version 4.2.x or above

Filter:

| Select Peer                                  |                    |             |
|----------------------------------------------|--------------------|-------------|
| Device Name                                  | Hardware Device Id | Location    |
| <input type="radio"/> stress-ce-20           | 00:00:00:02:00:14  | location-20 |
| <input type="radio"/> stress-ce-3            | 00:00:00:02:00:03  | location-3  |
| <input type="radio"/> stress-ce-4            | 00:00:00:02:00:04  | location-4  |
| <input type="radio"/> stress-ce-5            | 00:00:00:02:00:05  | location-5  |
| <input checked="" type="radio"/> stress-ce-6 | 00:00:00:02:00:06  | location-6  |

Submit Cancel

- Step 3** Click the **Select Peer** triangle control to display the other WAEs that are registered with this Central Manager, in the lower part of the window (see the Select Peer area).
- Step 4** In the Select Peer area, click the radio button next to the serial peer of the current device. The peer device name appears in the Disable Optimization With Peer field.
- To filter the device list, enter a string in the Filter field. As you enter characters, the device list is dynamically filtered to include only devices that have the filter string in their name or hardware device ID.
- Step 5** Check the **Automatically Configure Peer** check box to allow the Central Manager to configure the other peer with a similar setting to disable optimization with the current device.
- If you do not check this check box, you must manually configure the other peer to disable optimization with the current device. After you submit your changes, you can click **Switch to Peer** to go to this same configuration page for the peer device.
- Step 6** In the Description field, enter a description for the peer. The default description is the device name of the peer.
- Step 7** Click **Submit**.

To disable serial peer optimization from the CLI, use the **no peer device-id** global configuration command. To re-enable serial peer optimization, use the **peer device-id** global configuration command.

To view the status of all the serial cluster pairs registered with the Central Manager, from the WAAS Central Manager menu, choose **Configure > Global > Peer Settings**. The Peer Settings status window appears, as shown in Figure 5-11.

Figure 5-11 Peer Settings For All Devices Window

| Where configured | Peer Device/Hardware Device Id  | Mutual Pair |
|------------------|---------------------------------|-------------|
| Ravi-02          | stress-ce-9 / 00:00:00:02:00:09 | ✓           |
| Ravi-03          | stress-ce-6 / 00:00:00:02:00:06 | ✓           |
| stress-ce-5      | Ravi-03 / 00:1a:64:d4:e0:4c     |             |
| stress-ce-6      | Ravi-03 / 00:1a:64:d4:e0:4c     | ✓           |
| stress-ce-7      | Ravi-03 / 00:1a:64:d4:e0:4c     |             |
| stress-ce-9      | Ravi-02 / 00:11:25:22:30:5b     | ✓           |

The window lists each WAE for which you have configured peer optimization settings. Verify that there are two entries for each serial cluster pair, both with a check mark in the Mutual Pair column. There should be an entry for each WAE in the pair, for example, the first and last entries in the figure.

If you see an entry without a check mark in the Mutual Pair column (like the third one in the figure), it indicates a WAE on which a serial peer is configured, but the peer is not similarly configured with the first device as its serial peer.

## Configuring AppNav Interception

For WAEs that are a part of an AppNav deployment and are configured as WAAS nodes (WNs) in an AppNav Cluster, you must configure them to use the appnav-controller interception method. These WNs receive traffic only from the ANCs, not directly from routers. It is on the ANC devices that you configure an interception method, such as WCCP, PBR, or inline to intercept network traffic. For more information about an AppNav deployment, see [Chapter 4, “Configuring AppNav.”](#)



### Note

ISR-WAAS devices support only the AppNav Controller interception method.

If you create an AppNav Cluster by using the Central Manager wizard, or you add WNs to a cluster through the AppNav Clusters window, the Central Manager automatically configures WNs with the appnav-controller interception method. After the WN is added to a cluster, its interception method cannot be changed.

To manually configure appnav-controller interception on a WN, follow these steps:

- Step 1** From the WAAS Central Manager menu, choose **Devices > device-name**.
- Step 2** Choose **Configure > Interception > Interception Configuration**. The Interception Configuration window appears.
- Step 3** From the Interception Method drop-down list, choose **appnav-controller** to enable the appnav-controller interception method.
- Step 4** Click **Submit**.



## Configuring Network Settings

This chapter describes how to configure basic network settings such as configuring additional network interfaces to support network traffic, creating port channel and standby interfaces, configuring optimization on Cisco Wide Area Application Services (WAAS) Express interfaces, specifying a default gateway and Domain Name System (DNS) servers, enabling the Cisco Discovery Protocol (CDP).



### Note

Throughout this chapter, the term Cisco WAAS device is used to refer collectively to the WAAS Central Managers and Cisco Wide Area Application Engines (WAEs) in your network. The term WAE refers to WAE and WAVE appliances, SM-SRE modules running WAAS, and Cisco Virtual WAAS (vWAAS) instances.

This chapter contains the following sections:

- [Configuring Network Interfaces](#)
- [Configuring TCP Settings](#)
- [Configuring a Static IP Route](#)
- [Configuring CDP Settings](#)
- [Configuring the DNS Server](#)
- [Configuring Windows Name Services](#)

For information on configuring a bridge group for inline interfaces on an AppNav Controller Interface Module, see [Configuring Inline Operation on ANCs](#) in Chapter 5, “Configuring Traffic Interception,” or use the AppNav Cluster wizard, as described in [Creating a New AppNav Cluster with the AppNav Cluster Wizard](#) in Chapter 4, “Configuring AppNav.”

## Configuring Network Interfaces

During initial setup, you choose an initial interface and either configure it for DHCP or gave it a static IP address, as described in the [Cisco Wide Area Application Services Quick Configuration Guide](#).

From release 6.0, the following devices support IPv4 only, IPv6 only and dual stack configuration.

- WAVE-294/594/694/7541/7571/8541
- vWAAS on VMware ESX and ESXi hypervisor, vWAAS on ISR 4451(kWAAS)
- WAAS Express

This section describes how to configure additional interfaces using options for redundancy, load balancing, and performance optimization and also to modify previously configured settings on interfaces.

This section contains the following topics:

- [Configuring a Standby Interface](#)
- [Configuring Multiple IP Addresses on a Single Interface](#)
- [Modifying Ethernet Interface Settings](#)
- [Configuring the Default Gateway](#)
- [Configuring Port-Channel Settings](#)
- [Configuring Interfaces for DHCP](#)
- [Modifying Virtual Interface Settings for a vWAAS Device](#)
- [Enabling or Disabling Optimization on WAAS Express Interfaces](#)
- [Enabling WAAS Service Insertion on AppNav-XE Device Interfaces](#)
- [Configuring Management Interface Settings](#)
- [Configuring Management Interface Settings](#)
- [Configuring a Jumbo MTU](#)

We recommend that you use the WAAS Central Manager instead of the WAAS CLI to configure network settings. If you want to use the CLI, see the following commands in the *Cisco Wide Area Application Services Command Reference*: **interface**, **ip address**, **port-channel**, and **primary-interface**.

Network interfaces are named as follows on WAAS devices:

- WAE-512/612/7326—Have two inbuilt Ethernet interfaces named GigabitEthernet 1/0 and GigabitEthernet 2/0.
- WAVE-294/594/694/7541/7571/8541—Have two inbuilt Ethernet interfaces named GigabitEthernet 0/0 and GigabitEthernet 0/1. Additional interfaces on the Cisco Interface Module and AppNav Controller Interface Module are named GigabitEthernet 1/0 to 1/11 or TenGigabitEthernet 1/0 to 1/3, depending on the number and type of ports.
- NME-WAE devices—Have an internal interface to the router that is designated 1/0, and an external interface that is designated 2/0. SM-SRE devices—Have an internal interface to the router that is designated 1/0 and an external interface that is designated 2/0.



**Note**

We strongly recommend that you do not use half-duplex connections on the WAE or on routers, switches, or other devices. Half duplex impedes performance and should not be used. Check each Cisco WAE interface and the port configuration on the adjacent device (router, switch, firewall, and WAE) to verify that full duplex is configured.

When connecting an AppNav Controller to a Cisco Nexus 7000 Series switch, the interfaces on both devices must be set to the same autonegotiate setting: either both on or both off. If they are set differently, switch-link flapping may occur.



**Note**

On Cisco ISR-WAAS devices, you cannot configure the following from the WAAS Central Manager: network interfaces, ip addresses (IPv4 or IPv6), routes, default gateway, DNS servers, and jumbo maximum transmission unit (MTU). Use the router CLI to configure these.

**Note**

Layer 3 interfaces may drop bridge protocol data unit (BPDU) packets. However, this does not affect data traffic.

**Note**

When a Central Manager and WAE are part of a dual stack configuration, the primary interface on the Central Manager must be configured with an IPv6 address. If this is not configured, then a device (configured with only an IPv6 address) fails to communicate with the Central Manager when it is registered to the CM; and goes into the offline state.

## Configuring a Standby Interface

Using this procedure, you can configure a logical interface called a standby interface. After you configure this standby interface, you must associate physical or port-channel interfaces with the standby interface in order to create a standby group. In the WAAS Central Manager, you can create a standby group by assigning two interfaces to the standby group and assigning one as primary.

Standby interfaces remain unused unless a member interface that is in use fails. When an in-use network interface fails (because of cable trouble, Layer 2 switch failure, or other failure), the other member interface of the standby group changes its state to in use and starts to carry traffic and take the load off the failed interface. With the standby interface configuration, only one interface is in use at a given time.

To configure standby interfaces, you must assign two physical or two port-channel interface members to a standby group. The following operating considerations apply to standby groups:

- A standby group consists of two physical or two port-channel interfaces. (If you are configuring a WAAS device running a version earlier than 5.0, both interfaces must be physical interfaces.)
- The maximum number of standby groups on a WAAS device is two. When using a Cisco AppNav Controller Interface Module, you can have up to three standby groups.
- A standby group is assigned a unique standby IP address, shared by all members of the group.
- Configuring the duplex and speed settings of the standby group member interfaces provides better reliability.
- IP ACLs can be configured on physical interfaces that are members of a standby group.
- One interface in a standby group is designated as the primary standby interface. Only the primary interface uses the group IP address.
- If the in-use interface fails, another interface in its standby group takes over and carries the traffic.
- If all the members of a standby group fail, and then one recovers, the WAAS software brings up the standby group on the operational interface.
- The primary interface in a standby group can be changed at runtime. (The default action is to pre-empt the currently in-use interface if a different interface is made primary.)
- If a physical interface is a member of a standby group, it cannot also be a member of a port channel.
- If a device has only two interfaces, you cannot assign an IP address to both a standby group and a port channel. On such a device, only one logical interface can be configured with an IP address.
- The member interfaces of a standby group can be connected to different switches if you use a VLAN tagging protocol and assign the same VLAN tag to each interface.
- You cannot include a built-in Ethernet port and a port on a Cisco Interface Module in the same standby group.

Configuring a standby interface differs, depending on the version of the WAAS device that you are configuring. See one of the following topics:

- [Configuring a Standby Interface on a Device with Version 5.0 or Later](#)
- [Configuring a Standby Interface on a Device Earlier than Version 5.0](#)

## Configuring a Standby Interface on a Device with Version 5.0 or Later

To configure a standby interface for devices with WAAS Version 5.0 or later, follow these steps:

**Step 1** From the WAAS Central Manager menu, choose **Devices** > *device-name*.

**Step 2** Choose **Configure** > **Network** > **Network Interfaces**.

The Network Interfaces window for the device appears. (See [Figure 6-1](#).)

**Figure 6-1** Network Interfaces for Device Window

The screenshot shows the 'Network Interfaces' configuration page in the WAAS Central Manager. At the top, there are navigation tabs: Home, Device Groups, Devices, AppNav Clusters, and Locations. The current device is 'CMSC3-BR1-WAE1'. Below the navigation, there are 'Print' and 'Refresh' icons. The 'Primary Interface Settings' section has two dropdown menus: 'IPv4 Primary Interface' set to 'None' and 'IPv6 Primary Interface' set to 'GigabitEthernet 0/0'. Below this is a table titled 'Network Interfaces' with columns: Interface, Status, IPv4 Address, IPv6 Address, Load Interval, Duplex/Speed, and Assigned To Int. Two interfaces are listed: 'GigabitEthernet 0 / 0' (UP, 2.78.18.67 / 255.255.255.240, 2077:2:2::10/64) and 'GigabitEthernet 0 / 1' (UP, 1.1.1.1 / 255.255.255.254). Below the table is a 'Logical Interface' section with a 'Create Logical Interface' icon and a table with columns: Interface, Status, IPv4 Address, IPv6 Address, Load Interval, and Contains Interfaces. One logical interface is listed: 'Standby 1' (Shutdown, 30 load interval).

**Step 3** In the taskbar of the lower area, click the **Create Logical Interface** icon.

The Create Logical Interface window appears.

**Step 4** From the Logical Interface Type drop-down list, choose **Standby** and click **OK**.

The window refreshes with fields for configuring the standby group settings.

**Step 5** From the Standby Group Number drop-down list, choose a group number for the interface.

**Step 6** (Optional) From the Bridge Group Number drop-down list, choose a bridge virtual interface (BVI) group number with which to associate this standby interface, or **None**. For more information on BVI, see [Configuring Management Interface Settings](#).



**Note** This configuration item is not supported on AppNav Controller Interface Module ports.

**Step 7** (Optional) In the Description field, enter a description for the standby group.



- Step 8** (Optional) Check the **Shutdown** check box to shut down the hardware interface. By default, this option is disabled.
- Step 9** (Optional) From the Load Interval drop-down list, choose the interval, in seconds, at which to poll the interface for statistics and calculate throughput. The default is 30 seconds.
- Step 10** In the Address field, specify the IP address of the standby group.
- Step 11** In the Netmask field, specify the netmask of the standby group.
- Step 12** Under **IPv6 Settings**, manually assign an IPv6 address to the primary interface or select from the following options. If you select one of the following options, the IPv6 address field and subsequent secondary IPv6 address fields are not available.
- Use Link Local - A unicast address that is automatically configured on an interface using the link-local prefix FE80::/10 and the interface identifier in the modified EUI-64 format. Using this address configuration option is sufficient for nodes on a link to communicate.
  - Use Auto Config - To auto-configure an IPv6 global unicast address on the interface as per RFC 4862.
- Step 13** In the Duplicate address Detection Attempts field enter a number between 0-600 to specify the number of attempts by which the duplicate address should be detected.
- Step 14** In the Assign Interfaces area, check the check boxes next to the two interfaces that you want to assign to this standby group and click the **Assign** taskbar icon. (To unassign any assigned interfaces, check the check box next to each interface that you want to unassign and click the **Unassign** taskbar icon.)
- If you want to have two port-channel interfaces as members of the standby group, do not assign any interfaces here. When you create the port-channel interfaces, you assign the standby group number in that window.
- Step 15** To assign one physical interface as the primary (active) interface in the standby group, ensure that it is the only interface that is checked, and then click the **Enable Primary** taskbar icon.
- Step 16** Click **OK**.
- 

## Configuring a Standby Interface on a Device Earlier than Version 5.0

To configure a standby interface for devices with WAAS versions earlier than 5.0, follow these steps:

---

- Step 1** From the WAAS Central Manager menu, choose **Devices > device-name**.
- Step 2** Choose **Configure > Network > Network Interfaces**.  
The Network Interfaces window for the device appears.
- Step 3** In the taskbar, click the **Create New Interface** icon.  
The Creating New Network Interface window appears.
- Step 4** From the Port Type drop-down list, choose **Standby**.  
The window refreshes with fields for configuring the standby group settings.
- Step 5** From the Standby Group Number drop-down list, choose a group number for the interface.
- Step 6** (Optional) In the Description field, enter a description for the standby group.
- Step 7** In the Address field, specify the IP address of the standby group.
- Step 8** In the Netmask field, specify the netmask of the standby group.

- Step 9** (Optional) Check the **Shutdown** check box to shut down the hardware interface. By default, this option is disabled.
- Step 10** In the Default Gateway field, enter the default gateway IP address. If an interface is configured for DHCP, then this field is read only.
- Step 11** (Optional) From the Bridge Group Number drop-down list, choose a bridge virtual interface (BVI) group number with which to associate this standby interface, or choose **None**. For more information on BVI, see [Configuring Management Interface Settings](#).
- Step 12** Click **Submit**.
- Step 13** Configure the physical interface members, as described in [Assigning Physical Interfaces to a Standby Group](#).



**Note** After you create the standby interface, assign two physical interfaces to the standby group.

### Assigning Physical Interfaces to a Standby Group

After you configure a logical standby interface for a device with a WAAS version earlier than 5.0, configure the standby group by assigning physical interfaces to the standby group and setting one physical interface as the primary standby interface. The primary interface in the standby group uses the standby group IP address. You must have a standby interface configured before you can set it as primary. (See [Configuring a Standby Interface](#).)

You can assign an interface to a standby group only if the interface does not have an IP address assigned, and uses the IP address of the standby group.



**Note** Removing a physical interface from standby group 2 on all WAAS device models may cause network disruption for up to 30 seconds. Additionally, removing a physical interface from standby group 1 on device model WAE-612 may cause network disruption for up to 30 seconds. The best practice is to make such changes when traffic interception is disabled, or at a time when traffic disruption is acceptable.

To associate an interface with a standby group and set it as the primary standby interface, follow these steps:

- Step 1** From the WAAS Central Manager menu, choose **Devices** > *device-name*.
- Step 2** Choose **Configure** > **Network** > **Network Interfaces**. The Network Interfaces window for the device appears.
- Step 3** Click the **Edit** icon next to the physical interface that you want to assign to a standby group. The Interface Settings window appears.



**Note** Choose a physical interface, not a logical interface (standby, port channel, or BVI), in this step.

- Step 4** Complete the following steps to assign the interface to a standby group and specify it as the primary standby interface:
- a. In the Port Type To Assign drop-down list, choose **Standby**.

- b. Check either the **Join Standby Group 1** or the **Join Standby Group 2** check box. (Only one check box is shown if only one standby interface has been defined.)
- c. (Optional) Check the **Standby Primary** check box if you want this physical interface to be the primary (active) interface in the standby group.

**Step 5** Click **Submit**.

---

## Configuring Multiple IP Addresses on a Single Interface

You can configure up to four secondary IP addresses on a single interface. This configuration allows the device to be present in more than one subnet and can be used to optimize the response time because it allows the data to go directly from the WAAS device to the client that is requesting the information without being redirected through a router. The WAAS device becomes visible to the client because both are configured on the same subnet.

Configuring multiple IP addresses is not supported on AppNav Controller Interface Module ports.

To configure multiple IP addresses on a single interface, follow these steps:

---

- Step 1** From the WAAS Central Manager menu, choose **Devices** > *device-name*.
- Step 2** Choose **Configure** > **Network** > **Network Interfaces**. The Network Interfaces listing window appears.
- Step 3** Choose the physical interface that you want to modify and click the **Edit** taskbar icon. (For devices using WAAS versions earlier than 5.0, click the **Edit** icon next to the interface.)

The Interface Settings window appears.



**Note** Do not choose a standby or port-channel interface in this step. You cannot configure multiple IP addresses on these types of interfaces.

---

- Step 4** In the Secondary Address and Secondary Netmask fields 1 through 4, enter up to four different IP addresses and secondary netmasks for the interface.
  - Step 5** Click **OK**. (For devices using WAAS versions earlier than 5.0, click **Submit**).
- 

## Modifying Ethernet Interface Settings

This section has two topics:

- [Modifying Physical Ethernet Interface Settings](#)
- [Configuring Flow Control on 1 GB/s and Faster Ethernet Ports](#)

### Modifying Physical Ethernet Interface Settings

To modify the settings of a physical Ethernet interface, follow these steps:

**Step 1** From the WAAS Central Manager menu, choose **Devices** > *device-name*.

**Step 2** Choose **Configure** > **Network** > **Network Interfaces**.

The Network Interfaces window appears, listing the configured network interfaces.



**Note** On NME-WAE devices, the internal interface to the router is designated slot 1, port 0, and the external interface is designated slot 2, port 0. For NME-WAE configuration details, see the document [Configuring Cisco WAAS Network Modules for Cisco Access Routers](#).

On ISR-WAAS devices you cannot configure the network interfaces from the Central Manager.

**Step 3** Choose the physical interface that you want to modify, and click the **Edit** taskbar icon. (For devices using WAAS versions earlier than 5.0, click the **Edit** icon next to the interface.)

The Interface Settings window appears, displaying the interface configurations on a particular slot and port. The interface type, slot, and port are determined by the hardware.



**Note** When configuring the internal interface (GigabitEthernet 1/0) on an NME-WAE device, you cannot change the following fields or check boxes: Port Channel Number, AutoSense, Speed, Mode, Address, Netmask, Use DHCP, and Standby Group. If you attempt to change these values, the Central Manager displays an error when you click **OK**. These settings for the internal interface can be configured only through the host router CLI. For NME-WAE details, see the document [Configuring Cisco WAAS Network Modules for Cisco Access Routers](#).

**Step 4** (Optional) In the Description field, enter a description for the interface.

**Step 5** (Optional) Check the **Use CDP** check box to enable the Cisco Discovery Protocol (CDP) on an interface.

When enabled, CDP obtains protocol addresses of neighboring devices and discovers the platform of those devices. It also shows information about the interfaces used by your router.

Configuring CDP from the CDP Settings window enables CDP globally on all the interfaces. For information on configuring CDP settings, see [Configuring CDP Settings](#).

**Step 6** (Optional) Check the **Shutdown** check box to shut down the hardware interface.

**Step 7** (Optional) From the Load Interval drop-down list, choose the interval, in seconds, at which to poll the interface for statistics and calculate throughput. The default is 30 seconds. (The Load Interval item is not shown for devices using WAAS versions earlier than 5.0.)

**Step 8** (Optional) Check the **AutoSense** check box to set the interface to autonegotiate the speed and mode. (This setting is not available on interfaces on some Cisco Interface Modules.)

Checking this check box disables the manual Speed and Mode drop-down list settings.



**Note** When autosense is on, manual configurations are overridden. You must reboot the WAAS device to start autosensing.

**Step 9** (Optional) Manually configure the interface transmission speed and mode settings as follows (these settings are not available on interfaces on some Cisco Interface Modules):

- a. Uncheck the **AutoSense** check box.
- b. From the Speed drop-down list, choose a transmission speed (10, 100, 1000, or 10000 Mbps). You must choose 1000 Mbps for fiber Gigabit Ethernet interfaces on a Cisco Interface Module.

- c. From the Mode drop-down list, choose a transmission mode (**full-duplex** or **half-duplex**). You must choose full-duplex for fiber Gigabit Ethernet interfaces on a Cisco Interface Module. This configuration item is not supported on AppNav Controller Interface Module ports.

Full-duplex transmission allows data to travel in both directions at the same time through an interface or a cable. A half-duplex setting ensures that data travels only in one direction at any given time. Although full duplex is faster, the interfaces sometimes cannot operate effectively in this mode. If you encounter excessive collisions or network errors, you may configure the interface for half duplex rather than full duplex.



---

**Note** We strongly recommend that you do not use half-duplex connections on the WAE or on routers, switches, or other devices. Half duplex impedes performance and should not be used. Check each Cisco WAE interface and the port configuration on the adjacent device (router, switch, firewall, and WAE) to verify that full duplex is configured.

---

- Step 10** Specify a value (in bytes) in the MTU field to set the interface MTU size.

The range is 576 to 1500 bytes. The MTU is the largest size of IP datagram that can be transferred using a specific data link connection.

If the interface has a IPv6 configuration, the MTU range is between 1280-1500 bytes.



---

**Note** The MTU field is not editable if the interface is assigned to a standby or port-channel group, or if a system jumbo MTU is configured.

---

- Step 11** (Optional) Check the **Use DHCP** check box to obtain an interface IP address through DHCP. Checking this box hides the IP address and Netmask fields. (For devices with WAAS versions earlier than 5.0, these fields are not hidden, but are disabled.) This configuration item is not supported on AppNav Controller Interface Module ports.

Optionally, supply a hostname in the Hostname field and a client ID in the Client Id field.

- Step 12** In the Address field, enter a new IP address to change the interface IP address.

- Step 13** In the Netmask field, enter a new netmask to change the interface netmask.

- Step 14** (Optional) Enter up to four secondary IP addresses and corresponding subnet masks in the Secondary Address and Secondary Netmask fields. These fields are not supported on AppNav Controller Interface Module ports.

Configuring multiple IP addresses allows the device to be present in more than one subnet and can be used to optimize the response time because it allows the data to go directly from the WAAS device to the client that is requesting the information without being redirected through a router. The WAAS device becomes visible to the client because both are configured on the same subnet.

- Step 15** In the Default Gateway field, enter the default gateway IP address. If an interface is configured for DHCP, this field is read only. (The Default Gateway field is not shown for devices using WAAS versions 5.0 or later; configure it as described in [Configuring the Default Gateway](#).)

- Step 16** (Optional) From the Inbound ACL drop-down list, choose an IP ACL to apply to inbound packets.

The drop-down list contains all the IP ACLs that you configured in the system.

- Step 17** (Optional) From the Outbound ACL drop-down list, choose an IP ACL to apply to outbound packets.

- Step 18** Under IPv6 Settings, manually assign an IPv6 address to the primary interface or select from the following options. If you select one of the following options, the IPv6 address field and subsequent secondary IPv6 address fields are not available.

- Use Link Local - A unicast address that is automatically configured on an interface using the link-local prefix FE80::/10 and the interface identifier in the modified EUI-64 format. Using this address configuration option is sufficient for nodes on a link to communicate.
- Use Auto Config - To auto-configure an IPv6 global unicast address on the interface as per RFC 4862.
- Use DHCP - To obtain an interface IP address through DHCP.

**Step 19** In the Duplicate address Detection Attempts field enter a number between 0-600 to specify the number of attempts by which the duplicate address should be detected.

**Step 20** Click **OK**. (For devices using WAAS versions earlier than 5.0, click **Submit**.)

**Note**

Changing the interface transmission speed, duplex mode, or MTU may cause network disruption for up to 30 seconds. The best practice is to make such changes when traffic interception is disabled or at a time when traffic disruption is acceptable.

## Configuring Flow Control on 1 GB/s and Faster Ethernet Ports

For Ethernet ports that run at 1 Gb/s or faster, you can enable or disable the port's ability to send and receive flow-control pause frames. For Ethernet ports that run slower than 1 Gb/s, you can enable or disable only the port's ability to receive flow-control pause frames.

**Note**

We recommend that you enable flow control on the Nexus 7000 and 6500 Series models when WAAS IOM onboard NIC are directly attached to the Nexus 7000 and 6500 Series models, and input packet drops are seen.

There are three options for enabling flow control for the local port:

- Fully enable the local port to send or receive frames regardless of the flow-control setting of the remote port,
- Set the local port to use the same setting you have specified for the remote port.
- Set a combination of the two states for the local and remote ports.

**Note**

If you enable flow control on both the local and the remote Ethernet port, or you set a specified flow control of the remote port only, or set a combination of these states—flow control is enabled for those ports.

**Note**

For Ethernet ports that run at 10 GB/s or faster, you cannot use the specified state for the send/receive parameter.

### *Before you configure flow control:*

Before you begin the following procedure, verify these conditions:

- Verify that the remote port that has the corresponding setting for the local port has the flow control that you need.

- If you want the local port to send flow-control pause frames, verify that the remote port has a Receive parameter set to **On** or **Desired**.
- If you want the local port to receive flow-control frames, verify that the remote port has a Send parameter set to **On** or **Desired**.
- If you do not want to use flow control, set the remote port's Send and Receive parameters to **Off**.

To configure flow control for 1 GB/s and faster Ethernet ports, follow these steps:

- 
- Step 1** Enter Configuration mode for the terminal, using the **config terminal** command.
- Step 2** Specify an Ethernet interface to configure, using the **interface ethernet slot/port** command. The **interface ethernet slot/port** command enters the terminal into Interface Configuration mode.
- Step 3** Specify the flow-control setting for ports, using the **flowcontrol** command. Parameters for this command are **send/receive** and **desired/on/off**.
- You can set the Send parameter only for ports running at 1000 MB/s or faster.
  - You can set the Receive parameter for ports running at any speed.
- Step 4** Display the interface status, using the **show interface gigabitEthernet slot/port** command. The interface status includes the flow-control parameters. The following is sample output from the **show interface gigabitEthernet slot/port** command:
- ```
#show interface gigabitEthernet 0/1

Ethernet Address           : 50:3d:e5:9d:1c:ef
Internet Address          : --
Netmask                   : --
Admin State               : Up
Operation State           : Running
Maximum Transfer Unit Size : 1500
Input Errors              : 2
Input Packets Dropped     : 41967568
Packets Received          : 218840605830
Output Errors             : 0
Output Packets Dropped    : 0
Load Interval             : 30
Input Throughput          : 364402648 bits/sec, 45090 packets/sec
Output Throughput         : 191939420 bits/sec, 23974 packets/sec
Packets Sent              : 161861463575
```
- Step 5** Display the flow control status for all Ethernet ports, using the **show interface flowcontrol** command.
- Step 6** Exit Interface mode, using the **exit** command.
- Step 7** (Optional) Copy the running configuration to the startup configuration, using the **copy running-config startup-config** command.
-

Configuring the Default Gateway

On WAAS devices with Version 5.0 or later, configure the default gateway as follows:

-
- Step 1** From the WAAS Central Manager menu, choose **Devices** > *device-name*.
- Step 2** Choose **Configure** > **Network** > **Default Gateway**.
The Default Gateway window appears with fields for IPv4 and IPv6.
- Step 3** In the Default Gateway field, enter the default gateway IP address(either IPv4 or IPv6 address).
- Step 4** Click **Submit**.
-

To configure a default gateway from the CLI, use the **ip default-gateway** global configuration or the **ipv6 default-gateway address** command.

On WAAS devices with versions earlier than 5.0, the default gateway should be configured within the interface settings for each interface.

**Note**

On ISR-WAAS devices, you cannot configure the default gateway from the Central Manager.

Configuring Port-Channel Settings

The WAAS software supports grouping of up to four (eight on AppNav Controller Interface Modules) physical network interfaces into one logical interface called a port channel. After you configure this port-channel interface, you must associate physical interfaces with the port channel.

You can configure up to four port-channel interfaces (seven on AppNav Controller Interface Modules). This capability also provides interoperability with Cisco routers, switches, and other networking devices or hosts supporting EtherChannel, load balancing, automatic failure detection, and recovery based on each interface's current link status. EtherChannel is also referred to as a port channel.

You can use a port channel in standby interface, or as a member of an inline bridge group on an AppNav Controller Interface Module. For more information on configuring a BVI, see [Configuring Management Interface Settings](#). The following operating considerations apply to a port-channel virtual interface:

- A physical interface can be a member of a port channel or a standby group, but not both.
- You cannot assign an IP address to both a port channel and a standby group. Only one logical interface can be configured with an IP address.
- All port-channel member interfaces must have the same port bandwidth.
- Port-channel settings are not applicable to vWAAS devices.
- You cannot include a built-in Ethernet port and a port on a Cisco Interface Module in the same port-channel interface.

**Note**

You must disable autoregistration if the device has only two interfaces and both device interfaces are configured as port-channel interfaces.

Configuring a port-channel interface differs, depending on the version of the WAAS device that you are configuring. See one of the following topics:

- [Configuring a Port-Channel Interface on a Device with Version 5.0 or Later](#)
- [Configuring a Port-Channel Interface on a Device Earlier than Version 5.0](#)

Configuring a Port-Channel Interface on a Device with Version 5.0 or Later

To configure a port-channel interface for devices with WAAS Version 5.0 or later, follow these steps:

-
- Step 1** From the WAAS Central Manager menu, choose **Devices** > *device-name*.
- Step 2** Choose **Configure** > **Network** > **Network Interfaces**. The Network Interfaces window for the device appears.
- Step 3** In the taskbar of the lower area, click the **Create Logical Interface** icon. The Create Logical Interface window appears.
- Step 4** From the Logical Interface Type drop-down list, choose **PortChannel** and click **OK**. The window refreshes with fields for configuring the port-channel interface settings.
- Step 5** From the Port Channel Number drop-down list, choose a number for the interface.
- Step 6** (Optional) From the Bridge Group Number drop-down list, choose a bridge group number with which to associate this interface, or choose **None**. The bridge group number can be associated with a BVI or an inline bridge group defined on an AppNav Controller.
- Step 7** (Optional) From the Standby Group Number drop-down list, choose a standby group number with which to associate this interface, or choose **None**.
- You must create the standby group with no assigned interfaces before it appears as a choice in this list.
- Step 8** (Optional) In the Description field, enter a description for the interface.
- Step 9** (Optional) Check the **Shutdown** check box to shut down the hardware interface. By default, this option is disabled.
- If you plan to assign this port-channel interface to a standby interface, check this check box.
- Step 10** (Optional) From the Load Interval drop-down list, choose the interval, in seconds, at which to poll the interface for statistics and calculate throughput. The default is 30 seconds.
- Step 11** In the Address field, specify the IP address of the interface.
- If you are assigning this port-channel interface to a standby group, do not configure an IP address or netmask. The standby group supplies the IP address and netmask.
- Step 12** In the Netmask field, specify the netmask of the interface.
- Step 13** (Optional) From the Inbound ACL drop-down list, choose an IP ACL to apply to inbound packets. The drop-down list contains all the IP ACLs that you configured in the system.
- Step 14** (Optional) From the Outbound ACL drop-down list, choose an IP ACL to apply to outbound packets.
- Step 15** Under IPv6 Settings, manually assign an IPv6 address to the primary interface or select from the following options. If you select one of the following options, the IPv6 address field and subsequent secondary IPv6 address fields are not available.
- Use Link Local - A unicast address that is automatically configured on an interface using the link-local prefix FE80::/10 and the interface identifier in the modified EUI-64 format. Using this address configuration option is sufficient for nodes on a link to communicate.
 - Use Auto Config - To auto-configure an IPv6 global unicast address on the interface as per RFC 4862.
- Step 16** In the Duplicate address Detection Attempts field enter a number between 0-600 to specify the number of attempts by which the duplicate address should be detected.

Step 17 In the Assign Interfaces area, click the check box next to the interfaces that you want to assign to this port channel and click the **Assign** taskbar icon. To unassign assigned interfaces, check the check box next to each interface that you want to unassign and click the **Unassign** taskbar icon.

If you plan to assign this port-channel interface to a standby interface, do not assign interfaces until after the port channel is assigned to the standby interface.

Step 18 Click **OK**.

Configuring a Port-Channel Interface on a Device Earlier than Version 5.0

To configure a port-channel interface for devices with WAAS versions earlier than 5.0, follow these steps:

-
- Step 1** From the WAAS Central Manager menu, choose **Devices** > *device-name*.
 - Step 2** Choose **Configure** > **Network** > **Network Interfaces**. The Network Interfaces window appears, listing all the interfaces for the chosen device.
 - Step 3** In the taskbar, click the **Create New Interface** icon. The Creating New Network Interface window appears.
 - Step 4** From the Port Type drop-down list, choose **PortChannel**.
The window refreshes and provides fields for configuring the network interface settings.
 - Step 5** From the Port Channel Number drop-down list, choose the number of the port-channel interface. Up to four port channels are supported, depending on the WAAS device model and installed interface module.
 - Step 6** (Optional) In the Description field, enter a description for the port channel.
 - Step 7** (Optional) Check the **Shutdown** check box to shut down this interface. By default, this option is disabled.
 - Step 8** In the Default Gateway field, enter the default gateway IP address.
 - Step 9** In the Address field, specify the IP address of the interface.
 - Step 10** In the Netmask field, specify the netmask of the interface.
 - Step 11** (Optional) From the Inbound ACL drop-down list, choose an IP ACL to apply to inbound packets.
The drop-down list contains all the IP ACLs that you configured in the system.
 - Step 12** (Optional) From the Outbound ACL drop-down list, choose an IP ACL to apply to outbound packets.
 - Step 13** Click **Submit**.
 - Step 14** Configure the physical interface members as described in [Assigning Physical Interfaces to a Port Channel](#).
-



Note After you create the port-channel interface, assign physical interfaces to the port channel.

Assigning Physical Interfaces to a Port Channel

After you have configured a logical port-channel interface, you must assign multiple physical interfaces to the port channel. You can assign up to four physical interfaces to one port-channel interface, depending on the WAAS device.

You can assign an interface to a port channel only if the interface does not have an IP address assigned, and uses the IP address of the port channel.

You cannot combine built-in Ethernet ports with ports on a Cisco Interface Module into the same port-channel interface.

**Note**

Removing a physical interface from a port channel on device model WAE-612 may cause network disruption for up to 30 seconds. The best practice is to make such changes when traffic interception is disabled or at a time when traffic disruption is acceptable.

To add an interface to a port channel, follow these steps:

-
- Step 1** From the WAAS Central Manager menu, choose **Devices** > *device-name*.
 - Step 2** Choose **Configure** > **Network** > **Network Interfaces**. The Network Interfaces window for the device appears.
 - Step 3** Click the **Edit** icon next to the physical interface that you want to assign to a port channel. The Modifying Network Interface window appears.
Choose a physical interface, not a logical interface (standby, port channel, or BVI), in this step.
 - Step 4** Complete the following steps to assign the interface to a port channel:
 - a. From the Port Type To Assign drop-down list, choose **PortChannel**.
 - b. From the Port Channel Number drop-down list, choose the number of the port channel to which you want to add the physical interface.
 - Step 5** Click **Submit**.
-

Configuring a Load-Balancing Method for Port-Channel Interfaces

Before you configure load balancing, ensure that you have configured the port-channel settings described in [Configuring Port-Channel Settings](#).

To configure load balancing, follow these steps:

-
- Step 1** From the WAAS Central Manager menu, choose **Devices** > *device-name* (or **Device Groups** > *device-group-name*).
 - Step 2** Choose **Configure** > **Network** > **Port Channel**.
 - Step 3** From the Load Balancing Method drop-down list, choose a load-balancing method:
 - **src-dst-ip-port**—The distribution function is based on a combination of source and destination IP addresses and ports. This load-balancing method is available only on devices running Version 4.4.1 and later.
 - **src-dst-ip**—The distribution function is based on a combination of source and destination IP addresses. This load-balancing method is available only on devices running Version 5.0.1 and later.

- round-robin—Round robin allows traffic to be distributed evenly among all the interfaces in the channel group. This load-balancing method is available only on devices running versions earlier than 4.4.1.

Step 4 Click **Submit**.

To configure a load-balancing method from the CLI, use the **port-channel** global configuration command.



Note

To configure devices running previous versions of WAAS, a device group can be configured with a load-balancing method supported only by previous WAAS software versions. When viewing the Port Channel Settings window for Version 4.4.1 or later for a device that gets its settings from such a device group, you may see an unsupported load-balancing method listed. However, a Version 4.4.1 or later device supports only the load-balancing methods as described above, regardless of what the device group or device configuration window shows for the setting.

Configuring Interfaces for DHCP



Note

You must disable autoregistration before you can manually configure an interface for DHCP.

A WAAS device sends its configured client identifier and hostname to the DHCP server when requesting network information. You can configure DHCP servers to identify the client identifier information and the hostname information that the WAAS device is sending and then to send back the specific network settings that are assigned to the WAAS device.

To enable an interface for DHCP, follow these steps:

-
- Step 1** From the WAAS Central Manager menu, choose **Devices** > *device-name*.
- Step 2** Choose **Configure** > **Network** > **Network Interfaces**. The Network Interfaces listing window appears.
- Step 3** Choose the physical interface that you want to modify and click the **Edit** taskbar icon. (For devices using WAAS versions earlier than 5.0, click the **Edit** icon next to the interface.)

The Interface Settings window appears.



Note

Do not choose a logical interface (standby, port channel, or BVI) in this step, because you cannot configure DHCP on a logical interface. In addition, do not choose the internal interface (GigabitEthernet 1/0) on an NME-WAE module, because this interface can be configured only through the host router CLI. For NME-WAE details, see the document *Configuring Cisco WAAS Network Modules for Cisco Access Routers*. For SM-SRE details, see the document *Cisco SRE Service Module Configuration and Installation Guide*.

- Step 4** Check the **Use DHCP** check box.
- When this check box is checked, the IP address and netmask fields are disabled.
- Step 5** In the Hostname field, specify the hostname for the WAAS device or other device.
- Step 6** In the Client ID field, specify the configured client identifier for the device.

The DHCP server uses this identifier when the WAAS device requests the network information for the device.

Step 7 Click **Submit**.

Modifying Virtual Interface Settings for a vWAAS Device

To modify the settings of an existing vWAAS interface, follow these steps:

Step 1 From the WAAS Central Manager menu, choose **Devices** > *device-name*.



Note On ISR-WAAS devices you cannot configure the virtual interface settings from the Central Manager.

Step 2 Choose **Configure** > **Network** > **Network Interfaces**.

The Network Interfaces window appears, listing the network interfaces configured.



Note Certain values (including autosense) are not applicable to a vWAAS interface.

Step 3 Choose the interface that you want to modify and click the **Edit** taskbar icon. (For devices using WAAS versions earlier than 5.0, click the **Edit** icon next to the interface.)

The Interface Settings window appears, displaying the interface configurations on a particular slot and port.



Note Interface configurations for slot, port, and port type are set for virtual interfaces during initial startup, or by using the WAAS CLI.

Some of the fields in the window (port-channel number, autosense, speed, mode, and standby-related fields) are not available because they are not applicable.

Step 4 (Optional) In the Description field, enter a description for the interface.

Step 5 (Optional) Check the **Use CDP** check box to enable the Cisco Discovery Protocol (CDP) on an interface.

When enabled, CDP obtains protocol addresses of neighboring devices and discovers the platform of those devices. It also shows information about the interfaces used by your router.

Configuring CDP from the CDP Settings window enables CDP globally on all the interfaces. For information on configuring CDP settings, see [Configuring CDP Settings](#).

Step 6 (Optional) Check the **Shutdown** check box to shut down the virtual interface.

Step 7 (Optional) From the Load Interval drop-down list, choose the interval, in seconds, at which to poll the interface for statistics and calculate throughput. The default is 30 seconds. (The Load Interval item is not shown for devices using WAAS versions earlier than 5.0.)

Step 8 Specify a value (in bytes) in the MTU field to set the interface MTU size.

The range is 576 to 1500 bytes. The MTU is the largest size of IP datagram that can be transferred using a specific data link connection.

If the interface has a IPv6 configuration, the MTU range is between 1280-1500 bytes.



Note The MTU field is not editable if a system jumbo MTU is configured.

- Step 9** Check the **Use DHCP** check box to obtain an interface IP address through DHCP. Checking this check box hides the IP address and Netmask fields. (For devices with WAAS versions earlier than 5.0, these fields are not hidden but are disabled.)
- a. (Optional) In the Hostname field, specify the hostname for the WAAS device or other device.
 - b. (Optional) In the Client Id field, specify the configured client identifier for the device. The DHCP server uses this identifier when the WAAS device requests the network information for the device.
- Step 10** In the Address field, enter a new IP address to change the interface IP address.
- Step 11** In the Netmask field, enter a new netmask to change the interface netmask.
- Step 12** In the Default Gateway field, enter the default gateway IP address. The gateway interface IP address should be in the same network as one of the device's network interfaces. If an interface is configured for DHCP, this field is read only. (The Default Gateway field is not shown for devices using WAAS versions 5.0 or later; instead, configure it, as described in [Configuring the Default Gateway](#).)
- Step 13** (Optional) From the Inbound ACL drop-down list, choose an IP ACL to apply to inbound packets. The drop-down list contains all the IP ACLs that you configured in the system.
- Step 14** (Optional) From the Outbound ACL drop-down list, choose an IP ACL to apply to outbound packets.
- Step 15** Under IPv6 Settings, manually assign an IPv6 address to the primary interface or select from the following options.
- Use Link Local - A unicast address that is automatically configured on an interface using the link-local prefix FE80::/10 and the interface identifier in the modified EUI-64 format. Using this address configuration option is sufficient for nodes on a link to communicate.
 - Use Auto Config - To auto-configure an IPv6 global unicast address on the interface as per RFC 4862.
 - Use DHCP - To obtain an interface IP address through DHCP.
- Step 16** In the Duplicate address Detection Attempts field enter a number between 0-600 to specify the number of attempts by which the duplicate address should be detected.
- Step 17** Click **OK**. (For devices using WAAS versions earlier than 5.0, click **Submit**.)
-

Enabling or Disabling Optimization on WAAS Express Interfaces

WAAS Express device interfaces are configured by using the router CLI, not through the WAAS Central Manager. However, you can enable or disable WAAS optimization on the available interfaces on the router.

To enable or disable WAAS optimization on WAAS Express device interfaces, follow these steps:

- Step 1** From the WAAS Central Manager menu, choose **Devices** > *WAAS-Express-device-name* (or **Device Groups** > *WAAS-Express-device-group-name*).
- Step 2** Choose **Configure** > **Network** > **Network Interfaces**. The Network Interfaces window appears and lists the available interfaces. (See [Figure 6-2](#).)



Note Loopback interfaces are not included because they are not valid interfaces for optimization. Null, Virtual-Access, NVI, and Embedded-Service interfaces are also not supported.

Figure 6-2 WAAS Express Network Interfaces Device Window

Name	Address	Subnet	Speed	Duplex	Shutdown	Optimization
<input type="checkbox"/> GigabitEthernet0/0	10.104.227.122	255.255.255.128	100Mbps	Full	Yes	Disabled
<input type="checkbox"/> GigabitEthernet0/1			Auto	Auto	No	Enabled
<input type="checkbox"/> GigabitEthernet0/2			Auto	Auto	No	Disabled
<input type="checkbox"/> SM1/0			1Gbps	Full	No	Disabled
<input type="checkbox"/> SM1/1			Auto-speed	Auto	Yes	Disabled
<input type="checkbox"/> Vlan1					Yes	Disabled

For a device group, the Network Interfaces window is different and displays an interface name, the number of devices that contain that interface, and the number of devices in the group that have optimization enabled on the interface. (See [Figure 6-3](#).)

Figure 6-3 WAAS Express Network Interfaces Device Group Interfaces Window

Name	Number of Devices	Number of Optimization Enabled Devices
<input type="checkbox"/> GigabitEthernet0/1	2	1
<input type="checkbox"/> GigabitEthernet0/2	2	0
<input type="checkbox"/> GigabitEthernet0/0	2	0
<input type="checkbox"/> SM1/0	2	0
<input type="checkbox"/> SM1/1	2	0
<input type="checkbox"/> Vlan1	2	0

- Step 3** Check the check box next to each interface on which you want to enable WAAS optimization, and click the **Enable Optimization** taskbar icon; or, to disable optimization, click the **Disable Optimization** taskbar icon.



Note Enable WAAS optimization only on WAN interfaces, not LAN interfaces.

For a device group, enabling optimization for an interface enables optimization on that interface for all the devices in the group that have the interface. You can check the check box next to a single device and click the **Edit** taskbar icon to display a list of devices on which an interface is available and individually configure optimization on those devices. (See [Figure 6-4](#).)

Figure 6-4 WAAS Express Network Interfaces Device Group Devices Window

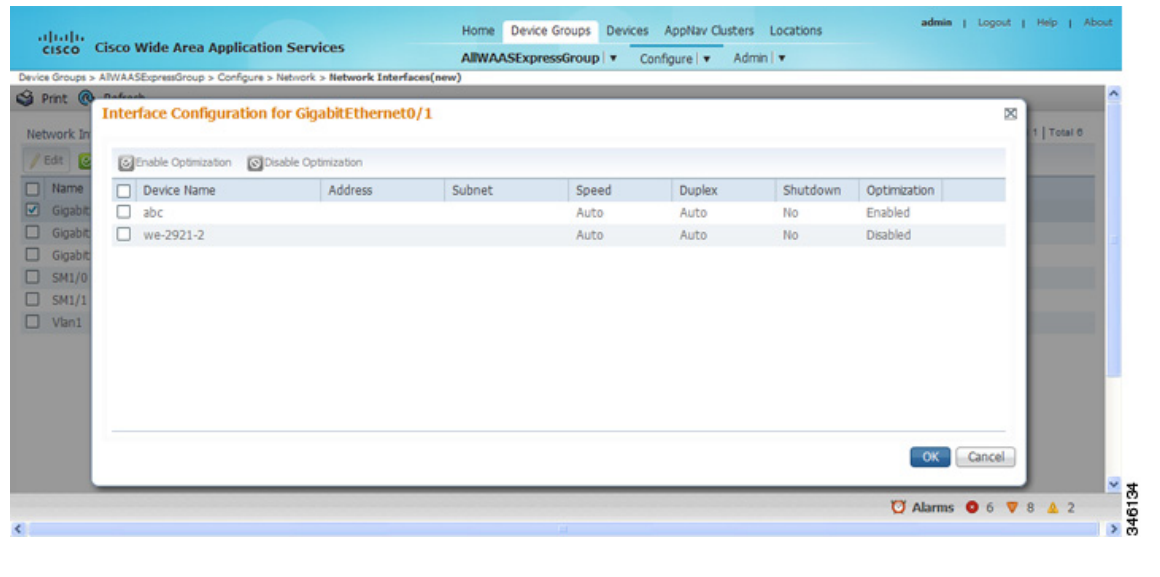

Enabling WAAS Service Insertion on AppNav-XE Device Interfaces

AppNav-XE device interfaces are configured by using the router CLI, not through the WAAS Central Manager. However, you can use the Central Manager to enable or disable WAAS service insertion on the available interfaces on the router.

To enable or disable WAAS service insertion on AppNav-XE device interfaces, follow these steps:

- Step 1** From the WAAS Central Manager menu, choose **Devices** > *AppNav-XE-device-name*.
- Step 2** Choose **Configure** > **Network** > **Network Interfaces**. The Network Interfaces window appears and lists the available interfaces.
- Step 3** Check the check box next to an interface on which you want to enable WAAS service insertion and click the **Edit** taskbar icon.
- Step 4** Check the **Enable WAAS Service Insertion** check box; or, to disable optimization, uncheck the check box.
Enable WAAS service insertion only on WAN interfaces, not LAN interfaces.
- Step 5** Click **OK**.
- Step 6** Repeat Step 3 through Step 5 for each interface on which you want to enable WAAS service insertion.

For more information about AppNav, see [Chapter 4](#), “Configuring AppNav.”

Configuring Management Interface Settings

On devices running WAAS Version 5.0 or later, you can designate a specific interface to be used as the management interface for communicating with the Central Manager, Telnet, SSH, and so on. This configuration separates management traffic from data traffic.

If you designate a management interface, you must have another active interface to handle data traffic. In addition to management interface for IPv4 traffic, a separate management interface can be configured for IPV6 traffic. This interface will use the management features with IPV6 support.

To configure the management interface settings, follow these steps:

-
- Step 1** From the WAAS Central Manager menu, choose **Devices** > *device-name*.
 - Step 2** Choose **Configure** > **Network** > **Management Interface Settings**.
The Management Interface Settings window appears with tabs for IPv4 and IPv6 settings. Select the appropriate one for your network before you proceed.
 - Step 3** From the Management Interface drop-down list, choose the interface that you want to use as the management interface.
 - Step 4** In the Management Default Gateway field, enter the default gateway IP address for management traffic.
 - Step 5** Check the **Use Management Interface for FTP Traffic** check box if you want to use the designated management interface for FTP traffic.
 - Step 6** Check the **Use Management Interface for TFTP Traffic** check box to use the designated management interface for TFTP traffic.
 - Step 7** Check the **Use Management Interface for Tacacs Traffic** check box to use the designated management interface for TACACS traffic.
 - Step 8** Check the **Use Management Interface for Radius Traffic** check box to use the designated management interface for RADIUS traffic.
 - Step 9** Check the **Use Management Interface for DNS Traffic** check box to use the designated management interface for DNS traffic.
 - Step 10** Check the **Use Management Interface for NTP Traffic** check box to use the designated management interface for NTP traffic.
 - Step 11** Click **Submit**. A confirmation message appears.
 - Step 12** Click **OK**.
-

To configure a different default gateway for management traffic from the CLI, use the **ip default-gateway management** global configuration command.

After you have designate a management interface, create static IP routes for management traffic so that an IP packet that is designated for the specified destination uses the configured route.

To configure a static route for management traffic, follow these steps:

-
- Step 1** In the Management Interface Settings window, in the Management IP Routes area of this window, click the **Create Management IP Route** taskbar button. The Management IP Routes window appears.
 - Step 2** In the Destination Network Address field, enter the destination network IP address.
 - Step 3** In the Netmask field, enter the destination host netmask. This field is not available when you create a IPv6 Management IP Route.

- Step 4** In the Gateway's IP Address field, enter the IP address of the gateway interface.
The gateway interface IP address should be in the same network as the device's management interface.
- Step 5** Click **Submit**.

To configure a static route for management traffic from the CLI, use the **ip route management** global configuration command.

Configuring a Jumbo MTU

A jumbo MTU can be configured on the following devices: WAVE-294/594/694/7541/7571/8541, and vWAAS.



Note

To enable Jumbo MTU on ISR-WAAS devices, first we need to upgrade the ISR-WAAS to version 6.0 using the .ova files. The default MTU size for the virtual interface of the ISR-WAAS devices is 9000 and cannot be changed.

If configured, a jumbo MTU applies to all the device interfaces, including logical interfaces with at least one member physical interface. The MTU for individual interfaces cannot be changed while the jumbo MTU is configured. If the jumbo MTU is disabled, all the interfaces are configured with an MTU of 1500.

To configure a jumbo MTU, follow these steps:

- Step 1** From the WAAS Central Manager menu, choose **Devices > device-name**.
- Step 2** Choose **Configure > Network > Jumbo MTU**.
The Jumbo MTU Settings window appears.
- Step 3** In the System Jumbo MTU field, enter the jumbo MTU size, in bytes, (maximum size varies by platform).
- Step 4** Click **Submit**.



Note

If the original and optimized maximum segment sizes are set to their default values and you configure a jumbo MTU setting, the segment sizes are changed to the jumbo MTU setting minus 68 bytes. If you have configured custom maximum segment sizes, their values are not changed if you configure a jumbo MTU. For more information on configuring maximum segment sizes, see [Modifying the Acceleration TCP Settings](#) in Chapter 12, "Configuring Application Acceleration."

To configure a jumbo MTU from the CLI, you can use the **system jumbomtu** global configuration command.

Configuring TCP Settings

For data transactions and queries between client and servers, the size of windows and buffers is important. Therefore, fine-tuning the TCP stack parameters becomes the key to maximizing cache performance.

Note

Because of the complexities involved in TCP parameters, be careful when tuning these parameters. In nearly all environments, the default TCP settings are adequate. Fine-tuning TCP settings is for network administrators with adequate experience and full understanding of TCP operation details.

To configure TCP and IP settings, follow these steps:

- Step 1** From the WAAS Central Manager menu, choose **Devices** > *device-name* (or **Device Groups** > *device-group-name*).
- Step 2** Choose **Configure** > **Network** > **TCP/IP Settings** > **TCP/IP**. The TCP/IP Settings window appears.
- Step 3** Make the necessary changes to the TCP settings.
See [Table 6-1](#) for a description of each TCP field in this window.
- Step 4** Click **Submit**.

A **click submit to save** message appears in red next to the Current Settings line when there are pending changes to be saved after you have applied default or device group settings. You can also revert to the previously configured settings by clicking **Reset**, which is visible only when you have applied default or group settings to change the current device settings, but have not yet submitted the changes.

Table 6-1 TCP Settings

TCP Setting	Description
TCP General Settings	
Enable Explicit Congestion Notification	Enables reduction of delay and packet loss in data transmissions. Provides TCP support for RFC 2581. By default, this option is enabled. For more information, see Explicit Congestion Notification .
Initial Send Congestion Window Size	Initial congestion window size value, in segments. The range is 0 to 10 segments. The default is 0 segment. For more information, see Congestion Windows .
ReTransmit Time Multiplier	Factor used to modify the length of the retransmit timer by 1 to 3 times the base value determined by the TCP algorithm. The default is 1, which leaves the times unchanged. The range is 1 to 3. For more information, see Retransmit Time Multiplier .
	<p>Note Modify this factor with caution. It can improve throughput when TCP is used over slow reliable connections, but should never be changed in an unreliable packet delivery environment.</p>

Table 6-1 TCP Settings (continued)

TCP Setting	Description
Keepalive Probe Count	Number of times that the WAAS device can retry a connection before the connection is considered unsuccessful. The range is 1 to 120 attempts. The default is 4 attempts.
Keepalive Probe Interval	Length of time that the WAAS device keeps an idle connection open. The default is 75 seconds.
Keepalive Timeout	Length of time that the WAAS device keeps a connection open before disconnecting. The range is 1 to 120 seconds. The default is 90 seconds.
Enable Path MTU Discovery	Enables discovery of the largest IP packet size allowable between the various links along the forwarding path and automatically sets the correct value for the packet size. By default, this option is disabled. For more information, see Path MTU Discovery .

To configure TCP settings from the CLI, use the **tcp** global configuration command.

To enable the MTU discovery utility from the CLI, use the **ip path-mtu-discovery enable** global configuration command.

This section contains the following topics:

- [Explicit Congestion Notification](#)
- [Congestion Windows](#)
- [Retransmit Time Multiplier](#)
- [TCP Slow Start](#)
- [Path MTU Discovery](#)

Explicit Congestion Notification

The TCP Explicit Congestion Notification (ECN) feature allows an intermediate router to notify the end hosts of impending network congestion. It also provides enhanced support for TCP sessions associated with applications that are sensitive to delay or packet loss. The major issue with ECN is that the operation of both the routers and the TCP software stacks needs to be changed to accommodate the operation of ECN.

Congestion Windows

The congestion window (*cwnd*) is a TCP state variable that limits the amount of data that a TCP sender can transmit to the network before receiving an acknowledgment (ACK) from the receiving side of the TCP transmission. The TCP *cwnd* variable is implemented by the TCP congestion avoidance algorithm. The goal of the congestion avoidance algorithm is to continually modify the sending rate so that the sender automatically senses any increase or decrease in available network capacity during the entire data flow. When congestion occurs (manifested as packet loss), the sending rate is first lowered, and then gradually increased as the sender continues to probe the network for additional capacity.

Retransmit Time Multiplier

A TCP sender uses a timer to measure the time that has elapsed between sending a data segment and receiving the corresponding ACK from the receiving side of the TCP transmission. When this retransmit timer expires, the sender (according to the RFC standards for TCP congestion control) must reduce its sending rate. However, because the sender is not reducing its sending rate in response to network congestion, the sender is not able to make any valid assumptions about the current state of the network. Therefore, in order to avoid congesting the network with an inappropriately large burst of data, the sender implements the slow start algorithm, which reduces the sending rate to one segment per transmission. (See [TCP Slow Start](#).)

You can modify the sender's retransmit timer by using the Retransmit Time Multiplier field in the WAAS Central Manager. The retransmit time multiplier modifies the length of the retransmit timer by one to three times the base value, as determined by the TCP algorithm that is being used for congestion control.

**Note**

When making adjustments to the retransmit timer, be aware that they affect performance and efficiency. If the retransmit timer is triggered too early, the sender pushes duplicate data onto the network unnecessarily; if the timer is triggered too slowly, the sender remains idle for too long, unnecessarily slowing data flow.

TCP Slow Start

Slow start is one of four congestion-control algorithms used by TCP. The slow-start algorithm controls the amount of data being inserted into the network at the beginning of a TCP session when the capacity of the network is not known.

For example, if a TCP session began with an insertion of a large amount of data into the network, much of the initial burst of data is likely to be lost. Instead, TCP should initially transmit a modest amount of data, which has a high probability of successful transmission. Next, TCP can probe the network by sending increasing amounts of data as long as the network does not show signs of congestion.

The slow-start algorithm begins by sending packets at a rate that is determined by the congestion window, or *cwnd* variable. (See [Congestion Windows](#).) The algorithm continues to increase the sending rate until it reaches the limit set by the slow-start threshold (*ssthresh*) variable. Initially, the value of the *ssthresh* variable is adjusted to the receiver's maximum segment size (RMSS). However, when congestion occurs, the *ssthresh* variable is set to half the current value of the *cwnd* variable, marking the point of the onset of network congestion for future reference.

The starting value of the *cwnd* variable is set to that of the sender maximum segment size (SMSS), which is the size of the largest segment that a sender can transmit. The sender sends a single data segment, and because the congestion window is equal to the size of one segment, the congestion window is full. The sender then waits for the corresponding ACK from the receiving side of the transmission. When the ACK is received, the sender increases the congestion window size by increasing the value of the *cwnd* variable by the value of one SMSS. Now the sender can transmit two segments before the congestion window is again full and the sender is once more required to wait for the corresponding ACKs for these segments. The slow-start algorithm continues to increase the value of the *cwnd* variable, and thus increases the size of the congestion window by one SMSS for every ACK received. If the value of the *cwnd* variable increases beyond the value of the *ssthresh* variable, the TCP flow-control algorithm changes from the slow-start algorithm to the congestion-avoidance algorithm.

Path MTU Discovery

The WAAS software supports the IP Path Maximum Transmission Unit (MTU) Discovery method, as defined in RFC 1191. When enabled, the Path MTU Discovery feature discovers the largest IP packet size allowable between the various links along the forwarding path and automatically sets the correct value for the packet size. By using the largest MTU that the links can handle, the sending device can minimize the number of packets it must send.

IP Path MTU Discovery is useful when a link in a network goes down, which forces the use of another, different MTU-sized link. IP Path MTU Discovery is also useful when a connection is first being established, and the sender has no information about the intervening links.



Note

IP Path MTU Discovery is a process initiated by the sending device. If a server does not support IP Path MTU Discovery, the receiving device will have no available means to avoid fragmenting datagrams generated by the server.

By default, this feature is disabled. With the feature disabled, the sending device uses a packet size that is the lesser of 576 bytes and the next hop MTU. Existing connections are not affected when this feature is turned on or off.

Configuring a Static IP Route

The WAAS software allows you to configure a static route for a network or host. Any IP packet designated for the specified destination uses the configured route.

To configure a static IP route, follow these steps:

-
- Step 1** From the WAAS Central Manager menu, choose **Devices > device-name** (or **Device Groups > device-group-name**).
 - Step 2** Choose **Configure > Network > TCP/IP Settings > Static Routes**. The IP Route Entries window appears.
 - Step 3** In the taskbar, click the **Create New IP Route Entry** icon. The Creating New IP Route window appears.
 - Step 4** In the Destination Network Address field, enter the destination network IP address.
 - Step 5** In the Netmask field, enter the destination host netmask.
 - Step 6** In the Gateway's IP Address field, enter the IP address of the gateway interface.
The gateway interface IP address should be in the same network as that of one of the device's network interfaces.
 - Step 7** Alternately, if you select the check box for **IPv6 Address**, you need to specify the details only for the Destination Network Address and the Gateway's IP Address field.
 - Step 8** Click **OK**.
-

To configure a static route from the CLI, use the **ip route** global configuration command, or **IPv6 route** global configuration command.

Aggregating IP Routes

An individual WAE device can have IP routes defined and can belong to device groups that have other IP routes defined.

In the IP Route Entries window, the Aggregate Settings radio button controls how IP routes are aggregated for an individual device, as follows:

- Choose **Yes** to configure the device with all the IP routes that are defined for itself and for the device groups to which it belongs.
- Choose **No** to limit the device to just the IP routes that are defined for itself.

When you change the setting, you get the following confirmation message: **This option will take effect immediately and will affect the device configuration. Do you wish to continue?** Click **OK** to continue.

Configuring CDP Settings

The Cisco Discovery Protocol (CDP) is a device discovery protocol that runs on all Cisco-manufactured devices. With CDP, each device in a network sends periodic messages to all the other devices in the network. All the devices listen to periodic messages that are sent by others to learn about neighboring devices and determine the status of their interfaces.

With CDP, network management applications can learn the device type and the Simple Network Management Protocol (SNMP) agent address of neighboring devices. Applications are able to send SNMP queries within the network. CiscoWorks2000 also discovers the WAAS devices by using the CDP packets that are sent by the WAAS device after booting.

To perform device-related tasks, the WAAS device platform must support CDP to be able to notify the system manager of the existence, type, and version of the WAAS device platform.

To configure CDP settings, follow these steps:

-
- Step 1** From the WAAS Central Manager menu, choose **Devices > device-name** (or **Device Groups > device-group-name**).
 - Step 2** Choose **Configure > Network > CDP**. The CDP Settings window appears.
 - Step 3** Check the **Enable** check box to enable CDP support. By default, this option is enabled.
 - Step 4** In the Hold Time field, enter the time (in seconds) to specify the length of time that a receiver is to keep the CDP packets.
The range is 10 to 255 seconds. The default is 180 seconds.
 - Step 5** In the Packet Send Rate field, enter a value (in seconds) for the interval between CDP advertisements.
The range is 5 to 254 seconds. The default is 60 seconds.
 - Step 6** Click **Submit**.
-

To configure CDP settings from the CLI, use the **cdp** global configuration command.

Configuring the DNS Server

DNS allows the network to translate the domain names entered in requests into their associated IP addresses. To configure DNS on a WAAS device, you must complete the following tasks:

- Specify the list of DNS servers that are used by the network to translate requested domain names into IP addresses (both IPv4 and IPv6) that the WAAS device should use for domain name resolution.
- Enable DNS on the WAAS device.

To configure DNS server settings for a WAAS device, follow these steps:

-
- Step 1** From the WAAS Central Manager menu, choose **Devices** > *device-name* (or **Device Groups** > *device-group-name*).
 - Step 2** Choose **Configure** > **Network** > **DNS**. The DNS Settings window appears.
 - Step 3** In the Local Domain Name field, enter the name of the local domain. You can configure up to three local domain names. Separate items in the list with a space.
 - Step 4** In the List of DNS Servers field, enter a list of DNS servers used by the network to resolve hostnames to IP addresses.

You can configure up to three DNS servers. Separate items in the list with a space.

- Step 5** Click **Submit**.

A **Click Submit to Save** message appears in red next to the Current Settings line when there are pending changes to be saved after you have applied default and device group settings. To revert to the previously configured window settings, click **Reset**, which appears only when you have applied default or group settings to change the current device settings, but the settings have not yet been submitted.

To configure DNS name servers from the CLI, use the **ip name-server** global configuration command.

**Note**

On ISR-WAAS devices you cannot configure the DNS server from the Central Manager.

Configuring Windows Name Services

To configure Windows name services for a device or device group, follow these steps:

-
- Step 1** From the WAAS Central Manager menu, choose **Devices** > *device-name* (or **Device Groups** > *device-group-name*).
 - Step 2** Choose **Configure** > **Network** > **WINS**. The Windows Name Services Settings window appears.
 - Step 3** In the Workgroup or Domain Name field, enter the name of the workgroup (or domain) in which the chosen device or device group resides.

This name must be entered in shortname format and cannot exceed 15 characters. Valid characters include alphanumeric characters, a forward slash (/), an underscore (_), and a dash (-).

For example, if your domain name is cisco.com, the short name format is cisco.

- Step 4** Check the **NT** check box if the workgroup or domain is a Windows NT 4 domain. For example, if your domain name is cisco.com, the short name format is cisco. If your workgroup or domain is a Windows 2000 or Windows 2003 domain, do not check the NT check box. By default, this option is disabled.
- Step 5** In the WINS Server field, enter the hostname or IP address of the Windows Internet Naming Service (WINS) server.
- Step 6** Click **Submit**.
-

To configure Windows name services from the CLI, use the **windows-domain** global configuration command.

Configuring NAT Settings

When the WAAS Central Manager manages Azure devices, it is important to configure the NAT settings on the Central Manager because the Azure devices are in the public network and cannot communicate with the Central Manager using the internal ip address. The NAT settings can only be configured when the device is in the Central Manager mode, whether primary or secondary.

To configure NAT settings for a device, follow these steps:

-
- Step 1** From the WAAS Central Manager menu, choose **Devices** > *device-name*.
- Step 2** Choose **Configure** > **Network** > **NAT Settings**. The NAT Settings window appears.
- Step 3** In the **NAT IP** field, enter the external ip of the WAAS Central Manager and click on **Submit**. The external ip configuration (routed through NAT) is pushed to the Azure devices. This ip is used by the Azure devices to communicate with the Central Manager.
-



Configuring Administrative Login Authentication, Authorization, and Accounting

This chapter describes how to configure administrative login authentication, authorization, and accounting for Cisco Wide Area Application Services (WAAS) devices.

This chapter contains the following sections:

- [About Administrative Login Authentication and Authorization](#)
- [Configuring Administrative Login Authentication and Authorization](#)
- [Configuring AAA Command Authorization](#)
- [Configuring Cisco Prime Network Control System Single Sign-On](#)
- [Configuring AAA Accounting for WAAS Devices](#)
- [Viewing Audit Trail Logs](#)

Use the WAAS Central Manager GUI to centrally create and manage two different types of administrator user accounts (device-based CLI accounts and roles-based accounts) for your Cisco WAAS devices. For more information, see [Chapter 8, “Creating and Managing Administrator User Accounts and Groups.”](#)



Note

Throughout this chapter, the term Cisco WAAS device is used to refer collectively to the Cisco WAAS Central Managers and Cisco Wide Area Application Engines (WAEs) in your network. The term WAE refers to WAE appliances and WAE Network Modules (the Cisco WAAS NME-WAE family of devices) and Cisco SRE service modules (SM-SRE) running Cisco WAAS.

About Administrative Login Authentication and Authorization

In the WAAS network, administrative login authentication and authorization are used to control login requests from administrators who want to access a WAAS device for configuring, monitoring, or troubleshooting purposes.

Login authentication is the process by which WAAS devices verify whether an administrator who is attempting to log in to the device has a valid username and password. An administrator who is logging in must have a user account registered with the device. User account information serves to authorize a user for administrative login and configuration privileges. The user account information is stored in an authentication, authorization and accounting (AAA) database, and the WAAS devices must be configured to access the particular authentication server (or servers) where the AAA database is located. When a user attempts to log in to a device, the device compares the person’s username, password, and privilege level to the user account information that is stored in the database.

The WAAS software provides the following AAA support for users who have external access servers, for example, RADIUS or TACACS+ servers, and for users who require a local access database with AAA features:

- Authentication (or login authentication) is the action of determining who a user is. It checks the username and password.
- Authorization (or configuration) is the action of determining what a user is allowed to do. It permits or denies privileges for authenticated users in the network. Generally, authentication precedes authorization. Both authentication and authorization are required for a user login.
- Accounting is the action of keeping track of administrative user activities for system accounting purposes. In the WAAS software, AAA accounting through TACACS+ is supported. For more information, see [Configuring AAA Accounting for WAAS Devices](#).

**Note**

An administrator can log in to the WAAS Central Manager device through the console port or the WAAS Central Manager GUI. An administrator can also log in to a WAAS device that is functioning as a data center or branch WAE through the console port.

When the system administrator logs in to a WAAS device before authentication and authorization have been configured, the administrator can access the WAAS device by using the predefined superuser account (the predefined username is **admin** and the predefined password is **default**). When you log in to a WAAS device using this predefined superuser account, you are granted access to all the WAAS services and entities in the WAAS system.

**Note**

Each WAAS device must have one administrator account with the username **admin**. You cannot change the username of the predefined superuser account. The predefined superuser account must have the username **admin**.

All AAA interfaces, now support IPv6 configurations.

After you have initially configured your WAAS devices, we strongly recommend that you immediately change the password for the predefined superuser account (the predefined username is **admin**, the password is **default**, and the privilege level is superuser, privilege level 15) on each WAAS device.

For instructions on using the WAAS Central Manager GUI to change the password for a predefined superuser account, see [Changing the Password for Your Own Account](#) in Chapter 8, “Creating and Managing Administrative Groups.”

[Figure 7-1](#) shows how an administrator can log in to a WAE through the console port or the WAAS Central Manager GUIs. When the WAAS device receives an administrative login request, the WAE can check its local database or a remote third-party database (TACACS+, RADIUS, or Windows domain database) to verify the username with the password and to determine the access privileges of the administrator.

Figure 7-1 Authentication Databases and a WAE

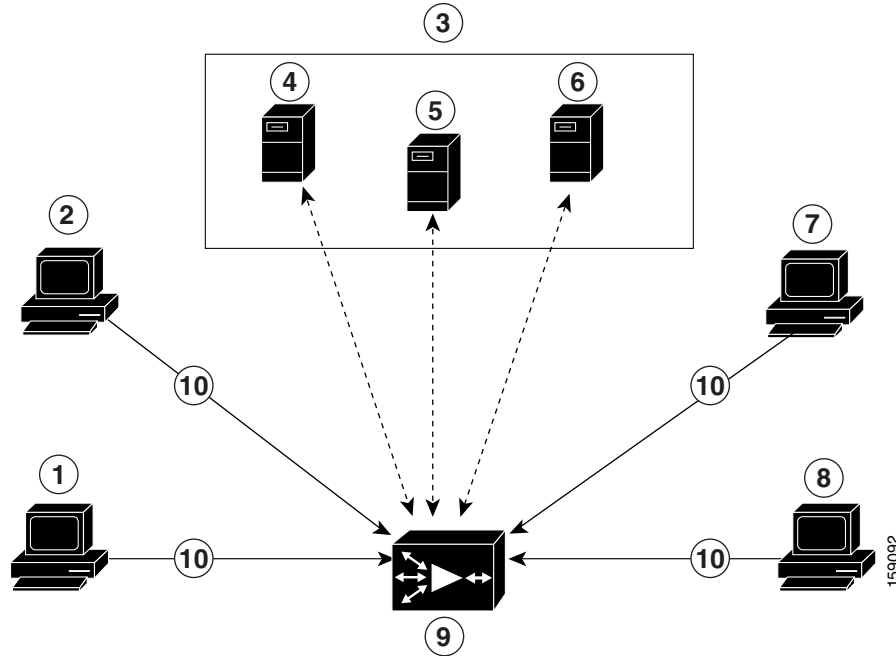

1	FTP/SFTP client	6	Windows domain server
2	WAAS Central Manager GUI	7	Console or Telnet clients
3	Third-party AAA servers	8	SSH client
4	RADIUS server	9	WAE that contains a local database and the default primary authentication database
5	TACACS+ server	10	Administrative login requests

The user account information is stored in an AAA database, and the WAAS devices must be configured to access the particular authentication server (or servers) that contains the AAA database. You can configure any combination of these authentication and authorization methods to control administrative login access to a WAAS device:

- Local authentication and authorization
- RADIUS
- TACACS+
- Windows domain authentication

**Note**

Even if you configure authentication using an external authentication server, you must create a role-based user or user group account in the WAAS Central Manager, as described in [Chapter 8, “Creating and Managing Administrator User Accounts and Groups.”](#)

For more information on the default AAA configuration, see [Default Administrative Login Authentication and Authorization Configuration](#). For more information on configuring AAA, see [Configuring Administrative Login Authentication and Authorization](#).

Default Administrative Login Authentication and Authorization Configuration

By default, a WAAS device uses the local database to obtain login authentication and authorization privileges for administrative users.

Table 7-1 lists the default configuration for administrative login authentication and authorization.

Table 7-1 *Default Configuration for Administrative Login Authentication and Authorization*

Feature	Default Value
Administrative login authentication	Enabled
Administrative configuration authorization	Enabled
Authentication server failover because the authentication server is unreachable	Disabled
TACACS+ port	Port 49
TACACS+ login authentication (console and Telnet)	Disabled
TACACS+ login authorization (console and Telnet)	Disabled
TACACS+ key	None specified
TACACS+ server timeout	5 seconds
TACACS+ retransmit attempts	2 times
RADIUS login authentication (console and Telnet)	Disabled
RADIUS login authorization (console and Telnet)	Disabled
RADIUS server IP address	None specified
RADIUS server UDP authorization port	Port 1645
RADIUS key	None specified
RADIUS server timeout	5 seconds
RADIUS retransmit attempts	2 times
Windows domain login authentication	Disabled
Windows domain login authorization	Disabled
Windows domain password server	None specified
Windows domain realm (Kerberos realm used for authentication when Kerberos authentication is used).	Null string
Note When Kerberos authentication is enabled, the default realm is DOMAIN.COM and security is the Active Directory Service (ADS).	
Hostname or IP address of the Windows Internet Naming Service (WIN) server for Windows domain	None specified
Window domain administrative group	There are no predefined administrative groups.
Windows domain NETBIOS name	None specified
Kerberos authentication	Disabled

Table 7-1 *Default Configuration for Administrative Login Authentication and Authorization (continued)*

Feature	Default Value
Kerberos server hostname or IP address (host that is running the Key Distribution Center (KDC) for the given Kerberos realm)	None specified
Kerberos server port number (port number on the KDC server)	Port 88
Kerberos local realm (default realm for WAAS)	kerberos-realm: null string
Kerberos realm (maps a hostname or DNS domain name to a Kerberos realm)	Null string

**Note**

If you configure a RADIUS or TACACS+ key on a WAAS device (the RADIUS and or TACACS+ client), make sure that you configure an identical key on the external RADIUS or TACACS+ server.

Change these defaults through the WAAS Central Manager GUI, as described in [Configuring Administrative Login Authentication and Authorization](#).

Multiple Windows domain utilities are included in the WAAS software to assist with Windows domain authentication configuration. You can access these utilities through the WAAS CLI by using the **windows-domain diagnostics EXEC** command.

Configuring Administrative Login Authentication and Authorization

To centrally configure administrative login authentication and authorization for a WAAS device or a device group (a group of WAEs), follow these steps:

-
- Step 1** Determine the login authentication scheme that you want to configure for the WAAS device to use when authenticating administrative login requests, for example, use the local database as the primary login database and your RADIUS server as the secondary authentication database.
- Step 2** Configure the login access control settings for the WAAS device, as described in [Configuring Login Access Control Settings for WAAS Devices](#).
- Step 3** Configure the administrative login authentication server settings on the WAAS device (if a remote authentication database is to be used). For example, specify the IP address(IPv4/IPv6) of the remote RADIUS servers, TACACS+ servers, or Windows domain server that the WAAS device should use to authenticate administrative login requests, as described in the following sections:
- [Configuring RADIUS Server Authentication Settings](#)
 - [About TACACS+ Server Authentication Settings](#)
 - [Configuring Windows Domain Server Authentication Settings](#)
- Step 4** Specify one or all of the following login authentication configuration schemes that the WAAS device should use to process administrative login requests:
- Specify the administrative login authentication scheme.
 - Specify the administrative login authorization scheme.

- (Optional) Specify the failover scheme for the administrative login authentication server.

For example, specify which authentication database the WAAS device should check to process an administrative login request. For more information, see [Enabling Administrative Login Authentication and Authorization Schemes for WAAS Devices](#).

**Caution**

Make sure that the RADIUS, TACACS+, or Windows domain authentication server is configured and operating correctly before disabling local authentication and authorization. If you disable local authentication, and RADIUS, TACACS+, or Windows domain settings are not configured correctly, or if the RADIUS, TACACS+, or Windows domain server is not online, you may be unable to log in to the WAAS device.

You can enable or disable the local and the remote databases (TACACS+, RADIUS, and Windows domain) through the WAAS Central Manager GUI or the WAAS CLI. The WAAS device verifies whether all the databases are disabled, and, if so, sets the system to the default state (see [Table 7-1](#)). If you have configured the WAAS device to use one or more of the external third-party databases (TACACS+, RADIUS, or Windows domain authentication) for administrative authentication and authorization, make sure that you have also enabled the local authentication and authorization method on the WAAS device, and that the local method is specified as the last option. Otherwise, the WAAS device will not go to the local authentication and authorization method by default if the specified external third-party databases are not reachable.

By default, local login authentication is enabled first. Local authentication and authorization uses locally configured login names and passwords to authenticate administrative login attempts. The login names and passwords are local to each WAAS device and are not mapped to individual usernames. When local authentication is disabled, if you disable all the other authentication methods, local authentication is re-enabled automatically.

You can disable local login authentication only after enabling one or more of the other administrative login authentication methods. However, when local login authentication is disabled, if you disable all other administrative login authentication methods, local login authentication is re-enabled automatically. You cannot specify different administrative login authentication methods for console and Telnet connections.

We strongly recommend that you set the administrative login authentication and authorization methods in the same order. For example, configure the WAAS device to use RADIUS as the primary login method, TACACS+ as the secondary login method, Windows as the tertiary method, and the local method as the quaternary method for both administrative login authentication and authorization.

**Note**

A TACACS+ server will not authorize a user who is authenticated by a different method. For example, if you configure Windows as the primary authentication method, but use TACACS+ as the primary authorization method, TACACS+ authorization will fail.

We strongly recommend that you specify the local method as the last method in your prioritized list of login authentication and authorization methods. By adhering to this practice, if the specified external third-party servers (TACACS+, RADIUS, or Windows domain servers) are not reachable, a WAAS administrator can still log in to a WAAS device through the local authentication and authorization method.

This section describes how to centrally configure administrative login authentication, and contains the following topics:

- [Configuring Login Access Control Settings for WAAS Devices](#)
- [Configuring Remote Authentication Server Settings for WAAS Devices](#)
- [Enabling Administrative Login Authentication and Authorization Schemes for WAAS Devices](#)

Configuring Login Access Control Settings for WAAS Devices

This section describes how to centrally configure remote login and access control settings for a WAAS device or device group, and contains the following topics:

- [Configuring Secure Shell Settings for WAAS Devices](#)
- [Disabling and Re-enabling the Telnet Service for WAAS Devices](#)
- [Configuring Message-of-the-Day Settings for WAAS Devices](#)
- [Configuring EXEC Timeout Settings for WAAS Devices](#)
- [Configuring Line Console Carrier Detection for WAAS Devices](#)

Configuring Secure Shell Settings for WAAS Devices

This section contains the following topics:

- [About SSH](#)
- [Operating Guidelines for SSH and WAAS Versions](#)
- [Procedure for Configuring SSH for WAAS Devices](#)

About SSH

Secure Shell (SSH) consists of a server and a client program. Like Telnet, you can use the client program to remotely log in to a machine that is running the SSH server, but unlike Telnet, messages transported between the client and the server are encrypted. The functionality of SSH includes user authentication, message encryption, and message authentication.

The SSH management window in the WAAS Central Manager GUI allows you to specify the key length, login grace time, and maximum number of password guesses allowed when logging in to a specific WAAS device or device group for configuration, monitoring, or troubleshooting purposes.

Operating Guidelines for SSH and WAAS Versions

Note these operational guidelines when enabling or disabling SSH for different WAAS versions:

Table 7-2 SSH Default Status and WAAS Versions

WAAS Version	SSH Default Value
6.2.3x and later	<ul style="list-style-type: none"> SSH is enabled by default. <p>To disable SSH, check the Disable check box on the SSH screen (displayed on the SSH Configuration window for WAAS versions 6.2.3x and later).</p> <ul style="list-style-type: none"> If you click Reset to remove features that you have enabled, after reset, the SSH feature will remain enabled by default. If you downgrade to a version earlier than 6.2.3x, the SSH default status will remain as enabled.
6.2.1x and earlier	<ul style="list-style-type: none"> SSH is disabled by default. <p>To enable SSH, check the Enable check box in the SSH screen (displayed on the SSH screen for WAAS versions earlier than 6.2.3x and shown in Figure 7-2).</p> <ul style="list-style-type: none"> If you click Reset to remove features that you have enabled, after reset, the SSH feature will remain disabled by default. If you upgrade to version 6.2.3x or later, the SSH default status will remain as disabled.

Procedure for Configuring SSH for WAAS Devices

To centrally enable the SSH feature on a WAAS device or a device group, follow these steps:

- Step 1** From the WAAS Central Manager menu, choose **Devices** > *device-name* (or **Device Groups** > *device-group-name*).
- Step 2** Choose **Configure** > **Network** > **Console Access** > **SSH**.
The SSH Configuration window appears. (See [Figure 7-2](#).)



Note The SSH Version 1 protocol is no longer supported. Only the SSH Version 2 protocol is supported by the WAAS device.

Figure 7-2 SSH Configuration Window

The screenshot shows the Cisco Wide Area Application Services (WAAS) configuration interface. The breadcrumb navigation is: Devices > vwaas180 > Configure > Network > Console Access > SSH. The 'Enable' checkbox is checked. Below it, there are three input fields: 'Login grace time' with a value of 300 and units of seconds (1-99999), 'Maximum number of password guesses' with a value of 3 and units of (1-3), and 'Length of Key' with a value of 1024 and units of bits (768-2048). At the bottom left, there are 'Submit' and 'Reset' buttons. At the bottom right, there is an 'Alarms' section showing 0 red, 3 yellow, and 0 green indicators.

Step 3 SSH enables login access to the chosen WAAS device (or the device group) through a secure and encrypted channel. The SSH default status is determined by your WAAS version (see [Table 7-2](#) for descriptions of these). Depending on your WAAS version, an **Enable** or **Disable** check box is displayed in the SSH Configuration window for you to change the default status, if needed.

You can also use the CLI to enable or disable SSH, using the **sshd enable** global configuration command, or the **no sshd enable** command.

Step 4 Check the **Allow non-admin users** check box to allow nonadministrative users to gain SSH access to the chosen device (or device group). By default, this option is disabled.



Note Nonadministrative users are nonsuperuser administrators. All nonsuperuser administrators have only restricted access to a WAAS device because their login accounts have a privilege level of 0. Superuser administrators have full access to a WAAS device because their login accounts have the highest level of privileges, a privilege level of 15.

Step 5 In the Login grace time field, specify the number of seconds for which an SSH session will be active during the negotiation (authentication) phase between the client and the server before it times out. The default is 300 seconds.

Step 6 In the Maximum number of password guesses field, specify the maximum number of incorrect password guesses allowed per connection. The default is 3.

Although the value in the Maximum number of password guesses field specifies the number of password guesses allowed from the SSH server side, the actual number of password guesses for an SSH login session is determined by the combined number of allowed password guesses of the SSH server and the SSH client. Some SSH clients limit the maximum number of allowed password guesses to three (or to one in some cases), even though the SSH server allows more than this number of guesses. When you specify n password guesses allowed, certain SSH clients interpret this number as $n + 1$. For example, when configuring the number of guesses to two for a particular device, SSH sessions from some SSH clients will allow three password guesses.

Step 7 In the Length of key field, specify the number of bits required to create an SSH key. The default is 1024.

When you enable SSH, be sure to generate both a private and a public host key, which client programs can use to verify the server's identity. When you use an SSH client and log in to a WAAS device, the public key for the SSH daemon running on the device is recorded in the client machine `known_hosts` file in your home directory. If the WAAS administrator subsequently regenerates the host key by specifying the number of bits in the Length of key field, you must delete the old public key entry associated with the WAAS device in the `known_hosts` file before running the SSH client program to log in to the WAAS device. When you use the SSH client program after deleting the old entry, the `known_hosts` file is updated with the new SSH public key for the WAAS device.

Step 8 Click **Submit** to save the settings.

A **Click Submit to Save** message appears in red in the Current Settings line when there are pending changes to be saved after you have applied the default or device group settings. You can also revert to the previously configured settings by clicking **Reset** button, which is visible only if you have applied default or group settings to change the current device settings, but have not yet submitted the changes.

If you try to exit this window without saving the modified settings, a warning dialog box prompts you to submit the changes. This dialog box appears only if you are using the Internet Explorer browser.

To configure SSH settings from the CLI, you can use the **sshd** and **ssh-key-generate** global configuration commands.

Disabling and Re-enabling the Telnet Service for WAAS Devices

By default, the Telnet service is enabled on a WAAS device. You must use a console connection instead of a Telnet session to define device network settings on a WAAS device. However, after you have used a console connection to define the device network settings, you can use a Telnet session to perform subsequent configuration tasks.

You must enable the Telnet service before you can use the Telnet button in the Device Dashboard window to use Telnet to connect to a device.



Note

Telnet is not supported in Internet Explorer. If you want to use the Telnet button from the Device Dashboard, use a different web browser.

To centrally disable the Telnet service on a WAAS device or a device group, follow these steps:

-
- Step 1** From the WAAS Central Manager menu, choose **Devices** > *device-name* (or **Device Groups** > *device-group-name*).
 - Step 2** Choose **Configure** > **Network** > **Console Access** > **Telnet**.
The Telnet Settings window appears.
 - Step 3** Uncheck the **Telnet Enable** check box to disable the terminal emulation protocol for remote terminal connection for the chosen device (or device group).
 - Step 4** Click **Submit** to save the settings.
A **click submit to save** message appears in red next to the Current Settings line when there are pending changes to be saved after you have applied default or device group settings. You can also revert to the previously configured settings by clicking **Reset**, which is visible only if you have applied default or group settings to change the current device settings, but have not yet submitted the changes.
If you try to exit this window without saving the modified settings, a warning dialog box prompts you to submit the changes. This dialog box appears only if you are using the Internet Explorer browser.
-

To centrally re-enable the Telnet service on the device (or device group) at a later time, check the **Telnet Enable** check box in the Telnet Settings window, and click **Submit**.

From the CLI, use the **no telnet enable** global configuration command to disable Telnet, or the **telnet enable** global configuration command to enable it.

Configuring Message-of-the-Day Settings for WAAS Devices

The Message of the Day (MOTD) feature enables you to provide information bits to the users when they log in to a device that is a part of your WAAS network. There are three types of messages that you can set up:

- MOTD banner
- EXEC process creation banner
- Login banner

To configure the MOTD settings, follow these steps:

-
- Step 1** From the WAAS Central Manager menu, choose **Devices** > *device-name*.

- Step 2** Choose **Configure > Network > Console Access > Message of the day**.
The MOTD Configuration window for the chosen device appears.
- Step 3** To enable the MOTD settings, check the **Enable** check box.
The Message of the Day (MOTD) banner, EXEC process creation banner, and Login banner fields become enabled.
- Step 4** In the Message of the Day (MOTD) Banner field, enter a string that you want displayed as the MOTD banner after a user logs in to the device.

In the Message of the Day (MOTD) Banner, EXEC Process Creation Banner, and Login Banner fields, you can enter a maximum of 1024 characters. A new line character (or Enter) is counted as two characters, as it is interpreted as \n by the system. You cannot use special characters such as ` , % , ^ , and " in the MOTD text. If your text contains any of these special characters, WAAS software removes it from the MOTD output.
- Step 5** In the EXEC Process Creation Banner field, enter a string to be displayed as the EXEC process creation banner when a user enters into the EXEC shell of the device.
- Step 6** In the Login Banner field, enter a string to be displayed after the MOTD banner, when a user attempts to log in to the device.
- Step 7** To save the configuration, click **Submit**.
-

Configuring EXEC Timeout Settings for WAAS Devices

To centrally configure the length of time for which an inactive Telnet session remains open on a WAAS device or device group, follow these steps:

- Step 1** From the WAAS Central Manager menu, choose **Devices > device-name** (or **Device Groups > device-group-name**).
- Step 2** Click the **Edit** icon next to the device (or device group) for which you want to configure the EXEC timeout.
- Step 3** Choose **Configure > Network > Console Access > Exec Timeout**.
- Step 4** In the Exec Timeout field, specify the number of minutes after which an active session times out. The default is 15 minutes.

A Telnet session with a WAAS device can remain open and inactive for the period specified in this field. When the EXEC timeout period elapses, the WAAS device automatically closes the Telnet session.
- Step 5** Click **Submit** to save the settings.

A **click submit to save** message appears in red next to the Current Settings line when there are pending changes to be saved after you have applied default or device group settings. You can also revert to the previously configured settings by clicking **Reset**, which is visible only if you have applied default or group settings to change the current device settings, but have not yet submitted the changes.

If you try to exit this window without saving the modified settings, a warning dialog box prompts you to submit the changes. This dialog box appears only if you are using the Internet Explorer browser.
-

To configure the Telnet session timeout from the CLI, use the **exec-timeout** global configuration command.

Configuring Line Console Carrier Detection for WAAS Devices

You should enable carrier detection if you plan to connect the WAAS device to a modem for receiving calls.

**Note**

By default, this feature is disabled on a WAAS device.

To centrally enable Console Line Carrier Detection for a WAAS device or device group, follow these steps:

-
- Step 1** From the WAAS Central Manager menu, choose **Devices** > *device-name* (or **Device Groups** > *device-group-name*).
 - Step 2** Choose **Configure** > **Network** > **Console Access** > **Console Carrier Detect**.
The Console Carrier Detect Settings window appears.
 - Step 3** Check the **Enable console line carrier detection before writing to the console** check box to enable the window for configuration.
 - Step 4** Click **Submit** to save the settings.
A message appears that explains that if a null-modem cable that does not have a carrier detect pin wired is being used, the WAE may appear unresponsive on the console until the carrier detect signal is asserted. To recover from a misconfiguration, the WAE should be rebooted and the 0x2000 bootflag should be set to ignore the carrier detect setting.
 - Step 5** Click **OK** to continue.
-

To configure console line carrier detection from the CLI, you can use the **line console carrier-detect** global configuration command.

Configuring Remote Authentication Server Settings for WAAS Devices

If you have determined that your login authentication scheme should include one or more external authentication servers, you must configure these server settings before you can configure the authentication scheme in the WAAS Central Manager GUI. The section contains the following topics:

- [Configuring RADIUS Server Authentication Settings](#)
- [About TACACS+ Server Authentication Settings](#)
- [Configuring TACACS+ Server Settings](#)
- [Configuring Windows Domain Server Authentication Settings](#)
- [LDAP Server Signing](#)

Configuring RADIUS Server Authentication Settings

RADIUS is a client/server authentication and authorization-access protocol used by a network access server (NAS) to authenticate users attempting to connect to a network device. The NAS functions as a client, passing user information to one or more RADIUS servers. The NAS permits or denies network access to a user based on the response that it receives from one or more RADIUS servers. RADIUS uses the User Datagram Protocol (UDP) for transport between the RADIUS client and server.

RADIUS authentication clients reside on devices that are running WAAS software. When enabled, these clients send authentication requests to a central RADIUS server, which contains user authentication and network service access information.

You can configure a RADIUS key on the client and server. If you configure a key on the client, it must be the same as the one configured on the RADIUS servers. The RADIUS clients and servers use the key to encrypt all the RADIUS packets transmitted. If you do not configure a RADIUS key, packets are not encrypted. The key itself is never transmitted over the network.

**Note**

For more information about how the RADIUS protocol operates, see RFC 2138, *Remote Authentication Dial In User Service (RADIUS)*.

RADIUS authentication usually occurs when an administrator first logs in to the WAAS device to configure the device for monitoring, configuration, or troubleshooting purposes. RADIUS authentication is disabled by default. You can enable RADIUS authentication and other authentication methods at the same time. You can also specify which method to use first.

You can configure multiple RADIUS servers; authentication is attempted on the servers in order. If the first server is unreachable, then authentication is attempted on the other servers in the farm, in order. If authentication fails for any reason other than a server being unreachable, authentication is not attempted on the other servers in the farm.

**Tip**

The WAAS Central Manager does not cache user authentication information. Therefore, the user is reauthenticated against the RADIUS server for every request. To prevent performance degradation caused by many authentication requests, install the WAAS Central Manager device in the same location as the RADIUS server, or as close as possible to it, to ensure that authentication requests can occur as quickly as possible.

To centrally configure RADIUS server settings for a WAAS device or device group, follow these steps:

- Step 1** From the WAAS Central Manager menu, choose **Devices** > *device-name* (or **Device Groups** > *device-group-name*).
- Step 2** Choose **Configure** > **Security** > **AAA** > **RADIUS**.
The RADIUS Server Settings window appears. (See [Figure 7-3](#).)

Figure 7-3 RADIUS Server Settings Window

RADIUS Server Settings for WAE, wae-r35-7371-3

Current settings: None (Using Factory Defaults)

Time to Wait: 5 (seconds) (1-20)

Number of Retransmits: 2

Shared Encryption Key:

Server 1 Name: Server 1 Port: 1645

Server 2 Name: Server 2 Port:

Server 3 Name: Server 3 Port:

Server 4 Name: Server 4 Port:

Server 5 Name: Server 5 Port:

* To use RADIUS for Login or Configuration Authentication, please go to the Authentication Methods page.

Note: * - Required Field

Submit Cancel

- Step 3** In the Time to Wait field, specify how long the device or device group should wait for a response from the RADIUS server before timing out. The range is from 1 to 20 seconds. The default value is 5 seconds.
- Step 4** In the Number of Retransmits field, specify the number of attempts allowed to connect to a RADIUS server. The default value is 2 times.
- Step 5** In the Shared Encryption Key field, enter the secret key that is used to communicate with the RADIUS server.



Note If you configure a RADIUS key on the WAAS device (the RADIUS client), make sure that you configure an identical key on the external RADIUS server. Do not use the following characters: space, backwards single quote (‘), double quote (”), pipe (|), or question mark (?).

- Step 6** In the Server Name field, enter an IP address (IPv4/IPv6) or hostname of the RADIUS server. Five different hosts are allowed.
- Step 7** In the Server Port field, enter a UDP port number on which the RADIUS server is listening. You must specify at least one port. Five different ports are allowed.
- Step 8** Click **Submit** to save the settings.

You can now enable RADIUS as an administrative login authentication and authorization method for this WAAS device or device group, as described in [Enabling Administrative Login Authentication and Authorization Schemes for WAAS Devices](#).

To configure RADIUS settings from the CLI, you can use the **radius-server** global configuration command.

About TACACS+ Server Authentication Settings

TACACS+ controls access to network devices by exchanging network access server (NAS) information between a network device and a centralized database to determine the identity of a user or an entity. TACACS+ is an enhanced version of TACACS, a UDP-based access-control protocol specified by RFC 1492. TACACS+ uses TCP to ensure reliable delivery and encrypt all the traffic between the TACACS+ server and the TACACS+ daemon on a network device.

TACACS+ works with many authentication types, including fixed password, one-time password, and challenge-response authentication. TACACS+ authentication usually occurs when an administrator first logs in to the WAAS device to configure the WAE for monitoring, configuring, or troubleshooting.

When a user requests restricted services, TACACS+ encrypts the user password information using the MD5 encryption algorithm and adds a TACACS+ packet header. This header information identifies the packet type being sent, for example, an authentication packet, the packet sequence number, the encryption type used, and the total packet length. The TACACS+ protocol then forwards the packet to the TACACS+ server.

A TACACS+ server can provide authentication, authorization, and accounting functions. These services, while all part of TACACS+, are independent of one another. Therefore a given TACACS+ configuration can use any or all of the three services.

When the TACACS+ server receives a packet, it does the following:

- Authenticates the user information and notifies the client that the login authentication has either succeeded or failed.
- Notifies the client that authentication will continue and that the client must provide additional information. This challenge-response process can continue through multiple iterations until login authentication either succeeds or fails.

You can configure a TACACS+ key on the client and server. If you configure a key on a WAAS device, it must be the same as the one configured on the TACACS+ servers. The TACACS+ clients and servers use the key to encrypt all the TACACS+ packets transmitted. If you do not configure a TACACS+ key, packets are not encrypted.

TACACS+ authentication is disabled by default. You can enable TACACS+ authentication and local authentication at the same time.

You can configure one primary and two backup TACACS+ servers; authentication is attempted on the primary server first. If the primary server is unreachable, authentication is attempted on the other servers in the farm, in order. If authentication fails for any reason other than a server being unreachable, authentication is not attempted on the other servers in the farm.

The TACACS+ database validates users before they gain access to a WAAS device. TACACS+ is derived from the United States Department of Defense (RFC 1492) and is used by Cisco Systems as an additional control of nonprivileged and privileged mode access. The WAAS software supports TACACS+ only and not TACACS or Extended TACACS.

If you are using TACACS+ for user authentication, you can create WAAS user group names that match the user groups that you have defined on the TACACS+ server. WAAS can then dynamically assign roles and domains to users based on their membership in the groups defined on the TACACS+ server. (See [Working with Accounts](#) in Chapter 8, “Creating and Managing Administrative Groups.”) You must specify associated group names for each user in the TACACS+ configuration file, as follows:

```
user = tacusr1 {
  default service = permit
  service = exec
  {
    waas_rbac_groups = admin,groupname1,groupname2
  }
  priv-lvl = 15
}
```

```

}
global = cleartext "tac"
}

```

For each user, list the groups they belong to in the `waas_rbac_groups` attribute, separating each group from the next with a comma.

The dynamic assignment of roles and domains based on external user groups requires a TACACS+ server that supports shell custom attributes. For example, these are supported in Cisco ACS 4.x and 5.1 and later.

**Tip**

The WAAS Central Manager does not cache user authentication information. Therefore a user is reauthenticated against the TACACS+ server for every request. To prevent performance degradation caused by many authentication requests, install the WAAS Central Manager device in the same location as the TACACS+ server, or as close as possible to it, to ensure that authentication requests can occur as quickly as possible.

Configuring TACACS+ Server Settings

The WAAS software CLI EXEC mode allows you to set, view, and test system operations. The mode is divided into two access levels: user and privileged. To access privileged-level EXEC mode, enter the **enable** EXEC command at the user access-level prompt and specify the admin password when prompted for a password.

In TACACS+, the enable password feature allows an administrator to define a different enable password per administrative-level user. If an administrative-level user logs in to the WAAS device with a normal-level user account (privilege level of 0) instead of an admin or admin-equivalent user account (privilege level of 15), that user must enter the admin password to access privileged EXEC mode.

```

WAE> enable
Password:

```

**Note**

This caveat applies even if the WAAS users are using TACACS+ for login authentication.

To centrally configure TACACS+ server settings on a WAAS device or device group, follow these steps:

Step 1 From the WAAS Central Manager menu, choose **Devices > device-name** (or **Device Groups > device-group-name**).

Step 2 Choose **Configure > Security > AAA > TACACS+**.

The TACACS+ Server Settings window appears.

**Note**

The TACACS+ server configuration cannot be modified or deleted when AAA Command Authorization is enabled.

Step 3 Check the **Use ASCII Password Authentication** check box to use the ASCII password type for authentication.

The default password type is PAP (Password Authentication Protocol). However, you can change the password type to ASCII when the authentication packets are to be sent in ASCII cleartext format.

- Step 4** In the Time to Wait field, specify how long the device should wait before timing out. The range is from 1 to 20 seconds. The default value is 5 seconds.
- Step 5** In the Number of Retransmits field, specify the number of attempts allowed to connect to a TACACS+ server. The range is 1 to 3 times. The default value is 2 times.
- Step 6** In the Security Word field enter the secret key that is used to communicate with the TACACS+ server. The secret key value can contain a maximum of 32 alphanumeric characters. The following characters are not allowed: space, backwards single quote (`), double quote ("), pipe (|), number sign (#), question mark (?), or backslash (\).

**Note**

- The Security Word field is a mandatory field.
- When you configure a TACACS+ key on the WAAS device (the TACACS+ client), you must also configure an identical key on the external TACACS+ server.

- Step 7** In the Primary Server field, enter an IP address (IPv4/IPv6) or hostname for the primary TACACS+ server.
To change the default port (49), enter the port in the Primary Server Port field.
- Step 8** In the Secondary Server field, enter an IP address (IPv4/IPv6) or hostname for a secondary TACACS+ server.
To change the default port (49), enter the port in the Secondary Server Port field.
- Step 9** In the Tertiary Server field, enter an IP address (IPv4/IPv6) or hostname for a tertiary TACACS+ server.
To change the default port (49), enter the port in the Tertiary Server Port field.

**Note**

You can specify up to two backup TACACS+ servers.

- Step 10** Click **Submit** to save the settings.

You can now enable TACACS+ as an administrative login authentication and authorization method for this WAAS device or device group, as described in [Enabling Administrative Login Authentication and Authorization Schemes for WAAS Devices](#).

To configure TACACS+ settings from the CLI, use the **tacacs** global configuration command.

Configuring Windows Domain Server Authentication Settings

A Windows domain controller can be configured to control access to the WAAS software services using either a challenge/response or shared secret authentication method. The system administrator can log in to the WAAS device by using an FTP, SSH, or Telnet session, the console, or the WAAS Central Manager GUI with a single user account (username/password/privilege). RADIUS and TACACS+ authentication schemes can be configured simultaneously with Windows domain authentication. Logging of a variety of authentication login statistics can be configured when Windows domain authentication is enabled. The log files and the statistical counters and related information can be cleared at any time.

In a WAAS network, Windows domain authentication is used in the following scenarios:

- Logging in to the WAAS Central Manager GUI
- CLI configuration on any WAAS device

You can configure Windows authentication for the WAAS Central Manager device, a single WAAS device, or a group of devices. To configure Windows domain authentication on a WAAS device, configure a set of Windows domain authentication settings.

**Note**

Windows domain authentication is not performed unless a Windows domain server is configured on the WAAS device. If the device is not successfully registered, authentication and authorization do not occur. WAAS supports authentication by a Windows domain controller running only on Windows Server 2000, Windows Server 2003, or Windows Server 2008.

This section contains the following topics:

- [Configuring Windows Domain Server Settings on a WAAS Device](#)
- [Unregistering a WAE from a Windows Domain Controller](#)

Configuring Windows Domain Server Settings on a WAAS Device

You should know the name and IP address, or hostname, of the Windows domain controller that will be used for authentication.

**Note**

If the Central Manager is Version 4.2.3a or later, and you want to configure the Windows domain settings on a WAAS device that is running Version 4.2.3 or 4.2.1, you cannot use the Windows Domain Server Settings page on the Central Manager. You must use the **windows-domain diagnostics net** CLI command, as described in this procedure.

To configure Windows Domain server settings on a WAAS device or device group, follow these steps:

Step 1 From the WAAS Central Manager menu, choose **Devices** > *device-name* (or **Device Groups** > *device-group-name*).

Step 2 Choose **Configure** > **Security** > **AAA** > **Windows User Authentication**.

The Windows User Authentication window appears. (See [Figure 7-4](#).)

**Note**

Workgroup settings are only required for Windows domain authentication, not for a domain join. You can skip to workgroup settings if you are only performing a domain join.

Figure 7-4 Windows User Authentication

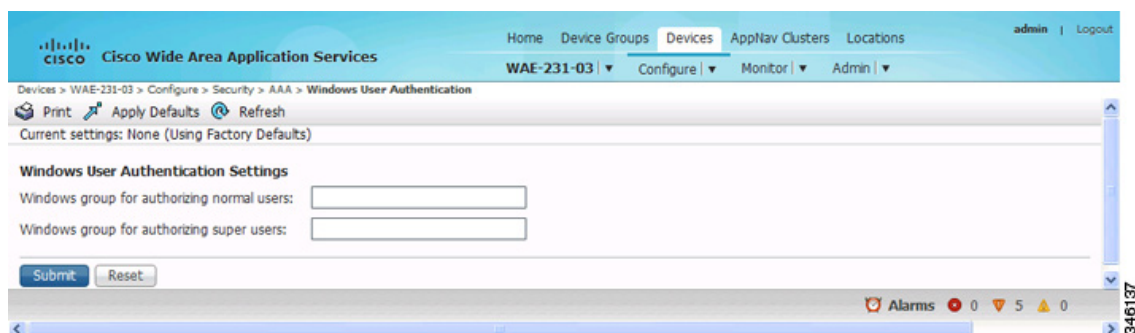

- Step 3** In the Windows group for authorizing normal users field, specify an administrative group for normal users (nonsuperuser administrators), who only have restricted access to the chosen device (or device group) because their administrator user account has a privilege level of 0.



Note By default, there are no predefined user groups for Windows domain authorization configured on a WAE.

- Step 4** In the Windows group for authorizing super users field, specify an administrative group for superusers (superuser administrators), who have unrestricted access to the chosen device (or device group) because their administrator user account has a privilege level of 15.



Note In addition to configuring Windows domain administrative group on a WAE, you must configure the Windows domain administrative group on your Microsoft Windows 2000, 2003, or 2008 server. You must create a Windows Domain administrative superuser group and a normal user group. Make sure that the group scope for the superuser group is set to global, assign user member to newly created administrative group, and add the user account, for example, the winsuper user, to the Windows domain superuser group. For more information about how to configure the Windows domain administrative group on your Windows server, see the corresponding Microsoft documentation.

When a user attempts to access this WAE through a Telnet session, FTP, or SSH session, the WAE is configured to use the Active Directory user database to authenticate a request for administrative access.

- Step 5** From the WAAS Central Manager menu, choose **Devices** > *device-name* (or **Device Groups** > *device-group-name*).

- Step 6** Choose **Configure** > **Security** > **Windows Domain** > **Domain Settings**.

The Domain Settings window appears. (See [Figure 7-5](#).)

Figure 7-5 Domain Settings

The screenshot displays the 'Domain Settings' configuration page in the Cisco WAAS Central Manager. The breadcrumb trail is: Home > Device Groups > Devices > WAE-231-03 > Configure > Security > Windows Domain > Domain Settings. The page shows 'Mandatory Settings for Domain Join' with the following details:

- Currently Configured DNS Settings: Domain Name: cisco.com, DNS Server: 171.68.10.70
- Currently Configured NTP Settings: NTP Server: 171.68.10.150 171.68.10.80

The configuration form includes:

- Domain Name: (with a 'Create New...' link)
- User Names:
- Password:
- Confirm Password:

Buttons for 'Join' and 'Leave' are present. Below the form is a 'Domain Join Status' table:

Device Name	Device IP	Domain Name	Join Status	Join Time	Remarks
WAE-231-03	2.43.65.52		No Registration Record found.		Please join the WAE

At the bottom, there are two informational links:

- To configure domain identity for Encrypted MAPI Acceleration, please navigate to [Encrypted Services](#)
- To configure windows user authentication, please navigate to [Authentication Methods and Windows User Authentication](#)

**Note**

In WAAS versions earlier than 5.1.1, if the related WINS server and the workgroup or domain name have not been defined for the chosen device (or device group), an informational message is displayed at the top of this window to inform you that these related settings are currently not defined, as shown in [Figure 7-5](#). To define these settings, choose **Configure > Network > WINS**.

Domain name, DNS server, and NTP configuration are mandatory prerequisites for the Windows domain join. The Windows domain controller and the WAAS device must be in time sync for Kerberos authentication to succeed. For full AAA functionality, workgroup and WINS server must also be configured.

In WAAS versions earlier than 5.1.1, NetBIOS name does not have to be configured for Windows domain join. If left unconfigured, the first 15 characters of the hostname are automatically assigned as the NetBIOS name during the join. For WAAS versions later than 5.1.1, NetBIOS name, WINS server, and workgroup configuration settings are not required for Windows domain authentication configuration.

Step 7 From the Domain Name drop-down list, choose a name or click **Create New** to create a new Local Domain Name.

Step 8 If your WAAS device (or device group) is a previous version of the software.

- a. Choose **Kerberos, NTLM1** plus ESS (Extended Session Security), or **NTLM2** as a shared secure authentication method for administrative logins to the chosen device (or device group). The default authentication protocol is kerberos.

**Note**

In WAAS version 5.0.1 onwards, Windows domain user login authentication using NTLM protocol is deprecated. We recommend that you use Kerberos protocol for Windows domain user login authentication.

In WAAS Version 5.1.1 onwards, Windows domain user authentication using NTLM protocol is not supported.

You can use the Kerberos protocol, NTLMv1 plus ESS (Extended Session Security), or NTLMv2 for encrypted MAPI acceleration.

Click **Auto Detect The Parameters** when using Kerberos to automatically obtain the kerberos realm, kerberos server, and domain controller. Domain, DNS, and NTP parameters must be configured first. This option is not supported with NTLM.

After the device is queried for the parameters, a status message is displayed on the screen indicating either success or failure. The process may not be immediate and the status message will not appear until the auto detection process is completed.

When successful, the parameters can be reviewed and edited, if required. After the parameters are reviewed, the values can be submitted.

If auto detection fails, check the configured domain/DNS configuration and enter them manually. The values can then be submitted.



Note Kerberos Version 5 is used for Windows systems running Windows 2000 or later, with users logging in to domain accounts.

For Windows domain join using Kerberos authentication, you must have the following ports open on the firewall for outgoing traffic: 53 UDP/TCP, 88 UDP/TCP, 123 UDP, 135 TCP, 137 UDP, 139 TCP, 389 UDP/TCP, 445 TCP, 464 UDP/TCP, and 3268 TCP.

- b. (Skip this step for Kerberos) For NTLM, choose **version 1** or **version 2** from the drop-down list. NTLM Version 1 is selected by default.



Note For WAAS v5.3.1, NTLM is also supported for encrypted MAPI (EMAPI). Note the following about NTLM for EMAPI:

NTLM for EMAPI does not require any additional configuration other than what is required for Kerberos. However, the client must be joined to the domain.

NTLM with EMAPI uses a key for each NTLM user. These keys are stored in memory and removed after a reload. If, for example, a core WAE is rebooted during the night, all NTLM keys need to be gathered again at startup, which may cause an increase in latency in establishing the client-server connection.

- NTLM Version 1 is used for all Windows systems, including legacy systems such as Windows 98 with Active Directory, Windows NT, and more recent Windows systems, such as Windows 2000, Windows XP, and Windows 2003. We recommend the use of Kerberos if you are using a Windows 2000 SP4 or Windows 2003 domain controller.
- NTLM Version 2 is used for Windows systems running Windows 98 with Active Directory, Windows NT 4.0 (Service Pack 4 or later), Windows XP, Windows 2000, and Windows 2003. Enabling NTLM Version 2 support on the WAAS print server will not allow access to clients who use NTLM or LM.



Caution Enable NTLM Version 2 support in the print server only if all the clients' security policy has been set to Send NTLMv2 responses only/Refuse LM and NTLM.

- c. (Skip this step for NTLM) In the Kerberos Realm field, enter the fully qualified name of the realm in which the WAAS device resides. In the Key Distribution center, enter the fully qualified name or the IP address of the distribution center for the Kerberos key. If you clicked **Auto Detect The Parameters** when you selected the Kerberos authentication method, these fields will already be populated.

All Windows 2000 domains are also Kerberos realms. Because the Windows 2000 domain name is also a DNS domain name, the Kerberos realm name for the Windows 2000 domain name is always in uppercase letters. This capitalization follows the recommendation for using DNS names as realm names in the Kerberos Version 5 protocol document (RFC-4120) and affects only interoperability with other Kerberos-based environments.

- d. In the Domain Controller field, enter the name of the Windows Domain Controller.

When you click **Submit**, the Central Manager validates this name by requesting the WAAS device (if Version 4.2.x or later) to resolve the domain controller name. If the domain controller is not resolvable, you are asked to submit a valid name. If the device is offline, you are asked to verify

device connectivity. If you are configuring a device group, the domain controller name is not validated on each device before this page is accepted and if it is not resolvable on a device, the configuration changes on this page are not applied to that device.

- e. Click **Submit**.



Note Make sure that you click **Submit** now so that the specified changes are committed to the WAAS Central Manager database. The Domain Administrator's username and password, which you will enter in [Step 9](#), are not stored in the WAAS Central Manager's database.

Step 9 Register the chosen device (or device group) with the Windows Domain Controller as follows:

- a. In the User Name field, enter a username (the domain\username or the domain name plus the username) for the specified Windows Domain Controller. This must be the username and password of a user who has administrative privileges in Active Directory (permission to add a computer to a domain).

If your WAAS device (or device group) is running a previous version of the software, click the **Domain Join** tab.

For NTLM, the user credentials can be that of any normal user belonging to the Domain Users group. For Kerberos, it is preferable that the user credentials belong to the Domain Administrators group, but need not be the system default Administrator user.

By default, a Windows Domain Administrator user is part of following groups - Administrators, Domain Administrators, Domain Users, Enterprise Administrators, Group policy creator owners and Schema Administrators.

However, only Administrators and Domain/Enterprise Administrators have the privileges to join a device to the Windows Active Directory.

If users do not want to use the administrative privileges, they can be a part of the default group called Account Operators, which has the privilege to join the device to a Windows Active Directory (AD). However, since the Account Operators group has wide access to the AD, we recommend to use AD Delegation to grant permissions using ACLs as described below.

- 1) Go to Active Directory Users and Computers and select **Computers>Action>Delegate Control** to open the **Delegate Control Wizard**. Select **Users and Groups>Create custom task to Delegate**.
- 2) Verify that the user/group is added to the AD. Click **Computers>Properties>Security** and view if the user/group is added.
- 3) Select **Advanced** and add ACL for **Create and Delete Computer Objects** by selecting the check-boxes.

To join the Windows domain successfully, the Windows domain user should either be a part of the **Account Operators** group or should have been granted permission to join the domain through AD delegation.



Note To use Windows domain server authentication, the WAAS device must join the Windows domain. For registration, you will require a user credential with permission to join a machine to the Windows domain. The user credential used for registration is not shown in clear text anywhere, including log files. WAAS does not modify the structure or schema of the Windows Active Directory.



Note A domain join is required for encrypted MAPI acceleration using a machine account.

- b. In the Password field, enter the password of the specified Windows Domain Controller account.
- c. In the Confirm password field, re-enter the password of the specified Windows Domain Controller.
- d. (Optional, if your WAAS device [or device group] is running a previous version of the software) If necessary, enter the name of the organizational unit in the Organizational Unit field (for Kerberos authentication only).
- e. Click **Join**.



Note When you click **Join**, WAAS Central Manager immediately sends a registration request to the WAAS device (or all of the devices in the device group) using SSH (the specified domain administrator password is encrypted by SSH). The registration request instructs the device to perform domain registration with the specified Windows Domain Controller using the specified domain username and password. If the device is accessible (if it is behind a NAT and has an external IP address), the registration request is performed by the device (or device group).

The status of the registration request is shown in the Domain Join Status table.

- f. If your WAAS device (or device group) is running a version of the software that is earlier than latest version of WAAS, click the **Show Join Status** button to view the status of the registration request. It may take a few moments for the results to be updated. If the join request fails, the result is shown in the Domain Join Status table.
 - g. Wait for a few more minutes and try again to see the updated authentication status. If the request succeeds, the domain registration status is shown in the Domain Join Status table.
-

After configuring the Windows domain settings, to complete the process of enabling Windows authentication, you must set Windows as the authentication and authorization method for the device by using the Authentication Methods window, as described in the [Enabling Administrative Login Authentication and Authorization Schemes for WAAS Devices](#).

We recommend that you use the WAAS Central Manager GUI instead of the WAAS CLI to configure the Windows Domain server settings, but if you want to use the CLI, see the following commands in the [Cisco Wide Area Application Services Command Reference](#): **windows-domain join** and **kerberos** (if you are using Kerberos as a shared secure authentication method).

You must first configure the IP domain name and IP name server using the **ip** global configuration command.

Next, configure the appropriate NTP server using the **ntp** global configuration command.

Next, configure the windows domain administrative supergroup and normal group using the following global configuration commands:

```
WAE(config)# windows-domain administrative group super-user group_name
WAE(config)# windows-domain administrative group normal-user group_name
```

Next, register the WAAS device with the Windows domain server that you configured, by using the following command:

```
WAE# windows-domain join domain-name DomainName user UserName
```

To create a machine account in a specific organizational unit, use following command:

```
WAE# windows-domain join domain-name DomainName organization-unit OUName user UserName
```

Finally, enable Windows Domain as the administrative login authentication and authorization configuration by using the following commands:

```
WAE(config)# authentication login windows-domain enable primary
WAE(config)# authentication configuration windows-domain enable primary
```

Troubleshooting NTLM Authentication for EAPI

The following CLI commands display diagnostic information on NTLM authentication for EAPI:

```
# show windows-domain encryption-service identity
# show windows-domain encryption-service identity detail
# show windows-domain encryption-service blacklist identity
# show statistics connectoin conn-id ConnectionID
# show statistics accelerator mapi detail
```

Unregistering a WAE from a Windows Domain Controller

If you want to unregister a WAE device from a Windows domain controller, you can do that directly from the WAAS Central Manager, as long as you have used the Kerberos shared secure authentication method. If you have used the NTLM method, you cannot unregister the WAE by using the WAAS Central Manager; you must log in to the domain controller and remove the device registration manually.



Note

Before you can unregister a device, you must disable Windows authentication for the device. Also, if Encrypted MAPI is utilizing the machine account domain identity, you must remove it before performing a domain leave.

To unregister a WAE device, follow these steps:

- Step 1** From the WAAS Central Manager menu, choose **Devices** > *device-name* (or **Device Groups** > *device-name*).
- Step 2** Choose **Configure** > **Security** > **AAA** > **Authentication Methods**.
The Authentication and Authorization Methods window appears. (See [Figure 7-6](#).)
- Step 3** Under both the Authentication Login Methods and the Authorization Methods sections, change the value WINDOWS that is already chosen by choosing another value from the drop-down lists. For more information about changing these settings, see [Enabling Administrative Login Authentication and Authorization Schemes for WAAS Devices](#).
- Step 4** Click **Submit** to save the settings.
- Step 5** Choose **Configure** > **Security** > **Windows Domain** > **Domain Settings**. If your WAAS device (or device group) is running a previous version of the software, click the **Domain Join** tab.
- Step 6** (Optional) Enter the administrative username and password in the Administrator Username, Password, and Confirm Password fields. The domain controller requires the username and password to perform the unregistration.
- Step 7** Click **Leave**.

**Note**

When you click Leave, WAAS Central Manager immediately sends an unregistration request to the WAAS device (or device group) using SSH. The unregistration request instructs the device to unregister from the specified Windows Domain Controller.

Request to unregister the device is not allowed when encrypted MAPI is configured to use machine accounts. You must delete the machine account identity before proceeding with the leave.

The status of the unregistration request is shown in the Domain Join Status table.

- Step 8** If your WAAS device (or device group) is running a previous version of the software, check the status of the unregistration request by waiting a few minutes and click **Show Join Status**.

If you want to use the CLI to unregister a WAE device, you must first use the following commands to disable windows authentication:

```
WAE(config)# no authentication login windows-domain enable
WAE(config)# no authentication configuration windows-domain enable
```

**Note**

If an Encrypted MAPI machine account identity has been configured, then it has to be removed first. Use the **no windows-domain encryption-service** global configuration command to remove a machine account identity.

Next, unregister the WAAS device from the Windows domain server by using the following command (for Kerberos authentication):

```
WAE# windows-domain leave user UserName password Password
```

There is no CLI command to unregister the WAAS device if it is using NTLM authentication.

LDAP Server Signing

Lightweight Directory Access Protocol (LDAP) server signing is a configuration option of the Microsoft Windows Server's Network security settings. This option controls the signing requirements for LDAP clients. LDAP signing is used to verify that an intermediate party did not tamper with the LDAP packets on the network and to guarantee that the packaged data comes from a known source. Windows Server 2003 administration tools use LDAP signing to secure communications between running instances of these tools and the servers that they administer.

By using the Transport Layer Security (TLS, RFC 2830) protocol to provide communications privacy over the Internet, client/server applications can communicate in a way that prevents eavesdropping, tampering, or message forging. TLS v1 is similar to Secure Sockets Layer (SSL). TLS offers the same encryption on regular LDAP connections (ldap://:389) as SSL, while operating on a secure connection (ldaps://:636). A server certificate is used by the TLS protocol to provide a secure, encrypted connection to the LDAP server. A client certificate and key pair are required for client authentication.

In the WAAS software, login authentication with Windows 2003 domains is supported when the *LDAP server signing requirements* option for the Domain Security Policy is set to "Require signing." The LDAP server signing feature allows the WAE to join the domain and authenticate users securely.

**Note**

When you configure your Windows domain controller to require an LDAP signature, you must also configure LDAP signing on the client WAE. By not configuring the client to use LDAP signatures, communication with the server is affected, and user authentication, group policy settings, and login scripts might fail. Install the Certification Authority service on the Microsoft server with the server's certificate (**Programs > Administrative Tools > Certification Authority**). Enable the LDAP server signing requirements property on the Microsoft server (**Start > Programs > Administrative Tools > Domain Controller Security Policy**). In the window that is displayed, choose **Require signing** from the drop-down list, and click **OK**.

For information about how to configure your Windows domain controller to require an LDAP signature, see your Microsoft documentation.

This section contains the following topics:

- [Configuring LDAP Signing on the Client WAEs](#)
- [Disabling LDAP Server Signing on a Client WAE](#)

Configuring LDAP Signing on the Client WAEs

You can configure a security setting on Windows 2003 domain controllers to require clients (such as WAEs) to sign LDAP requests. Because unsigned network traffic can be intercepted and manipulated by outside parties, some organizations require LDAP server signing to prevent man-in-the-middle attacks on their LDAP servers. You configure LDAP signing only on a single WAE; it cannot be configured at a system level. In addition, you must configure LDAP signing on a WAE through the WAAS CLI; you cannot configure LDAP signing through any of the WAAS GUI.

By default, LDAP server signing is disabled on a WAE. To enable this feature on a WAE, follow these steps:

-
- Step 1** Enable LDAP server signing on the WAE:
- ```
WAE# configure
WAE(config)# smb-conf section "global" name "ldap ssl" value "yes"
```
- Step 2** Save the configuration on the WAE:
- ```
WAE(config)# exit
WAE# copy run start
```
- Step 3** Verify the current running LDAP client configuration on the WAE:
- ```
WAE# show smb-conf
```
- Step 4** Register the WAE with the Windows domain:
- ```
WAE# windows-domain diagnostics net "ads join -U username%password"
```
- Step 5** Enable user login authentication on the WAE:
- ```
WAE# configure
WAE(config)# authentication login windows-domain enable primary
```
- Step 6** Enable user login authorization on the WAE:
- ```
WAE(config)# authentication configuration windows-domain enable primary
```
- Step 7** Check the current configuration for login authentication and authorization on the WAE:

```

WAE# show authentication user
Login Authentication: Console/Telnet/Ftp/SSH Session
-----
local                               enabled (secondary)
Windows domain                       enabled (primary)
Radius                                disabled
Tacacs+                              disabled

Configuration Authentication: Console/Telnet/Ftp/SSH Session
-----
local                               enabled (primary)
Windows domain                       enabled (primary)
Radius                                disabled
Tacacs+                              disabled

```

The WAE is now configured to authenticate Active Directory users, who can use Telnet, FTP, or SSH to connect to the WAE. Alternatively, they can access the WAE through the WAAS GUI.

- Step 8** View statistics that are related to Windows domain user authentication. Statistics increment after each user authentication attempt:

```

WAE# show statistics windows-domain
Windows Domain Statistics
-----
Authentication:
  Number of access requests:          9
  Number of access deny responses:    3
  Number of access allow responses:   6
Authorization:
  Number of authorization requests:   9
  Number of authorization failure responses: 3
  Number of authorization success responses: 6
Accounting:
  Number of accounting requests:      0
  Number of accounting failure responses: 0
  Number of accounting success responses: 0

WAE# show statistics authentication
Authentication Statistics
-----
Number of access requests:          9
Number of access deny responses:    3
Number of access allow responses:   6

```

- Step 9** Use the **clear statistics EXEC** command to clear the statistics on the WAE:
- To clear all the login authentication statistics, enter the **clear statistics authentication EXEC** command.
 - To clear only the statistics that are related to Windows domain authentication, enter the **clear statistics windows-domain EXEC** command.
 - To clear all the statistics, enter the **clear statistics all EXEC** command.

Disabling LDAP Server Signing on a Client WAE

To disable LDAP server signing on a WAE, follow these steps:

- Step 1** Unregister the WAE from the Windows domain:

```

WAE# windows-domain diagnostics net "ads leave -U Administrator"

```

Step 2 Disable user login authentication:

```
WAE# configure
WAE(config)# no authentication login windows-domain enable primary
```

Step 3 Disable LDAP signing on the WAE:

```
WAE(config)# no smb-conf section "global" name "ldap ssl" value "yes"
```

Enabling Administrative Login Authentication and Authorization Schemes for WAAS Devices

This section describes how to centrally enable the various administrative login authentication and authorization schemes (the authentication configuration) for a WAAS device or device group.



Caution

Make sure that RADIUS, TACACS+, or Windows domain authentication is configured and operating correctly before disabling local authentication and authorization. If you disable local authentication, and if RADIUS, TACACS+, or Windows domain authentication is not configured correctly, or if the RADIUS, TACACS+, or Windows domain server is not online, you will be unable to log in to the WAAS device.

By default, a WAAS device uses the local database to authenticate and authorize administrative login requests. The WAAS device verifies whether all the authentication databases are disabled, and if so, sets the system to the default state. For information on this default state, see [Default Administrative Login Authentication and Authorization Configuration](#).



Note

You must configure the TACACS+, RADIUS, or Windows server settings for the WAAS device (or device group) before you configure and submit these settings. For information on how to configure these server settings on a WAAS device or device group, see [About TACACS+ Server Authentication Settings](#), and [Configuring RADIUS Server Authentication Settings](#), and [Configuring Windows Domain Server Authentication Settings](#).

By default, WAAS devices fail over to the secondary method of administrative login authentication whenever the primary administrative login authentication method fails for any reason. Change this default login authentication failover method through the WAAS Central Manager GUI, as follows:

- To change the default for a WAAS device, choose **Devices** > *device-name* and then choose **Configure** > **Security** > **AAA** > **Authentication Methods** from the menu. Check the **Failover to next available authentication method** box in the displayed window and click **Submit**.
- To change the default for a device group, choose **Device Groups** > *device-group-name* and then choose **Configure** > **Security** > **AAA** > **Authentication Methods** from the menu. Check the **Failover to next available authentication method** box in the displayed window and click **Submit**.

After you enable the failover to next available authentication method option, the WAAS device (or the devices in the device group) queries the next authentication method only if the administrative login authentication server is unreachable, not if authentication fails for some other reason. The authentication server could be unreachable due to an incorrect key in the RADIUS or TACACS+ settings on the WAAS device.

You can configure multiple TACACS+ or RADIUS servers; authentication is attempted on the primary server first. If the primary server is unreachable, then authentication is attempted on the other servers in the TACACS+ or RADIUS farm, in order. If authentication fails for any reason other than a server being unreachable, authentication is not attempted on the other servers in the farm. This process applies regardless of the setting of the **Failover to next available authentication method** check box.



Note To use the login authentication failover feature, you must set TACACS+, RADIUS, or Windows domain as the primary login authentication method, and local as the secondary login authentication method.

If the failover to the next available authentication method option is *enabled*, follow these guidelines:

- You can configure only two login authentication schemes (a primary and secondary scheme) on the WAAS device.
- Note that the WAAS device (or the devices in the device group) fails over from the primary authentication scheme to the secondary authentication scheme only if the specified authentication server is unreachable.
- Configure the local database scheme as the secondary scheme for both authentication and authorization (configuration).

For example, if the failover to next available authentication method option is enabled and RADIUS is set as the primary login authentication scheme and local is set as the secondary login authentication scheme, the following events occur:

1. When the WAAS device (or the devices in the device group) receives an administrative login request, it queries the external RADIUS authentication server.
2. One of the following occurs:
 - a. If the RADIUS server is reachable, the WAAS device (or the devices in the device group) uses this RADIUS database to authenticate the administrator.
 - b. If the RADIUS server is not reachable, the WAAS device (or the devices in the device group) tries the secondary authentication scheme (that is, it queries its local authentication database) to authenticate the administrator.



Note The local database is contacted for authentication only if this RADIUS server is not available. In any other situation, for example, if the authentication fails in the RADIUS server, the local database is not contacted for authentication.

Conversely, if the failover to the next available authentication method option is *disabled*, the WAAS device (or the devices in the device group) contacts the secondary authentication database regardless of the reason why the authentication failed with the primary authentication database.

If all the authentication databases are enabled for use, then all the databases are queried in the order of priority selected and based on the failover reason. If no failover reason is specified, then all the databases are queried in the order of their priority. For example, first the primary authentication database is queried, then the secondary authentication database is queried, then the tertiary database is queried, and finally the quaternary authentication database is queried.

To specify the login authentication and authorization scheme for a WAAS device or device group, follow these steps:

Step 1 From the WAAS Central Manager menu, choose **Devices** > *device-name* (or **Device Groups** > *device-group-name*).

Step 2 Choose **Configure** > **Security** > **AAA** > **Authentication Methods**.

The Authentication and Authorization Methods window appears. (See Figure 7-6.)

Figure 7-6 Authentication and Authorization Methods Window

Step 3 Check the **Failover to next available authentication method** check box to query the secondary authentication database only if the primary authentication server is unreachable. When the check box is unchecked, the other authentication methods are tried if the primary method fails for any reason.

To use this feature, you must set TACACS+, RADIUS, or Windows domain as the primary authentication method, and local as a secondary authentication method. Make sure that you configure the local method as a secondary scheme for both authentication and authorization (configuration).

Check the **Use only local admin account to enable privilege exec level** check box to configure enable authentication by using the local admin user account password. In this case, the request for enable access is not sent to the external authentication servers, but is processed on the WAE. It uses only the local “admin” user account password to verify the given password, and to provide access.

Step 4 Check the **Authentication Login Methods** check box to enable authentication privileges using the local, TACACS+, RADIUS, or WINDOWS databases.

Step 5 Specify the order of the login authentication methods that the chosen device or device group are to use:

- a. From the Primary Login Method drop-down list, choose **local**, **TACACS+**, **RADIUS**, or **WINDOWS**. This option specifies the first method that the chosen device (or the device group) should use for administrative login authentication.
- b. From the Secondary Login Method drop-down list, choose **local**, **TACACS+**, **RADIUS**, or **WINDOWS**. This option specifies the method that the chosen device (or the device group) should use for administrative login authentication if the primary method fails.

- c. From the Tertiary Login Method drop-down list, choose **local**, **TACACS+**, **RADIUS**, or **WINDOWS**. This option specifies the method that the chosen device (or the device group) should use for administrative login authentication if both the primary and the secondary methods fail.
- d. From the Quaternary Login Method drop-down list, choose **local**, **TACACS+**, **RADIUS**, or **WINDOWS**. This option specifies the method that the chosen device (or device group) should use for administrative login authentication if the primary, secondary, and tertiary methods all fail.



Note We strongly recommend that you specify the local method as the last method in your prioritized list of login authentication and authorization methods. By adhering to this practice, the WAAS administrator will be able to log in to a WAAS device (or the devices in the device groups) through the local authentication and authorization method if the specified external third-party servers (TACACS+, RADIUS, or Windows domain servers) are not reachable.

- Step 6** Check the **Authorization Methods** check box to enable authorization privileges using the local, TACACS+, RADIUS, or WINDOWS databases.



Note Authorization privileges apply to console and Telnet connection attempts, secure FTP (SFTP) sessions, and Secure Shell (SSH Version 2) sessions.

- Step 7** Specify the order of the login authorization (configuration) methods that the chosen device (or the device group) should use:



Note We strongly recommend that you set the administrative login authentication and authorization methods in the same order. For example, configure the WAAS device (or device group) to use RADIUS as the primary login method, TACACS+ as the secondary login method, Windows as the tertiary method, and the local method as the quaternary method for both administrative login authentication and authorization.

- a. From the Primary Configuration Method drop-down list, choose **local**, **TACACS+**, **RADIUS**, or **WINDOWS**. This option specifies the first method that the chosen device (or the device group) should use to determine authorization privileges.



Note If you have checked the **Failover to next available authentication method** check box (Step 3), make sure that you choose **TACACS+ or RADIUS** from the Primary Configuration Method drop-down list to configure either the TACACS+ or RADIUS method as the primary scheme for authorization (configuration).

- b. From the Secondary Configuration Method drop-down list, choose **local**, **TACACS+**, **RADIUS**, or **WINDOWS**. This option specifies the method that the chosen device (or the device group) should use to determine authorization privileges if the primary method fails.



Note If you have checked the **Failover to next available authentication method** check box (Step 3), make sure that you choose **local** from the Secondary Configuration Method drop-down list to configure the local method as the secondary scheme for authorization (configuration).

- c. From the Tertiary Configuration Method drop-down list, choose **local**, **TACACS+**, **RADIUS**, or **WINDOWS**. This option specifies the method that the chosen device (or the device group) should use to determine authorization privileges if both the primary and secondary methods fail.
- d. From the Quaternary Configuration Method drop-down list, choose **local**, **TACACS+**, **RADIUS**, or **WINDOWS**. This option specifies the method that the chosen device (or device group) should use to determine authorization privileges if the primary, secondary, and tertiary methods all fail.

Step 8 To refresh the authentication status, check the check box and click **Show Windows Authentication Status**. This option is only available when Windows is set as the authentication and authorization methods.

A dialog box prompts you about whether or not you want to continue with this request to refresh the status of the authentication request. (See [Figure 7-7](#).)

Figure 7-7 Confirmation Dialog Box

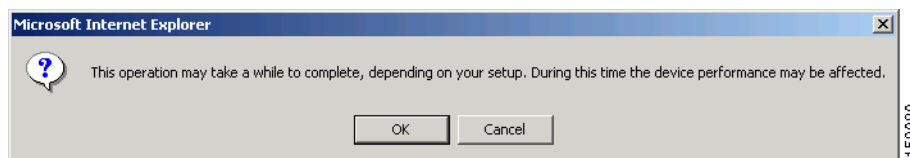

Step 9 Click **OK** to continue or **Cancel** to cancel the request.

If the request fails, an error dialog box is displayed. Wait for a few more minutes and try again to see the updated authentication status.

Step 10 Click **Submit** to save the settings.



Note If you have enabled the Windows authentication or authorization method, the Central Manager queries the WAE (of Version 4.2.1 or later) to ensure that it is registered to a Windows domain. This can take up to one minute after you click **Submit**. You will see a message asking you to confirm this process. Click **OK** to proceed. If you are configuring a WAE of Version 4.1.x or earlier, or a device group, the Central Manager does not query the WAEs and you must ensure that each WAE is properly registered. You will see a message informing you that system behavior is unknown (if a WAE is unregistered). Click **OK** to proceed.



Note If you have enabled the Windows authentication method, it takes about 15 seconds to activate it. Wait for at least 15 seconds before verifying the Windows authentication status or performing any operation that requires Windows authentication.

To configure the login authentication and authorization scheme from the CLI, use the **authentication** global configuration command. Before you enable Windows domain authentication or authorization for a device, the device must be registered with the Windows domain controller.

Configuring AAA Command Authorization

Command authorization enforces authorization through an external AAA server for each command executed by the CLI user. All the commands executed by a CLI user are authorized before they are executed. RADIUS, Windows domain, and local users are not affected.

**Note**

Only commands executed through the CLI interface are subject to command authorization.

When command authorization is enabled, you must specify "permit null" on the TACACS+ server to allow authorized commands with no arguments to be executed.

To configure command authorization for a WAAS device or device group, follow these steps:

- Step 1** From the WAAS Central Manager menu, choose **Devices > device-name** (or **Device Groups > device-group-name**).
- Step 2** Choose **Configure > Security > AAA > Command Authorization Settings**.
The Command Authorization window appears.
- Step 3** Check the Command Authorization Level check box to mark the desired level:
 - Level 0—Only EXEC commands are authorized by the TACACS+ server before they are executed, regardless of user level (normal or super). Global configuration commands are not allowed.
 - Level 15—Both EXEC and global configuration level commands are authorized by the TACACS+ server before they are executed, regardless of user level (normal or super).

**Note**

You must have a TACACS+ server configured before you can configure command authorization.

- Step 4** Click **Submit** to save the settings.

Configuring Cisco Prime Network Control System Single Sign-On

New IOS/WAAS features, such as AppNav and kWAAS, require the use of both WAAS and Cisco Prime Network Control System (NCS) management systems at the same time. Lack of integration between the NCS and WAAS CM impairs user experience. NCS Single Sign-On (SSO) functionality provides a way to integrate these two systems and seamlessly launch the WAAS CM from NCS.

The NCS integration has the following prerequisites:

- The NCS device is running the 2.x code.
- The Cisco IOS-XE device must be running 3.10 code.
- The Cisco WAAS 5.3.0 or later Central Manager is installed and configured.
- The IOS-XE device with kWAAS instance is configured.
- The kWAAS instance is registered with the WAAS CM.

To configure the NCS, follow the steps below:

-
- Step 1** Configure the NCS device. For more information, see [Configuring the NCS Device](#).
 - Step 2** Configure the WAAS CM. For more information, see [Configuring the WAAS CM to use SSO](#).
 - Step 3** Use the Single Sign-on feature. For more information, see [Launching WAAS CM from NCS](#).

Configuring the NCS Device

To configure the NCS Server follow these steps:

-
- Step 1** Log in to Prime NCS to add the SSO server:
 - a. Choose **Administration > Users, Roles & AAA > SSO servers**.
 - b. Enter the SSO server information, then click **Save**.



Note If you use an external Cisco Prime host for SSO, specify the IP address of that host. If you do not currently use the SSO functionality to log in to Cisco Prime, use the IP address of the Cisco Prime device itself.

- Step 2** To enable SSO authentication:
 - a. Choose **Administration > Users, Roles & AAA > AAA mode**.
 - b. Click the **SSO mode** radio button. Click **Save**.
- Step 3** To configure WAAS CM address:
 - a. Choose **Administration > System Settings > Service Container Management** and enter the WAAS CM Ip address in the **WCM IP Address** field.
 - b. Click **Save**.

Configuring the WAAS CM to use SSO

To configure the WAAS CM to use SSO follow these steps:

-
- Step 1** From the WAAS Central Manager menu, choose **Admin > AAA > Users** to configure a NCS user account.
The User Accounts window displays all the user accounts on the system.
 - Step 2** Click the **Create New User Accounts** icon.
The **Creating New User Account** window appears. Create a new non-local (remote) user account with the name matching exactly the name of the NCS SSO user. Assign needed roles and domains in the **Role Management** and **Domain Management** windows.
 - Step 3** To configure the NCS server from the WAAS CM:
 - a. From the WAAS Central Manager menu, choose **Devices > WAAS CM > Configure AAA > Cisco Prime SSO**
 - b. Check the **Enable NCS Single Sign-on** check box, enter the NCS SSO server URL to configure the SSO server. Click **Submit**.
 - c. Verify Server Certificate and click Submit.
The SSO feature is now ready for use.

Launching WAAS CM from NCS

To launch WAAS CM from NCS follow these steps:

Step 1 Go to Cisco Prime Server and select the appropriate device from the Service Container.

Step 2 Click the **WAAS CM UI** tab to launch the WAAS CM GUI.

Alternatively, select the device to launch the device instance homepage in the WAAS CM GUI.

Configuring AAA Accounting for WAAS Devices

Accounting tracks all user actions and when the actions occurred. It can be used for an audit trail or for billing connection time or resources used (bytes transferred). Accounting is disabled by default.

The WAAS accounting feature uses TACACS+ server logging. Accounting information is sent only to the TACACS+ server, not to the console or any other device. The syslog file on the WAAS device logs accounting events locally. The format of events stored in the syslog is different from the format of accounting messages.

The TACACS+ protocol allows effective communication of AAA information between WAAS devices and a central server. It uses TCP for reliable connections between clients and servers. WAAS devices send authentication and authorization requests, as well as accounting information to the TACACS+ server.

**Note**

Before you can configure the AAA accounting settings for a WAAS device, you must first configure the TACACS+ server settings for the WAAS device. (See [About TACACS+ Server Authentication Settings](#).)

**Note**

If you enable AAA accounting for a device, we strongly recommended that you create an IP ACL condition in the first entry position permitting access to the TACACS+ servers to avoid delay while processing the commands. For information on IP ACLs, see [Chapter 9, “Creating and Managing IP Access Control Lists for Cisco WAAS Devices.”](#)

To centrally configure AAA accounting settings for a WAAS device or device group, follow these steps:

Step 1 From the WAAS Central Manager menu, choose **Devices** > *device-name* (or **Device Groups** > *device-group-name*).

Step 2 Choose **Configure** > **Security** > **AAA** > **AAA Accounting**.

The AAA Accounting Settings window appears.

Step 3 From the **System Events** drop-down list, choose a keyword to specify when the chosen device (or the device group) should track system-level events that are not associated with users, such as reloads, and to activate accounting for system events.

Step 4 From the **Exec Shell and Login/Logout Events** drop-down list, choose a keyword to specify when the chosen device (or the device group) should track EXEC shell and user login and logout events and to activate accounting for EXEC mode processes. Reports include username, date, start and stop times, and the WAAS device IP address.

- Step 5** From the **Normal User Commands** drop-down list, choose a keyword to specify when the chosen device (or the device group) should track all the commands at the normal user privilege level (privilege level 0) and to activate accounting for all the commands at the nonsuperuser administrative (normal user) level.
- Step 6** From the **Administrative User Commands** drop-down list, choose a keyword to specify when the chosen device (or the device group) should track all commands at the superuser privilege level (privilege level 15) and to activate accounting for all the commands at the superuser administrative user level.

**Caution**

Before using the **wait-start** option, ensure that the WAAS device is configured with the TACACS+ server and is able to successfully contact the server. If the WAAS device cannot contact a configured TACACS+ server, it might become unresponsive.

Table 7-3 describes the event type options.

Table 7-3 *Event Types for AAA Accounting*

GUI Parameter	Function
Event Type Options	
stop-only	The WAAS device sends a stop record accounting notice at the end of the specified activity or event to the TACACS+ accounting server.
start-stop	The WAAS device sends a start record accounting notice at the beginning of an event and a stop record at the end of the event to the TACACS+ accounting server. The start accounting record is sent in the background. The requested user service begins regardless of whether or not the start accounting record was acknowledged by the TACACS+ accounting server.
wait-start	The WAAS device sends both a start and a stop accounting record to the TACACS+ accounting server. However, the requested user service does not begin until the start accounting record is acknowledged. A stop accounting record is also sent.
Do Not Set	Accounting is disabled for the specified event.

- Step 7** Check the **Enable CMS CLI Accounting** check box to enable AAA accounting to TACACS+ server.
- Step 8** Click **Submit** to save the settings.

To configure AAA accounting settings from the CLI, use the **aaa accounting** global configuration command.

Viewing Audit Trail Logs

The WAAS Central Manager device logs user activity in the system. The only activities that are logged are those activities that change the WAAS network. For more information on viewing a record of user activity on your WAAS system, see [Viewing the Audit Trail Log](#) in Chapter 16, Troubleshooting Your WAAS Network.”



Creating and Managing Administrator User Accounts and Groups

This chapter describes how to create user accounts and groups from the Cisco Wide Area Applications Services Central Manager GUI.



Note

Throughout this chapter, the term Cisco WAAS device is used to refer collectively to the WAAS Central Managers and WAEs (Cisco Wide Area Application Engines) in your network. The term WAE refers to WAE appliances, and WAE Network Modules (the Cisco WAAS NME-WAE family of devices).

This chapter contains the following sections:

- [Overview of Administrator User Accounts](#)
- [Creating and Managing User Accounts](#)

Overview of Administrator User Accounts

Your WAAS system comes with an administrator account already created, which you can use to access the WAAS Central Manager GUI as well as the WAAS CLI. This account has the username of *admin* and the password *default*. You can use the WAAS Central Manager GUI to change the password of this account.

If you want to create additional administrator user accounts, see [Table 8-1](#) for a description of the two types of accounts you can create from the WAAS Central Manager GUI.

Table 8-1 Account Type Descriptions

Account Type	Description
Roles-based account	<p>Allows you to create accounts that manage and configure specific WAAS services. For example, you may want to delegate the configuration of application acceleration to a specific administrator. In this case, you could create a roles-based account that only has access to the Acceleration pages in the WAAS Central Manager GUI.</p> <p>You can create a role-based account that also is a local user account.</p> <p>You create roles-based accounts from the Admin menu in the WAAS Central Manager GUI.</p>
Local account	<p>Provides CLI access to WAE devices. A user with this account type can log in to the WAAS Central Manager but they have the access rights assigned to the default account, which initially has no access to GUI functionality.</p> <p>We recommend that you create a local account if there is an administrator that only needs CLI access to WAE devices.</p> <p>You should create local accounts the same way as roles-based accounts, but you should check the Local User check box when creating the account.</p>

Creating and Managing User Accounts

This section contains the following topics:

- [Overview for Creating an Account](#)
- [Working with Accounts](#)
- [Working with Passwords](#)
- [Working with Roles](#)
- [Working with Domains](#)
- [Working with User Groups](#)

Overview for Creating an Account

[Table 8-2](#) provides an overview of the steps you must complete to create a new roles-based administrator account.

Table 8-2 Checklist for Creating a Roles-based Administrator Account

Task	Additional Information and Instructions
1. Create a new account.	Creates an account on the system with a specific username, password, and privilege level. For more information, see Creating a New Account .
2. Create a role for the new account.	Creates a role that specifies the services that an account can configure in your WAAS network. For more information, see Creating a New Role . If you are using an external authentication server, you can define matching user groups that automatically assign roles to users.
3. Assign the role to the new account.	Assigns the new role to the new account. For more information, see Assigning a Role to a User Account . If you are using an external authentication server, you can define matching user groups that automatically assign roles to users.

Table 8-2 Checklist for Creating a Roles-based Administrator Account (continued)

Task	Additional Information and Instructions
4. Create a domain.	Creates a domain that will specify the WAEs, device groups, or AppNav Clusters that the new account can manage. For more information, see Creating a New Domain .
5. Add an entity to the domain.	Adds one or more WAEs, device groups, or AppNav Clusters to the domain. For more information, see Adding an Entity to a Domain .
6. Assign a domain to a user account.	Assigns the domain to the new user account. For more information, see Assigning a Domain to a User Account . If you are using an external authentication server, you can define matching user groups that automatically assign domains to users.

Working with Accounts

When you create a user account, you enter information about the user, such as the username, the name of the individual who owns the account, contact information, job title, and department. All user account information is stored in an internal database on the WAAS Central Manager.

Each user account can then be assigned to a role. A *role* defines which WAAS Central Manager GUI configuration pages the user can access and which services the user has authority to configure or modify. The WAAS Central Manager provides one predefined role, known as the admin role. The admin role has access to all services. A *domain* defines the entities in the network that the user can access, configure, or modify. You can assign a user account to zero or more roles and to zero or more domains.

In addition to user accounts, you can create user groups if you are using external authentication of users on a TACACS+ or Windows domain server (not a RADIUS server). By creating user group names that match the user groups that you have defined on the external authentication server, WAAS can dynamically assign roles and domains to users based on their membership in a group as defined on the external authentication server. You do not have to define a role or domain for each user individually.

Two default user accounts are preconfigured in the WAAS Central Manager. The first account, called *admin*, is assigned the administrator role that allows access to all services, and access to all entities in the system. This account cannot be deleted from the system, but it can be modified. Only the username and the role for this account are unchangeable. Only an account that has been assigned the admin role can create other admin-level accounts.

The second preconfigured user account is called *default*. Any user account that is authenticated but has not been registered in the WAAS Central Manager obtains the access rights (role) assigned to the default account. This account is configurable by an administrator, but it cannot be deleted nor its username changed. Initially, the default account has no access to GUI functionality because it has no roles defined, although you can use the default account to log in to the WAAS Central Manager GUI.

This section contains the following topics:

- [Creating a New Account](#)
- [Modifying and Deleting a User Account](#)
- [Changing the Password for Your Own Account](#)
- [Changing the Password for Another Account](#)
- [Viewing a User Account](#)
- [Unlocking a User Account](#)

Creating a New Account

The first step in setting up an account is to create the account by specifying a username and selecting whether a local CLI account is created at the same time. After the account is created, you can assign roles to the account, which determine the WAAS services and devices that the account can manage and configure.

Table 8-3 describes the outcome of creating a local CLI user when setting up an account.

Table 8-3 Outcome of Creating a Local User

Action	Result
Creating a Local User	<ul style="list-style-type: none"> The account can be used to access the WAAS CLI and the WAAS Central Manager GUI (with the default role). Users can change their own passwords, and the password change will propagate to standby WAAS Central Managers. The account is stored in the WAAS Central Manager database and is also propagated to the standby WAAS Central Managers.
Not Creating a Local User	<ul style="list-style-type: none"> The user account is created in the primary and standby WAAS Central Manager management databases. No user account is created in the CLI. Users will have to use another account to access the CLI. The new account can be used to log in to the WAAS Central Manager GUI if an external authentication server is set. The user is assigned the roles defined for the default user (initially none). Local users can change their passwords using the WAAS Central Manager GUI only if they have roles that allow access to the Admin > AAA section.



Note

If a user account has been created from the CLI only, when you log in to the WAAS Central Manager GUI for the first time, the Centralized Management System (CMS) automatically creates a user account (with the same username as that configured in the CLI) with default authorization and access control. An account created from the CLI will initially be unable to access any configuration pages in the WAAS Central Manager GUI. You must use an admin account to give the account created from the CLI the roles it requires to perform configuration tasks from the WAAS Central Manager GUI.

To create a new account, follow these steps:

Step 1 From the WAAS Central Manager menu, choose **Admin > AAA > Users**.

The User Accounts window displays all the user accounts on the system.

Step 2 Click the **Create New User Accounts** icon.

The Creating New User Account window appears.



Note This window can be accessed only by users with administrator-level privileges.

- Step 3** In the Username field, enter the user account name.
- Step 4** Usernames are case sensitive and cannot contain characters other than letters, numbers, period, hyphen, and underscore. Complete the following steps to create a local CLI user account:
- Check the **Local User** check box. See [Table 8-3](#) for information about the benefits of creating a local CLI user. A local user is created on all WAE devices.



Note Do not create a local user with a username that is identical to a username defined in an external authentication server that is authorizing access to the WAAS device.

- In the Password field, enter a password for the local user account, and re-enter the same password in the Confirm Password field. Passwords are case-sensitive, must be 1 to 31 characters in length, and cannot contain the characters `'`, `"`, `|` (apostrophe, double quote, or pipe) or any control characters.
- From the CLI Privilege Level drop-down list, select one of the following options for the local user account:
 - 0 (normal user)**—Limits the CLI commands this user can use to only user-level EXEC commands. This is the default value.
 - 15 (super user)**—Allows this user to use privileged EXEC-level CLI commands, similar to the functions that a Central Manager GUI user with the admin role can perform.



Note Use the WAAS CLI EXEC mode for setting, viewing, and testing system operations. It is divided into two access levels: user and privileged. A local user who has *normal* privileges can only access the user-level EXEC CLI mode. A local user who has *superuser* privileges can access the privileged EXEC mode as well as all other modes, for example, configuration mode and interface mode, to perform any administrative task. For more information about the user-level and privileged EXEC modes and CLI commands, see the [Cisco Wide Area Application Services Command Reference](#).

- Step 5** (Optional) In the User Information fields, enter the following information about the user in the appropriate fields: first name, last name, phone number, e-mail address, job title, and department.
- Step 6** (Optional) In the Comments field, enter any additional information about this account.
- Step 7** Click **Submit**.
A **Changes Submitted** message appears at the bottom of the window.
- Step 8** Assign roles to this new account, as described in [Working with Roles](#) and assign domains, as described in [Working with Domains](#).
-

Modifying and Deleting a User Account



Note Modifying a user account from the CLI does not update the Centralized Management System (CMS) database and the change will not be reflected in the Central Manager GUI.

To modify an existing user account, follow these steps:

Step 1 From the WAAS Central Manager menu, choose **Admin > AAA > Users**.

The User Accounts window appears.

Step 2 Click the **Edit** icon next to the user account that you want to modify.



Note This window can only be accessed by users with administrator-level privileges.

The Modifying User Account window appears. You can delete or edit user accounts as follows:

- To delete the user account, click the **Delete** icon in the taskbar, and then click **OK** to confirm the deletion.

If the local user account was created using the WAAS Central Manager GUI, the corresponding user account is removed from the CLI and is also deleted from all standby WAAS Central Managers.



Note Deleting a user account from the CLI does *not* disable the corresponding user account in the CMS database. Consequently, the user account remains active in the CMS database. User accounts created in the WAAS Central Manager GUI should always be deleted from the WAAS Central Manager GUI.

- To edit the user account, make the necessary changes to the username and account information, and click **Submit**.

Changing the Password for Your Own Account

If you are logged in to the WAAS Central Manager GUI, you can change your own account's password if you meet the following requirements:

- Your account and password were created in the WAAS Central Manager GUI and not in the CLI.
- You are authorized to access the password window.



Note We do not recommend changing the local CLI user password from the CLI. Any changes to local CLI user passwords from the CLI are not updated in the management database and are not propagated to the standby WAAS Central Manager. Therefore, passwords in the management database will not match a new password configured in the CLI.



Note The advantage of initially setting passwords from the WAAS Central Manager GUI is that both the primary and the standby WAAS Central Managers will be synchronized, and GUI users will not have to access the CLI to change their password.

To change the password for your own account, follow these steps:

Step 1 From the WAAS Central Manager menu, choose **Admin > Security > Password**.

The Changing Password for User Account window appears.

- Step 2** In the New Password field, enter the changed password. Passwords are case sensitive, must be 1 to 31 characters in length, and cannot contain the characters ` ` , ` " , ` |` (apostrophe, double quote, or pipe) or any control characters.
- Step 3** In the Confirm New Password field, re-enter the password for confirmation.
- Step 4** Click **Submit**.
- The message **Changes Submitted** appears at the bottom of the window confirming that your password has been changed.
-

When you change the password of an account by using the WAAS Central Manager GUI, it changes the password for all WAE devices managed by the Central Manager.

Changing the Password for Another Account

If you log in to the WAAS Central Manager GUI using an account with admin privileges, you can change the password of any other account.



Note

If you change a user password from the CLI, the password change applies only to the local device, will not be reflected in the Central Manager GUI, and is not propagated to any other devices.

To change the password for another account, follow these steps:

- Step 1** From the WAAS Central Manager menu, choose **Admin > AAA > Users**.
A list of roles-based user accounts appears.
- Step 2** Click the **Edit** icon next to the account that needs a new password.
The Modifying User Account window appears.
- Step 3** In the Password field, enter the changed password. Passwords are case-sensitive, must be 1 to 31 characters in length, and cannot contain the characters ` ` , ` " , ` |` (apostrophe, double quote, or pipe) or any control characters.
- Step 4** In the Confirm Password field, reenter the password for confirmation.
- Step 5** Click **Submit**.
- The message **Changes Submitted** appears at the bottom of the window confirming that your password has been changed.
-

Viewing a User Account

To view all user accounts, choose **Admin > AAA > Users** from the WAAS Central Manager GUI. The User Accounts window displays all the user accounts in the management database. From this window, you can also create new accounts, as described in [Creating a New Account](#).

To view user accounts for a specific device, choose **Devices > device-name** and then choose **device-name > Device Users** or **CM Users**, depending on the device mode. The Users for device window displays all the user accounts defined for the device.

To view the details of an account, click the **View** icon next to the account.

Unlocking a User Account

When a user account is locked out, the user cannot log in to the WAAS device until an administrator unlocks the account. A user account will be locked out if the user unsuccessfully tries to log in three consecutive times.

To unlock an account, follow these steps:

-
- Step 1** From the WAAS Central Manager GUI, choose **Admin > AAA > Users**.
The User Accounts listing window appears and displays the status of each user account.



Note This window can only be accessed by users with administrator-level privileges.

- Step 2** Click the **Edit** icon next to the user account that you want to modify.
The Modifying User Account window appears and displays a list of devices on which this account is locked out.
- Step 3** Choose the device in which you want to unlock the account.
The list of device users appears.
- Step 4** Choose the user or users to unlock, and click **unlock**.
-

Working with Passwords

The WAAS system features two levels of password policy: *standard* and *strong*. By default, the standard password policy is enabled.

To change the password policy, follow these steps:

-
- Step 1** From the WAAS Central Manager menu, choose **Devices > device-name** (or **Device Groups > device-group-name**).
- Step 2** Choose **Configure > Security > AAA > Password Policy Settings**.
- Step 3** Check the **Enforce stringent password** check box to enable the strong password policy.
- Step 4** In the **Maximum login retries** field, enter the maximum number of login attempts to be allowed before a user is locked out. The user remains locked out until cleared by the administrator. For information about how to clear a locked-out account, see [Unlocking a User Account](#).
- Step 5** Click **Submit** to save your changes.
-

To configure a password policy from the CLI, use the **authentication strict-password-policy** global configuration command.

When the standard password policy is enabled, user passwords must meet the following requirements:

- The password must be 1 to 31 characters long.
- The password can include both uppercase and lowercase letters (A–Z and a–z) and numbers (0 to 9).
- The password cannot contain the characters ` ` ` | (apostrophe, double quote, or pipe) or any control characters.

When the strong password policy is enabled, user passwords must meet the following requirements:

- The password must be 8 to 31 characters long.
- The password can include both uppercase and lowercase letters (A–Z and a–z), numbers (0 to 9), and special characters including ~, ` , ! , @ , # , \$, % , ^ , & , * , (,) , _ , + , - , = , [,] , \ , { , } , ; , : , < , / , > .
- The password cannot contain the characters ` ` ` | (apostrophe, double quote, or pipe) or any control characters.
- The password cannot contain all the same characters (for example, 99999).
- The password cannot contain consecutive characters (for example, 12345).
- The password cannot be the same as the username.
- Each new password must be different from the previous 12 passwords. User passwords expire within 90 days.
- The password cannot contain dictionary words.

A user account will be locked out after the configured number of failed login attempts (the default is three). The user remains locked-out until cleared by the administrator. For information on how to clear a locked-out account, see [Unlocking a User Account](#).

Working with Roles

The WAAS Central Manager GUI allows you to create roles for your WAAS system administrators so that each administrator can focus on configuring and managing a specific WAAS service. For example, you can set up a role that allows an administrator to create and modify application policies, but does not allow the administrator to make any other changes to the system.

You can think of a role as a set of enabled services. Make sure you have a clear idea of the services that you want the role to be responsible for because you will select these services when you create the role. After you create a role, you can assign the role to existing accounts, as described later in this chapter.

A role can give read and write or read-only access to each enabled service.

Each user account or group can be assigned to zero or more roles. Roles are not inherited or embedded. The WAAS Central Manager provides a predefined role, known as the admin role. The admin role has access to all services, similar to a CLI user having privilege level 15. Without the admin role, a user will not be able to perform all the administrative tasks.



Note

Assigning the admin role to a user does not change the user privilege level to 15. The user must also have privilege level 15 in order to perform administrative tasks.

WAAS can dynamically assign a role to users based on their membership in a group as defined on an external TACACS+ or Windows domain authentication server. To take advantage of this feature, you must define user group names on the WAAS Central Manager that match the user groups defined on the external authentication server, and assign a role to the user groups on the WAAS Central Manager. For more information on user groups, see [Working with User Groups](#).

This section contains the following topics:

- [Creating a New Role](#)
- [Assigning a Role to a User Account](#)
- [Modifying and Deleting a Role](#)
- [Viewing Role Settings](#)

Creating a New Role

To create a new role, follow these steps:

-
- Step 1** From the WAAS Central Manager menu, choose **Admin > AAA > Roles**.
The Roles listing window appears.
- Step 2** Click the **Create New Role** icon from the taskbar.
The Creating New Role window appears.
- Step 3** In the Name field, enter the name of the role.
The name cannot contain characters other than letters, numbers, period, hyphen, underscore, and space.
- Step 4** Check the check box next to the services you want this role to manage.
The check boxes in this window are tri-state check boxes. When there is a check in a check box, it means that the user will have read and write access to the listed service. Click the check box again to change the indicator to a square partially filling the check box. This indicator means that the user will have read-only access to the service. An empty square signifies no access to the service.
To expand the listing of services under a category, click the folder icon, and then check the check box next to the services you want to enable for this role. To choose all the services under one category simultaneously, check the check box next to the top-level folder for those services.

[Table 8-4](#) lists the services that you can enable for a role.

Table 8-4 Description of Cisco WAAS Services

Service	Description
Home	Allows a role to view, configure, and manage the system dashboard and settings in the Configure, Monitor, and Admin menus of the WAAS Central Manager GUI in the Home (global) context. Under each folder you can select the subpages that you want this role to manage.
Device Groups	Allows a role to view, configure, and manage the settings and subpages for the various device groups in the WAAS Central Manager GUI in the device group context.
Devices	Allows a role to view, configure, and manage the settings and subpages for various kinds of devices in the WAAS Central Manager GUI in the device context.
AppNav Clusters	Allows a role to view, configure, and manage the settings and subpages in the WAAS Central Manager GUI in the AppNav Cluster context.
Locations	Allows a role to view, configure, and manage the settings and subpages in the WAAS Central Manager GUI in the Location context.

Table 8-4 Description of Cisco WAAS Services (continued)

Service	Description
All Devices	<p>Allows a role to access all the devices in your WAAS network. If this service is not enabled, the user account will only have access to the devices associated with the domain that you assign to the account.</p> <p>Selecting this service allows you to skip the following tasks when setting up a roles-based account:</p> <ul style="list-style-type: none"> • Creating and maintaining a domain that contains all the devices in your network. • Assigning to the account the domain that contains all the devices.
All Device Groups	<p>Allows a role to access all the device groups in your WAAS network. If this service is not enabled, the user account will only have access to the device groups associated with the domain that you assigned to the account.</p> <p>Selecting this service allows you to skip the following tasks when setting up a roles-based account:</p> <ul style="list-style-type: none"> • Creating and maintaining a domain that contains all the device groups in your network. • Assigning to the account the domain that contains all the device groups.
All AppNav Clusters	<p>Allows a role to access all the AppNav Clusters in your WAAS network. If this service is not enabled, the user account will only have access to the AppNav Clusters associated with the domain that you assign to the account.</p> <p>Selecting this service allows you to skip the following tasks when setting up a roles-based account:</p> <ul style="list-style-type: none"> • Creating and maintaining a domain that contains all the AppNav Clusters in your network. • Assigning to the account the domain that contains all the AppNav Clusters.
Monitoring API	<p>Allows a role to access monitoring APIs through HTTPS requests. For more information, see Cisco Wide Area Application Services API Reference.</p>
System Status	<p>Allows a role to access the device Alarms panel. For more information about device alarms, see Chapter 15, “Monitoring Your WAAS Network.”</p>

Step 5 (Optional) Enter comments, if any, about this role in the Comments field.

Step 6 Click **Submit** to save your settings.

Assigning a Role to a User Account

After you create a role, you must assign the role to an account (or a user group). If you create an account, but do not assign a role to the account, the user for that account can log in to the WAAS Central Manager GUI but no data will be displayed and the configuration pages will not be available.

**Note**

The admin user account, by default, is assigned to the role that allows access to all entities in the system. It is not possible to change the role for this user account.

To assign one or more roles to a user account group, follow these steps:

-
- Step 1** From the WAAS Central Manager menu, choose **Admin > AAA > Users** (or **Admin > AAA > User Groups**).
- The User Accounts (or User Groups) window appears with all the configured user accounts listed.
- Step 2** Click the **Edit** icon next to the user account or group for which you want to assign roles.
- The Modifying User Account (or Modifying User Group) window appears.
- Step 3** Click the **Role Management** tab.
- The Role Management window appears with all the configured role names listed.
- Step 4** Click the **Assign** icon (blue cross mark) that appears next to the role name you want to assign to the selected user account or group.
- Step 5** Click the **Unassign icon** (green tick mark) next to the role name to unassign a previously assigned role.

**Note**

Click the **Assign all Roles** icon in the taskbar to assign all the roles in the current window to a user account or group. Alternatively, click the **Remove all Roles** icon to unassign all the roles associated with a user account or group.

- Step 6** Click **Submit**.
- The roles assigned to a user account or group will be listed in the Roles section in the Modifying User Account (or Modifying User Group) window.
-

Modifying and Deleting a Role

**Note**

The admin user account, by default, is allowed access to all the services, and cannot be modified.

To modify or delete a role, follow these steps:

-
- Step 1** From the WAAS Central Manager menu, choose **Admin > AAA > Roles**.
- The Roles window appears.
- Step 2** Click the **Edit** icon next to the name of the role you want to change or delete.
- The Modifying Role window appears. You can modify the role as follows:
- To delete this role, click the **Delete** icon in the taskbar.
 - To edit this role, make the necessary changes to the fields, and click **Submit**.

- To enable a service for this role, check the check box next to the corresponding service. To disable a previously selected service, uncheck the check box next to the service you want to disable. To choose all the services under one category simultaneously, check the check box next to the top-level service.
-

Viewing Role Settings

You might want to view role settings before assigning a role to a particular user account or group.

To view role settings, follow these steps:

-
- Step 1** From the WAAS Central Manager menu, choose **Admin > AAA > Users** (or **Admin > AAA > User Groups**).
- The User Accounts (or User Groups) window appears with all the configured user accounts or groups listed.
- Step 2** Click the **Edit** icon next to the user account or group that you want to view.
- The Modifying User Account (or Modifying User Group) window appears.
- Step 3** Click the **Role Management** tab.
- The Role Management window appears.
- Step 4** Click the **View** icon next to the role that you want to view.
- The Viewing Role window appears, which displays the role name, comments about this role, and the services that are enabled for this role.
- Step 5** After you have finished viewing the settings, click **Close**.
-

Working with Domains

A WAAS *domain* is a collection of device groups or WAEs that make up the WAAS network. A role defines which services a user can manage in the WAAS network, but a domain defines the device groups, WAEs, or file server dynamic shares that are accessible and configurable by the user.



Note

A WAAS domain is not the same as a DNS domain or Windows domain.

When you create a domain, you choose the type of entities that can be associated with the domain. Entity types include Devices, Device Groups, or None (for file server dynamic shares). For file server dynamic shares, the dynamic shares are assigned in the dynamic shares configuration.

WAAS can dynamically assign a domain to a user based on their membership in a group as defined on an external TACACS+ or Windows domain authentication server. To take advantage of this feature, you must define user group names on the WAAS Central Manager that match the user groups defined on the external authentication server and you must assign a domain to the user groups on the WAAS Central Manager. For more information on user groups, see [Working with User Groups](#).

This section contains the following topics:

- [Creating a New Domain](#)

- [Adding an Entity to a Domain](#)
- [Assigning a Domain to a User Account](#)
- [Modifying and Deleting a Domain](#)
- [Viewing Domains](#)

Creating a New Domain

To create a new domain, follow these steps:

-
- Step 1** From the WAAS Central Manager menu, choose **Admin > AAA > Domains**.
The Domains listing window appears.
- Step 2** Click the **Create New Domain** icon in the taskbar.
The Creating New Domain window appears.
- Step 3** In the Name field, enter the name of the domain.
- Step 4** From the Entity Type drop-down list, choose the entity type (Devices, Device Groups, or None) that you want to assign to the domain.



Note Choose **None** if this domain is used for a file server dynamic share.

- Step 5** (Optional) In the Comments field, enter comments, if any, about this domain.
- Step 6** Click **Submit**.
If the entity type you chose has not been assigned to the domain, then a message indicating that the entity type has not been assigned appears.
- Step 7** Assign an entity to this domain, as described in [Adding an Entity to a Domain](#). If you chose None for the Entity Type, do not assign an entity to the domain, instead, the entity is used in a dynamic share configuration.

For a domain used in a dynamic share configuration, assign the domain to each user having to edit the dynamic share configuration, as described in [Assigning a Domain to a User Account](#). Only users assigned to the domain will be able to edit the dynamic share configuration.

Adding an Entity to a Domain

After you have created a domain, you can assign an entity to the domain. An entity is either a collection of devices or a collection of device groups. You do not have to assign an entity to a domain that is used for a file server dynamic share, where the entity type is None.

To add an entity to a domain, follow these steps:

-
- Step 1** From the WAAS Central Manager menu, choose **Admin > AAA > Domains**.
- Step 2** Click the **Edit** icon next to the domain that you want to modify.
- Step 3** Click the **Entity Management** tab.
The *Entity_name* Assignments for Domain window for the current domain appears.

You can filter your view of the items in the list. Filtering enables you to find items matching the criteria that you set, in the list.

You can add or remove entities from the domain as follows:

- To add an entity to the current domain, click the **Assign** icon (blue cross mark) next to the entity that you want to add. A green tick mark appears next to the selected entity when you submit the settings. Alternatively, to add all the entities to the selected domain, click the **Assign all** icon in the taskbar.
- To remove an entity from the current domain, click the **Unassign** icon (green tick mark) next to the name of the entity that you want to remove from the domain. A blue cross mark appears next to the unassigned entity after you submit the settings.

Alternatively, to remove all the entities from the domain, click the **Remove all** icon in the taskbar.

Step 4 Click **Submit**.

Green check marks appear next to the entities that you assigned to the domain.

Step 5 Assign the domain to an account, as described in [Assigning a Domain to a User Account](#).

Assigning a Domain to a User Account

Assigning a domain to an account or user group specifies the entities (devices or device groups) or file server dynamic shares that the account or user group can access.

When working with a domain of type None that is used for dynamic file shares, you will need a user account for every user having to edit the dynamic share configuration. If you are using external authentication of users on TACACS+ or Windows domain servers, you can use user groups to more easily assign WAAS domains to users. For more information, see [Working with User Groups](#).



Note

If the role that you assigned to an account or group has the All Devices or All Device Groups service enabled, you do not have to assign a domain to the account or group. The account or group can automatically access all the devices or device groups, or both, in the WAAS system. For more information, see [Table 8-4](#).

To assign a domain to a user account or group, follow these steps:

Step 1 From the WAAS Central Manager menu, choose **Admin > AAA > Users** (or **Admin > AAA > User Groups**).

The User Accounts (or User Groups) window appears with all the configured user accounts or groups listed.

Step 2 Click the **Edit** icon next to the user account or group for which you want to assign domains.

The Modifying User Account (or Modifying User Group) window appears.

Step 3 Click the **Domain Management** tab.

The Domain Management window appears with all configured domains and their entity types listed.

Step 4 Click the **Assign** icon (blue cross mark) that appears next to the domain name that you want to assign to the selected user account or group.

To dissociate a domain from the user account or group, click the **Unassign** (green tick mark) next to the domain name.



Note To assign all the domains in the current window to a user account or group, click the **Assign all Domains** icon in the taskbar. Alternatively, to unassign all the domains associated with a user account or group, click the **Remove all Domains** icon.

Step 5 Click **Submit**.

The domains assigned to a user account or group are listed in the Domains section in the Modifying User Account (or Modifying User Group) window.

Modifying and Deleting a Domain

To modify or delete an existing domain, follow these steps:

Step 1 From the WAAS Central Manager menu, choose **Admin > AAA > Domains**.

The Domains window appears.

Step 2 Click the **Edit** icon next to the domain that you want to modify.

The Modifying Domain window appears. You can modify the domain as follows:

- To delete the domain, click the **Delete** icon in the taskbar and then click **OK** to confirm the deletion.
 - To modify a domain, make the necessary changes to the fields, and click **Submit**.
-

Viewing Domains

To view the domain configuration for a particular user account or group, follow these steps:

Step 1 From the WAAS Central Manager menu, choose **Admin > AAA > Users** (or **Admin > AAA > User Groups**).

The User Accounts (or User Groups) window appears with all the configured user accounts or groups listed.

Step 2 Click the **Edit** icon next to the user account or group for which you want to view the domain configuration.

The Modifying User Account (or Modifying User Group) window appears.

Step 3 Click the **Domain Management** tab.

The Domain Management window appears.

Step 4 Click the **View** (eyeglass) icon next to the domain name to view details about the domain.

The Viewing Domain window appears and displays the domain name, entity type, comments about this domain, and entities assigned to this domain.

Step 5 After you have finished viewing the settings, click **Close**.

Working with User Groups

If you are using external authentication of users on TACACS+ or Windows domain servers (not RADIUS servers), you may want to create user groups. By creating user group names that match the user groups that you have defined on the external authentication server, WAAS can dynamically assign roles and WAAS domains to users, based on their membership in a group as defined on the external authentication server. You do not have to define a role or WAAS domain for each user individually; instead, you define roles and WAAS domains for the user groups, and a user is assigned the roles and WAAS domains that are defined for the groups to which they belong.

**Note**

The dynamic assignment of roles and WAAS domains based on external user groups requires a TACACS+ server that supports shell custom attributes. For example, these are supported in Cisco ACS (Access Control Server) 4.x and 5.1 and later.

WAAS reads group membership information for each user from the external authentication server.

This section contains the following topics:

- [Creating a New User Group](#)
- [Assigning Roles to a User Group](#)
- [Assigning a Domain to a User Group](#)
- [Modifying and Deleting a User Group](#)
- [Viewing User Groups](#)

Creating a New User Group

To create a new user group, follow these steps:

-
- Step 1** From the WAAS Central Manager menu, choose **Admin > AAA > User Groups**.
The User Groups listing window appears.
- Step 2** Click the **Create New User Groups** icon in the taskbar.
The Creating New User Group window appears.
- Step 3** In the Name field, enter the name of the user group.
Ensure that the name matches the name of a user group defined on the external authentication server that you are using.
Name matching is case sensitive. A user group name cannot contain the following characters: # + " < > , (comma). A user group name cannot consist solely of numbers, periods (.), or spaces. Any leading periods, asterisks (*), or spaces are cropped.
- Step 4** (Optional) In the Comments field, enter comments, if any, about this user group.
- Step 5** Click **Submit**.
- Step 6** Assign a role or WAAS domain to this user group, as described in [Assigning Roles to a User Group](#) and [Assigning a Domain to a User Group](#).
-

Assigning Roles to a User Group

After you create a user group, you have to assign a role to the group. If you create a user group but do not assign a role to the group, the users in that group can log in to the WAAS Central Manager GUI, but no data will be displayed and the configuration pages will not be available.

To assign one or more roles to a user group, follow these steps:

-
- Step 1** From the WAAS Central Manager menu, choose **Admin > AAA > User Groups**.
The User Groups window appears with all the configured user groups listed.
- Step 2** Click the **Edit** icon next to the user group for which you want to assign roles.
The Modifying User Group window appears.
- Step 3** Click the **Role Management** tab.
The Role Management for User Group window appears with all the configured role names listed.
- Step 4** Click the **Assign** icon (blue cross mark) that appears next to the role name that you want to assign to the selected user group.
- Step 5** Click the **Unassign** (green tick mark) next to the role name to unassign a previously assigned user group role.



Note Click the **Assign all Roles** icon in the taskbar to assign all the roles in the current window to a user group. Alternatively, click the **Remove all Roles** icon to unassign all the roles associated with a user group.

- Step 6** Click **Submit**.
The roles assigned to a user group will be listed in the Roles section in the Modifying User Group window.
-

Assigning a Domain to a User Group

Assigning a WAAS domain to a user group specifies the entities (devices or device groups) that the users who are members of that user group can manage.



Note If the role that you assigned to a user group has the All Devices or All Device Groups service enabled, you do not have to assign a domain to the user group. The users in that group can automatically access all the devices, or device groups, or both, in the WAAS system. For more information, see [Table 8-4](#).

To assign a domain to a user group, follow these steps:

-
- Step 1** From the WAAS Central Manager menu, choose **Admin > AAA > User Groups**.
The User Groups window appears with all the configured user groups listed.
- Step 2** Click the **Edit** icon next to the user group for which you want to assign domains.
The Modifying User Group window appears.
- Step 3** Choose the **Domain Management** tab.

The Domain Management for User Group window appears with all the configured domains and their entity types listed.

Step 4 Click the **Assign** icon (blue cross mark) that appears next to the domain name that you want to assign to the selected user group.

To dissociate a domain from the user group, click the **Unassign** (green tick mark) next to the domain name.



Note To assign all the domains in the current window to a user group, click the **Assign all Domains** icon in the taskbar. Alternatively, to unassign all the domains associated with a user group, click the **Remove all Domains** icon.

Step 5 Click **Submit**.

The domains assigned to a user group are listed in the Domains section in the Modifying User Group window.

Modifying and Deleting a User Group

To modify an existing user group, follow these steps:

Step 1 From the WAAS Central Manager menu, choose **Admin > AAA > User Groups**.

The User Groups window appears.

Step 2 Click the **Edit** icon next to the user group that you want to modify.

The Modifying User Group window appears. You can delete or edit user groups as follows:



Note This window can be accessed only by users with administrator-level privileges.

- To delete the user group, click the **Delete** icon in the taskbar, and then click **OK** to confirm the deletion.
- To edit the user group, make the necessary changes to the name and comment information, and click **Submit**.
- To change the roles assigned to the user group, click the **Role Management** tab, make the necessary changes to the roles, and click **Submit**.
- To change the domains assigned to the user group, click the **Domain Management** tab, make the necessary changes to the domains, and click **Submit**.

Viewing User Groups

To view all the user groups, choose **Admin > AAA > User Groups** from the WAAS Central Manager GUI. The User Groups window displays all the user groups in the management database. From this window, you can also create groups, as described in [Creating a New User Group](#).



Creating and Managing IP Access Control Lists for Cisco WAAS Devices

This chapter describes how to use the Cisco Wide Area Application Services (Cisco WAAS) Central Manager GUI to centrally create and manage IP access control lists (ACLs) for your Cisco WAAS devices.

This chapter contains the following sections:

- [Overview of IP ACLs for WAAS Devices](#)
- [Creating and Managing IP ACLs for WAAS Devices](#)
- [List of Extended IP ACL Conditions](#)



Note

You must log in to the WAAS Central Manager GUI using an account with admin privileges to view, edit, or create IP ACL configurations.



Note

Throughout this chapter, the term Cisco WAAS device is used to refer collectively to the WAAS Central Managers and Cisco Wide Area Application Engines (Cisco WAEs) in your network. The term WAE refers to WAE appliances, WAE Network Modules (the Cisco NME-WAE family of devices), and Cisco SRE service modules (SM) running WAAS.

Overview of IP ACLs for WAAS Devices

In a centrally managed WAAS network environment, administrators should be able to prevent unauthorized access to various devices and services. IP ACLs can filter packets by allowing you to permit or deny IP packets destined for a WAAS device.

The WAAS software supports standard and extended ACLs that allow you to restrict access to a WAAS device. The WAAS software can use the following types of ACLs:

- **Interface ACL**—Applied on the built-in, port channel, standby, and inline group interfaces. This type of ACL is intended to control management traffic (Telnet, SSH, and Central Manager GUI). The ACL rules apply only to traffic that is destined for the WAE or originates from the WAE, not Web Cache Communication Protocol (WCCP) transit traffic. Use the **ip access-group** interface configuration command to apply an interface ACL.

- **Interception ACL**—Applied globally to a WAAS device. This type of ACL defines what traffic is to be intercepted. Traffic that is permitted by the ACL is intercepted and traffic that is denied by the ACL is passed through the WAE. Use the **interception access-list** global configuration command to apply an interception ACL. For more information on using interception ACLs, see [Configuring Interception Access Control Lists](#) in Chapter 5, “Configuring Traffic Interception.”
- **WCCP ACL**—Applied on inbound WCCP-redirection traffic to control access between an external server and external clients. The WAE acts like a firewall. Use the **wccp access-list** global configuration command to apply a WCCP ACL.
- **SNMP ACL**—Applied on an SNMP agent to control access to the SNMP agent by an external SNMP server that is polling for SNMP MIBs or SNMP statistics. Use the **snmp-server access-list** global configuration command to apply an SNMP ACL.
- **Transaction-logs-flow ACL**—Applied on the transaction logging facility to restrict the transactions to be logged. Use the **transaction-logs flow access-list** global configuration command to apply a transaction log ACL.

The following examples illustrate how interface ACLs can be used in environments that have WAAS devices:

- A WAAS device resides on the customer premises and is managed by a service provider, and the service provider wants to secure the device for its management only.
- A WAAS device is deployed anywhere within the enterprise. As with routers and switches, the administrator wants to limit access to Telnet, SSH, and the WAAS Central Manager GUI to the IT source subnets.

To use ACLs, you must first configure ACLs and then apply them to specific services or interfaces on the WAAS device. The following are some examples of how interface ACLs can be used in various enterprise deployments:

- An application layer proxy firewall with a hardened outside interface has no ports exposed. (*Hardened* means that the interface carefully restricts which ports are available for access, primarily for security reasons. Because the interface is outside, many types of attacks are possible.) The WAAS device’s outside address is globally accessible from the Internet, while its inside address is private. The inside interface has an ACL to limit Telnet, SSH, and GUI access.
- A WAE that is using WCCP is positioned on a subnet off the Internet router. Both the WAE and the router must have IP ACLs. IP access lists on routers have the highest priority, followed by IP ACLs that are defined on the WAEs.



Note

We strongly recommend that you use the WAAS Central Manager GUI instead of the WAAS CLI to centrally configure and apply ACLs to your WAAS devices. For more information, see the [Creating and Managing IP ACLs for WAAS Devices](#).

Creating and Managing IP ACLs for WAAS Devices

This section provides guidelines and an example of how to use the WAAS Central Manager GUI to create and manage IP ACLs for your WAAS devices.

When you create an IP ACL, you should note the following important points:

- IP ACL names must be unique within the device.
- IP ACL names must be limited to 30 characters and contain no white space or special characters.

- Each WAAS Central Manager device can manage up to 50 IP ACLs and a total of 500 conditions per device.
- When the IP ACL name is numeric, numbers 1 through 99 denote standard IP ACLs and numbers 100 through 199 denote extended IP ACLs. IP ACL names that begin with a number cannot contain nonnumeric characters.
- The WAAS Central Manager GUI allows the association of standard IP ACLs with SNMP and WCCP. Any device that attempts to access one of these applications associated with an ACL must be on the list of trusted devices to be allowed access.
- You can associate any previously configured standard IP ACL with SNMP and WCCP. However, you can associate an extended IP ACL only with the WCCP application.
- You can delete an IP ACL, including all conditions and associations with network interfaces and applications, or you can delete only the IP ACL conditions. Deleting all conditions allows you to change the IP ACL type if you choose to do so. The IP ACL entry continues to appear in the IP ACL listing. However, it is, in effect, nonexistent.
- If you specify an empty ACL for any of the ACL types used by WAAS, it permits all traffic.

To use the WAAS Central Manager GUI to create and modify an IP ACL for a single WAE, associate an IP ACL with an application, and then apply it to an interface on the WAE, follow these steps:

Step 1 From the WAAS Central Manager menu, choose **Devices** > *device-name*.

Step 2 Choose **Configure** > **Network** > **TCP/IP Settings** > **IP ACL**.

The IP ACL window appears. By default, there are no IP ACLs defined for a WAE. The IP ACL window indicates if there are currently no IP ACLs configured for the WAE.

Step 3 Click **Add IP ACL** on the table heading row.

The **IP ACL** window appears. Fill in the fields as follows:

- In the Name field, enter a name, for example, test1. IP ACL names must be unique within the device, must be limited to 30 characters, and cannot contain any white spaces or special characters.
By default, this new IP ACL is created as a standard ACL.
- To change this default setting and create this new ACL as an extended ACL, choose **Extended** from the ACL Type drop-down list.

Step 4 Click **OK** to save the IP ACL named test1. IP ACLs without any conditions defined do not appear on the individual devices.

Step 5 Add conditions to the standard IP ACL named test1 that you just created:

- a. Click the **Add IP ACL Condition**.

The IP ACL Condition window appears (Figure 9-1).



Note

The number of available fields for creating IP ACL conditions depends on the type of IP ACL that you have created, either standard or extended.

Figure 9-1 Creating a New Condition for an Extended IP ACL Window

IP ACL Condition

General

Purpose: *

Extended Type: *

Protocol:

Source

Source IP: *

Source IP Wildcard: *

Destination

Destination IP:

Destination IP Wildcard:

344227

- b. Enter values for the properties that are enabled for the type of IP ACL that you are creating, as follows:
 - To set up conditions for a standard IP ACL, go to [Step 6](#).
 - To set up conditions for an extended IP ACL, go to [Step 7](#).

Step 6 Set up conditions for a standard IP ACL:

- a. From the Purpose drop-down list, choose a purpose (**Permit** or **Deny**).
- b. In the Source IP field, enter the source IP address.
- c. In the Source IP Wildcard field, enter a source IP wildcard address.
- d. Click **OK** to save the condition.

IP ACL conditions for the newly created IP ACL and its configured parameters are displayed in [Table 9-1](#).
- e. To add another condition to the IP ACL, select it and click **Add IP ACL Condition**.
- f. Enter the details of the condition and click **OK** to save the additional condition.
- g. For a newly created IP ACL condition to appear in a particular position, select the position and click **Insert**. The IP ACL condition is placed in the selected position.
- h. To rearrange your list of conditions, select the condition (or multiple consecutive conditions) and use the Up or Down arrows, and click **Save Moved Rows** to commit the changes.

Alternatively, you can select one or multiple consecutive conditions and click **Move to**, to specify the row number in which the IP ACL condition should be positioned. This is especially helpful when there are numerous conditions listed in the table. After you are satisfied with all your entries and the order in which the conditions are listed, click **Save Moved Rows** to commit the changes.



Note The order of the conditions listed in the WAAS Central Manager GUI becomes the order in which IP ACLs are applied to the device.



Note Click a column heading to sort by a configured parameter.

Table 9-1 describes the fields in a standard IP ACL.

Table 9-1 Standard IP ACL Conditions

Field	Default Value	Description
Purpose	Permit	Specifies whether a packet is to be passed (Permit) or dropped (Deny).
Source IP	0.0.0.0	Number of the network or host from which the packet is being sent, specified as a 32-bit quantity in 4-part dotted decimal format.
Source IP Wildcard	255.255.255.255	Wildcard bits to be applied to the source, specified as a 32-bit quantity in 4-part dotted decimal format. Place a 1 in the bit positions that you want to ignore and identify bits of interest with a 0.

Step 7 Set up conditions for an extended IP ACL:

- a. From the Purpose drop-down list, choose a purpose (**Permit** or **Deny**).
- b. From the Extended Type drop-down list, choose a value (**Generic**, **TCP**, **UDP**, or **ICMP**). (See Table 9-2.)

Table 9-2 Extended IP ACL Conditions

Field	Default Value	Description
Purpose	Permit	Specifies whether a packet is to be passed or dropped. Choices are Permit or Deny.
Extended Type	Generic	Specifies the Internet protocol to be applied to the condition. When selected, the GUI window refreshes with applicable field options enabled. The options are generic, TCP, UDP, or ICMP.

After you choose a type of extended IP ACL, various options become available in the GUI, depending on what type you choose.

- c. In the fields that are enabled for the chosen type, enter the data. (For more information, see Table 9-4 through Table 9-7.)
- d. Click **OK** to save the condition.
IP ACL conditions for the newly created IP ACL and its configured parameters are displayed in Table 9-1.
- e. To add another condition to the IP ACL, select it and click **Add IP ACL Condition**.
- f. Enter the details of the condition in the window and click **OK** to save the additional condition.
- g. For a newly created IP ACL condition to appear in a particular position, select the position and click **Insert**. The IP ACL condition is placed in the selected position.
- h. To rearrange your list of conditions, select the condition (or multiple consecutive conditions) and use the Up or Down arrows. Click **Save Moved Rows** to commit the changes.
Alternatively, you can select one or multiple consecutive conditions and click **Move to**, to specify

the row number in which the IP ACL condition should be positioned. This is especially helpful when there are numerous conditions listed in the table. After you are satisfied with all your entries and the order in which the conditions are listed, click **Save Moved Rows** to commit the changes.



Note The order of the conditions listed in the WAAS Central Manager GUI becomes the order in which IP ACLs are applied to the device.



Note Click a column heading to sort by any configured parameter.

- Step 8** Modify or delete an individual condition from an IP ACL:
- Select the name of the IP ACL whose condition you want to modify.
 - A list of all the conditions that are currently applied to the IP ACL appears in the IP ACL Conditions, [Table 9-1](#). Select the condition and click **Edit**.
 - To modify the condition, change any corresponding field as necessary in the IP ACL Condition window and click **OK** to save the modifications.
 - To delete the condition, select it and click **Delete** on the table header.
 - To rearrange your list of conditions, use the Up or Down arrows or the **Move to** column outlined in [Step 6f](#) and [7f](#).

- Step 9** Associate a standard IP ACL with SNMP or WCCP:
- Click the **Edit** icon next to the name of the device for which you want to associate a standard IP ACL with SNMP or WCCP.
 - Choose **Configure > Network > TCP/IP Settings > IP ACL Feature Usage**.
The IP ACL Feature Settings window appears.
 - From the SNMP or WCCP drop-down lists, choose the name of an IP ACL for SNMP or WCCP. (For more details, see [Table 9-3](#).) If you do not want to associate an IP ACL with one of the applications, choose **Do Not Set**.

Table 9-3 IP ACL Feature Settings

Cisco WAAS Central Manager GUI Parameter	Function
SNMP	Associates a standard IP ACL with SNMP. This option is supported for all WAAS devices.
WCCP	Associates any of the IP ACLs with WCCP Version 2. This option is supported only for WAAS devices that are operating in WCCP interception mode and not for WAAS Central Manager devices.

- Click **Submit** to save the settings.

- Step 10** Apply an IP ACL to an interface:
- Click the **Edit** icon next to the name of the device for which you want to apply an IP ACL to an interface on the WAE.
 - Choose **Configure > Network > Network Interfaces**.

The Network Interfaces window for the device appears. This window displays all the interfaces available on that device.

- c. Click the **Edit** icon next to the name of the interface to which you want to apply an IP ACL. The Network Interface settings window appears.
- d. From the Inbound ACL drop-down list at the bottom of the window, choose the name of an IP ACL.
- e. From the Outbound ACL drop-down list, choose the name of an ACL.

The only network interface properties that can be altered from the WAAS Central Manager GUI are the inbound and outbound IP ACLs. All other property values are populated from the device database and are read-only in the WAAS Central Manager GUI.

- Step 11** Click **Submit** to save the settings.
- Step 12** To use an IP ACL to define the traffic that should be intercepted, see the [Configuring Interception Access Control Lists](#) in Chapter 5, “Configuring Traffic Interception.”
- Step 13** (Optional) Delete an IP ACL:
- a. Click the **Edit** icon next to the name of the device that has the IP ACL that you want to delete.
 - b. Choose **Configure > Network > TCP/IP Settings > IP ACL**.
If you created conditions for the IP ACL, you have two options for deletion:
 - **Delete ACL**—Removes the IP ACL, including all the conditions and associations with network interfaces and applications.
 - **Delete All Conditions**—Removes all the conditions, while preserving the IP ACL name.
 - c. To delete the entire IP ACL and its conditions, select the corresponding IP ACL and click **Delete**. You are prompted to confirm your action. Click **OK**. The record is deleted.
 - d. To delete only the conditions, select the condition or multiple conditions (consecutive or nonconsecutive conditions) and click **Delete**. When you are prompted to confirm your action, click **OK**. The conditions are deleted.

To define an IP ACL from the CLI, you can use the **ip access-list** global configuration command, and to apply the IP ACL to an interface on the WAAS device, you can use the **ip access-group** interface configuration command. To configure the use of an IP ACL for SNMP, you can use the **snmp-server access-list** global configuration command. To specify an IP ACL that the WAE applies to the inbound WCCP redirected traffic that it receives, you can use the **wccp access-list** global configuration command. To configure an interception ACL, you can use the **interception access-list** global configuration command.

List of Extended IP ACL Conditions

When you define a condition for an extended IP ACL, you can specify the Internet protocol to be applied to the condition (as described in [Step 7](#) in the [Creating and Managing IP ACLs for WAAS Devices](#)).

The list of extended IP ACL conditions are as follows:

- Generic ([Table 9-4](#))
- TCP ([Table 9-5](#))
- UDP ([Table 9-6](#))

- ICMP (Table 9-7)

Table 9-4 Extended IP ACL Generic Conditions

Field	Default Value	Description
Purpose	Permit	Specifies whether a packet is to be passed (Permit) or dropped (Deny).
Extended Type	Generic	Matches any IP.
Protocol	ip	IP (gre , icmp , ip , tcp , or udp). To match any IP, use the keyword ip .
Source IP ¹	0.0.0.0	Number of the network or host from which the packet is being sent, specified as a 32-bit quantity in 4-part dotted decimal format.
Source IP Wildcard ¹	255.255.255.255	Wildcard bits to be applied to the source, specified as a 32-bit quantity in 4-part dotted decimal format. Place a 1 in the bit positions that you want to ignore and identify bits of interest with a 0.
Destination IP	0.0.0.0	Number of the network or host to which the packet is being sent, specified as a 32-bit quantity in 4-part dotted decimal format.
Destination IP Wildcard	255.255.255.255	Wildcard bits to be applied to the source, specified as a 32-bit quantity in 4-part dotted decimal format. Place a 1 in the bit positions that you want to ignore and identify bits of interest with a 0.

Table 9-5 Extended IP ACL TCP Conditions

Field	Default Value	Description
Purpose	Permit	Specifies whether a packet is to be passed (Permit) or dropped (Deny).
Extended Type	TCP	Matches the TCP IP.
Established	Unchecked (false)	When checked, a match with the ACL condition occurs if the TCP datagram has the ACK or RST bits set, indicating an established connection. Initial TCP datagrams used to form a connection are not matched.
Source IP	0.0.0.0	Number of the network or host from which the packet is being sent, specified as a 32-bit quantity in 4-part dotted decimal format.
Source IP Wildcard	255.255.255.255	Wildcard bits to be applied to the source, specified as a 32-bit quantity in 4-part dotted decimal format. Place a 1 in the bit positions that you want to ignore and identify bits of interest with a 0.
Source Port 1	0	Decimal number or name of a TCP port. Valid port numbers are 0 to 65535. Valid TCP port names are as follows: ftp , ftp-data , https , mms , netbios-dgm , netbios-ns , netbios-ss , nfs , rtsp , ssh , telnet , and www .

Table 9-5 *Extended IP ACL TCP Conditions (continued)*

Field	Default Value	Description
Source Operator	range	Specifies how to compare the source ports against incoming packets. Choices are <, >, ==, !=, or range.
Source Port 2	65535	Decimal number or name of a TCP port. See Source Port 1, in this table.
Destination IP	0.0.0.0	Number of the network or host to which the packet is being sent, specified as a 32-bit quantity in 4-part dotted decimal format.
Destination IP Wildcard	255.255.255.255	Wildcard bits to be applied to the source, specified as a 32-bit quantity in 4-part dotted decimal format. Place a 1 in the bit positions that you want to ignore and identify bits of interest with a 0.
Destination Port 1	0	Decimal number or name of a TCP port. Valid port numbers are 0-65535. Valid TCP port names are as follows: ftp , ftp-data , https , mms , netbios-dgm , netbios-ns , netbios-ss , nfs , rtsp , ssh , telnet , and www .
Destination Operator	range	Specifies how to compare the destination ports against incoming packets. Choices are <, >, ==, !=, or range.
Destination Port 2	65535	Decimal number or name of a TCP port. See Destination Port 1, in this table.

Table 9-6 *Extended IP ACL UDP Conditions*

Field	Default Value	Description
Purpose	Permit	Specifies whether a packet is to be passed (Permit) or dropped (Deny).
Extended Type	UDP	Matches the UDP IP.
Established	—	Not available for UDP.
Source IP	0.0.0.0	Number of the network or host from which the packet is being sent, specified as a 32-bit quantity in 4-part dotted decimal format.
Source IP Wildcard	255.255.255.255	Wildcard bits to be applied to the source, specified as a 32-bit quantity in 4-part dotted decimal format. Place a 1 in the bit positions that you want to ignore and identify bits of interest with a 0.
Source Port 1	0	Decimal number or name of a UDP port. Valid port numbers are 0-65535. Valid UDP port names are as follows: bootpc , bootps , domain , mms , netbios-dgm , netbios-ns , netbios-ss , nfs , ntp , snmp , snmptrap , tacacs , tftp , and wccp .
Source Operator	range	Specifies how to compare the source ports against incoming packets. Choices are <, >, ==, !=, or range.
Source Port 2	65535	Decimal number or name of a UDP port. See Source Port 1, in this table.

Table 9-6 *Extended IP ACL UDP Conditions (continued)*

Field	Default Value	Description
Destination IP	0.0.0.0	Number of the network or host to which the packet is being sent, specified as a 32-bit quantity in 4-part dotted decimal format.
Destination IP Wildcard	255.255.255.255	Wildcard bits to be applied to the source, specified as a 32-bit quantity in 4-part dotted decimal format. Place a 1 in the bit positions that you want to ignore and identify bits of interest with a 0.
Destination Port 1	0	Decimal number or name of a UDP port. Valid port numbers are 0-65535. Valid UDP port names are as follows: bootpc , bootps , domain , mms , netbios-dgm , netbios-ns , netbios-ss , nfs , ntp , snmp , snmptrap , tacacs , tftp , and wccp .
Destination Operator	range	Specifies how to compare the destination ports against incoming packets. Choices are <, >, ==, !=, or range.
Destination Port 2	65535	Decimal number or name of a UDP port. See Destination Port 1, in this table.

Table 9-7 *Extended IP ACL ICMP Conditions*

Field	Default Value	Description
Purpose	Permit	Specifies whether a packet is to be passed (Permit) or dropped (Deny).
Extended Type	ICMP	Matches the ICMP IP.
Source IP	0.0.0.0	Number of the network or host from which the packet is being sent, specified as a 32-bit quantity in 4-part dotted decimal format.
Source IP Wildcard	255.255.255.255	Wildcard bits to be applied to the source, specified as a 32-bit quantity in 4-part dotted decimal format. Place a 1 in the bit positions that you want to ignore and identify bits of interest with a 0.
Destination IP	0.0.0.0	Number of the network or host to which the packet is being sent, specified as a 32-bit quantity in 4-part dotted decimal format.
Destination IP Wildcard	255.255.255.255	Wildcard bits to be applied to the source, specified as a 32-bit quantity in 4-part dotted decimal format. Place a 1 in the bit positions that you want to ignore and identify bits of interest with a 0.

Table 9-7 *Extended IP ACL ICMP Conditions (continued)*

Field	Default Value	Description
ICMP Param Type	None	The ICMP parameter choices are None , Type/Code , or Msg . <ul style="list-style-type: none"> • None—Disables the ICMP Type, Code, and Message fields. • Type/Code—Allows ICMP messages to be filtered by ICMP message type and code. Also enables the ability to set an ICMP message code number. • Msg—Allows a combination of type and code to be specified using a keyword. Activates the ICMP message drop-down list. Disables the ICMP Type field.
ICMP Message	administratively-prohibited	Allows a combination of ICMP type and code to be specified using a keyword chosen from the drop-down list.
ICMP Type	0	Number from 0-255. This field is enabled when you choose Type/Code .
Use ICMP Code	Unchecked	When checked, enables the ICMP Code field.
ICMP Code	0	Number from 0-255. Message code option that allows ICMP messages of a particular type to be further filtered by an ICMP message code.



Configuring Other System Settings

This chapter describes how to perform other system tasks such as setting the system clock, modifying the default system configuration settings, and enabling alarm overload detection, after you have done a basic configuration of your WAAS device. This chapter also describes how to register and manage Cisco IOS routers running AppNav-XE and WAAS Express.



Note

Throughout this chapter, the term WAAS device is used to refer collectively to the WAAS Central Managers and WAEs in your network. The term WAE refers to WAE and WAVE appliances, SM-SRE modules running WAAS, and vWAAS instances.

This chapter contains the following sections:

- [Modifying Device Properties](#)
- [Managing Software Licenses](#)
- [Enabling FTP Services](#)
- [Configuring Date and Time Settings](#)
- [Configuring Secure Store Settings](#)
- [Modifying the Default System Configuration Properties](#)
- [Configuring the Web Application Filter](#)
- [Configuring Faster Detection of Offline WAAS Devices](#)
- [Configuring Alarm Overload Detection](#)
- [Configuring the E-mail Notification Server](#)
- [Using IPMI over LAN](#)
- [Managing Cisco IOS Router Devices](#)
- [WAAS, ISR-WAAS, and IOS-XE Interoperability](#)
- [Configuring the Hostname for ISR-WAAS](#)

Modifying Device Properties

The WAAS Central Manager GUI allows you to make the following changes to the properties of a WAE device:

- Rename the device

- Assign a new location to the device
- Assign an IP address to be used for management traffic to the device
- Deactivate or activate the device

You can also use the WAAS Central Manager GUI to check the status of a device to determine if it is online, pending, or inactive.

You can only rename a WAAS Central Manager device from the GUI.

To modify a device's properties, follow these steps:

Step 1 From the WAAS Central Manager menu, choose **Devices** > *device-name*.

Step 2 Choose *device-name* > **Activation**.

The Device Activation window appears with fields for editing the properties of the selected device.

For a WAAS Central Manager device, the only fields that you can change in this window are the name and NetBIOS name of the device. In addition, the device IP address and role are displayed.

Step 3 Under the General Configuration heading, set or modify the following device properties:

- To change the hostname of the device, enter a new name in the Name field. This name must conform to the following rules:
 - The name must use only alphanumeric characters and hyphens (-).
 - The first and last character must be a letter or a digit.
 - Maximum length is 30 characters.
 - Names are case insensitive.
 - The following characters are considered illegal and cannot be used when naming a device: @, #, \$, %, ^, &, *, (), |, \\'"/, <>.

- To activate or deactivate the device, check or uncheck the **Activate** check box. When this box is checked, the device is activated for centralized management through the WAAS Central Manager GUI.

You can also click the **Deactivate** icon in the task bar to deactivate the device. Deactivating a device allows you to replace the device in the event of a hardware failure without losing all of its configuration settings.

- To change the NetBIOS name of the device, enter the new NetBIOS name for the device in the provided field. The NetBIOS name must not consist of only numbers; it must include some letters. This field is not displayed for WAAS Express devices.

Step 4 Under the Locality heading, set or change the location by choosing a new location from the **Location** drop-down list. To create a location for this device, see [Creating Locations](#) in Chapter 3, "Using Device Groups and Device Locations."

Step 5 Under the Management Interface Configuration with NAT heading, configure the NAT settings using the following fields:

- Check the **Use WAE's primary IP Address** check box to enable the WAAS Central Manager to use the IP address configured on the primary interface of the device to communicate with devices in the WAAS network that are behind a NAT firewall. This check box is not displayed for WAAS Express devices.
- Allow the WAAS Central Manager to communicate with devices in the WAAS network that are behind the NAT firewall using an explicitly configured IP address, by entering the IP address of the device in the Management IP field. You also need to enter this address in scenarios where the

primary interface for a WAE is set to an inline group interface and management traffic is configured on a separate IP address (either on a secondary IP address on the same inline group interface or on a built-in interface).

- In the Port field, enter the port number for the management IP address. If the HTTPS server configured on a WAAS Express device is using a different port than the default of 443, configure the same port here.



Note If the WAAS Central Manager cannot contact a device using the primary IP address, it attempts to communicate using the Management IP address.

Step 6 In the Comments field, enter any comments that you want to appear for this device.

Step 7 Click **Submit**.

Managing Software Licenses

WAAS software version 4.1.1 introduces software licenses that enable specific WAAS optimization and acceleration features. A software license must be installed and configured before the features that it enables will operate.

[Table 10-1](#) lists the software licenses that may be purchased and the features that each license enables.

Table 10-1 WAAS Software Licenses

License	Description
Transport	Enables basic DRE, TFO, and LZ optimization. Cannot be configured if the Enterprise license is configured.
Enterprise	Enables the EPM, HTTP, MAPI, NFS, SSL, SMB, ICA, and Windows Print application accelerators, the WAAS Central Manager, and basic DRE, TFO, and LZ optimization. Cannot be configured if the Transport license is configured.

Licenses are installed and managed only on individual WAE devices, not device groups. Not all licenses are supported on all devices. A WAAS Central Manager device requires only the Enterprise license and no other licenses can be configured.



Note WAAS Express licenses cannot be managed via the WAAS Central Manager, as WAAS Express devices do not use the same kind of licenses as WAAS devices. WAAS Express licenses are managed via the router CLI only.

The exact WAAS Express licensing process depends on the version of IOS running on your WAAS Express router:

Prior to IOS 15.3(3), the WAAS Express license is managed by using the router CLI command **license install**. They use a single license that enables the WAAS Express optimization feature.

As of IOS 15.3(3)M the WAAS Express feature no longer requires a separate license, but is a Right To Use (RTU) feature included in the AppxK9 license.

As of IOS 15.4(1)T WAAS Express is a Right To Use (RTU) feature that is included in the default license coming with the router and no specific license needs to be installed anymore.

Regardless of the actual OS release used, the WAAS Express feature license must be purchased.

**Note**

If you are upgrading the WAAS Express devices to IOS 15.3(3)M version, as part of the new Appxk9 license support in WAAS Express IOS 15.3(3)M, you need to upgrade the WAAS Central Manager to 5.3.1 OR later. Else the devices go offline.

To add a license to a WAE from the WAAS Central Manager, follow these steps:

-
- Step 1** From the WAAS Central Manager menu, choose **Devices** > *device-name*. (Do not choose a Central Manager device because you must use the CLI to manage licenses on Central Managers.)
 - Step 2** Choose **Admin** > **History** > **License Management**.
 - Step 3** Check the check box next to each license that you want to add.
 - Step 4** Click **Submit**.
-

To add licenses from the CLI, you can use the **license add EXEC** command.

To remove licenses from the CLI, you can use the **clear license EXEC** command.

To display the status of all licenses from the CLI, you can use the **show license EXEC** command.

The setup utility also configures licenses when you first set up a new WAAS device.

Enabling FTP Services

File Transfer Protocol(FTP) lets you download, upload, and copy configuration files between remote hosts and a switch. Unlike TFTP, which uses User Datagram Protocol (UDP), a connectionless protocol, FTP uses TCP, which is connection oriented. Inetd (an Internet daemon) is a program that listens for connection requests or messages for certain ports and starts server programs to perform the services associated with those ports. FTP copies files between devices.

FTP is a subset of the UNIX rshell service, which allows UNIX users to execute shell commands on remote UNIX systems. It is a UNIX built-in service. This service uses TCP as the transport protocol and listens for requests on TCP port 514. FTP service can be enabled on WAAS devices that use WAAS software.

To enable FTP services on a WAAS device, follow these steps:

-
- Step 1** From the WAAS Central Manager menu, choose **Devices** > *device-name* (or **Device Groups** > *device-group-name*).
 - Step 2** Choose **Configure** > **Network** > **Network Services**. The Network Services window appears.
 - Step 3** Check the **Enable FTP** check box to enable Inetd FTP services. By default, this option is disabled.

**Note**

The Inetd daemon listens for FTP and TFTP services. For Inetd to listen to FTP requests, it must be explicitly enabled for FTP service.

- Step 4** Click **Submit** to save your changes.

A “Click Submit to Save” message appears in red next to the Current Settings line when there are pending changes to be saved after you have applied default or device group settings. You can also revert to the previously configured settings by clicking the Reset button. The Reset button is visible only when you have applied default or group settings to change the current device settings but you have not yet submitted the changes.

If you try to leave this window without saving the modified settings, a warning dialog box prompts you to submit the changes. This dialog box only appears if you are using the Internet Explorer browser.

Configuring Date and Time Settings

This section explains how to configure date and time settings for your WAAS network devices and contains the following topics:

- [Configuring NTP Settings](#)
- [Configuring Time Zone Settings](#)

Configuring NTP Settings

The WAAS Central Manager GUI allows you to configure the time and date settings using a Network Time Protocol (NTP) host on your network. NTP allows the synchronization of time and date settings for the different geographical locations of the devices in your WAAS network, which is important for proper system operation and monitoring. On each WAAS device, be sure to set up an NTP server to keep the clocks synchronized.

To configure NTP settings, follow these steps:

-
- Step 1** From the WAAS Central Manager menu, choose **Devices** > *device-name* (or **Device Groups** > *device-group-name*).
 - Step 2** Choose **Configure** > **Date/Time** > **NTP**. The NTP Settings window appears.
 - Step 3** In the NTP Server field, enter up to four hostnames or IP addresses, separated by spaces. This field now accepts IPv6 addresses.
 - Step 4** Click **Submit**.
-

Unexpected time changes can result in unexpected system behavior. We recommend reloading the system after configuring an NTP server or changing the system clock.

Configuring Time Zone Settings

If you have an outside source on your network that provides time services (such as a Network Time Protocol [NTP] server), you do not need to set the system clock manually. When manually setting the clock, enter the local time.

**Note**

Two clocks exist in the system: the software clock and the hardware clock. The software uses the software clock. The hardware clock is used only at startup to initialize the software clock.

To configure the time zone on a device or device group, follow these steps:

-
- Step 1** From the WAAS Central Manager menu, choose **Devices** > *device-name* (or **Device Groups** > *device-group-name*).
- Step 2** Choose **Configure** > **Date/Time** > **Time Zone**. The Time Zone Settings window appears.
- Step 3** To configure a standard time zone, follow these steps:
- Under the Time Zone Settings section, click the **Standard Time Zone** radio button. The default is UTC (offset = 0) with no summer time configured. When you configure a standard time zone, the system is automatically adjusted for the UTC offset, and the UTC offset need not be specified.
The standard convention for time zones uses a *Location/Area* format in which *Location* is a continent or a geographic region of the world and *Area* is a time zone region within that location.
 - From the drop-down list, choose a location for the time zone. (For an explanation of the abbreviations in this list, see [Table 10-2](#).)
The window refreshes, displaying all area time zones for the chosen location in the second drop-down list.
 - Choose an area for the time zone. The UTC offset is automatically set for standard time zones.
Summer time is built-in for some standard time zones (mostly time zones within the United States), and will result an automatic change in the UTC offset during summer time. For a list of standard time zones that can be configured and their UTC offsets, see [Table 10-3](#).
- Step 4** To configure a customized time zone on the device, follow these steps:
- Under the Time Zone Settings section, click the **Customized Time Zone** radio button.
 - In the Customized Time Zone field, specify the name of the time zone. The time zone entry is case-sensitive and can contain up to 40 characters including spaces. If you specify any of the standard time zone names, an error message is displayed when you click **Submit**.
 - For UTC Offset, choose the + or – sign from the first drop-down list to specify whether the configured time zone is ahead or behind UTC. Also, choose the number of hours (0–23) and minutes (0–59) offset from UTC for the customized time zone. The range for the UTC offset is from –23:59 to 23:59, and the default is 0:0.
- Step 5** To configure customized summer time, follow these steps under the Customized Summer Time Savings section.

**Note**

You can specify a customized summer time for both standard and customized time zones.

- To configure absolute summer time, click the **Absolute Dates** radio button.
You can configure a start date and end date for summer time in absolute dates or recurring dates. Absolute date settings apply only once and must be set every year. Recurring dates apply repeatedly for many years.
- In the Start Date and End Date fields, specify the month (January through December), day (1–31), and year (1993–2032) on which summer time must start and end in mm/dd/yyyy format. Make sure that the end date is always later than the start date.

Alternatively, click the **Calendar** icon next to the Start Date and End Date fields to display the Date Time Picker popup window. By default the current date is highlighted in yellow. In the Date Time Picker popup window, use the left or right arrow icons to choose the previous or following years, if required. Choose a month from the drop-down list. Click a day of the month. The chosen date is highlighted in blue. Click **Apply**. Alternatively, click **Set Today** to revert to the current day. The chosen date will be displayed in the Start Date and End Date fields.

- c. To configure recurring summer time, click the **Recurring Dates** radio button.
- d. From the Start Day drop-down list, choose a day of the week (**Monday–Sunday**) to start.
- e. From the Start Week drop-down list, choose an option (**first, 2nd, 3rd, or last**) to set the starting week. For example, choose **first** to configure summer time to recur beginning the first week of the month or **last** to configure summer time to recur beginning the last week of the month.
- f. From the Start Month drop-down list, choose a month (**January–December**) to start.
- g. From the End Day drop-down list, choose a day of the week (**Monday–Sunday**) to end.
- h. From the End Week drop-down list, choose an option (**first, 2nd, 3rd, or last**) to set the ending week. For example, choose **first** to configure summer time to end beginning the first week of the month or **last** to configure summer time to stop beginning the last week of the month.
- i. From the End Month drop-down list, choose a month (**January–December**) to end.

Step 6 From the Start Time drop-down lists, choose the hour (0–23) and minute (0–59) at which daylight saving time should start. From the End Time drop-down lists, choose the hour (0–23) and minute (0–59) at which daylight saving time should end.

Start Time and End Time fields for summer time are the times of the day when the clock is changed to reflect summer time. By default, both start and end times are set at 00:00.

Step 7 In the Offset field, specify the minutes offset from UTC (0–1439). (See [Table 10-3](#).)

The summer time offset specifies the number of minutes that the system clock moves forward at the specified start time and backward at the end time.

Step 8 Click the **No Customized Summer Time Configured** radio button to not specify a summer or daylight saving time for the corresponding time zone.

Step 9 Click **Submit** to save the settings.

A “Click Submit to Save” message appears in red next to the Current Settings line when there are pending changes to be saved after you have applied default or device group settings. You can also revert to the previously configured settings by clicking the Reset button. The Reset button is visible only when you have applied default or group settings to change the current device settings but have not yet submitted the changes.

If you attempt to leave this window without saving the modified settings, a warning dialog box prompts you to submit the changes. This dialog box only appears if you are using the Internet Explorer browser.

Table 10-2 *Timezone Location Abbreviations*

Time Zone	Expansion
CET	Central European Time
CST6CDT	Central Standard/Daylight Time
EET	Eastern European Time
EST	Eastern Standard Time
EST5EDT	Eastern Standard/Daylight Time
GB	Great Britain

Table 10-2 *Timezone Location Abbreviations (continued)*

Time Zone	Expansion
GB-Eire	Great Britain/Ireland
GMT	Greenwich Mean Time
HST	Hawaiian Standard Time
MET	Middle European Time
MST	Mountain Standard Time
MST7MDT	Mountain Standard/Daylight Time
NZ	New Zealand
NZ-CHAT	New Zealand, Chatham Islands
PRC	People's Republic of China
PST8PDT	Pacific Standard/Daylight Time
ROC	Republic of China
ROK	Republic of Korea
UCT	Coordinated Universal Time
UTC	Coordinated Universal Time
WET	Western European Time
W-SU	Middle European Time

Table 10-3 *Timezone—Offset from UTC*

Time Zone	Offset from UTC (in hours)
Africa/Algiers	+1
Africa/Cairo	+2
Africa/Casablanca	0
Africa/Harare	+2
Africa/Johannesburg	+2
Africa/Nairobi	+3
America/Buenos_Aires	-3
America/Caracas	-4
America/Mexico_City	-6
America/Lima	-5
America/Santiago	-4
Atlantic/Azores	-1
Atlantic/Cape_Verde	-1
Asia/Almaty	+6
Asia/Baghdad	+3
Asia/Baku	+4
Asia/Bangkok	+7
Asia/Colombo	+6
Asia/Dacca	+6
Asia/Hong_Kong	+8

Table 10-3 *Timezone—Offset from UTC (continued)*

Time Zone	Offset from UTC (in hours)
Asia/Irkutsk	+8
Asia/Jerusalem	+2
Asia/Kabul	+4.30
Asia/Karachi	+5
Asia/Katmandu	+5.45
Asia/Krasnoyarsk	+7
Asia/Magadan	+11
Asia/Muscat	+4
Asia/New Delhi	+5.30
Asia/Rangoon	+6.30
Asia/Riyadh	+3
Asia/Seoul	+9
Asia/Singapore	+8
Asia/Taipei	+8
Asia/Tehran	+3.30
Asia/Vladivostok	+10
Asia/Yekaterinburg	+5
Asia/Yakutsk	+9
Australia/Adelaide	+9.30
Australia/Brisbane	+10
Australia/Darwin	+9.30
Australia/Hobart	+10
Australia/Perth	+8
Australia/Sydney	+10
Canada/Atlantic	-4
Canada/Newfoundland	-3.30
Canada/Saskatchewan	-6
Europe/Athens	+2
Europe/Berlin	+1
Europe/Bucharest	+2
Europe/Helsinki	+2
Europe/London	0
Europe/Moscow	+3
Europe/Paris	+1
Europe/Prague	+1
Europe/Warsaw	+1
Japan	+9
Pacific/Auckland	+12
Pacific/Fiji	+12
Pacific/Guam	+10

Table 10-3 Timezone—Offset from UTC (continued)

Time Zone	Offset from UTC (in hours)
Pacific/Kwajalein	+12
Pacific/Samoa	–11
US/Alaska	–9
US/Central	–6
US/Eastern	–5
US/East–Indiana	–5
US/Hawaii	–10
US/Mountain	–7
US/Pacific	–8

UTC was formerly known as Greenwich Mean Time (GMT). The offset time (number of hours ahead or behind UTC) as displayed in the table is in effect during winter time. During summer time or daylight saving time, the offset may be different from the values in the table and is calculated and displayed accordingly by the system clock.

Configuring Secure Store Settings

Secure store encryption provides strong encryption and key management for your WAAS system. The WAAS Central Manager and WAE devices use secure store encryption for handling passwords, managing encryption keys, and for data encryption.

This section contains the following topics:

- [Secure Store Overview](#)
- [Enabling Secure Store Encryption on the Central Manager](#)
- [Enabling Secure Store Encryption on a Standby Central Manager](#)
- [Enabling Secure Store Encryption on a WAE Device](#)
- [Changing Secure Store Passphrase Mode](#)
- [Changing the Secure Store Encryption Key and Password](#)
- [Resetting Secure Store Encryption on a Central Manager](#)
- [Disabling Secure Store Encryption on a WAE Device](#)

Secure Store Overview

With secure store encryption on the Central Manager or a WAE device, the WAAS system uses strong encryption algorithms and key management policies to protect certain data on the system. This data includes encryption keys used by applications in the WAAS system, user login passwords and certificate key files.

Secure store encryption on the Central Manager is always enabled and uses a password that is auto-generated or user-provided. This password is used to generate the *key encryption key* according to secure standards. The WAAS system uses the key encryption key to encrypt and store other keys generated on the Central Manager or WAE devices. These other keys are used for WAAS functions including disk encryption, SSL acceleration, or to encrypt and user passwords.

Data on the Central Manager is encrypted using a 256-bit key encryption key generated from the password and using SHA1 hashing and an AES 256-bit algorithm. When secure store is enabled on a WAE device the data is encrypted using a 256-bit key encryption key generated using SecureRandom, a cryptographically strong pseudorandom number generator.

Secure store encryption on a Central Manager uses one of the following modes:

- Auto-generated passphrase mode—The passphrase is automatically generated by the Central Manager and used to open the secure store after each system reboot. This is the default mode for new Central Manager devices or after the system has been reinstalled.
- User-provided passphrase mode—The passphrase is supplied by the user and must be entered after each system reboot to open the secure store. You can switch to this mode, and systems upgraded from versions prior to 4.4.1, with secure store initialized, are configured in this mode after upgrading to 4.4.1 or later.

To implement secure store your system must meet the following requirements:

- You must have a Central Manager configured for use in your network.
- Your WAE devices must be registered with the Central Manager.
- Your WAE devices must be online (have an active connection) with the Central Manager. This requirement applies only if you are enabling secure store on WAE devices.
- All Central Managers and WAE devices must be running WAAS software version 4.0.19 or higher.

To implement strong store encryption, follow these steps:

-
- Step 1** Enable strong storage encryption on your primary Central Manager. See [Enabling Secure Store Encryption on the Central Manager](#).
 - Step 2** Enable strong storage encryption on any standby Central Managers. See [Enabling Secure Store Encryption on a Standby Central Manager](#).
 - Step 3** Enable strong storage encryption on WAE devices or WAE device groups. See [Enabling Secure Store Encryption on a WAE Device](#). (Secure store must be enabled on the Central Manager before you enable it on the WAE devices.)

You can enable secure store independently on the Central Manager and on the WAE devices. To ensure full protection of your encrypted data, enable secure store on both the Central Manager and the WAE devices. You must enable secure store on the Central Manager first.

**Note**

When you reboot the Central Manager, if secure store is in user-provided passphrase mode, you must manually open secure store encryption. All services that use the secure store (disk encryption, SSL acceleration, AAA, and so on) on the remote WAE devices do not operate properly until you enter the secure store password on the Central Manager to open secure store encryption.

Note the following considerations regarding the secure store:

- Passwords stored in the Central Manager database are encrypted using strong encryption techniques.

- Certificate key files are encrypted using the strong encryption key on the Central Manager.
- If a primary Central Manager fails, secure store key management is handled by the standby Central Manager. (Secure store mode must be enabled manually on the standby Central Manager.)
- Backup scripts back up the secure store passphrase mode (user-provided or auto-generated) of the device at the time of backup. Backup and restore are supported only on the Central Manager.
- If you have a backup made when the secure store was in user-provided passphrase mode and you restore it to a system where the secure store is in auto-generated passphrase mode, you must enter the user passphrase to proceed with the restore. After the restore, the system is in user-provided passphrase mode. If you have a backup made when the secure store was in auto-generated passphrase mode and you restore it to a system where the secure store is in user-provided passphrase mode, you do not need to enter a password. After the restore, the system is in auto-generated passphrase mode.
- When you enable secure store on a WAE device, the system initializes and retrieves a new encryption key from the Central Manager. The WAE uses this key to encrypt data credentials and information on the disk (if disk encryption is also enabled).
- When you reboot the WAE after enabling secure store, the WAE retrieves the key from the Central Manager automatically, allowing normal access to the data that is stored in WAAS persistent storage. If key retrieval fails, a critical alarm is raised and secure store should be reopened manually. Until secure store is reopened, the WAE rejects configuration updates from the Central Manager if the updates contain dynamic share, or user configuration. Also, the WAE does not include reposition configuration in the updates that it sends to the Central Manager.
- While secure store encrypts certain system information, it does not encrypt the data on the hard drives. To protect the data disks, you must enable disk encryption separately.

Enabling Secure Store Encryption on the Central Manager

Secure store is enabled by default on a new Central Manager, with a system-generated password that opens the secure store after the system boots. You do not need to do anything to enable secure store.

If a Central Manager is configured in user-provided passphrase mode, you must manually open the secure store after the system boots. To open secure store encryption on the Central Manager, follow these steps:

-
- Step 1** From the WAAS Central Manager menu, choose **Admin > Secure Store**. The Configure CM Secure Store window appears.
 - Step 2** Enter the secure store passphrase in the Current passphrase field under Open Secure Store.
 - Step 3** Click the **Open** button.

The secure store is opened. Data is encrypted using the key derived from the password.

To open the secure store from the CLI, use the **cms secure-store open EXEC** command.

**Note**

Whenever you reboot a Central Manager that is configured in user-provided passphrase mode, you must reopen the secure store manually. All services that use the secure store (disk encryption, SSL acceleration, AAA, and so on) on the remote WAE devices do not operate properly until you enter the secure store password on the Central Manager to reopen the secure store. Switch to auto-generated passphrase mode to avoid having to reopen the secure store after each reboot.

**Note**

When you enable secure store on the primary Central Manager in user-provided passphrase mode, you should enable secure store on the standby Central Manager as well. See [Enabling Secure Store Encryption on a Standby Central Manager](#).

You can check the status of secure store encryption by entering the **show cms secure-store** command.

Enabling Secure Store Encryption on a Standby Central Manager

**Note**

A standby Central Manager provides limited encryption key management support. If the primary Central Manager fails, the standby Central Manager provides only encryption key retrieval to the WAE devices but does not provide new encryption key initialization. Do not enable disk encryption or secure store on WAE devices when the primary Central Manager is not available.

The secure store passphrase mode on the primary Central Manager is replicated to the standby Central Manager (within the standard replication time). If the primary Central Manager is switched to auto-generated passphrase mode, the standby Central Manager secure store changes to the open state. If the primary Central Manager is switched to user-provided passphrase mode or the passphrase is changed, the standby Central Manager secure store changes to the initialized but not open state and an alarm is raised. You must manually open the secure store on the standby Central Manager.

To enable secure store encryption on a standby Central Manager when the primary Central Manager is in user-provided passphrase mode, open the secure store on the primary Central Manager and then use the CLI to execute the **cms secure-store open** EXEC mode command on the standby Central Manager:

- Step 1** Enable secure store encryption on the primary Central Manager. See [Enabling Secure Store Encryption on the Central Manager](#).
- Step 2** Wait until the standby Central Manager replicates the data from the primary Central Manager.
The replication should occur in 60 seconds (default) or as configured for your system.
- Step 3** Enter the **cms secure-store open** command on the standby Central Manager to activate secure store encryption.
The standby Central Manager responds with the “please enter pass phrase” message.
- Step 4** Type the password and press **Enter**.
The standby Central Manager encrypts the data using secure store encryption.

**Note**

Repeat Steps 3 and 4 for each standby Central Manager on your system.

You can check the status of secure store encryption by entering the **show cms secure-store** command.

Enabling Secure Store Encryption on a WAE Device

To enable secure store encryption on a WAE device, follow these steps:

- Step 1** From the WAAS Central Manager menu, choose **Devices > device-name** (or **Device Groups > device-group-name**).



Note The secure store status must be the same for all WAE devices in a device group. Either all WAE devices in the group must have secure store enabled, or all must have secure store disabled. Before you add a WAE device to a device group, set its secure store status to match the others. See [Working with Device Groups](#) in Chapter 3, “Using Device Groups and Device Locations.”

- Step 2** Choose **Configure > Security > Secure Store**. The Secure Store Settings window appears.
- Step 3** Check the **Initialize CMS Secure Store** box. (The Open CMS Secure Store box will be checked automatically.)
- Step 4** Click **Submit** to activate secure store encryption.

A new encryption key is initialized on the Central Manager, and the WAE encrypts the data using secure store encryption.

To enable secure store from the CLI, use the **cms secure-store init EXEC** command.



Note

If you have made any other CLI configuration changes on a WAE within the datafeed poll rate time interval (5 minutes by default) before executing the **cms secure-store** command, those prior configuration changes are lost and you must redo them.



Note

When you enable or disable secure store on a device group, the changes do not take effect on all WAE devices simultaneously. When you view the WAE devices be sure to give the Central Manager enough time to update the status of each WAE device.

Changing Secure Store Passphrase Mode

The secure store can operate either in user-provided or auto-generated passphrase mode and you can switch between these modes.

To change from user-provided to auto-generated passphrase mode, follow these steps:

- Step 1** From the WAAS Central Manager menu, choose **Admin > Secure Store**.
- Step 2** In the Switch to CM auto-generated passphrase mode area, enter the password in the Current passphrase field.
- Step 3** Click the **Switch** button.

Step 4 Click **OK** in the confirmation message that appears.

The secure store is changed to auto-generated passphrase mode and remains in the open state.

To change from auto-generated to user-provided passphrase mode, follow these steps:

Step 1 From the WAAS Central Manager menu, choose **Admin > Secure Store**.

Step 2 In the Switch to User-provided passphrase mode area, enter a password in the New passphrase field and reenter the password in the Confirm passphrase field.

The password must conform to the following rules:

- Be 8 to 64 characters in length
- Contain characters only from the allowed set: A-Za-z0-9~%#!#\$^&*()!;:,"<>/
- Contain at least one digit
- Contain at least one lowercase and one uppercase letter

Step 3 Click the **Switch** button.

Step 4 Click **OK** in the confirmation message that appears.

The secure store is changed to user-provided passphrase mode and remains in the open state. If you have a standby Central Manager, you must manually open its secure store (see [Enabling Secure Store Encryption on a Standby Central Manager](#)).

To change secure store passphrase mode from the CLI, use the **cms secure-store mode EXEC** command.



Note

Whenever you reboot a Central Manager that is configured in user-provided passphrase mode, you must reopen the secure store manually. All services that use the secure store (disk encryption, SSL acceleration, AAA, and so on) on the remote WAE devices do not operate properly until you enter the secure store password on the Central Manager to reopen the secure store. Switch to auto-generated passphrase mode to avoid having to reopen the secure store after each reboot.

Changing the Secure Store Encryption Key and Password

The secure store encryption password is used by the Central Manager to generate the encryption key for the encrypted data. If the Central Manager is configured for user-provided passphrase mode, you can change the password.

To change the password and generate a new encryption key on the Central Manager, follow these steps:

Step 1 From the WAAS Central Manager menu, choose **Admin > Secure Store**.

Step 2 In the Change Secure Store passphrase area, in the Current passphrase field, enter the current password.

Step 3 In the New passphrase field, enter the new password.

The password must conform to the following rules:

- Be 8 to 64 characters in length
- Contain characters only from the allowed set: A-Za-z0-9~%#!#\$^&*()!;:,"<>/

- Contain at least one digit
- Contain at least one lowercase and one uppercase letter

Step 4 In the Confirm passphrase field, enter the new password again.

Step 5 Click the **Change** button.

The WAAS device reencrypts the stored data using a new encryption key derived from the new password.



Note There may be a delay of a few minutes after you click the **Change** button before the changes take effect.

To change the password and generate a new encryption key on the Central Manager from the CLI, use the **cms secure-store change EXEC** command.

To generate a new encryption key for a WAE device from the WAAS Central Manager, follow these steps:

Step 1 From the WAAS Central Manager menu, choose **Devices > device-name** (or **Device Groups > device-group-name**).

Step 2 Choose **Configure > Security > Secure Store**.

Step 3 Check the **Change CMS Secure Store** box and then click **Submit**.

A new encryption key is generated in the Central Manager. The Central Manager replaces the encryption key in the WAE with the new key. The WAE re-encrypts the stored data using the new encryption key.



Note There may be a delay of a few minutes after you click the **Submit** button before the changes take effect.

To configure the secure store encryption key from the CLI, use the **cms secure-store change EXEC** command.

Resetting Secure Store Encryption on a Central Manager

You can reset the secure store if you reload the Central Manager and you cannot open the secure store because it is configured in user-provided passphrase mode and you forget the secure store password. This procedure deletes all encrypted data, certificate and key files, and key manager keys. The secure store is reinitialized, configured in auto-generated passphrase mode, and opened.

To reset secure store encryption on a Central Manager, follow these steps:

Step 1 At the primary Central Manager CLI, enter the **cms secure-store reset** command to reset secure store encryption.

Step 2 Wait until the standby Central Manager replicates the data from the primary Central Manager.

The replication should occur in 60 seconds (default) or as configured for your system.

- Step 3** Enter the **cms secure-store reset** command on the standby Central Manager if secure store is in the initialized and open state.
- Step 4** From the primary Central Manager, reset all user account passwords .
For information on resetting user passwords, see [Changing the Password for Another Account](#) in Chapter 8, “Creating and Managing Administrative User Accounts and Groups.”
- Step 5** On each WAE registered to the Central Manager, follow these steps:
- If secure store is initialized and open, from the Central Manager, clear secure store (see [Disabling Secure Store Encryption on a WAE Device](#)). Or, from the CLI, enter the **cms secure-store clear EXEC** command.
 - From the Central Manager, initialize secure store (see [Enabling Secure Store Encryption on a WAE Device](#)) or from the CLI, enter the **cms secure-store init EXEC** command. (This step is needed only if you performed [Step 5a.](#))
 - Enter the **crypto pki managed-store initialize** command and restart the SSL accelerator.
 - If disk encryption is enabled, from the Central Manager, disable disk encryption or from the CLI, enter the **no disk encrypt enable** global configuration command.
 - If disk encryption had been enabled before [Step 5d](#), reload the device. After the reload, reenables disk encryption and reload the device again.



Note If the WAE is reloaded before doing [Step 5](#), disk encryption, SSL acceleration, and secure store does not function properly. In this case, you must restore the WAE to factory defaults.

- Step 6** From the primary Central Manager, reimport all certificate and key files for all the accelerated and peering services which are configured on the WAEs.
-

Disabling Secure Store Encryption on a WAE Device

To disable secure store encryption on a WAE device, follow these steps:

-
- Step 1** From the WAAS Central Manager menu, choose **Devices > device-name** (or **Device Groups > device-group-name**).
- Step 2** Choose **Configure > Security > Secure Store**. The Secure Store Settings window appears.
- Step 3** Check the **Clear CMS Secure Store** box and then click Submit to disable secure store encryption and return to standard encryption.

You can also enter the **cms secure-store clear** command to disable secure store encryption and return to standard encryption.

Consider the following when you disable Secure Store in the WAAS CM or with the **cms secure-store clear** command:

- There may be a delay of a few minutes for the changes to take effect, after you either click **Submit** at the Secure Store Settings window, or enter the **cms secure-store clear** command at the CLI.

- If a Windows Domain User account identity has been configured on the device or the device group for encrypted-mapi acceleration, you will not be able to clear the secure store on the device. You must remove the Windows domain user account identity configuration from the device or device group before you can clear secure store.
- You cannot clear secure store on a device that contains an encrypted services user account domain identity. See [Configuring Encrypted MAPI Acceleration](#) in Chapter 12, “Configuring Application Acceleration” for more information on user account domain identities.
- To disable secure store on a WAE from the CLI, use the **cms secure-store clear EXEC** command.
- Secure store cannot be disabled on a Central Manager.

Modifying the Default System Configuration Properties

The WAAS software comes with preconfigured system properties that you can modify to alter the default behavior of the system.

[Table 10-4](#) describes the system configuration properties that you can modify.

Table 10-4 Descriptions for System Configuration Properties

System Property	Description
cdm.remoteuser.deletionDaysLimit	Maximum number of days since their last login after which external users will be deleted from the WAAS Central Manager database. For example, if cdm.remoteuser.deletionDaysLimit is set to 5, external users will be deleted from the database if the difference between their last login time and the current time is more than 5 days. The default is 60 days. External users are users that are defined in an external AAA server and not in the WAAS Central Manager. Any reports scheduled by such users are also deleted when the users are deleted.
cdm.session.timeout	Timeout in minutes of a WAAS Central Manager GUI session. The default is 10 minutes. If the session is idle for this length of time, the user is automatically logged out.
DeviceGroup.overlap	Status of whether a device can belong to more than one device group. The default is true (devices can belong to more than one device group).
System.clusterStatus.collectRate	The rate (in seconds) at which AppNav Controller collects and sends Cluster status to the WAAS Central Manager from the AppNav IOM. The default is 30 seconds.
System.datafeed.pollRate	Poll rate between a WAAS (or WAAS Express) device and the WAAS Central Manager (in seconds). The default is 300 seconds.
System.device.recovery.key	Device identity recovery key. This property enables a device to be replaced by another node in the WAAS network.
System.healthmonitor.collectRate	Collect and send rate in seconds for the CMS device health (or status) monitor. If the rate is set to 0, the health monitor is disabled. The default is 120 seconds.

Table 10-4 Descriptions for System Configuration Properties (continued)

System Property	Description
System.IOS.clusterStatus.collectRate	The rate (in seconds) at which the Central Manager collects Cluster Status data from Cisco IOS Routers.
System.IOS.clusterTopologyView.collectRate	The rate (in seconds) at which the Central Manager collects Cluster Status data from Cisco IOS Routers for Cluster Topology view.
System.lcm.enable	This setting controls propagation of device CLI configuration changes back to the CM. If disabled, configuration changes done in device's CLI will not be communicated to the Central Manager. This setting is system wide and applies to all managed WAAS devices. Note that disabling this setting may result in Central Manager and WAAS device(s) configuration to go out of sync. You can customize this setting for specific device in Device -> Admin -> Config Synchronization UI page.
System.pcm.enable	This setting controls whether WAAS devices accept or ignore configuration changes received from the Central Manager. It could be used in deployments where WAAS devices are not managed by Central Manager but other entity (i.e. directly via CLI). Note that disabling this setting may result in Central Manager and WAAS device(s) configuration to go out of sync. You can customize this setting for specific device in Device -> Admin -> Config Synchronization UI page.
System.monitoring.collectRate	Rate at which a WAE collects and sends the monitoring report to the WAAS Central Manager (in seconds). For a WAAS Express device, this is the rate at which the Central Manager collects the monitoring data from the WAAS Express device. The default is 300 seconds (5 minutes). Reducing this interval impacts the performance of the WAAS Central Manager device.
System.monitoring.dailyConsolidationHour	Hour at which the WAAS Central Manager consolidates hourly and daily monitoring records. The default is 1 (1:00 a.m.).
System.monitoring.enable	WAAS and WAAS Express statistics monitoring (enable or disable). The default is true.
System.monitoring.maxConsecutiveRpcErrorWaitCount	Maximum number of RPC failures after which statistics from WAE to Central Manager will not be transmitted.
System.monitoring.maxDevicePerLocation	Maximum number of devices for which monitoring is supported in location level reports. The default is 25.
System.monitoring.maxReports	Maximum number of completed or failed report instances to store for each custom report. The default is 10 report instances.

Table 10-4 Descriptions for System Configuration Properties (continued)

System Property	Description
System.monitoring.monthlyConsolidationFrequency	<p>How often (in days) the WAAS Central Manager consolidates daily monitoring records into monthly records. If this setting is set to 1, the WAAS Central Manager checks if consolidation needs to occur every day, but only performs consolidation if there is enough data for consolidation to occur. The default is 14 days.</p> <p>When a monthly data record is created, the corresponding daily records are removed from the database. Consolidation occurs only if there is at least two calendar months of data plus the consolidation frequency days of data. This ensures that the WAAS Central Manager always maintains daily data records for the past month and can display data on a day level granularity for the last week.</p> <p>For example, if data collection starts on February 2nd, 2006 and System.monitoring.monthlyConsolidationFrequency is set to 14, then the WAAS Central Manager checks if there is data for the past two calendar months on the following days: Feb 16th, March 2nd, March 16th, and March 30th. No consolidation will occur because there is not enough data on these days.</p> <p>On April 13th, however, two calendar months of data exists. The WAAS Central Manager then consolidates data for the month of February and deletes the daily data records for that month.</p>
System.monitoring.recordLimitDays	Maximum number of days of monitoring data to maintain in the system. The default is 1825 days.
System.monitoring.timeFrameSettings	Default time frame to be used for plotting all the charts. Settings saved by the user will not be changed. The default is Last Hour.
System.registration.autoActivation	Status of the automatic activation feature, which automatically activates WAAS and WAAS Express devices that are registered to the Central Manager. The default is true (devices are automatically registered).
System.rpc.timeout.syncGuiOperation	Timeout in seconds for the GUI synchronization operations for the Central Manager to WAE connection. The default is 50 seconds.
System.security.maxSimultaneousLogins	Maximum number of concurrent WAAS Central Manager sessions permitted for a user. Specify 0 (zero, the default) for unlimited concurrent sessions. A user must log off the Central Manager to end a session. If a user closes the browser without logging off, the session is not closed until after it times out after 120 minutes (the timeout is not configurable). If the number of concurrent sessions permitted also is exceeded for that user, there is no way for that user to regain access to the Central Manager GUI until after the timeout expires. This setting does not affect CLI access to the Central Manager device.
System.security.webApplicationFilter	Status of the web application filter, which rejects any javascript, SQL, or restricted special characters in input. The default is false.

Table 10-4 Descriptions for System Configuration Properties (continued)

System Property	Description
System.standby.replication.maxCount	Maximum number of statistics data records (in thousands) that will be replicated to a standby Central Manager. The range is 10 to 300. The default is 200 (200,000 records). We do not recommend increasing this number.
System.standby.replicationTimeout	Maximum number of seconds to wait for replication to a standby Central Manager. The range is 300 to 3600 seconds. The default is 900 seconds. We do not recommend decreasing this timeout.
System.WcmIosUser.enable	Enables creation of WCM user on the registered IOS device. Global / device level / DG level IOS Router credential pages will be hidden if this system property is enabled.

To view or modify the value of a system property, follow these steps:

-
- Step 1** From the WAAS Central Manager menu, choose **Configure > Global > System Properties**. The Config Properties window appears.
 - Step 2** Click the **Edit** icon next to the system property that you want to change. The Modifying Config Property window appears.
 - Step 3** From a drop-down list, enter a new value or choose a new parameter, depending on the system property that you want to change.
 - Step 4** Click **Submit** to save the settings
-

Configuring the Web Application Filter

Web Application Filter is a security feature that protects the WAAS Central Manager GUI against Cross-Site Scripting (XSS) attacks. XSS security issues can occur when an application sends data that originates from a user to a web browser without first validating or encoding the content, which can allow malicious scripting to be executed in the client browser, potentially compromising database integrity.

This security feature verifies that all application parameters sent from WAAS users are validated and/or encoded before populating any HTML pages.

This section contains the following topics:

- [Enabling the Web Application Filter](#)
- [Security Verification](#)

Enabling the Web Application Filter

To enable the Web Application Filter, follow these steps:

-
- Step 1** From the WAAS Central Manager menu, choose **Configure > Global > System Properties**. The Config Properties window appears.



Note You cannot enable this feature using the CLI. This feature is disabled by default.

- Step 2** Click the Edit icon next to the `system.security.webApplicationFilter` entry.
The Modifying Config Property window appears.
- Step 3** Choose **true** from the Value drop-down list to enable this feature.
A confirmation message appears to advise Central Manager users to log out and then back in after enabling this feature.
- Step 4** Click **OK** and then **Submit**.
- Step 5** Log out and then back in again.
-

Security Verification

The Web Application Filter feature verifies security using two methods, input verification and sanitization. Input validation validates all input data before accepting data. Sanitization prevents malicious configuration and scripts already present in the data from getting executed.

This section contains the following topics:

- [Input Validation](#)
- [Sanitization](#)

Input Validation

Input validation scans all data that is input to the Central Manager database and is only configurable by the admin user.

Any input submitted using the Central Manager GUI that is suspicious of XSS is blocked. Blocked input results in a warning.

Input data is checked against the following XSS filter rules:

- Input is rejected if it contains a semicolon (;)
- Input is rejected if it is enclosed in angle brackets (<>)
- Input is rejected if it can be indirectly used to generate the above tags (<, >, %3c, %3e)

Sanitization

The sanitizer prevents malicious configuration and scripts from getting executed in the browser when there is an XSS attack on the database. Sanitization is not configurable by the user.

Configuration data coming from the Central Manager that is suspect for XSS is shown in red on the Device Groups > All Device Groups page.

Configuring Faster Detection of Offline WAAS Devices

You can detect offline WAAS devices more quickly if you enable the fast detection of offline devices. A WAAS device is declared as offline when it has failed to contact the WAAS Central Manager for a getUpdate (get configuration poll) request for at least two polling periods. (See [About Faster Detection of Offline Devices](#) for more information about this feature.)

To configure fast detection of offline WAAS devices, follow these steps:

- Step 1** From the WAAS Central Manager menu, choose **Configure > Global > Fast Device Offline Detection**. The Configure Fast Offline Detection window appears.



Note The fast detection of offline devices feature is in effect only when the WAAS Central Manager receives the first UDP heartbeat packet and a getUpdate request from a device.

- Step 2** Check the **Enable Fast Offline Detection** check box to enable the WAAS Central Manager to detect the offline status of devices quickly.

- Step 3** In the Heartbeat Rate field, specify how often devices should transmit a UDP heartbeat packet to the WAAS Central Manager, in seconds. The default is 30 seconds.

- Step 4** In the Heartbeat Fail Count field, specify the number of UDP heartbeat packets that can be dropped during transmission from devices to the WAAS Central Manager before a device is declared offline. The default is 1.

- Step 5** In the Heartbeat UDP Port field, specify the port number using which devices will send UDP heartbeat packets to the primary WAAS Central Manager. The default is port 2000.

The Maximum Offline Detection Time field displays the product of the failed heartbeat count and heartbeat rate.

Maximum Offline Detection Time = Failed heartbeat count * Heartbeat rate

If you have not enabled the fast detection of offline devices feature, then the WAAS Central Manager waits for at least two polling periods to be contacted by the device for a getUpdate request before declaring the device to be offline. However, if you enable the fast detection of offline devices feature, then the WAAS Central Manager waits until the value displayed in the Maximum Offline Detection Time field is exceeded.

If the WAAS Central Manager receives the Cisco Discovery Protocol (CDP) from a device, then the WAAS Central Manager GUI displays the device as offline after a time period of 2* (heartbeat rate) * (failed heartbeat count).

- Step 6** Click **Submit**.



Note Any changes to the Configure Fast WAE offline detection page in the Central Manager could result in devices temporarily appearing to be offline. Once the configuration changes are propagated to the devices, they show as online again.

About Faster Detection of Offline Devices

Communication between the WAAS device and WAAS Central Manager using User Datagram Protocol (UDP) allows faster detection of devices that have gone offline. UDP heartbeat packets are sent at a specified interval from each device to the primary WAAS Central Manager in a WAAS network. The primary WAAS Central Manager tracks the last time that it received a UDP heartbeat packet from each device. If the WAAS Central Manager has not received the specified number of UDP packets, it displays the status of the nonresponsive devices as offline. Because UDP heartbeats require less processing than a getUpdate request, they can be transmitted more frequently, and the WAAS Central Manager can detect offline devices much faster.

You can enable or disable this feature, specify the interval between two UDP packets, and configure the failed heartbeat count. Heartbeat packet rate is defined as the interval between two UDP packets. Using the specified heartbeat packet rate and failed heartbeat count values, the WAAS Central Manager GUI displays the resulting offline detection time as a product of heartbeat rate and failed heartbeat count. If the fast detection of offline devices is enabled, the WAAS Central Manager detects devices that are in network segments that do not support UDP and uses getUpdate (get configuration poll) request to detect offline devices.

By default, the feature to detect offline devices more quickly is not enabled.

Configuring Alarm Overload Detection

WAAS devices can track the rate of incoming alarms from the Node Health Manager. If the rate of incoming alarms exceeds the high-water mark (HWM), then the WAAS device enters an alarm overload state. This situation occurs when multiple applications raise alarms at the same time to report error conditions. When a WAAS device is in an alarm overload state, the following occurs:

- SNMP traps for subsequent alarm raise and clear operations are suspended. The trap for the raise alarm-overload alarm and the clear alarm-overload alarm are sent; however, traps related to alarm operations between the raise alarm-overload alarm and the clear alarm-overload alarm operations are suspended.
- Alarm overload raise and clear notifications are not blocked. The alarm overload state is communicated to SNMP and the Configuration Management System (CMS). However, in the alarm overload state, SNMP and the CMS are not notified of individual alarms. The information is only available by using the CLI.
- The WAAS device remains in an alarm overload state until the rate of incoming alarms decreases to the point that the alarm rate is less than the low-water mark (LWM).
- If the incoming alarm rate falls below the LWM, the WAAS device comes out of the alarm overload state and begins to report the alarm counts to SNMP and the CMS.

When the WAAS device is in an alarm overload state, the Node Health Manager continues to record the alarms being raised on the WAAS device and keeps a track of the incoming alarm rate. Alarms that have been raised on a WAAS device can be listed using the **show alarm** CLI commands that are described in the *Cisco Wide Area Application Services Command Reference*.

To configure alarm overload detection for a WAAS device (or device group), follow these steps:

-
- Step 1** From the WAAS Central Manager menu, choose **Devices > device-name** (or **Device Groups > device-group-name**).
- Step 2** Choose **Configure > Monitoring > Alarm Overload Detection**. The Alarm Overload Detection Settings window appears.

- Step 3** Uncheck the **Enable Alarm Overload Detection** check box if you do not want to configure the WAAS device (or device group) to suspend alarm raise and clear operations when multiple applications report error conditions. This check box is checked by default.
- Step 4** In the Alarm Overload Low Water Mark (Clear) field, enter the number of incoming alarms per second below which the WAAS device comes out of the alarm overload state.
- The low-water mark is the level up to which the number of alarms must drop before alarms can be restarted. The default value is 1. The low-water mark value should be less than the high-water mark value.
- Step 5** In the Alarm Overload High Water Mark (Raise) field, enter the number of incoming alarms per second above which the WAAS device enters the alarm overload state. The default value is 10.
- Step 6** Click **Submit** to save the settings.
-

To configure alarm overload detection from the CLI, you can use the **alarm overload-detect** global configuration command.

Configuring the E-mail Notification Server

You can schedule reports to be generated periodically, and when they are generated, a link to the report can be e-mailed to one or more recipients. (For details, see [Managing Reports](#) in Chapter 14, “Monitoring Your WAAS Network.”)

To enable e-mail notification, you must configure e-mail server settings for the WAAS Central Manager by following these steps:

-
- Step 1** From the WAAS Central Manager menu, choose **Devices > device-name**. You must choose a Central Manager device.
- Step 2** Choose **Configure > Monitoring > Email Notification**. The Configure Email Server Details window appears.
- Step 3** In the Mail Server Hostname field, enter the hostname of the SMTP e-mail server that is to be used to send e-mail.



Note Only SMTP mail servers are supported. If any other type of mail server is configured, the email notification fails.

- Step 4** In the Mail Server Port field, enter the port number. The default is port 25.
- Step 5** In the Server Username field, enter a valid e-mail account username.
- Step 6** In the Server Password field, enter the password for the e-mail account.
- Step 7** In the From Address field, enter the e-mail address shown as the sender of the e-mail notification.
- Step 8** Click **Submit**.
-

Using IPMI over LAN

Intelligent Platform Management Interface (IPMI) over LAN provides remote platform management service for WAVE-294/594/694/7541/7571/8541 appliances. IPMI is an open standard technology that defines how administrators monitor system hardware and sensors, control system components, and retrieve logs of important system events to conduct remote management and recovery. IPMI runs on the Baseboard Management Controller (BMC) and operates independently of WAAS. After IPMI over LAN is set up and enabled on WAAS, authorized users can access BMC remotely even when WAAS becomes unresponsive or the device is powered down but connected to a power source. You can use an IPMI v2 compliant management utility, such as `ipmitool` or `OSA SMbridge`, to connect to the BMC remotely to perform IPMI operations.

The IPMI over LAN feature provides the following remote platform management services:

- Supports the power on, power off, and power cycle of the WAAS appliance.
- Monitors the health of the WAAS hardware components by examining Field Replaceable Unit (FRU) information and reading sensor values.
- Retrieves logs of important system events to conduct remote management and recovery.
- Provides serial console access to the WAAS appliance over the IPMI session.
- Support for IPMI Serial over LAN (SoL)—IPMI SoL enables a remote user to access a WAAS appliance through a serial console through an IPMI session.

IPMI over LAN and IPMI SoL features can be configured using CLI commands and include the following:

- Configuring IPMI LAN interface
- Configuring IPMI LAN users
- Configuring security settings for remote IPMI access
- Enabling/disabling IPMI over LAN
- Enabling/disabling IPMI SoL
- Restoring the default settings for the BMC LAN channel
- Displaying the current IPMI over LAN and IPMI SoL configurations

For more information on configuring IPMI over LAN, see [Configuring BMC for Remote Platform Management](#).

BMC Firmware Update

IPMI over LAN requires that a specific BMC firmware version be installed on the device. The minimum supported BMC firmware versions are:

- WAVE-294/594/694—48a
- WAVE-7541/7571/8541—26a

WAAS appliances shipped from the factory with WAAS version 4.4.5 or later do have the correct firmware installed. If you are updating a device that was shipped with an earlier version of WAAS software, you must update the BMC firmware, unless it was updated previously.

To determine if you are running the correct firmware version, use the `show bmc info` command. The following example displays the latest BMC firmware version installed on the device (48a here):

```
wave# show bmc info
Device ID           : 32
Device Revision     : 1
```



```

Firmware Revision           : 0.48                <<<<< version 48
IPMI Version                 : 2.0
Manufacturer ID              : 5771
Manufacturer Name            : Unknown (0x168B)
Product ID                   : 160 (0x00a0)
Product Name                 : Unknown (0xA0)
Device Available              : yes
Provides Device SDRs         : no
Additional Device Support    :
    Sensor Device
    SDR Repository Device
    SEL Device
    FRU Inventory Device
Aux Firmware Rev Info        :
    0x0b
    0x0c
    0x08
    0x0a                <<<<< a
. . .

```

If a BMC firmware update is needed, you can download it from cisco.com at the [Wide Area Application Service \(WAAS\) Firmware](#) download page (registered customers only). The firmware binary image is named `waas-bmc-installer-48a-48a-26a-k9.bin` or a newer version may be available. Use the latest firmware update that is available.

You can use the following command to update the firmware from the image file that is available through FTP on your network:

```
copy ftp install ip-address remotefiledir waas-bmc-installer-48a-48a-26a-k9.bin
```

The update process automatically checks the health status of the BMC firmware. If BMC firmware corruption is detected, BMC is recovered during the BMC firmware update procedure. The complete update process can take several minutes and the device may appear unresponsive but do not interrupt the process or power cycle the device. After the update is complete, you must reload the device.

After the device reboots, you can verify the firmware version by using the **show bmc info** command.

BMC recovery and BMC firmware update restores the factory defaults on the BMC and all the current IPMI over LAN configurations are erased.

If BMC firmware corruption happens, a critical alarm is raised.

Configuring BMC for Remote Platform Management

This section describes the minimum steps needed to enable IPMI over LAN and IPMI SoL to conduct remote platform management. This section includes the following topics:

- [Enabling IPMI Over LAN](#)
- [Enabling IPMI SoL](#)

Enabling IPMI Over LAN

To enable IPMI over LAN, perform the following steps using the **bmc lan** command:

-
- Step 1** Change the default BMC LAN IP address.
 - Step 2** Change the password for the BMC default user, which is user 2.
 - Step 3** Enable IPMI over LAN.

- Step 4** Access the BMC from a remote client over IPMI session v2.0 using the username and password for the number 2 user. The default cipher suite used to access the BMC is 3, which specifies RAKP-HMAC-SHA1 authentication, HMAC-SHA1-96 integrity, and AES-CBC-128 encryption algorithms.
- Step 5** To access the BMC over a IPMI session v1.5, change the user 2 IPMI-session-version setting from v2.0 to v1.5.
-

Enabling IPMI SoL

To enable IPMI SoL, perform the following steps:

- Step 1** On the WAAS device, configure and enable IPMI over Lan (IoL).
- Step 2** On the remote client make sure that the BMC user can do IoL operations successfully over IPMI session v2.0.
- Step 3** On the remote client, change the baud-rate of the terminal to match the WAAS console baud rate of 9600 bps.
- Step 4** On the WAAS device, enable IPMI SoL.
- Step 5** On the remote client, if the IPMI management tool is ipmitool, check the SoL payload status of the specific BMC user with the following command:
ipmitool -I lanplus -H bmc-ip-address -U bmc-user-name sol payload status 1 bmc-user-userid
 For example:

```
# ipmitool -I lanplus -H 2.1.4.70 -U user3 sol payload status 1 3
Password:
User 3 on channel 1 is disabled
```
- Step 6** If the SoL payload is disabled for this user, enable the SoL payload for this user with the following command:
ipmitool -I lanplus -H bmc-ip-address -U bmc-user-name sol payload enable 1 bmc-user-userid
 For example:

```
# ipmitool -I lanplus -H 2.1.4.70 -U user3 sol payload enable 1 3
Password:
# ipmitool -I lanplus -H 2.1.4.70 -U user3 sol payload status 1 3
Password:
User 3 on channel 1 is enabled
```
- Step 7** On the remote client, use the following command to open the serial console to the WAAS device:
ipmitool -I lanplus -H bmc-ip-address -U bmc-user-name sol activate
- Step 8** On the remote client, you have now entered the console session of the WAAS device. When you are done, use the ~. escape character to terminate the connection.
-

Managing Cisco IOS Router Devices

You can use the WAAS Central Manager to manage WAAS Express and AppNav-XE devices, which are both Cisco IOS routers deployed with WAAS related software. The Central Manager menu displays a subset of the full menu when a WAAS Express or device AppNav-XE is selected as the context, as these devices implement a subset of WAAS appliance functionality.

The Central Manager and a Cisco IOS device communicate using the HTTPS protocol. To establish communication between a WAAS Central Manager and a Cisco IOS router device, you must register the Cisco IOS router device with the Central Manager. Using the Central Manager GUI to register a Cisco IOS router device is the easiest method.

This section includes the following topics:

- [Registering a Cisco IOS Router Device Using the Central Manager GUI](#)
- [Configuring Router Credentials](#)
- [Registering a Cisco IOS Router Using the CLI](#)
- [Reimporting a Router Device Certificate](#)

Registering a Cisco IOS Router Device Using the Central Manager GUI

All banner configurations (with keywords such as username, password, hostname etc.) must be removed from the router, before you register it with the WAAS Central Manager because it interferes with the registration process and throws up inadvertent errors.

To register a Cisco IOS router device, follow these steps:

-
- Step 1** From the WAAS Central Manager menu, choose **Admin > Registration > Cisco IOS Routers**. The Cisco IOS Router Registration window appears.



Note To register a Cisco IOS router device using the Central Manager GUI, SSH v1 or v2 must be enabled on the router.

- Step 2** Select the type of IP address (IPv4 or IPv6) that the Router will use. The IPv6 option is available only when the Central Manager is configured with a valid IPv6 address.

- Step 3** In the IP Address(es) field, enter the router IP addresses to register, separated by commas. The IP address, hostname, router type, and status are displayed in the Registration Status table.



Note Although an IOS router can have a dot (“.”) in the hostname, this special character is not allowed in a WAAS device hostname. If you try to import an AppNav-XE device that has a dot in the hostname, the import will fail and the following error message is displayed: `Registration failed for the device devicename ConstraintException; Invalid AppNav-XE name: X.X since name includes invalid character `.``.

You may also upload a CSV file that contains a list of IP addresses to register. To upload a list, click the **Import CSV file** radio button and click the **Choose File** button to browse to the file and click **Open**. Each IP address must be on a separate line.

- Step 4** Configure the router login credentials by entering the username, password, and enable password. If you need to create a user on the router, see [Configuring a User](#).

Step 5 Choose the HTTP Authentication Type, local or AAA.



Note Be sure to choose the HTTP authentication type that is currently configured on the router. If you choose an HTTP authentication type that differs from your current configuration, your existing configuration on the router will be overwritten and you may not be able to use HTTP to communicate with the router. Communications with routers with previously established authentication credentials will fail.

Step 6 In the Central Manager IP Address field, enter the IP address you want the router to use for the Central Manager. This field is initially filled in with the current Central Manager IP address but you may need to change this in a NAT environment.

Step 7 Click the Register button and verify that the registration status was successful.

You may view the results in the log file: /local/local1/errlog/waasx-audit.log

After you successfully register a Cisco IOS router device, the Central Manager displays it in the Registration Status table and in the All Devices list.

In case you want to register additional devices, use the Reset button to clear data from all the fields, to enter the next configuration.

You may need to install a software license on the Cisco IOS router device. For details, see [Installing a License on the Router](#).

Configuring Router Credentials

For the Central Manager to access a Cisco IOS router device, you must configure the router credentials in the Central Manager.

On the Central Manager, you can define global credentials that apply to all Cisco IOS router devices, or you can define credentials at the device group or individual device level by using the Admin > Authentication > WAAS Express Credentials/AppNav-XE Credentials menu item. To configure device group or individual device credentials, you must first complete the Cisco IOS router registration process and then configure credentials for a router device group or device. Device and device group credentials have precedence over global credentials.

To configure global router credentials, follow these steps:

Step 1 From the WAAS Central Manager menu, choose **Admin > Security > Cisco IOS Router Global Credentials**. The Cisco IOS Router Global Credentials window appears.

Step 2 In the Username field, enter a username that is defined on the Cisco IOS router. If you need to create a user on the router, see [Configuring a User](#).



Note The username field is optional if you are not using local or AAA authentication for the HTTP server on the Cisco IOS router device; that is, if you use the default HTTP server configuration of **ip http authentication enable**. (See [Enabling the HTTP Secure Server on the Router](#).)

Step 3 In the Password field, enter the password for the specified username.

Step 4 Click **Submit**.

To configure credentials at the device group or individual device level, follow these steps:

Step 1 From the WAAS Central Manager menu, choose **Devices** > device-name (or **Device Groups** > device-group-name). The Device/ Device Group Home page appears. Go to **Admin** > **Authentication** > **WAAS Express Credentials/AppNav-XE Credentials** menu item.

Step 2 In the Username field, enter a username that is defined on the Cisco IOS router. If you need to create a user on the router, see [Configuring a User](#).



Note The username field is optional if you are not using local or AAA authentication for the HTTP server on the Cisco IOS router device; that is, if you use the default HTTP server configuration of **ip http authentication enable**. (See [Enabling the HTTP Secure Server on the Router](#).)

Step 3 In the Password field, enter the password for the specified username.

Step 4 Click **Submit**.



Note Changing the router credentials on the Central Manager does not change the configuration on the router device itself. It affects only the router credentials that are stored on the Central Manager.

Registering a Cisco IOS Router Using the CLI

You can also register a Cisco IOS router device with the Central Manager using the CLI by completing the steps outlined in [Table 10-5](#). This procedure applies to Cisco IOS routers running both WAAS Express and AppNav-XE.

Table 10-5 Checklist for Registering a Cisco IOS Router Using the CLI

Task	Additional Information and Instructions
1. Configure a username and password.	The same username and password are configured on the router and the Central Manager, so the Central Manager can log in to the router for management purposes. For more information, see Configuring a User .
2. Import the primary Central Manager administrative server certificate into the router.	The router requires the Central Manager certificate for secure HTTPS server communication. For more information, see Importing the Central Manager Certificate .
3. Configure a router certificate.	The Central Manager device requests this router certificate for secure HTTPS server communication. For more information, see Configuring a Router Certificate .
4. Enable the secure HTTP server with user authentication.	Enables the Central Manager and router to communicate. For more information, see Enabling the HTTP Secure Server on the Router .

Table 10-5 Checklist for Registering a Cisco IOS Router Using the CLI (continued)

Task	Additional Information and Instructions
5. Install a permanent WAAS software license.	Allows the WAAS software to operate on the router. For more information, see Installing a License on the Router .
6. Configure an NTP server.	Keeps the time synchronized between the router and the Central Manager. For more information, see Configuring an NTP Server .
7. Register the router with the Central Manager.	Registers the router with the Central Manager. For more information, see Registering the Router .

The following sections describe these steps in detail.

Configuring a User

The first step in setting up your router and Central Manager to communicate is to configure the same user on the router and the Central Manager.

To configure a user, follow these steps:

Step 1 Log in to the router CLI.

Step 2 Configure local authentication using the following commands:

```
router# configure terminal
router(config)# aaa new-model
router(config-if)# aaa authentication login default local
router(config)# line vty 0 4
Router(config-line)# login authentication default
router(config-line)# end
```



Note This command varies based on the IOS and IOS XE version. For more information see [Authentication commands](#).

Step 3 Configure a local user with privilege level 15 on the router by using the **username** IOS configuration command:

```
router#config t
Enter configuration commands, one per line. End with CNTL/Z.
router(config)#username cisco privilege 15 password 0 cisco
router(config)#exit
```

Alternatively, you can configure an external TACACS+ or RADIUS user; see details after this procedure.

Step 4 Save the running configuration:

```
router#write memory
Building configuration...
[OK]
```

Step 5 In the WAAS Central Manager, configure the router credentials as described in [Configuring Router Credentials](#).

To configure an external TACACS+ user on the router, use the following configuration commands on the router:

```
router#config t
Enter configuration commands, one per line. End with CNTL/Z.
router(config)#aaa new-model
router(config)#aaa authentication login default group tacacs+
router(config)#aaa authorization exec default group tacacs+
router(config)#tacacs-server host host-ip
router(config)#tacacs-server key keyword
```

To configure an external RADIUS user on the router, use the following configuration commands on the router:

```
router#config t
Enter configuration commands, one per line. End with CNTL/Z.
router(config)#aaa new-model
router(config)#aaa authentication login default group radius
router(config)#aaa authorization exec default group radius
router(config)#radius-server host host-ip
router(config)#radius-server key keyword
```

The external authentication server for TACACS+ or RADIUS must be Cisco ACS 4.x or 5.x.

Importing the Central Manager Certificate

The next step is to import the certificate from the Central Manager into the router.

To import the certificate, follow these steps:

-
- Step 1** Log in to the Central Manager CLI.
 - Step 2** Display the administrative certificate by using the show crypto EXEC command:

```
waas-cm#show crypto certificate-detail admin

...
-----BEGIN CERTIFICATE-----
TIIcEzCCAeSgAwIBAgIEVwMK8zANBgkqhkiG9w0BAQUFADCBgTELMAkGA1UEBhMC
VVMxEzARBgNVBAGTCkNhbG1mb3JuaWEeXETAPBgNVBACTCFNhbiBKb3NlMQ0wCwYD
VQQLERwRDTkVMRswGQYDVQQKEExJDaXNjbyBTeXN0ZW1zLCBjb250aW50aW50aW50
FWRvYy13YWFzLWwNtLmNpc2NvLmNvbTAeFw0wODA3MjQxOTMwMjNaFw0xMzA3MjMx
OTMwMjNaMIGBMQswCQYDVQQGEwJVUzETMBEGA1UECBMKQ2FsaWZvcml5TERMA8G
A1UEBxMIU2FuIEpvc2UxDTALBgNVBAsTBENoQ1UxGzAZBgNVBAoTEkNpc2NvIFN5
c3RlbXMsIEl1eYzEeMBwGALUEAxMVZG9jLXdhYXN0Y20uY21zY28uY29tMIGfMA0G
CSqGSIb3DQEBQUAA4GNADCBiQKBgQC10xBfsUDTh5imYwkterx/IqkNQO7KB/
M0wqIK2j4zj4Bpr1ztKaFyEtGjGpXPBQ54V9EHGmGU1jx/Um9PORk3AXyWoUsDf
o0T2Z94FL5UoVUGzUia6/xiUrPCLNf6BLBDGPQg970QtZSU+DYUqjYHzDgv6yXFt
viHARbhZdQIDAQABMA0GCSqGSIb3DQEBQUAA4GBADKF7aIeQ+Uh4Y2zZJw1aIF7
ON+RqDvtyy4DNerEN9iLI4EFO/QJ+uhChZZU8AKR8u3OnLPSntNck330WwMemcOd
QGhnsMtiUq2VuSh+A3Udm+sMLFguCw5RmJvqKTrj3ngAsmDBW3uaK0wkPGp+y3+0
2hUYMf+mCrCOWBEPfs/M
-----END CERTIFICATE-----
```

- Step 3** Copy the certificate text, which is the part in between the BEGIN CERTIFICATE and END CERTIFICATE lines in the output.
- Step 4** Log in to the router CLI.
- Step 5** Configure a certificate for the Central Manager:

```
router#config t
Enter configuration commands, one per line. End with CNTL/Z.
```

```
router(config)#crypto pki trustpoint wcm

router(ca-trustpoint)#enrollment terminal pem
router(ca-trustpoint)#exit
router(config)#crypto pki authenticate wcm
```

Enter the base 64 encoded CA certificate.
End with a blank line or the word "quit" on a line by itself

Step 6 Paste in the certificate that you copied from the Central Manager in Step 3.

Configuring a Router Certificate

The router needs a certificate that is requested by the Central Manager when establishing HTTPS communication. This procedure describes how to configure a persistent self-signed certificate on the router, but you can also use a CA signed certificate.

To configure a router certificate, follow these steps:

-
- Step 1** Log in to the router CLI.
 - Step 2** Create a self-signed certificate on the router:



Note Due to CSCsy03412, you must configure **ip domain name** *name* before enrolling the certificate. If you do not configure **ip domain name**, IOS regenerates the self-signed certificate upon reload and this affects the communication with the WAAS Central Manager.

```
router#config t
Enter configuration commands, one per line. End with CNTL/Z.
router(config)#crypto pki trustpoint local
router(ca-trustpoint)#enrollment selfsigned
router(ca-trustpoint)#subject-alt-name routerFQDN
router(ca-trustpoint)#exit
router(config)#crypto pki enroll local
% Include the router serial number in the subject name? [yes/no]: yes
% Include an IP address in the subject name? [no]: yes
Enter Interface name or IP Address[]: 10.10.10.25
Generate Self Signed Router Certificate? [yes/no]: yes
```

Router Self Signed Certificate successfully created

For an AppNav XE device, if the self signed certificate is generated with key label as hostname and if you change the hostname through the CM GUI or router CLI, then there is a SSL handshake failure and the device goes offline. This is because the existing certificate is a valid only with respect to the old host name and the certificate needs to be validated against the hostname with which it was generated.

To prevent this handshake failure, whenever you change the hostname, you need to re-generate the certificate for that hostname and reimport it.

Additionally, if the router certificate changes after the router is registered with the Central Manager, you must reimport the certificate into the Central Manager. For details, see [Reimporting a Router Device Certificate](#).

Enabling the HTTP Secure Server on the Router

The Central Manager and a router communicate using the HTTPS protocol. You must enable the HTTP secure server on the router.

To enable the HTTP secure server, follow these steps:

Step 1 On the router, enable the HTTP secure server:

```
router#config t  
Enter configuration commands, one per line. End with CNTL/Z.  
router(config)#ip http secure-server
```



Note Be sure to choose the HTTP authentication type that is currently configured on the router. If you choose an HTTP authentication type that differs from your current configuration, your existing configuration on the router will be overwritten and you will not be able to use HTTP to communicate with the router.

Step 2 Configure authentication for the HTTP server for a local user as follows:

```
router(config)#ip http authentication local
```

If you are using external TACACS+ or RADIUS user authentication, configure authentication for the HTTP server as follows:

```
router(config)#ip http authentication aaa
```



Note If you do not configure local or AAA authentication for the HTTP server, only the enable password is used for authentication. (The default is **ip http authentication enable**, which uses only the enable password and no username.) If this default configuration is used, it is not necessary to define a username credential for the router on the Central Manager. (See [Configuring a User](#).)

Installing a License on the Router

The router requires one or more licenses to operate the WAAS Express or AppNav-XE software. Refer to the router documentation for details.

To install a license, follow these steps:

Step 1 Obtain and copy the appropriate license to a location accessible to the **license** command on the router.

Step 2 On the router, install the license:

```
router#license install ftp://infra/licenses/FHH122500AZ_20100811190225615.lic
```

This example uses FTP to get and install the license but there are various options available for this command. Choose one that best suits your deployment.

Step 3 Save the running configuration:

```
router#write memory  
Building configuration...  
[OK]
```

Configuring an NTP Server

It is important to keep the time synchronized between devices in your WAAS network. You should already have an NTP server configured for the Central Manager (see [Configuring NTP Settings](#)).

To configure an NTP server for the router, on the router use the **ntp server** global configuration command, as follows:

```
router#config t
Enter configuration commands, one per line. End with CNTL/Z.
router(config)#ntp server 10.10.10.55
```

Registering the Router

The final step in setting up a router with the Central Manager is to register the device. You will need to know the IP address of the Central Manager.



Note In case of newer releases, router registration using the CLI fails if the router supports only weaker ciphers. You need to either upgrade to a version that supports newer ciphers or register using the WAAS Central Manager GUI.

To register a router with the Central Manager, follow these steps:

Step 1 For a WAAS Express router, register with the Central Manager as follows:

```
router#waas cm-register https://CM_IP_Address:8443/wcm/register
```

If you want to register the WAAS Express router with an IPv6 address, register it as follows:

```
router#waas cm-register https://[CM_IPv6_Address]:8443/wcm/register
```

For an AppNav-XE router, register with the Central Manager as follows:

```
router#appnav cm-register https://CM_IP_Address:8443/wcm/register
```

```
router#appnav cm-register https://[CM_IPv6_Address]:8443/wcm/register
```

In the URL for this command, specify the Central Manager IP address as indicated. Be sure to include a colon and the port number of 8443.

If a permanent WAAS license is not installed on the router, you must accept the terms of the evaluation license to continue. The evaluation license is valid for 60 days.

Step 2 Save the running configuration:

```
router#write memory
Building configuration...
[OK]
```

After the successful registration of the router in the Central Manager, the Central Manager initially shows the device on the Manage Devices page with a management status of Pending and a license status of Active. After the Central Manager retrieves the device configuration and status, the management status changes to Online and the license status changes to Permanent (or Evaluation, Expires in x weeks y days).

Reimporting a Router Device Certificate

If the router device certificate changes after you have registered the router device with the Central Manager, you must reimport a matching certificate into the Central Manager.

To reimport a router device certificate, follow these steps:

-
- Step 1** From the WAAS Central Manager menu, choose **Devices** > *device-name*.
 - Step 2** Choose **Admin** > **Authentication** > **Identity Certificate**. The Certificate window appears
The Certificate Info tab shows the certificate information for the device. The Certificate in PEM Encoded Format tab shows the certificate in PEM format. You can copy the certificate from this tab to use in the paste operation in the next step.
 - Step 3** Import this certificate into the Central Manager by selecting one of the following radio buttons that are shown above the tabs:
 - **Upload PEM file**—Click **Choose File** and locate the PEM file containing the certificate.
 - **Manual**—Paste the PEM-encoded certificate in the text field that appears.
 - Step 4** Click **Submit**.
-

Creating a new WAAS Central Manager IOS user on pre-registered IOS devices

A router that has already been registered with the WAAS Central Manager (WCM) before the system property was enabled needs to be migrated to communicate with the WCM. To enable this communication, you need to create a new WAAS CM IOS user so that the ongoing communication uses the same to communicate with the WCM.

The WAAS Express User Creation Tool window is visible only when the System.WcmIosUser.enable is enabled on the **Home** > **Configure** > **System Properties** > **WcmIosUser**.

To create a new WAAS Central Manager IOS user on the registered IOS device, follow the steps:

-
- Step 1** From the WAAS Central Manager menu, choose **Home** > **Admin** > **Security** > **WCM Cisco IOS User Creation Tool**. The WAAS Express User Creation Tool window appears.
 - Step 2** Configure the router login credentials by entering the username, password, and enable.
 - Step 3** Select the Router IP address type - IPv4 or IPv6. Next select the Router IP Address entry method. In the IP Address(es) field, enter the WAAS Express router IP addresses to migrate, separated by commas. The IP address, hostname and status are displayed in the Status table.
You may also upload a CSV file that contains a list of IP addresses to migrate. To upload a list, click the Upload File check box and click the Choose File button to browse to the file and click Open. Each IP address must be on a separate line.

- Step 4** Click the Update button to create a new WAAS CM IOS user on the router and verify that the user creation status was successful.

In case you want to migrate additional pre-registered routers, use the Reset button to clear data from all the fields, to enter the next configuration.

If you create a Cisco IOS WCM user, using the **Home > Admin > Security > WCM Cisco IOS User Creation Tool** by specifying the Cisco IOS username, password and enable, you need to manually log in to the Cisco IOS router and save the running configuration using the **write memory EXEC** command.

If you do not save the running configuration and reload the device, the Cisco IOS router goes off line in the WAAS Central Manager.

WAAS, ISR-WAAS, and IOS-XE Interoperability

Follow these operating guidelines for WAAS, ISR-WAAS and IOS-XE Interoperability:

- ISR4321-B/K9 is not supported for ISR-WAAS installation.
- **Activating ISR-WAAS after formatting the Cisco 4000 Series ISR-router bootflash:**
After you format the Cisco 4000 Series ISR-router bootflash, you must reload the router to ensure a successful activation of ISR-WAAS. If you do not reload the ISR router after formatting the bootflash, you will be unable to activate ISR-WAAS. For more information on formatting the Cisco 4000 Series ISR router bootflash, see the [Configuration Guide for Integrated AppNav/AppNav-XE and ISR-WAAS on Cisco 4000 Series ISRs](#).
- **For ISR-4321 with IOS-XE, used with WAAS Version 6.2.3c or 6.3.1:**
You must complete a new OVA deployment of WAAS version 6.2.3c or 6.3.1 for this configuration to work successfully. This configuration will not automatically work after an upgrade to WAAS Version 6.2.3c or 6.3.1 from WAAS Version 5.x or 6.x.
- **Using the intrusion detection and prevention system Snort with ISR-WAAS and ISR-4000 Series, with a hard disk less than or equal to 200 GB:**
To ensure a successful WAAS installation of ISR-WAAS and Snort on an ISR router, you must install ISR-WAAS *before* you install Snort. If you do not follow this installation order, ISR-WAAS will not install and a disk error will be displayed.
- **VRF restriction for VirtualPortGroup31 on ISR-WAAS:**
When you configure ISR-WAAS with EZConfig—VirtualPortGroup31, the WAAS service/router interface, is automatically created, and you can then add or modify specific parameters for it.



Note Do not add Virtual Routing and Forwarding (VRF) to VirtualPortGroup31. VRF will cause VirtualPortGroup31 to lose its IP address and will disable AppNav. To re-establish these, you must uninstall and reinstall ISR-WAAS without VRF.

For more information on VirtualPortGroup31, see the [Configuration Guide for Integrated AppNav/AppNav-XE and ISR-WAAS on Cisco 4000 Series ISRs](#).

Configuring the Hostname for ISR-WAAS

This section contains the following topics:

- [About ISR-WAAS and ISR-WAAS Hostname](#)
- [Configuring an ISR-WAAS Hostname with the Cisco WAAS CM](#)
- [Configuring the ISR-WAAS Hostname with the CLI](#)
- [Resetting an ISR-WAAS Hostname](#)

About ISR-WAAS and ISR-WAAS Hostname

ISR-WAAS is a virtualized WAAS instance running on a Cisco ISR router. It provides added optimization without the need for additional hardware or external appliances.

For WAAS v5.5.5 and later, you can configure the ISR-WAAS hostname. (For WAAS versions 5.5.1 and earlier, ISR-WAAS receives a system-generated hostname from the ISR-Router, which cannot be edited.)

Consider the following guidelines for the ISR-WAAS hostname:

- The ISR-WAAS hostname is independent of the ISR Router hostname. Changing the ISR Router hostname does not change the ISR-WAAS hostname.
- Hostname configuration is not supported on the ISR-WAAS device when it is downgraded from software version 6.x to a version lower than 5.5.5.
- Each ISR-WAAS image is shipped with multiple profiles, as shown in [Table 10-6](#). Each profile dictates the resources used by the ISR-WAAS virtual instance and the number of connections supported. The default is the profile with the highest number of connections; you can select the profile that meets the requirements of your system.



Note To change the ISR-WAAS profile of an active ISR-WAAS, you must first de-install and then re-install the ISR-WAAS.

If you only de-activate the existing ISR-WAAS instance and then change the ISR-WAAS profile, the ISR-WAAS will become unstable and the TFO limit will show Zero on the ISR-WAAS console.

Table 10-6 Cisco ISR-4451-X Requirements for ISR-WAAS

ISR-WAAS	Router DRAM (GB)	SSDs (200GB each)	Compact Flash (GB)
ISR-WAAS-750	8	1	16
ISR-WAAS-1300	16	1	16
ISR-WAAS-2500	16	2	32

For information on how to deploy and register an ISR-WAAS, see the [Configuration Guide for Integrated AppNav/AppNav-XE and ISR-WAAS on Cisco ISR 4451-X](#).

Configuring an ISR-WAAS Hostname with the Cisco WAAS CM

To configure the ISR-WAAS hostname with the Cisco WAAS CM, follow these steps:

-
- Step 1** Verify that the ISR-WAAS device is online by choosing `Devices > device-name`.
The Device Dashboard window appears, and displays information including device status: Pending, Installed, Online, or Inactive.
-  **Note** During a fresh OVA deployment of an ISR-WAAS instance, the ISR-WAAS default hostname is `router-name isr-waas`. After the hostname is changed on the kwaas instance, the kwaas instance does not get an update from the router until you change it in the kwaas instance with the CLI command `no-hostname`.
-
- Step 2** To change the ISR WAAS hostname, choose `Devices > ISR WAAS Device > Activation`.
The Device Activation appears, with fields for editing properties of the selected device. The Name field initially has the default ISR-WAAS hostname, `router-hostname-isr-waas`.
- Step 3** In the Name field of the Activation window, enter the new name of the ISR-WAAS hostname. A maximum of 30 alphanumeric characters, including a hyphen, can be entered. The hostname is case sensitive. Special characters such as \$, #, or * are not allowed.
- Step 4** Click **Submit**.
- Step 5** To verify that the new hostname is saved, click the `show hosts` command.
-

Configuring the ISR-WAAS Hostname with the CLI

To configure the hostname for an ISR-WAAS using the IRS router CLI, follow these steps:

-
- Step 1** Use the router CLI command `show virtual-service list` to verify that the ISR-WAAS device is online.
The `show virtual-service list` displays the status for each device, as shown in [Figure 10-1](#). Possible states are Initializing, Installing, Installed, Install Failed, Activating, Activated, Activated Failed, Deactivating, Deactivated, and Error.

Figure 10-1 Sample `show virtual-service list` Output

```
router# show virtual-service list

Virtual Service List:
Name                Status                Package Name
-----
multiova            Activated             multiova-working.ova
WAAS                Installed             ISR4451X-WAAS-5.5.5...
```

- Step 2** Log in to the ISR-WAAS device.
- Step 3** Enter Configuration mode and use the router global configuration command `hostname hostname` to specify a new hostname. A maximum of 30 alphanumeric characters, including a hyphen, can be entered. Special characters such as \$, #, or * are not allowed.

```
Router# config
Router (config)# hostname isr-waas-rs4a
```

Step 4 Use the **show hosts** command to verify that the new ISR-WAAS hostname has been saved.

Resetting an ISR-WAAS Hostname

Use the **restore factory default** command to reset an ISR-WAAS hostname. However, note the different results generated by the **restore factory default** command and its parameters:

- To reset the ISR-WAAS hostname to its factory default (*-ISR-WAAS*), use the **restore factory-default** command. This version of the command resets the entire device configuration and all data back to the manufacture factory status.
- To retain the ISR-WAAS hostname but reset other parts of the device configuration and data, use the **restore factory-default preserve basic-config** command. This version of the command resets all device configuration and all data back to the manufacture factory status, but preserves the ISR-WAAS hostname, as well as domain name, name server, and network interfaces.

For more information on using the **restore factory-default** command, see the [Cisco Wide Area Application Services Command Reference Guide](#).



PART 2

Configuring Cisco WAAS Services



Configuring File Services

This chapter describes how to configure file services, which allows branch office users to access data stored at centralized data centers more efficiently. The file services feature overcomes the WAN latency and bandwidth limitations by caching data on Edge Wide Area Application Engines (WAEs) near branch office users. Cisco Wide Area Application Services (WAAS) file services use Server Message Block (SMB) application accelerators.



Note

Throughout this chapter, the term Cisco WAAS device is used to refer collectively to the Cisco WAAS Central Managers and WAEs in your network. The term WAE refers to WAE and Cisco Wide Area Virtualization Engine (WAVE) appliances Cisco Services Ready Engine (Cisco SRE) service modules (SRE-SM) WAAS, and Cisco Virtual WAAS (vWAAS) instances.

This chapter contains the following sections:

- [About File Services](#)
- [Overview of the File Services Features](#)
- [Preparing for File Services](#)
- [Configuring File Services](#)

About File Services

Enterprises today have remote offices in different parts of the country and around the world. Typically, these remote offices have their own file servers to store and manage the data needed by their local users.

The problem with this method of operation is that it is costly to purchase, manage, and upgrade file servers at each remote office. A great deal of resources and manpower must be dedicated to maintaining these file servers, especially to protect the data in case of server failure. To achieve the required level of data assurance, the remote office must devote resources to back up the data at the remote site and physically move it to a secure location, often at a considerable distance from the site. If you multiply this scenario by tens, hundreds, and thousands of remote offices, you can see that this approach to enterprise data management not only raises costs exponentially, it also greatly increases risks to critical data.

The logical solution is to move all of the enterprise's important data to a central location containing the facilities, trained personnel, and storage mass required to manage the data properly. By having a data center provide backup and other storage-management facilities, the enterprise can achieve better utilization of both personnel and storage, as well as a higher level of data assurance and security.

The WAN between the enterprise's data center and its remote offices tends to be unreliable and slow, with limited bandwidth and high latency. In addition, the WAN creates other obstacles to the implementation of the data center solution.

One obstacle is created by the file server protocols that operate over the WAN. Every file operation generates several exchanges of protocol messages between the client and the file server. This situation is usually not noticeable on the LAN, but quickly causes high latency over the WAN. Occasionally, this high latency breaks the file server protocol altogether.

Even in cases where the file server protocol is able to function correctly over the WAN, there are typically long delays between each transaction. These delays can often cause timeouts in user applications such as word-processing programs, image-editing programs, and design tools, which stops applications from functioning correctly.

All of these problems—unreliable WANs, file system protocol compatibility, and user application compatibility—contribute to an unfriendly work environment that negatively affects the user experience and diminishes productivity.

The WAAS File Services feature overcomes WAN latency and bandwidth limitations by caching data on Edge WAEs near the user. This data caching method allows branch office users to access centralized data at LAN-like speeds over the WAN. The solution is based on several key concepts:

- Use the WAN as little as possible—By minimizing the number of operations that need to traverse the WAN, WAAS effectively shields users from many of the obstacles that WANs create.
- Use the WAN optimally—The File Services feature uses sophisticated caching, compression, and network optimization technologies, which enable the system to use the WAN optimally.
- Preserve file system protocol semantics—Although WAAS software uses its own proprietary protocol over the WAN, it leaves the complete semantics of the standard file system protocol commands intact. This is essential to preserve the correctness and coherency of the data in the network.
- Make the solution transparent to users—The best solutions are the ones that do their jobs unnoticed, without interfering with end users' operations or forcing users to change their ways of doing business. The WAAS file services solution does not require any software installations, either on the server side or at the client-side, and does not require a user to learn anything new. Users derive all the benefits of having a secure data center without needing to change any of their work habits.

By using the WAAS File Services feature, enterprises can consolidate their file servers to a data center that provides the facilities, IT personnel, and storage devices required to manage the data properly.

[Figure 11-1](#) shows a typical deployment scenario after WAAS file services have been set up.

Figure 11-1 WAAS File Services Solution

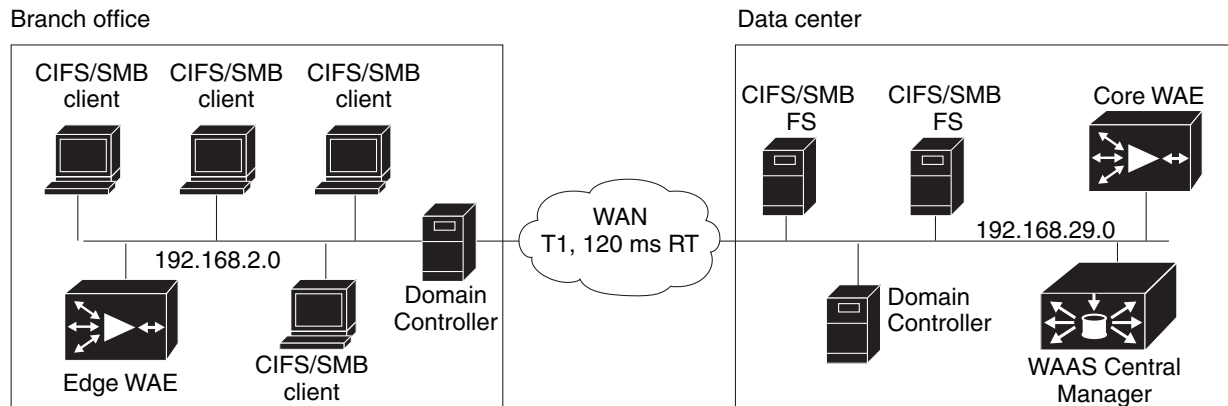

Overview of the File Services Features

This section provides an overview of the WAAS File Services features and contains the following topics:

- [Automatic Discovery](#)
- [Data Coherency](#)
- [Prepositioning](#)
- [Data Concurrency](#)
- [Microsoft Interoperability](#)

To accelerate SMB traffic, you can use the following accelerator:

- **SMB**—The SMB accelerator, introduced in WAAS Version 5.0.1, relies on automatic discovery, transparently accelerates traffic, support prepositioning of files. This accelerator has configuration options that you can fine-tune for specific needs.

This accelerator supports the SMB 1.0, 2.0, and 2.1 protocols for signed SMB traffic.



Note

Legacy-mode Cisco Wide Area File Services (WAFS) is no longer supported beginning with WAAS Version 4.4.1. Legacy WAFS users must migrate to the SMB accelerator before upgrading.

Automatic Discovery

The automatic discovery feature allows you to enable SMB without having to register individual file servers in the WAAS Central Manager. With the automatic discovery feature, WAAS attempts to automatically discover and connect to a new file server when a SMB request is received.

Data Coherency

WAAS software ensures data integrity across the system by using two interrelated features – *coherency*, which manages the freshness of data, and *concurrency*, which controls the access to data by multiple clients.

Maintaining multiple copies of data files in multiple locations increases the likelihood that one or more of these copies will be changed, causing it to lose consistency or coherency with the others. Coherency semantics are used to provide guarantees of freshness (whether the copy is up-to-date or not) and the propagation of updates to and from the origin file server.

The WAAS software applies the following coherency semantics to its built-in coherency policies:

- **Strict SMB behavior for intra-site**—Users of the same cache are always guaranteed standard, strict SMB coherency semantics.
- **Cache validation on SMB open**—In SMB, the File Open operation is passed through to the file server. For coherency purposes, WAAS software validates the freshness of the file on every file that is open, and invalidates the cached file if a new version exists on the file server.

WAAS software validates data by comparing the time stamp of a file in the cache to the time stamp of the file on the file server. If the time stamps are identical, the cached copy in the Edge WAE is considered valid, and the user is permitted to open the file from the Edge WAE cache.

If the time stamps are different, the Edge WAE removes the file from its cache and requests a fresh copy from the file server.

- **Proactive cache updating**—WAAS software supports the use of change notifications in SMB environments as a way to keep cached data on the Edge WAEs up-to-date.

When a client makes a change to a directory or file, the Edge WAE sends a change notification to the file server. The file server then sends a change notification to all the Edge WAEs, which includes a list of the modified directories and files. Upon receiving the change notification, each Edge WAE checks its cache and invalidates the directories and files listed in the notification, and then updates its cache with the latest versions.

For example, if a user edits an existing Word document and saves the changes to the Edge WAE cache, the Edge WAE sends a change notification to the file server so that it knows that the file has been modified. The Edge WAE then sends the changed sections to the file server, and the file server proactively sends change notifications to the other Edge WAEs in the network. These Edge WAEs then update their cache so that the file is consistent across all access points.

This process is also applicable when you rename a directory, add a new subdirectory, rename a file, or create a new file in a cached directory.

- **Flush on SMB close**—In SMB, the File Close operation forces all the write buffers to be flushed to the file server, and the Close request is only granted after all the updates have been propagated to the file server. From a coherency standpoint, the combination of validate on file open and flush on file close ensures that well-behaved applications, such as Microsoft Office, operate in session semantics. The Open, Lock, Edit, Unlock, and Close commands are guaranteed to work correctly on the WAAS network.

This authorization process prevents users from accessing directories and files in the cache that they do not have permission to access on the file server.

Data Concurrency

Concurrency control is important when multiple users access the same cached data to read, or write, or both. Concurrency control synchronizes this access by establishing and removing file system locks. This file-locking feature ensures data integrity and provides the following benefits:

- Enables a client to aggressively cache file data so that it does not have to rely on retrieving data from the remote file server.
- Provides a performance boost in many applications running on existing CIFS client implementations.
- Preserves data integrity because only one user at a time can make changes to a section of a file.

WAAS software supports the CIFS oplocks feature, which allows a user to lock a file so that the user can safely read and write data to its local cache instead of using network bandwidth to perform these functions over the WAN on the file server. By using oplocks, a user can proactively cache read-ahead data because it knows that no other user is accessing the file, and therefore, there is no chance of the cached data becoming stale. The user can also write data to its local cache and does not have to update the file server until it closes the file or until another user requests that the same file be opened.

Oplocks only applies to files. The file server does not grant oplock requests on directories and named pipes.

File-Locking Process

When a user opens a file, it sends a lock request to the file server. The Edge WAE intercepts and forwards all lock requests from the user to the file server as well as all the responses from the file server to the user. If no other user has a lock on the file, the file server grants an exclusive lock request so that the user can safely cache the file.

If a second user requests that the same file be opened, the following actions occur:

- The file server revokes the exclusive file lock obtained by the first user.
- The first user performs the following actions:
 - Flushes any file changes stored in its cache to the file server. This action ensures that the second user opening the file receives the latest information from the file server.
 - Deletes any of its read-ahead buffers for the file because that data is no longer guaranteed to remain up-to-date since a second user will open the file.
- The file server allows the second user to open the file.

Prepositioning

**Note**

Only the CIFS accelerator supports prepositioning.

The prepositioning feature allows system administrators to proactively *push* frequently used files from the central storage into the cache of selected Edge WAEs. This operation provides users with faster first-time file access, and makes more efficient use of available bandwidth. You can create preposition directives from the WAAS Central Manager GUI.

When an end user attempts to open a file that is not found in the Edge WAE cache, the Edge WAE retrieves it across the WAN from the file server where it is stored. Prepositioning is a feature that allows administrators to push large, frequently accessed files from file servers to selected Edge WAE caches according to a predefined schedule. Through the proper use of prepositioning, administrators can allow users to benefit from cache-level performance even during first-time access of these files. Prepositioning improves WAN bandwidth utilization by transferring heavy content when the network is otherwise idle, for example, at night, which frees up bandwidth for other applications during the day.

The WAAS Central Manager GUI allows administrators to create multiple, overlapping preposition policies (each with its own schedule), a list of target Edge WAEs, and defined time and size constraints.

Prepositioning includes the ability to configure multiple roots. See [Creating a New Preposition Directive](#).

Preparing for File Services

Before enabling file services on your WAEs, ensure that you complete the following tasks:

- If you want to configure multiple devices with the same settings, ensure that you have created a device group that contains all the devices you want to enable with file services. For information on creating device groups, see [Chapter 3, “Using Device Groups and Device Locations.”](#)
- Identify the file servers that you want to export, and refer to [Table 11-1](#) to verify that these file servers can operate with WAAS software.



Note

Other file servers may operate with WAAS, but only those listed in the table were tested. The file server must support opportunistic locking (oplocks) and CIFS notifications.



Note

The CIFS application accelerator does not support file servers that use the FAT32 file system. You can use the policy rules to exclude FAT32 file servers, if any, from CIFS accelerator optimization.



Note

Certain combinations of operating systems and file systems on a file server can result in the server responding with different timestamp precision for different SMB commands. In such a situation, you may not get the highest possible CIFS optimization if the CIFS application accelerator avoids using cached files with mismatched timestamps in favor of preserving data coherency.

Using File Services on the Cisco WAAS Network Module (NME-WAE)

If you are running WAAS on a network module that is installed in a Cisco access router, there are specific memory requirements for supporting file services. The NME-WAE must contain at least 1 GB of RAM to support file services:

If you try to enable file services and the device does not contain enough memory, the WAAS Central Manager will display an error message.

You can check the amount of memory that a device contains in the Device Dashboard window. For details, see [Device Dashboard Window](#) of Chapter 14, “Monitoring Your WAAS Network.”

Configuring File Services

To accelerate CIFS traffic, you can enable and configure the CIFS accelerators, as described below.

Configuring the CIFS Accelerator

The CIFS accelerator relies on automatic discovery and transparently accelerates CIFS traffic with no configuration needed.

[Table 11-1](#) provides an overview of the steps that you must complete to configure the CIFS accelerator.

Table 11-1 Checklist for Configuring CIFS Accelerator

Task	Additional Information and Instructions
1. Prepare for file services.	Provides the tasks that you need to complete before enabling and configuring file services on your WAAS devices. For more information, see Preparing for File Services .
2. Enable SMB acceleration.	Enables and configures the SMB accelerator. For more information, see Enabling and Disabling the Global Optimization Features of Chapter 12, “Configuring Application Acceleration.”
3. (Optional) Identify dynamic shares.	Identifies the dynamic shares on an exported file server. If your file server uses Access Based Enumeration (ABE) to give users different views of the share, you must configure the dynamic shares on the WAAS Central Manager. For more information, see Creating Dynamic Shares for the CIFS Accelerator
4. (Optional) Create a preposition directive.	Defines which files are proactively copied from an exported file server to the Edge WAE cache. For more information, see About Preposition Directives section.

Creating Dynamic Shares for the CIFS Accelerator

Many file servers use dynamic shares, that is, multiple users can access the same share, but the share is then automatically mapped to a different directory based on a user’s credentials. Dynamic shares are most commonly used on file servers to set up user home directories. For example, a directory named Home can be set up as a dynamic share on a file server so that each user accessing that share is automatically redirected to their own personal directory.

If a file server contains a dynamic share or is using Access Based Enumeration (ABE), you must register that dynamic share with the WAAS Central Manager, as described in this section.

Defining a dynamic share in the WAAS Central Manager allows each user to see a different view of the share and allows the operation of ABE if it is configured on the Windows Server.



Note

Dynamic share configuration on the WAAS Central Manager overrides any dynamic share configuration set up directly on the WAE device using the CLI.

Before adding a dynamic share, note the following limitations:

- Each dynamic share on a file server must be unique.
- You cannot add a dynamic share if that share has a preposition directive. You must remove the preposition policy before you can add the dynamic share.
- You can use the WAAS Central Manager GUI to define any directory as a dynamic share. However, if a directory is not set up as a dynamic share on the file server, all the users will read or write the same content from the same directory and will not be redirected to different directories based on their credentials.

To add a dynamic share for the CIFS accelerator, follow these steps:

Step 1 From the WAAS Central Manager menu, choose **Configure > CIFS File Services > Dynamic Shares**.

A list of dynamic shares appears. The Dynamic Shares window shows all the dynamic shares that are configured. From this window, you can perform the following tasks:

- Edit the configuration of an existing dynamic share by clicking the **Edit** icon next to the share. You can delete a dynamic share, or modify any of the dynamic share settings.
- Add a new dynamic share definition.

Step 2 Click the **Create New Dynamic Share** icon in the taskbar to add a new dynamic share.

The Creating a new Dynamic Share window appears.

Step 3 In the Name field, enter a name for the dynamic share.

The following characters are not supported in the dynamic share name: /, \, :, *, ?, ", <, >, |. From the Assigned Domain drop-down list, choose the WAAS domain that you want to assign to the dynamic share. Only administrators who are also assigned to this WAAS domain have permission to edit the dynamic share configuration. The domain does not affect a client's access to the dynamic share.



Note A WAAS domain is not the same as a DNS domain or Windows domain. For more information on WAAS domains, see [Working with Domains](#).

This kind of WAAS domain does not use entities. When defining the WAAS domain, choose **None** for the Entity Type. The WAAS domain must be assigned to each WAAS admin user who needs to edit the dynamic share configuration (see [Assigning a Domain to a User Account](#)).

Step 4 In the File Server field, enter the name or IP address of the file server with the dynamic share.

If you specify the file server name, the Edge WAE resolves it to an IP address.

The registered file servers are displayed in a drop-down list.

Step 5 In the User name, Password, and Confirm Password fields, enter the username and password credentials for the file server. If the username is in a Windows domain, specify the domain name as part of the User name field, as follows: domain\username.

These credentials are used only to access the file server when you click **Browse**.

Step 6 In the Share Name field, specify the location of the dynamic share by doing one of the following tasks:

- Enter the name of the dynamic share on the file server. The following characters cannot be used in the share name: \, /, :, *, ?, ", <, >, |.
- Click **Browse** next to the **Share Name** field to navigate to the correct root directory.



Note The Browse button appears only if you have at least one WAE device with the CIFS accelerator enabled and registered to the WAAS Central Manager.

- Step 7** Ensure that the status of the share is set to Enabled. If you change the status to Disabled, the share will not be set up as a dynamic share in your WAAS environment.
- Step 8** Click **Submit**.
- The specified directory now functions as a dynamic share on the Edge WAE cache.
-

About Preposition Directives

A preposition directive allows you to determine which files should be proactively copied from CIFS file servers to the cache of selected Edge WAEs. Prepositioning enables you to take advantage of the idle time on the WAN to transfer frequently accessed files to selected WAEs, where users can benefit from cache-level performance even during first-time access of these files.

Prepositioning is supported on automatically discovered file servers in the transparent CIFS accelerator.

When defining a preposition directive, select the Edge WAEs that you want to be prepositioned with content from the file server, and then specify the root directories on the file server to be prepositioned. Initially, the preposition directive is in the unscheduled state. You must create a schedule that determines when and how often the content is prepositioned. Because content can be prepositioned on a regular basis, you can specify whether each new iteration of the task should copy all designated files, or only those files that have changed over a specified time interval.

In addition, you can specify time and size limits to prevent a preposition task from consuming too much bandwidth on the WAN or too much space on the Edge WAE cache. We strongly recommend that you use these limits to optimize network efficiency and prevent misuse of this feature.

When the activation time of a preposition directive arrives, a preposition task starts on the Edge WAE. Each preposition task can be monitored in the WAAS Central Manager GUI during and after processing. You can also terminate active preposition tasks, if required.

Prepositioning requires that the username and password needed to access the file server be specified. These items are specified directly in the Creating New Preposition Directive window, as described in [Creating a New Preposition Directive](#).



Note

When preposition updates are sent to the Central Manager, if any preposition file server credentials cannot be decrypted, all further preposition updates are not sent from the WAE to the Central Manager, and decryption failure error messages are logged in `errorlog/cms_log.current`. You must reconfigure the preposition credentials from the CLI.

Prepositioning includes the ability to configure multiple roots. See [Creating a New Preposition Directive](#).

When using prepositioning, both branch and data center WAEs are required (the same as for any other accelerated traffic). The branch WAE retrieves prepositioned files through an optimized connection. Verify that you have connectivity between the following network entities:

- Client to branch WAE
- Branch WAE to data center WAE
- Branch WAE to file server
- Data center WAE to file server

You will need to change any ACLs that might be blocking prepositioning traffic.

**Note**

Although preposition directives can be created and managed by using the CLI, we recommend that you use the Central Manager GUI because you can manage prepositioning for groups of WAEs from the Central Manager. If you mix GUI and CLI configuration, unpredictable results may occur because changes on one device can affect other devices.

The following topics describe how to create and manage a preposition directive:

- [Creating a New Preposition Directive](#)
- [Assigning Edge Devices to a Preposition Directive](#)
- [Creating a New Preposition Schedule](#)
- [Checking the Preposition Status](#)
- [Starting and Stopping Preposition Tasks](#)

Creating a New Preposition Directive

To create a preposition directive, follow these steps:

Step 1 From the WAAS Central Manager menu, choose **Configure > CIFS File Services > Preposition**.

The Preposition Directives window appears. This window displays the following information about preposition directives that exist on the system:

- Preposition Directive—Name of the preposition directive.
- Type—Whether the preposition directive affects all files (Full) or just those that have changed since the last preposition task (Differential).
 - When the type is Full, all the files that match the other filters of the task and that are found on the file server are sent to the Edge to be compared with the cache.
 - When the type is Differential, only the files that are found as changed since the last successful preposition are sent to the Edge cache. The time of the last successful preposition is taken from the Edge device, so ensure that the clock is synchronized with the file server. The first scan is always a full scan. If you change the preposition task, the last successful scan time is reset.
 - When the type is Since, only the files that are found as changed within a specified time period are sent to the Edge cache.
- Status—Whether the preposition directive is enabled or disabled.
- File Server—Name of the exported file server.

From the Preposition Directive window, you can perform the following tasks:

- Edit the configuration of an existing preposition directive by clicking the **Edit** icon next to the corresponding directive. You can then delete the preposition directive, or modify any of the settings.
- Add a new preposition directive, as described in the following steps.

Step 2 Click the **Create New Preposition Directive** icon in the taskbar to create a new preposition directive.

The Creating New Preposition Directive window appears. ([Figure 11-2](#))

Figure 11-2 Creating a New Preposition Directive Window

- Step 3** Enter a unique name for the directive. The name cannot contain characters other than letters, numbers, period, hyphen, and underscore; the double quote (") character is not allowed in the name.
- Step 4** From the Status drop-down list, choose either **enabled** or **disabled**. (Disabled directives are not put into effect.)
- Step 5** (Optional) Define the time and size limitations using the provided fields.



Note Table 11-3 describes the time and size limitation fields. If one of these limits is exceeded during a prepositioning task, the task is terminated and a message is sent to the Administrator log. Any remaining files are exported the next time the task is run. If a user requests one of the missing files before this happens, it is fetched over the WAN through WAAS software as usual.

- Step 6** (Optional) Check the **Ignore Hidden Directories** check box if you want to prevent hidden directories on the file server from being prepositioned. This check box is unchecked by default. If you leave this box unchecked, hidden directories are prepositioned.
- Step 7** In the File Server field, enter the unique name of a file server to export. The name cannot contain characters other than letters, numbers, period, hyphen, and underscore; the double quote (") or forward slash (/) characters are not allowed in the name.

Step 8 From the Location drop-down list, choose the device location that will provide browsing services for the file server. Normally, this is the data center WAE. For the best browsing performance, specify a location that is close to the file server. The location is used only for browsing; each edge WAE will retrieve prepositioned files directly from the file server, not from this location. For more information on defining locations, see [Working with Device Locations](#).

Step 9 In the User name, Password, and Confirm Password fields, enter the username and password credentials for the file server. If the username is in a Windows domain, specify the domain name as part of the User name field, as follows: domain\username.

The access credentials that you enter must allow read access to the prepositioned root directories and to their parent directories.

Step 10 (Optional) Check the **DSCP value for high priority messages** check box if you want to assign a DSCP marking value to the prepositioning traffic. Choose a DSCP value from the drop-down list or enter a number from 0 to 63 in the text field.

DSCP is a field in an IP packet that enables different levels of service to be assigned to the network traffic. Levels of service are assigned by marking each packet on the network with a DSCP code and associating a corresponding level of service. DSCP is the combination of IP Precedence and Type of Service (ToS) fields. For more information, see RFC 2474.

Step 11 In the Root Share and Directories field, enter the directories on the file server that you want to export. Use any of the following methods to identify a directory:

- Manually enter one or more directory paths in the following format: *protocol://server/share* or *server\share*, for example, *cifs://win12srv/home* or *win12srv\home*. You can enter multiple lines for multiple directories, with each full directory path on its own line. You cannot specify the root directory (*/*) as a root share.

When you define multiple root shares, the preposition sequence that is performed for a single root configuration is repeated for each root serially.

- Click **Browse** to browse the directories on the file server. To navigate to a directory, click the File Folder icon to the left of the directory name. Check the check box next to the directory that you want to export and then click **Select Directory**. The browse window allows you to choose multiple directories.

The browse function operates best when you choose the location of the nearest CIFS accelerator to the file server, from the Location drop-down list. If you do not choose a location, the browse request is sent to all the devices that have the CIFS accelerator enabled, and the request may time out.

- Check the **Include Sub Directories** check box to include all the subdirectories under the specified root directory. If this option is not selected, only the files in the specified root directory are prepositioned and you cannot select subdirectories when you are browsing.
- Narrow the policy definition to a particular type of file by choosing a pattern operator from the File Name drop-down list and entering the text that describes the pattern in the adjacent text box, for example, enter **ends with .doc**. Do not use a space or the following special characters:
|, :, >, <, ", ?, *, /, \.

Step 12 Click **Submit**.

The directive is saved and additional tabs appear at the top of the window.

Assigning Edge Devices to a Preposition Directive



After you create a preposition directive, you need to assign Edge WAEs or device groups to the directive. This task determines which Edge WAEs will store-preposition content in their cache.



Note

Prepositioning includes the ability to configure multiple roots. See [Creating a New Preposition Directive](#).

To assign an Edge WAE or device group to a preposition directive, follow these steps:

- Step 1** From the WAAS Central Manager menu, choose **Configure > CIFS File Services > Preposition**. The Preposition Directives window appears, which lists the preposition directives that exist on the system.
- Step 2** Click the **Edit** icon next to the preposition directive that you want to assign to an Edge WAE or device group.
- Step 3** Click one of the following tabs at the top of the window:
- **Assign Edge Devices**—Allows you to select one or more Edge WAEs to assign to this directive.
 - **Assign Edge Groups**—Allows you to select a device group to assign to this directive.
- The Edge Device Assignments window or the Device Groups Assignments window appears, depending on the selected option.
- For either view, the assignments window lets you filter your view of the items in the list. Filtering enables you to find items in the list that match the criteria that you set.
- Step 4** Choose the Edge WAEs or device groups to assign to this preposition directive by doing either of the following:
- Click  (Assign All) in the taskbar to assign all the available Edge WAEs or device groups to this directive.
 - Click  next to the individual Edge WAE or device group that you want to assign to this directive. The icon changes to  when selected.



Note

If a device or device group is offline (identified by ) , then you cannot assign that device or group to this directive. The preposition directive, when assigned to a device group, is applied only to connected Edge devices in the assigned device group.

When assigning a CIFS accelerator preposition directive to a device group, the directive is applied only to those devices enabled for CIFS acceleration in the assigned device group.

- Step 5** Click **Submit**.

The icon next to each edge device or device group you selected changes to  .



Note

If the CIFS accelerator is disabled on a WAE, the WAE is removed from any preposition directives to which it is assigned. Also, the preposition directive is removed from the device's running configuration.

Creating a New Preposition Schedule

After you create a preposition directive and assign WAEs to the directive, we recommend that you create a schedule that determines when and how often prepositioning occurs.

For example, you may want to schedule prepositioning to occur at night to minimize the amount of traffic during business hours, or, you may want to schedule prepositioning to occur on a recurring basis if the exported data changes often. This will help ensure that the WAEs assigned to this directive have the latest file updates in their cache.

When a preposition task is scheduled to begin at the same time for multiple Edge WAEs that are located in different timezones, the task will begin on the Edge WAEs based on the Core WAE timezone. If the clocks of the Edge WAE and the Core WAE are not synchronized, the task will not start on time.

To create a preposition schedule, follow these steps:

-
- Step 1** From the WAAS Central Manager menu, choose **Configure > CIFS File Services > Preposition**. The Preposition Directives window appears, which lists the preposition directives that exist on the system.
- Step 2** Click the **Edit** icon next to the preposition directive for which you want to create a schedule.
- Step 3** Click the **Schedule** tab at the top of the window. The Creating New Preposition Schedule window appears. By default, no schedule is configured.
- Step 4** Choose one of the following scheduling options:
- **Not Scheduled**—Prepositioning is not scheduled at this time.
 - **Now**—Prepositioning occurs within a few minutes after you submit this schedule.
A Now schedule begins again each time you make a change to the preposition directive and click **Submit** button.
A Now schedule also begins again as soon as an Edge device that has been reloaded comes back online.
 - **Daily**—Prepositioning occurs daily at the defined time.
 - **Date**—Prepositioning occurs at the defined time and date.
 - **Weekly**—Prepositioning occurs on the selected days of the week at the defined time.
 - **Monthly Days**—Prepositioning occurs on the selected days of the month at the defined time.
 - **Monthly Weekdays**—Prepositioning occurs on the defined day (as opposed to a defined date) and time during the month. For example, you can schedule prepositioning to occur on the second Tuesday of every month.
- Step 5** Specify a start time for the prepositioning task.
The time is expressed in 24-hour format with 00:00 representing midnight. The time refers to the local time of the Edge WAE where the data is to be prepositioned. If there are multiple Edge WAEs in different time zones, the time refers to the local time of the Core WAE.
-
-  **Note** You cannot schedule a start time for the **Now** option.
-
- Step 6** Click **Submit**.
The message Changes Submitted appears at the bottom of the window confirming that your schedule was saved.

- Step 7** Verify that the preposition directive has completed successfully by checking the preposition status. For more information, see [Checking the Preposition Status](#).

Checking the Preposition Status

After you create one or more preposition directives, you can verify the status of all the preposition tasks to ensure that they are completed successfully. If a task does not complete successfully, then some of the prepositioned files may have not been copied to the Edge WAE cache.

To check the status of a prepositioning task, follow these steps:

- Step 1** From the WAAS Central Manager menu, choose **Configure > CIFS File Services > Preposition**.

The Preposition Directives window, which lists the preposition directives that exist on the system, appears.

- Step 2** Click the **Edit** icon next to the preposition directive that you want to check.

- Step 3** Click the **Preposition Status** tab at the top of the window.

The Preposition Status window displays the following information:

- **WAE**—The name of each Edge WAE that received the prepositioned files in its cache.
- **Start Time**—The time the preposition task started.
- **Duration**—The amount of time it took the preposition task to be completed.
- **Amount Copied**—The amount of data copied to the WAE cache, in bytes.
- **Status**—Whether the preposition task is completed successfully.
- **Reason**—The reason a preposition task failed.

- Step 4** Ensure that the Status column shows Completed.

If this column shows Failure, look in the Reason column for an explanation that can help you troubleshoot why the preposition task failed. After resolving the issue, you can schedule the preposition task to run again now, or wait until the scheduled start time and verify the status again later.

Starting and Stopping Preposition Tasks

You can start or stop a preposition task from the Device Manager GUI.

Configuring the SMB Accelerator

[Table 11-2](#) provides an overview of the steps that you must complete to configure the SMB accelerator.

Table 11-2 Checklist for Configuring SMB Accelerator

Task	Additional Information and Instructions
1. Prepare for file services.	Provides the tasks that you need to complete before enabling and configuring file services on your WAAS devices. For more information, see Preparing for File Services .

Table 11-2 Checklist for Configuring SMB Accelerator (continued)

Task	Additional Information and Instructions
2. Enable SMB acceleration.	Enables and configures the SMB accelerator. For more information, see Enabling and Disabling the Global Optimization Features of Chapter 12, “Configuring Application Acceleration.”
3. (Optional) Identify dynamic shares.	Identifies the dynamic shares on an exported file server. If your file server uses Access Based Enumeration (ABE) to give users different views of the share, you must configure the dynamic shares on the WAAS Central Manager. For more information, see Creating Dynamic Shares for the SMB Accelerator .
4. (Optional) Create a preposition directive.	Defines which files are proactively copied from an exported file server to the Edge WAE cache. For more information, see About Preposition Directives

About Preposition Directives

A preposition directive allows you to determine which files should be proactively copied from SMB file servers to the cache of selected Edge WAEs. Prepositioning enables you to take advantage of the idle time on the WAN to transfer frequently accessed files to selected WAEs, where users can benefit from cache-level performance even during first-time access of these files.



Note

Cisco SMB AO supports accelerating client connections to Microsoft DFS shares. However, Cisco SMB prepositioning does not support Microsoft DFS.

Prepositioning of SMB v3 encrypted traffic is not supported in this release.

Prepositioning is supported on automatically discovered file servers in the SMB accelerator.

When defining a preposition directive, select the Edge WAEs that you want to be prepositioned with content from the file server, and then specify the root directories on the file server to be prepositioned. Initially, the preposition directive is in the unscheduled state. You must create a schedule that determines when and how often the content is prepositioned.

In addition, you can specify time and size limits to prevent a preposition task from consuming too much bandwidth on the WAN or too much space on the Edge WAE cache. We strongly recommend that you use these limits to optimize network efficiency and prevent misuse of this feature.

When the activation time of a preposition directive arrives, a preposition task starts on the Edge WAE. Each preposition task can be monitored in the WAAS Central Manager GUI during and after processing. You can also terminate active preposition tasks, if required.

Prepositioning requires that the username and password needed to access the file server be specified. These items are specified directly in the Creating New Preposition Directive window, as described in [Creating a New Preposition Directive](#).



Note

When preposition updates are sent to the Central Manager, if any preposition file server credentials cannot be decrypted, all further preposition updates are not sent from the WAE to the Central Manager, and decryption failure error messages are logged in errorlog/cms_log.current. You must reconfigure the preposition credentials from the CLI.

Prepositioning includes the ability to configure multiple roots. See [Creating a New Preposition Directive](#).

When using prepositioning, both branch and data center WAEs are required (the same as for any other accelerated traffic). The branch WAE retrieves prepositioned files through an optimized connection. Verify that you have connectivity between the following network entities:

- Client to branch WAE
- Branch WAE to data center WAE
- Branch WAE to file server
- Data center WAE to file server

You will need to change any ACLs that might be blocking prepositioning traffic.



Note

Although preposition directives can be created and managed by using the CLI, we recommend that you use the Central Manager GUI because you can manage prepositioning for groups of WAEs from the Central Manager. If you mix GUI and CLI configuration, unpredictable results may occur because changes on one device can affect other devices.



Note

We recommend that you configure not more than 25 preposition directives per device.

If you want to enable DRE, you will need to select the **SMB Preposition DRE settings** checkbox, by navigating to the **Device > Configure > Acceleration > SMB Preposition Settings**. It is disabled by default.

Whenever DRE is enabled for the all prepositioning tasks, files are cached in Object Cache and DRE cache, particularly when the size of the prepositioned files is huge and this could affect the normal traffic. Else the files will be cached only in Object Cache.

The following topics describe how to create and manage a preposition directive:

- [Creating a New Preposition Directive, page 11-18](#)
- [Assigning Edge Devices to a Preposition Directive, page 11-22](#)
- [Creating a New Preposition Schedule, page 11-23](#)
- [Checking the Preposition Status, page 11-24](#)

Creating a New Preposition Directive

To create a preposition directive, follow these steps:

- Step 1** From the WAAS Central Manager menu, choose **Configure > SMB File Services > Preposition**. The Preposition Directives window appears. This window displays the following information about preposition directives that exist on the system:
- Preposition Directive—Name of the preposition directive.
 - Status—Whether the preposition directive is enabled or disabled.
 - File Server—Name of the exported file server.
 - Schedule Details—Schedule to determine how often content is prepositioned.

From the Preposition Directive window, you can perform the following tasks:

- Edit the configuration of an existing preposition directive by clicking the **Edit** icon next to the corresponding directive. You can then delete the preposition directive, or modify any of the settings.
- Assign the Device or Device Group (s) to the preposition operation by clicking the **Assign Device/DeviceGroup(s)** icon and select the appropriate one.
- Collect Preposition Status by clicking the Collect Preposition Status link.
- Add a new preposition directive, as described in the following steps.

Step 2 Click the **Create New Preposition** icon in the taskbar to create a new preposition directive. The Creating New Preposition Directive window appears. (Figure 11-3)

Figure 11-3 *Creating a New Preposition Directive Window*

Preposition Directive

Preposition Settings

Name: *

Enable Preposition

Total Size as % of Cache Volume: 5 (percentage) (1-100)

Max File Size: KB Min File Size: 20 KB

Duration: min

FileServer Settings

SMB v2 Signing

File Server: Nearest Device: Please make a choice

User Name: * Domain Name:

Password: * Confirm Password: *

Configure DNS server to resolve HostName to IP address if File Server is HostName.

Configure the Nearest Device which is closest to the file server to facilitate directory browsing.

Content Settings

Root Share and Directories: * Browse

Include Sub Directories

File Name: any Excludes

Schedule Settings

Frequency: Not Scheduled

Start time (HH:MM): 7:52

OK Cancel

354626

Step 3 Under **Preposition Settings**, enter a unique name for the directive. The name cannot contain characters other than letters, numbers, period, hyphen, and underscore; the double quote (") character is not allowed in the name.

Step 4 Click the **Enable Preposition** check box. This denotes status of preposition. This is unchecked by default. If you disable it, preposition is not possible.

Step 5 (Optional) Define the time and size limitations using the provided fields.

Table 11-3 describes the time and size limitation fields.

Table 11-3 Preposition Time and Size Limitations

Field	Description
Total Size as % of Cache Volume	<p>Percentage of the overall Edge WAE cache that prepositioned files can consume. For example, if you do not want this prepositioning directive to consume more than 30 percent of a WAE's cache, enter 30 in this field. The default value is 5 percent.</p> <p>The percentage of the cache defined for a preposition task defines the maximum size that can be prepositioned in a single iteration of the task regardless of how much is already in the cache.</p> <p>The total size of the files to be prepositioned will always be less than or equal to the total percentage of object cache size specified. Example, if the user had specified max-cache directive as 10% and total object-cache size is 100 GB, then the maximum size of the total files to be prepositioned for the task would be 10 GB(10% of 100 GB). If there are 100 files in the configured shares and first 50 files size up to 10 GB,then the rest of the files would not be prepositioned.</p> <p>When the cache is full, regardless of the reason, prepositioning operates like on-demand caching: an eviction process begins and the files with the oldest time-last-accessed values are removed from the cache.</p>
Max File Size	Maximum file size that can be exported. Files that are larger than this value are not exported to the WAE cache.
Min File Size	<p>Minimum file size that can be exported. Files that are smaller than this value are not exported to the WAE cache. It is inefficient to preposition files smaller than 20 KB because these files can be retrieved quickly over the WAN through normal WAAS.</p> <p>The default value is 20 KB.</p>
Duration	<p>Maximum amount of time it should take WAAS to export the file server. If it takes WAAS longer than this amount of time to export the file server, WAAS stops the exporting process before all files are copied to the Edge WAE cache.</p> <p>If the preposition task does not start at the scheduled start time, for example, because the Edge and the Core have no connection, the start retries are counted in the duration.</p> <p>If you do not specify a value for this field, WAAS takes as much time as needed to export this file server.</p>



Note If one of these limits is exceeded during a prepositioning task, the task is terminated and a message is sent to the Administrator log. Any remaining files are exported the next time the task is run. If a user requests one of the missing files before this happens, it is fetched over the WAN through WAAS software as usual.

- Step 6** Under **File Server Settings**, check the **SMBv2** checkbox to enable prepositioning of this traffic. This is disabled by default.
- Step 7** In the File Server field, enter the unique name of a file server to export. The name cannot contain characters other than letters, numbers, period, hyphen, and underscore; the double quote (") or forward slash (/) characters are not allowed in the name.

Step 8 From the Nearest Device drop-down list, choose the device location that will provide browsing services for the file server. Normally, this is the data center WAE. For the best browsing performance, specify a location that is close to the file server. The location is used only for browsing; each edge WAE will retrieve prepositioned files directly from the file server, not from this location. For more information on defining locations, see [Working with Device Locations](#).

Step 9 In the User name, Password, and Confirm Password fields, enter the username and password credentials for the file server. If the username is in a Windows domain, specify the domain name in the Domain name field.

The access credentials that you enter must allow read access to the prepositioned root directories and to their parent directories.

The following characters are not allowed to be used as username ; | & & || : \ / * ? < > + = , [] “ ` ! .

The following characters are not allowed to be used in server names ; | & & || , ~ : ! ` @ # \$ % ^ & ‘ { } () _ “

The following characters are not allowed to be used as domain names ; | & & || : \ / * ? < > “ ` !

Step 10 Under **Content Settings**, in the Root Share and Directories field, enter the directories on the file server that you want to export. Use any of the following methods to identify a directory:

- Manually enter one or more directory paths in the following format: *protocol://server/share* or *server\share*, for example, *cifs://win12srv/home* or *win12srv\home*. You can enter multiple lines for multiple directories, with each full directory path on its own line. You cannot specify the root directory (*/*) as a root share. Special characters like ; | & & || : * ? < > “ ` ! [] + = , are not allowed for top level shares. Additionally, when you create subdirectories inside the shares, the following special characters are not allowed: ; | & & || : * ? < > “ ` !



Note Do not use the special character “;” in files and directory names, else it will throw up errors. Additionally, we do not support extended Unicode characters in files and directories for release 6.2.1 and any such files or directories would be skipped and not prepositioned.

When you define multiple root shares, the preposition sequence that is performed for a single root configuration is repeated for each root serially.

- Click **Browse** to browse the directories on the file server. To navigate to a directory, click the File Folder icon to the left of the directory name. Check the check box next to the directory that you want to export and then click **Select Directory**. The browse window allows you to choose multiple directories.

The browse function operates best when you choose the location of the nearest SMB accelerator to the file server, from the Location drop-down list. If you do not choose a location, the browse request is sent to all the devices that have the SMB accelerator enabled, and the request may time out.

- Check the **Include Sub Directories** check box to include all the subdirectories under the specified root directory. If this option is not selected, only the files in the specified root directory are prepositioned and you cannot select subdirectories when you are browsing.
- Narrow the policy definition to a particular type of file by choosing a pattern operator from the File Name drop-down list and entering the text that describes the pattern in the adjacent text box, for example, enter **ends with .doc**. Do not use a space or the following special characters:
; | & & || : * ? < > \ / “ ` !

- Step 11** By default, a Now schedule begins (if the status is enabled) again each time you make a change to the preposition directive page. A new schedule also begins again as soon as an edge device that has been reloaded comes back online. Under **Schedule Settings**, select the frequency of preposition from the **Frequency** drop-down list.
- Not-Scheduled- By default this option will be displayed to user.
 - Immediate- Prepositioning occurs within a few minutes after click on ok button in schedule dialog.
 - Date - Prepositioning occurs at the defined time and date..
 - Daily-Prepositioning occurs daily at the defined time.
 - Weekly-Prepositioning occurs on the selected days of the week at the defined time.
 - Monthly Days-Prepositioning occurs on the selected days of the month at the defined time.
 - Monthly WeekDays - Prepositioning occurs on the selected month weekdays at the defined time
- Step 12** Specify the preposition start time from the **Start Time** drop-down list. The time is expressed in 24-hour format with 00:00 representing midnight. The time refers to the local time of the Edge WAE where the data is to be prepositioned. If there are multiple Edge WAEs in different time zones, the time refers to the local time of the Core WAE.
- Step 13** Click **OK**.
The directive is saved and is added to the preposition directive table.
-

Assigning Edge Devices to a Preposition Directive

After you create a preposition directive, you need to assign Edge WAEs or device groups to the directive. This task determines which Edge WAEs will store-preposition content in their cache.



Note Prepositioning includes the ability to configure multiple roots. See [Creating a New Preposition Directive](#).

To assign an Edge WAE or device group to a preposition directive, follow these steps:

- Step 1** From the WAAS Central Manager menu, choose **Configure > SMB File Services > Preposition**. The Preposition Directives window appears, which lists the preposition directives that exist on the system.
- Step 2** Select the appropriate Preposition Directive to assign it to the Device /Device Groups and click on **Assign Devices/ Device Groups** icon. The Assign Device/Device Groups Assignments window appears. The assignments window lets you filter your view of the items in the list. Filtering enables you to find items in the list that match the criteria that you set.
- Step 3** Choose the Edge WAEs or device groups to assign to this preposition directive and click **Assign**. The **Assigned Status** column changes to **Assigned** next to the selected Device/Device Groups. You can also un-assign a Device/Device Group by clicking on **Unassign**. The **Assigned Status** column changes to **Not Assigned** accordingly.
- Step 4** In case there is a delay in sending the preposition details to the device, the **Assigned Status** column displays NOTIFY UPDATES IN-PROGRESS for the Device/Device Group. Click on Refresh to see a change in status once the preposition changes have been made on the device.



Note If a device or device group is offline (identified by ) , then you cannot assign that device or group to this directive. The preposition directive, when assigned to a device group, is applied only to connected Edge devices in the assigned device group.

When assigning a SMB accelerator preposition directive to a device group, the directive is applied only to those devices enabled for SMB acceleration in the assigned device group.

Step 5 Click **OK**.



Note If the SMB accelerator is disabled on a WAE, the SMB accelerator preposition task will fail with error that SMB accelerator is not enabled on the WAE.

Creating a New Preposition Schedule

After you create a preposition directive and assign WAEs to the directive, we recommend that you create a schedule that determines when and how often prepositioning occurs.

For example, you may want to schedule prepositioning to occur at night to minimize the amount of traffic during business hours, or, you may want to schedule prepositioning to occur on a recurring basis if the exported data changes often. This will help ensure that the WAEs assigned to this directive have the latest file updates in their cache.

When a preposition task is scheduled to begin at the same time for multiple Edge WAEs that are located in different timezones, the task will begin on the Edge WAEs based on the Core WAE timezone. If the clocks of the Edge WAE and the Core WAE are not synchronized, the task will not start on time.

To create a preposition schedule, follow these steps:

Step 1 From the WAAS Central Manager menu, choose **Configure > SMB File Services > Preposition**.

The Preposition Directives window appears, which lists the preposition directives that exist on the system.

Step 2 Click the **Edit** icon next to the preposition directive for which you want to create a schedule.

Step 3 Click the **Schedule** tab at the top of the window.

The Creating New Preposition Schedule window appears. By default, no schedule is configured.

Step 4 Choose one of the following scheduling options:

- **Not Scheduled**—Prepositioning is not scheduled at this time.
- **Now**—Prepositioning occurs within a few minutes after you submit this schedule.
A Now schedule begins again each time you make a change to the preposition directive and click **Submit**. A Now schedule also begins again as soon as an Edge device that has been reloaded comes back online.
- **Daily**—Prepositioning occurs daily at the defined time.
- **Date**—Prepositioning occurs at the defined time and date.
- **Weekly**—Prepositioning occurs on the selected days of the week at the defined time.
- **Monthly Days**—Prepositioning occurs on the selected days of the month at the defined time.

- **Monthly Weekdays**—Prepositioning occurs on the defined day (as opposed to a defined date) and time during the month. For example, you can schedule prepositioning to occur on the second Tuesday of every month.

Step 5 Specify a start time for the prepositioning task.

The time is expressed in 24-hour format with 00:00 representing midnight. The time refers to the local time of the Edge WAE where the data is to be prepositioned. If there are multiple Edge WAEs in different time zones, the time refers to the local time of the Core WAE.



Note You cannot schedule a start time for the **Now** option.

Step 6 Click **Submit**.

The message Changes Submitted appears at the bottom of the window confirming that your schedule was saved.

Step 7 Verify that the preposition directive has completed successfully by checking the preposition status. For more information, see [Checking the Preposition Status](#).

Checking the Preposition Status

After you create one or more preposition directives, you can verify the status of all the preposition tasks to ensure that they are completed successfully. If a task does not complete successfully, then some of the prepositioned files may have not been copied to the Edge WAE cache.

To check the status of a prepositioning task, follow these steps:

Step 1 From the WAAS Central Manager menu, choose **Configure > SMB File Services > Preposition**.

The Preposition Directives window, which lists the preposition directives that exist on the system, appears.

Step 2 Select the SMB preposition directive that you want to check and click the **Collect Preposition Status** tab at the top of the window.

The Preposition Status window displays the following information:

- **WAE**—The name of each Edge WAE that received the prepositioned files in its cache.
- **Start Time**—The time the preposition task started.
- **Duration**—The amount of time it took the preposition task to be completed.
- **Amount Copied**—The amount of data copied to the WAE cache, in bytes.
- **Status**—Whether the preposition task is completed successfully.
- **Error Reason**—The reason a preposition task failed.

Ensure that the Status column shows Completed.

If this column shows Failure, look in the Reason column for an explanation that can help you troubleshoot why the preposition task failed. After resolving the issue, you can schedule the preposition task to run again now, or wait until the scheduled start time and verify the status again later.

Step 3 Click **OK**.

You can also export this data and save it to your local machine.

Creating Dynamic Shares for the SMB Accelerator

Many file servers use dynamic shares, which allow multiple users to access the same share but then be automatically mapped to a different directory based on the user's credentials. Dynamic shares are most commonly used on file servers to set up user home directories. For example, a directory named Home can be set up as a dynamic share on a file server so each user accessing that share is automatically redirected to their own personal directory.

If a file server contains a dynamic share or is using Access Based Enumeration (ABE), you must register that dynamic share with the WAAS Central Manager as described in this section.

Defining a dynamic share in the WAAS Central Manager allows each user to see a different view of the share and allows the operation of ABE if it is configured on the Windows Server.



Note

Dynamic share configuration on the WAAS Central Manager overrides any dynamic share configuration set up directly on the WAE device using the CLI.

Before adding a dynamic share, note the following limitations:

- Each dynamic share on a file server must be unique.
- You cannot add a dynamic share if that share has a preposition directive. You must remove the preposition policy before you can add the dynamic share.
- You can use the WAAS Central Manager GUI to define any directory as a dynamic share. However, if a directory is not set up as a dynamic share on the file server, all users will read or write the same content from the same directory and will not be redirected to different directories based on their credentials.

To add a dynamic share for SMB accelerator, follow these steps:

Step 1 From the WAAS Central Manager menu, choose **Devices > Configure > SMB File Services > Dynamic Shares**.

A list of dynamic shares appears. The Dynamic Shares window shows all the dynamic shares configured. From this window, you can perform the following tasks:

Edit the configuration of an existing dynamic share by clicking the Edit icon next to the share. You can delete the dynamic share, or modify any of the dynamic share settings.

Add a new dynamic share definition, as described in the next steps.

Step 2 Click the **Add Dynamic Share** icon in the taskbar to add a new dynamic share. The Creating a new Dynamic Share window appears.

Step 3 In the **File Server** field, enter the name or IP address of the file server with the dynamic share.

If you specify the file server name, the edge WAE resolves it to an IP address.

The registered file servers are displayed in a drop-down list.

Step 4 In the **Share** name field, specify the location of the dynamic share by doing one of the following tasks:

Enter the name of the dynamic share on the file server. The following characters cannot be used in the share name: \ / : * ? " < > |

Click Browse next to the Share Name field to navigate to the correct root directory.



Note The Browse button appears only if you have at least one WAE device with the SMB accelerator enabled and registered to the WAAS Central Manager.

Step 5 Click OK to submit the changes.

The specified directory now functions as a dynamic share on the Edge WAE cache.



Configuring Application Acceleration

This chapter describes how to configure the optimization policies, which determine the types of application traffic that is accelerated over your WAN on your WAAS system.



Note

Throughout this chapter, the term Cisco WAAS device is used to refer collectively to the Cisco Wide Area Application Services (Cisco WAAS) Central Managers and Cisco Wide Area Application Engines (WAEs) in your network. The term WAE refers to WAE and Cisco Wide Area Virtualization Engine (WAVE) appliances, Cisco Services Ready Engine (SRE) service modules (SMs) running WAAS, and Cisco Virtual WAAS (vWAAS) instances.

This chapter contains the following sections:

- [About Application Acceleration](#)
- [Enabling and Disabling the Global Optimization Features](#)
- [Configuring Individual Features and Application Accelerators](#)
- [Cisco Support for Microsoft Windows Update](#)
- [Creating a New Traffic Optimization Policy](#)
- [Managing Application Acceleration](#)

About Application Acceleration

The Cisco WAAS software comes with over 150 predefined optimization policies that determine the type of application traffic your WAAS system optimizes and accelerates. These predefined policies cover the most common type of application traffic on your network. For a list of the predefined policies, see [Appendix A, “Predefined Optimization Policy.”](#)

Each optimization policy contains the following elements:

- Application definition—Identifies general information about a specific application, such as the application name and whether the WAAS Central Manager collects statistics about this application.
- Class map—Contains a matching condition that identifies specific types of traffic. For example, the default HTTP class map matches all the traffic going to ports 80, 8080, 8000, 8001, and 3128. You can create up to 512 class maps and 1024 matching conditions.

- **Policy**—Combines the application definition and class map into a single policy. This policy also determines the optimization and acceleration features, if any, that a WAAS device applies to the defined traffic. You can create up to 512 policies. A policy can also contain a differentiated services code point (DSCP) marking value that is applied to the traffic and that overrides a DSCP value set at the application or global level.

You can use the WAAS Central Manager GUI to modify the predefined policies and to create additional policies for other applications. For more information on creating optimization policies, see [Creating a New Traffic Optimization Policy](#). For more information on viewing reports, restoring policies, monitoring applications, and other functions, see [Managing Application Acceleration](#).

**Note**

All application definitions configured in the WAAS Central Manager are globally applied to all the WAAS devices that register with the WAAS Central Manager, regardless of the device group membership configuration.

WAAS policies can apply two kinds of optimizations to matched traffic:

- Layer 4 optimizations that include TFO, DRE, and LZ compression. These features can be applied to all types of TCP traffic.
- Layer 7 optimizations that accelerate application-specific protocols. The application accelerators control these kinds of optimizations.

For a given optimization policy, the DRE feature can use different caching modes (beginning with WAAS Software Version 4.4.1):

- **Bidirectional**—The peer WAEs maintain identical caches for inbound and outbound traffic. This caching mode is best suited for scenarios where a significant portion of the traffic seen in one direction between the peers is also seen in the reverse direction. In WAAS software versions prior to 4.4.1, this mode is the only supported caching mode.
- **Unidirectional**—The peer WAEs maintain different caches for inbound and outbound traffic. This caching mode is best suited for scenarios where a significant portion of the traffic seen in one direction between the peers is not seen in the reverse direction.
- **Adaptive**—The peer WAEs negotiate either bidirectional or unidirectional caching based on the characteristics of the traffic seen between the peers.

The predefined optimization policies are configured to use the optimal DRE caching mode, depending on the typical application traffic, although you can change the mode if you want.

Enabling and Disabling the Global Optimization Features

The global optimization features determine if traffic flow optimization (TFO), data redundancy elimination (DRE), and persistent compression are enabled on a device or device group. By default, all of these features are enabled. If you choose to disable one of these features, the device will be unable to apply the full WAAS optimization techniques to the traffic that it intercepts.

In addition, the global optimization features include each of the following application accelerators: EPM, HTTP, ICA, MAPI, NFS, SMB, and SSL and SSL Interposer. By default, all of the application accelerators are enabled except SMB, SSL Interposer and Encrypted MAPI.

**Note**

The application accelerators require specific types of licenses to operate: a Transport license for TFO, DRE, and LZ optimization, and an Enterprise license for all other application accelerators. For more information on installing and managing licenses, see [Managing Software Licenses](#) in Chapter 10, “Configuring Other System Settings.”

This section contains the following topics:

- [Procedure for Enabling and Disabling the Global Optimization Features](#)

Procedure for Enabling and Disabling the Global Optimization Features

**Note**

You must enable the accelerator on both of the peer WAEs at either end of a WAN link for all application accelerators to operate.

However, in case of SMART-SSL acceleration, you do not need a peer WAE to exist or for both WAEs to have the SSL Interposer accelerator enabled.

To enable or disable a global optimization feature, follow these steps:

Step 1 From the WAAS Central Manager menu, choose **Devices** > *device-name* (or **Device Groups** > *device-group-name*).

Step 2 Choose **Configure** > **Acceleration** > **Enabled Features**.

The Enabled Features window appears.

346121



Note On WAAS Express devices, only a subset of the standard features are available. On ISR-WAAS devices, the SMB application accelerator is enabled by default. In the Enabled Features window for a device group, two SMB Accelerator options are shown, one for ISR-WAAS devices and one for all other kinds of WAEs.

For WAAS Express, the following Express versions of application accelerators are supported:

- HTTP accelerator express (See [Configuring HTTP Acceleration](#))
- SSL accelerator express (See [Configuring SSL Acceleration](#))



Note For a Cisco WAAS device running WAAS Version 6.x and a Cisco WAAS Express peer device running Cisco IOS Release 15.6(3)M, 15.6(2)T1 or later, *TLS1 is supported, but SSL3 is removed*. Before upgrading WAAS Express to one of these IOS releases, configure TLS1 in the WAAS Express Device Group:

1. Navigate to **Device Groups** > *DeviceGroupName* > **Configure** > **Enabled Features**.
2. Select the SSL Accelerator Express **Peering Service**.
3. At the **SSL Version:** dropdown list, select **TLS1**.
4. Click **Submit**.
5. Upgrade the WAAS Express.

For information on upgrading and interoperability, see the [Release Note for Cisco Wide Area Application Services](#).

Not all of the properties in the standard WAAS device are available in the WAAS Express version of the application accelerators, including SMART-SSL acceleration.



Note If you try to enable DRE on a WAAS Express device on which it is not supported, a message stating that it is not supported is displayed.

The Restore Predefined Settings icon for WAAS Express applies the predefined settings for HTTP/HTTPS, and SSL cipher list and peering service.

Step 3 Check the check boxes adjacent to the optimization features that you want to enable, and uncheck the check boxes adjacent to the features that you want to disable. For a description of each of the optimization features, see [Key Services of Cisco WAAS](#) in Chapter 1, “Introduction to Cisco WAAS.” Some features have additional settings that you can configure by clicking the link next to the setting name. Hover your cursor over the small target icon next to the link to see a dialog box that shows the current settings.

- If you check the **Data Redundancy Elimination** check box, you can click the DRE Settings link as a shortcut to the DRE Settings Configuration window. For more information, see [Configuring DRE Settings](#).
- If you check the **HTTP Accelerator** check box, you can click the **HTTP Settings** link as a shortcut to the HTTP/HTTPS Settings window. For more information, see [Configuring HTTP Acceleration](#).
- If you check the **ICA Accelerator** check box, you can click the **ICA Settings** link as a shortcut to the ICA Acceleration Configuration window. For more information, see [Configuring ICA Acceleration](#).
- If you check the **MAPI Accelerator** check box, you can click the **MAPI Settings** link as a shortcut to the MAPI Settings window. For more information, see [Configuring MAPI Acceleration](#).



Note When you check the **MAPI Accelerator** check box, Encrypted MAPI Traffic Optimization is enabled by default.

- If you check the **Encrypted MAPI Traffic Optimization** check box, you can click the **Mandatory Encryption Configuration** link as a shortcut to the Encrypted Services Configuration window. For more information, see [Configuring Encrypted MAPI Acceleration](#).



Note You must enable MAPI acceleration first for Encrypted MAPI acceleration to be enabled.

- If you check the **SMB Accelerator** check box, you can click the **SMB Settings** link as a shortcut to the SMB Acceleration Configuration window. For more information, see [Configuring SMB Acceleration](#).
- If you check the **SSL Accelerator** check box, you must configure additional settings to enable SSL acceleration. For more information, see [Configuring SSL Acceleration](#). With release 6.2.1, you can accelerate o365 traffic. For more information, see [office365 optimization using Azure vWAAS](#).
- If you check the **SSL Interposer (SSL Accelerator V2)** check box, you must configure additional settings to enable SMART-SSL acceleration. By default, the SSL Interposer is disabled. For more information, see [Configuring SMART-SSL Accelerator](#).



Note Both SSL accelerator and SMART-SSL can co-exist on a device.

Step 4 To enable the object cache, in the **Object Cache Settings** section, check the **Object Cache** check box.

WAAS performs object caching to increase client application performance for SMB file access. Object caching also minimizes bandwidth and latency over the WAN, by avoiding the repeated transfer of data over the WAN.



Note Object Cache is not supported on vWAAS-200 and vWAAS-150 platforms.

To enable an individual application accelerator object cache, use the following guideline:

- Controls to enable and disable an individual object cache are displayed in that application accelerator's **Advanced Settings** screen.



Note

To ensure that the object cache and individual application accelerator object cache work successfully, note these guidelines:

- Each application accelerator object cache can be enabled or disabled independent of whether or not the global object cache is enabled or disabled.
 - Enabling the object cache does not automatically enable individual application accelerator object caches.
 - You can enable or disable an individual application accelerator object cache whether or not the associated application accelerator is enabled or disabled.
 - Verify that disk assignments have been made to object cache before you enable object cache.
 - The object cache has a limit of 15 GB. A request of a size larger than this limit will not cache the complete file. For example, for a file size of 25 GB, only 15 GB of this file would be cached.
-



Note

To ensure that the object cache and SMB application accelerator work successfully, enable the object cache before you enable the SMB application accelerator.

Step 5 In the **Advanced Settings** area, uncheck the **Blacklist Operation** check box if you want to disable it. This feature allows a WAE to better handle situations in which TCP setup packets that have options are blocked or not returned to the WAE device. This behavior can result from network devices (such as firewalls) that block TCP setup packets that have options, and from asymmetric routes. The WAE can keep track of origin servers (such as those behind firewalls) that cannot receive optioned TCP packets, and learns not to send out TCP packets with options to these blacklisted servers. WAAS is still able to accelerate traffic between branch and data center WAEs in situations where optioned TCP packets are dropped. We recommend that you leave this feature enabled.

Step 6 If you want to change the default Blacklist Server Address Hold Time of 60 minutes, enter the new time in minutes in the Blacklist Server Address Hold Time field. The valid range is 1 minute to 10080 minutes (1 week).

When a server IP address is added to the blacklist, it remains there for the configured hold time. After that time, subsequent connection attempts will again include TCP options so that the WAE can redetermine if the server can receive them. It is useful to retry sending TCP options periodically because network packet loss may cause a server to be erroneously blacklisted.

You can shorten or lengthen the blacklist time by changing the Blacklist Server Address Hold Time field.

Step 7 Click **Submit**.

The changes are saved to the device or device group.

To configure TFO optimization, DRE, and persistent compression from the CLI, use the **tfo optimize** global configuration command.

To configure EPM acceleration from the CLI, use the **accelerator epm** global configuration command.

To configure HTTP acceleration from the CLI, use the **accelerator http** global configuration command.

To configure ICA acceleration from the CLI, use the **accelerator ica** global configuration command.

To configure MAPI acceleration from the CLI, use the **accelerator mapi** global configuration command.

To configure NFS acceleration from the CLI, use the **accelerator nfs** global configuration command.

To configure SMB acceleration from the CLI, use the **accelerator smb** global configuration command.

To configure SSL acceleration from the CLI, use the **accelerator ssl** global configuration command.

To configure global object cache from the CLI, use the **object-cache enable** global configuration command.

When object cache is enabled, you are prompted to confirm the repurposing of SMB resources if the disk has not already been partitioned for object cache.

If this is the first time disk resources are being assigned to object cache, the **object-cache enable** command will prompt you to reboot the device, since the disk partitioning only takes effect on the next reboot. The configuration is then saved, and the object cache does not have to be re-enabled on the next reboot.

**Note**

To ensure success of the **object-cache enable** command, verify the following two conditions:

- Disk assignments have been made to object cache *before* you use this command.
 - Use this command *before* you use the **accelerator smb** global configuration command.
-

To enable a specified application accelerator object cache, use the **accelerator ao-name object-cache enable** global configuration command.

**Note**

To ensure that each application accelerator object cache and the global object cache function successfully, note these guidelines:

- Each application accelerator object cache can be enabled or disabled independent of whether or not the global object cache is enabled or disabled.
 - You must disable all individual application accelerator object caches *before* you use the **no object-cache enable** global configuration command to disable the global object cache.
 - The **object-cache enable** global configuration command does not automatically enable individual application accelerator object caches.
 - You can enable or disable an individual application accelerator object cache whether or not the associated application accelerator is enabled or disabled.
-

To configure the Blacklist Operation feature from the CLI, use the **auto-discovery** global configuration command.

To display status and statistics on the application accelerators from the CLI, use the **show accelerator** and **show statistics accelerator EXEC** commands.

To display statistics on the SMB print accelerator, use the **show statistics accelerator smb EXEC** command.

Configuring Individual Features and Application Accelerators

This section contains the following topics:

- [Configuring DRE Settings](#)
- [Configuring HTTP Acceleration](#)
- [Configuring MAPI Acceleration](#)
- [Configuring Encrypted MAPI Acceleration](#)
- [Configuring SMB Acceleration](#)
- [Configuring ICA Acceleration](#)
- [Configuring SSL Acceleration](#)
- [Configuring SMART-SSL Accelerator](#)

Configuring DRE Settings

To enable DRE settings, check the **Data Redundancy Elimination** check box in the Enabled Features window.

To configure the DRE auto bypass and load monitor settings, follow these steps:

-
- Step 1** From the WAAS Central Manager menu, choose **Devices > device-name** (or **Device Groups > device-group-name**).
- Step 2** Choose **Configure > Acceleration > DRE Settings**.
The DRE Settings window appears.
- Step 3** Check the **Enable DRE auto bypass** check box to generate an alarm and automatically DRE bypass application traffic.



Note If you do not enable DRE auto bypass, the Device Status alarm displays yellow and the traffic gets bypassed without forwarding to the Service Node (SN). We recommend that you do not disable DRE through the configuration. Instead, configure individual policies to bypass DRE functionality.

- Step 4** Check the **Enable DRE Load Monitor** check box to enable load report.
- The **disk latency maximum** can be set from 1-1000; the default value is 5.
 - The **DRE load threshold** can be set from 50-99; the default value is 95.
- Step 5** Click **Submit**.

The changes are saved to the device or device group.

To enable DRE auto bypass from the CLI, use the **dre auto-bypass enable** global configuration command.

To enable DRE load monitor from the CLI, use the **dre load-monitor report** global configuration command.

Configuring HTTP Acceleration

The HTTP application accelerator accelerates HTTP traffic. To optimize HTTPS, you must enable both SSL and HTTP and also have protocol chaining enabled.

The default Web optimization policy is defined to send traffic to the HTTP accelerator. The Web optimization policy uses the HTTP class map, which matches traffic on ports 80, 8080, 8000, 8001, and 3128. If you expect HTTP traffic on other ports, add the other ports to the HTTP class map.

To enable the HTTP accelerator, check the **HTTP Accelerator** check box in the Enabled Features window .

To configure the HTTP acceleration settings, follow these steps:

-
- Step 1** From the WAAS Central Manager menu, choose **Devices** > *device-name* (or **Device Groups** > *device-group-name*).
- Step 2** Choose **Configure** > **Acceleration** > **HTTP/HTTPS Settings**.
The HTTP Acceleration Settings window appears ([Figure 12-1](#)).



Note For WAAS Express, the HTTP acceleration settings are the same, but the fields are laid out differently in the HTTP/HTTPS Settings window.

Figure 12-1 HTTP Acceleration Settings Window

The screenshot displays the 'HTTP/HTTPS Settings' window in the Cisco Wide Area Application Services (WAAS) configuration interface. The page is titled 'Cisco Wide Area Application Services' and shows the configuration for device 'WAE-231-03'. The 'Metadata Cache Settings' section is expanded, showing the following options:

- Enable HTTP Metadata Cache
- Enable HTTPS Metadata Cache
- Maximum age of Cache entry: (seconds) (5-2592000)
- Minimum age of Cache entry: (seconds) (5-86400)
- Enable local HTTP 301 Redirect messages
- Enable local HTTP 401 Authentication-required messages
- Enable local HTTP 304 Not-Modified messages

The 'File Extension Filters' field is currently empty. Below the Metadata Cache Settings, the 'Sharepoint Settings' section has Enable Pre-fetch Optimization. The 'Server Compression Settings' section has Suppress server compression for HTTP and HTTPS. The 'DRE Hints Settings' section has Enable DRE Hints for HTTP and HTTPS. At the bottom of the settings area, there are 'Submit' and 'Reset' buttons. The bottom right corner of the interface shows an 'Alarms' section with 0 red, 5 yellow, and 0 green indicators.

- Step 3** Check the **Enable HTTP metadatacache caching** check box to enable the WAE to cache HTTP header (metadata) information. The default setting is checked.
- This check box must be checked to enable any of the other settings in the Metadata Cache Settings area. If this box is not checked, no header caching is done.
- For details on HTTP metadata caching, see [About HTTP Metadata Caching](#).
- Step 4** Check the **Enable HTTPS metadatacache caching** check box to enable the WAE to cache HTTPS header (metadata) information (HTTP as payload in SSL traffic). The default setting is checked.
- For details on HTTP metadata caching, see [About HTTP Metadata Caching](#).
- Step 5** In the Maximum age of a Cache entry field, enter the maximum number of seconds to retain HTTP header information in the cache. The default is 86400 seconds (24 hours). Valid time periods range from 5–2592000 seconds (30 days).
- Step 6** In the Minimum age of a Cache entry field, enter the minimum number of seconds for which to retain HTTP header information in the cache. The default is 60 seconds. Valid time periods range from 5 to 86400 seconds (24 hours).
- Step 7** Check the **Enable local HTTP 301 redirect messages** check box to enable the WAE to cache and locally serve HTTP 301 messages. The default setting is checked.
- Step 8** Check the **Enable local HTTP 401 Authentication-required messages** check box to enable the WAE to cache and locally serve HTTP 401 messages. The default setting is checked.
- Step 9** Check the **Enable local HTTP 304 Not-Modified messages** check box to enable the WAE to cache HTTP 200 and 304 messages and locally serve HTTP 304 messages. The default setting is checked.

Step 10 To configure specific file extensions to which metadata caching is to be applied, enter the file extensions in the File extension filters field at the far right. Separate multiple extensions with a comma, for example, jpeg, gif, png, and do not include the dot at the beginning of the file extension.

By default, no file extension filters are defined and therefore, metadata caching applies to all file types.

Step 11 Check the **Enable Pre-fetch Optimization** check box to allow the edge WAAS device to prefetch data. This setting is not enabled by default.

This optimization benefits Web browser-based Microsoft Office applications when they access Microsoft Office documents (MS Word and Excel only) hosted on a Microsoft SharePoint Server 2010. For viewing Word documents, the client must have Microsoft Silverlight installed.

By checking this check box, you are telling the edge WAAS device to prefetch the subsequent pages of the documents from the SharePoint server before the client actually requests them, and serve them from the cache when the request from the client arrives. You can now seamlessly scroll through the document without having to wait for the content to load.



Note SharePoint prefetch optimization works with view in browser mode only.

Step 12 Check the **Suppress server compression for HTTP and HTTPS** check box to configure the WAE to suppress server compression between the client and the server. The default setting is checked.

By checking this check box, you are telling the WAE to remove the Accept-Encoding value from HTTP and HTTPS request headers, preventing the web server from compressing HTTP and HTTPS data that it sends to the client. This allows the WAE to apply its own compression to the HTTP and HTTPS data, typically resulting in much better compression than the web server for most files. For some file types that rarely change, such as .css and .js files, this setting is ignored and web server compression is allowed.

Step 13 Check the **Enable DRE Hints for HTTP and HTTPS** check box to send DRE hints to the DRE module for improved DRE performance. The DRE hint feature is enabled by default.

Step 14 Click **Submit**.

The changes are saved to the device or device group.

To configure HTTP acceleration from the CLI, use the **accelerator http** global configuration command.

To show the contents of the metadata cache, use the **show cache http-metadataacache EXEC** command.

To clear the metadata cache, use the **clear cache http-metadataacache EXEC** command.

To enable or disable specific HTTP accelerator features for specific clients or IP subnets, use the HTTP accelerator subnet feature. For more details, see [Using an HTTP Accelerator Subnet](#).

About HTTP Metadata Caching

The metadata caching feature allows the HTTP accelerator in the branch WAE to cache particular server responses and respond locally to clients. The following server response messages are cached:

- **HTTP 200 OK** (Applies to If-None-Match and If-Modified-Since requests)
- **HTTP 301 redirect**
- **HTTP 304 not modified** (Applies to If-None-Match and If-Modified-Since requests)
- **HTTP 401 authentication required**

Metadata caching is not applied in the following cases:

- Requests and responses that are not compliant with RFC standards
- URLs containing over 255 characters
- 301 and 401 responses with cookie headers
- Use of HEAD method
- Pipelined transactions

**Note**

The metadata caching feature is introduced in WAAS Version 4.2.1, but Version 4.2.1 is needed only on the branch WAE. This feature can interoperate with an HTTP accelerator on a data center WAE that has a lower version.

Using an HTTP Accelerator Subnet

The HTTP accelerator subnet feature allows you to selectively enable or disable specific HTTP optimization features for specific IP subnets by using ACLs. This feature can be applied to the following HTTP optimizations: HTTP metadata caching, HTTPS metadata caching, DRE hints, and suppress server compression.

To define IP subnets, use the **ip access-list** global configuration command. Refer to this command in the [Cisco Wide Area Application Services Command Reference](#) for more information on configuring subnets. You can use both standard and extended ACLs.

To configure a subnet for an HTTP accelerator feature, follow these steps:

Step 1 Enable global configuration for all the HTTP accelerator features that you want to use.

Step 2 Create an IP access list to use for a subnet of traffic:

```
WAE(config)# ip access-list extended md_acl
WAE(config-ext-nacl)# permit ip 1.1.1.0 0.0.0.255 any
WAE(config-ext-nacl)# permit ip 2.2.2.0 0.0.0.255 3.3.3.0 0.0.0.255
WAE(config-ext-nacl)# exit
```

Step 3 Associate the ACL with a specific HTTP accelerator feature. Refer to the **accelerator http** global configuration command in [Cisco Wide Area Application Services Command Reference](#) for information on associating an ACL with an HTTP accelerator feature:

```
WAE(config)# accelerator http metadatacache access-list md_acl
```

In this example, the HTTP metadata cache feature applies to all the connections that match the conditions specified in the extended access-list md_acl.

In the following example, the HTTP suppress-server-encoding feature applies to all the connections that match the conditions specified in the standard access-list 10:

```
WAE(config)# ip access-list standard 10
WAE(config-std-nacl)# permit 1.1.1.0 0.0.0.255
WAE(config-std-nacl)# exit
WAE(config)# accelerator http suppress-server-encoding accesslist 10
```

For the features (DRE hints and HTTPS metadata cache in this example) that do not have an ACL associated with them, global configuration is used and the features are applicable to all the connections.

Configuring MAPI Acceleration

The MAPI application accelerator accelerates Microsoft Outlook Exchange traffic that uses the Messaging Application Programming Interface (MAPI) protocol.

- For WAAS Version 5.3.x and later, Microsoft Outlook 2000–2013 clients are supported.
- For WAAS Version 5.2.x and earlier, Microsoft Outlook 2000–2010 clients are supported.

Clients can be configured with Outlook in cached or noncached mode; both modes are accelerated.

Secure connections that use message authentication (signing) are not accelerated, and MAPI over HTTP is not accelerated.

**Note**

Microsoft Outlook 2007 and 2010 have encryption enabled by default. You must disable encryption to benefit from the MAPI application accelerator.

The EPM application accelerator must be enabled for the MAPI application accelerator to operate. EPM is enabled by default. Additionally, the system must define an optimization policy of type EPM, specify the MAPI UUID, and have an Accelerate setting of MAPI. This policy, MAPI for the Email-and-Messaging application, is defined by default.

EPM traffic, such as MAPI, does not normally use a predefined port. If your Outlook administrator has configured Outlook in a nonstandard way to use a static port, you must create a new basic optimization policy that accelerates MAPI traffic with a class map that matches the static port that was configured for Outlook.

**Note**

If the WAE becomes overloaded with connections, the MAPI application accelerator continues to accelerate MAPI connections by using internally reserved connection resources. If the reserved resources are also exceeded, new MAPI connections are passed through until connection resources become available.

To enable the MAPI accelerator, check the **MAPI Accelerator** check box in the Enabled Features section.

**Note**

When you enable MAPI acceleration, Encrypted MAPI acceleration is enabled by default.

To configure MAPI acceleration settings, follow these steps:

Step 1 From the WAAS Central Manager menu, choose **Devices > device-name** (or **Device Groups > device-group-name**).

Step 2 Choose **Configure > Acceleration > MAPI Settings**.

The MAPI Acceleration Settings window appears ([Figure 12-2](#)).

Figure 12-2 MAPI Acceleration Settings Window

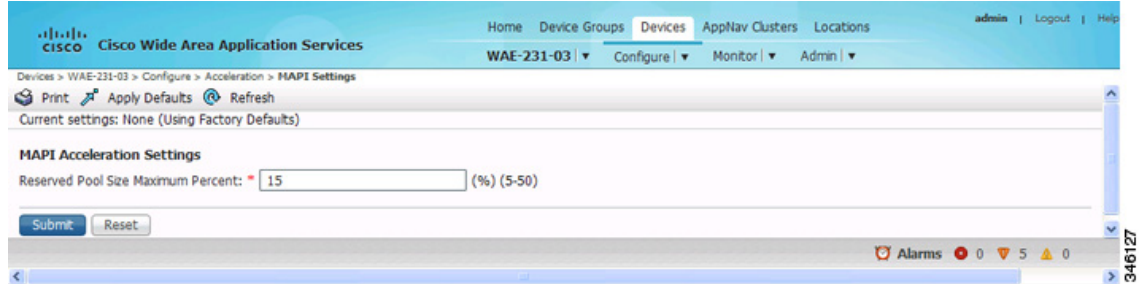

- Step 3** In the Reserved Pool Size Maximum Percent field, enter the maximum percent of connections in order to restrict the maximum number of connections reserved for MAPI optimization during TFO overload. It is specified as a percent of the TFO connection limit of the platform. Valid percent ranges from 5 to 50 percent. The default is 15 percent, which reserves approximately 0.5 connection for each client-server Association Group (AG) optimized by the MAPI accelerator.

The client maintains at least one AG per server it connects to with an average of about three connections per AG. For deployments that see a greater average number of connections per AG, or where TFO overload is a frequent occurrence, a higher value for reserved pool size maximum percent is recommended.

Reserved connections remain unused when the device is not under TFO overload. Reserved connections are released when the AG is terminated.

- Step 4** Click **Submit**.

The changes are saved to the device or device group.

Configuring Encrypted MAPI Acceleration

The Encrypted MAPI acceleration feature provides WAN optimization for secure MAPI application protocols using Microsoft Kerberos security protocol and Microsoft Windows Active Directory identity for authentication of clients or servers or both in the domain.

This section contains the following topics:

- [MAPI Operating Considerations](#)
- [Terms Used with Microsoft Active Directory](#)
- [Configuring Encrypted MAPI Settings](#)
- [Configuring a Machine Account Identity](#)
- [Creating and Configuring a User Account](#)
- [Configuring Microsoft Active Directory](#)
- [Managing Domain Identities and Encrypted MAPI State](#)

MAPI Operating Considerations



Note

You must enable MAPI acceleration first for Encrypted MAPI acceleration to be enabled. Encrypted MAPI acceleration is enabled by default.

Terms Used with Microsoft Active Directory

The following terms are used with Microsoft Active Directory and Cisco Encrypted MAPI acceleration:

- **Microsoft Active Directory**—A set of directory-based and identity-based services developed by Microsoft for Windows domain networks. The Microsoft Active Directory Domain Services (DS) domain controller stores information about domain users and devices
- **User Identity**—An Active Directory user account. The Microsoft Active Directory employs the user identity to authenticate the user, and to grant appropriate access to domain resources.
- **Machine Account Identity**—A computer (machine) account used to authenticate the user's computer access to Microsoft Active Directory Domain Services. Each Windows Active Directory computer has a unique machine (computer) account.

For more information on Microsoft Active Directory, see the *Microsoft Developer Network Active Directory* pages.

Workflow for Configuring Encrypted MAPI

To configure Encrypted MAPI traffic acceleration, complete the tasks listed in [Table 12-1](#). These tasks must be performed on both data center and branch WAEs unless specified as Not Required or Optional.

Table 12-1 Tasks for Configuring Encrypted MAPI

Task	Additional Information and Instructions
1. Configure DNS Settings.	To configure DNS settings, see Configuring the DNS Server in Chapter 6, “Configuring Network Settings.”
2. Configure NTP Settings.	To synchronize the time with Active Directory, see Configuring NTP Settings in Chapter 10, “Configuring Other System Settings.”
3. Verify WAE devices are registered and online with the WAAS Central Manager.	To verify WAE devices are registered and online with the WAAS Central Manager, see Devices Window in Chapter 15, “Monitoring Your WAAS System.”
4. Configure SSL Peering Service.	To configure SSL Peering Service, see Configuring SSL Peering Service .
5. Verify WAN Secure mode is enabled.	To verify WAN Secure mode is enabled, use the show accelerator wansecure EXEC command.

Table 12-1 Tasks for Configuring Encrypted MAPI (continued)

Task	Additional Information and Instructions
<p>6. (Optional) Configure windows domain settings and perform domain join. The domain join function automatically creates the machine account in Active Directory.</p> <p> Note It is sufficient to create any one identity account, either machine or user. Domain-join is required only for machine account used as an identity account.</p>	<p>To configure Windows Domain Server Authentication settings, see Configuring Windows Domain Server Authentication Settings in Chapter 7, “Configuring Administrative Login Authentication, Authorization, and Accounting.”</p> <p>Note that performing a domain join of the WAE is not required on branch WAE devices.</p>
7. Configure domain identities (for machine account and optional user accounts).	<p>To configure a machine account identity, see Configuring a Machine Account Identity.</p> <p>(Optional) To create a user account and configure a user account identity, see Creating and Configuring a User Account.</p> <p>Note that configuring domain identities is not required on branch WAE devices.</p>
8. Enable Windows Domain Encrypted Service.	To enable the Windows Domain Encrypted Service, navigate to the Configure > Security > Windows Domain > Encrypted Services page and check the Enable Encrypted Service check box.
9. Enable Encrypted MAPI Traffic Optimization.	To enable Encrypted MAPI Traffic, see Enabling and Disabling the Global Optimization Features .

Configuring Encrypted MAPI Settings

To configure encrypted MAPI settings, follow these steps:

Step 1 Configure DNS settings.

The WAAS DNS server must be a part of the DNS system of Windows Active Directory domains to resolve DNS queries for traffic encryption.

For more information about configuring DNS settings, see [Configuring the DNS Server](#) in Chapter 6, “Configuring Network Settings.”

Step 2 Configure NTP settings to synchronize the time with the Active Directory.

The WAAS device has to be in synchronization with the Active Directory for Encrypted MAPI acceleration. The WAAS NTP server must share time synchronization with the Active Directory Domain Controllers’ domains for which traffic encryption is required. Out-of-sync time will cause Encrypted MAPI acceleration to fail.

For more information about synchronizing time with the Active Directory, see [Configuring NTP Settings](#) in Chapter 10, “Configuring Other System Settings.”

Step 3 Verify if WAE devices are registered and are online with the WAAS Central Manager.

For more information about verifying that WAE devices are registered and are online with the WAAS Central Manager, see [Devices Window](#) in Chapter 15, “Monitoring Your WAAS Network.”

Step 4 Configure the SSL Peering Service.



Note The SSL accelerator must be enabled and in running state.

For more information about configuring the SSL Peering Service, see [Configuring SSL Peering Service](#).

Step 5 Verify if WAN Secure mode is enabled.

The default mode is Auto. You can verify the state of WAN Secure mode using the following EXEC command:

show accelerator wansecure

If necessary, you can change the state of WAN Secure using the following global configuration command:

accelerator mapi wansecure-mode {always | auto | none}

Step 6 (Optional on data center WAEs if only user accounts are used for domain identity configuration in Step 7.) Configure Windows domain settings and perform a domain join. (A domain join automatically creates the machine account in Active Directory.) It is sufficient to create any one identity account, either machine or user. Domain-join is required only for machine account used as an identity account.



Note Performing a domain join of the WAE is not required on branch WAE devices.

To configure Windows Domain Server Authentication settings, see [Configuring Windows Domain Server Authentication Settings](#) in Chapter 7, “Configuring Administrative Login Authentication, Authorization, and Accounting.”



Note Kerberos and Windows NT LAN Manager (NTLM) authentication are used for Encrypted MAPI acceleration. For WAAS 5.3.1, encrypted NTLM traffic is supported for EAPI, and the WAE device optimizes NTLM traffic for domains configured with NTLM authentication.

Step 7 Configure domain identities. (Not required for branch WAEs.)

As mentioned in Step 6, you must have at least one account, either user or machine, that is configured with a domain identity. Each device can support up to five domain identities, one machine account identity and four user account identities. This allows a WAAS device to accelerate up to five domain trees. You must configure a domain identity for each domain with an exchange server that has clients to be accelerated.

a. Configure the machine account identity.

A machine account for the core device is automatically created during the join process in the Windows Domain Server authentication procedure in Step 6. If you are using a machine account, a machine account identity must be configured for this account.

Each device supports only one machine account identity.

To configure a machine account identity, see [Configuring a Machine Account Identity](#).

b. Create and configure optional user accounts.

You can utilize up to four optional user accounts for additional security. Multiple user accounts provide greater security than having all of the core devices using a single user account. You must configure a user account identity for each user account, whether you are utilizing an existing user account or creating a new one.

To create a user account and configure a user account identity, see [Creating and Configuring a User Account](#).

- Step 8** Enable Windows Domain Encrypted Service. (This is enabled by default.)
- From the WAAS Central Manager menu, choose **Devices** > *device-name* (or **Device Groups** > *device-group-name*).
 - From the menu, choose **Configure** > **Security** > **Windows Domain** > **Encrypted Services**.
The Encrypted Services window appears.
 - Check the **Enable Encrypted Service** check box.
 - Click **Submit** to save your changes.

- Step 9** Enable Encrypted MAPI Traffic Optimization.

In the Enabled Features window, check the **Encrypted MAPI Traffic Optimization** check box (the **MAPI Accelerator** check box must also be checked), and click **Submit**. (Encrypted MAPI traffic optimization is enabled by default.)

For more information on the Enabled Features window, see [Enabling and Disabling the Global Optimization Features](#).

Configuring a Machine Account Identity



Note For definitions of machine account identity and other Microsoft Active Directory terms, see [Terms Used with Microsoft Active Directory](#).

To configure an identity for a machine account, follow these steps:

- Step 1** From the WAAS Central Manager menu, choose **Devices** > *device-name* (or **Device Groups** > *device-group-name*).
- Step 2** From the menu, choose **Configure** > **Security** > **Windows Domain** > **Encrypted Services**.
The Encrypted Services window appears.
- Step 3** Click the **Add Domain Identity** button.
The Domain Identity dialog box appears ([Figure 12-3](#)).



Note Every WAAS device that has to be accelerated must have a domain identity.

Figure 12-3 Add Domain Identity—Machine Account

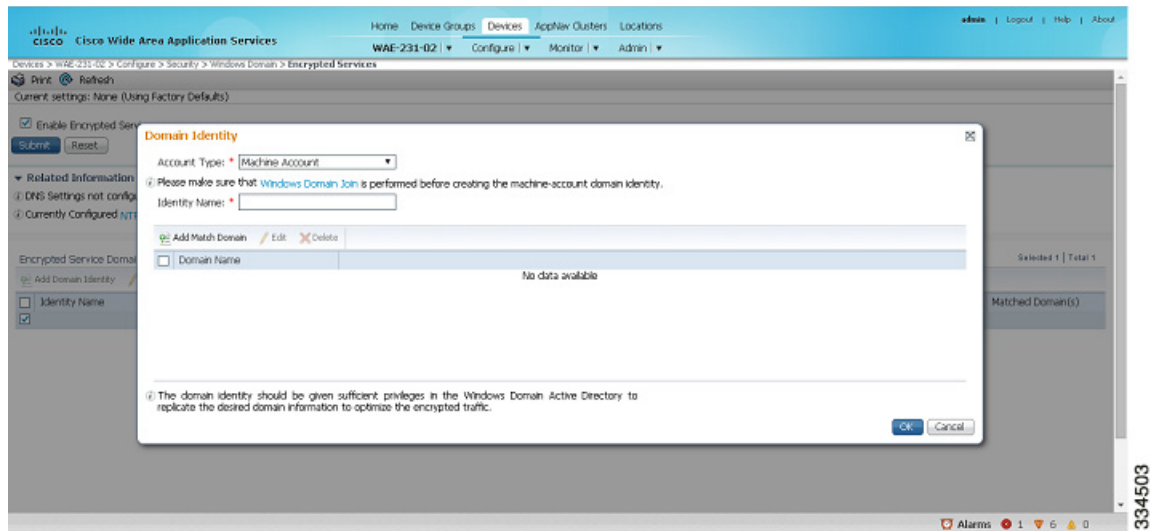

- a. In the Domain Identity dialog box that is displayed, choose **Machine Account** from the Account Type drop-down list.



Note Windows domain join must be completed before creating the machine account domain identity. For more information, see [Configuring Windows Domain Server Settings on a WAAS Device](#) in Chapter 7, “Configuring Administrative Login Authentication, Authorization, and Accounting.”

- b. Enter the identity name in the Identity Name field. Only alphanumeric characters are allowed. Space, ?, and | are not allowed. The length is not to exceed 32 characters.



Note The domain identity must have sufficient privileges in the Windows Domain Active Directory to replicate the desired domain information to optimize encrypted traffic. To configure privileges, see [Configuring Microsoft Active Directory](#).

Step 4 Click the **Add Match Domain** button to add the child domains of the domain (with which the device is registered) for which the Domain Identity should optimize the encrypted traffic. You can add up to 32 child domains. If you do not want the Domain Identity to optimize the traffic for any of the child domains, you can delete the selected match domain items.



Note This is available only on devices running WAAS Version 5.4 and above.

Step 5 Click **OK**.

The domain identity appears in the Encrypted Services Domain Identities list ([Figure 12-4](#)).

Figure 12-4 Encrypted Services—Domain Identity

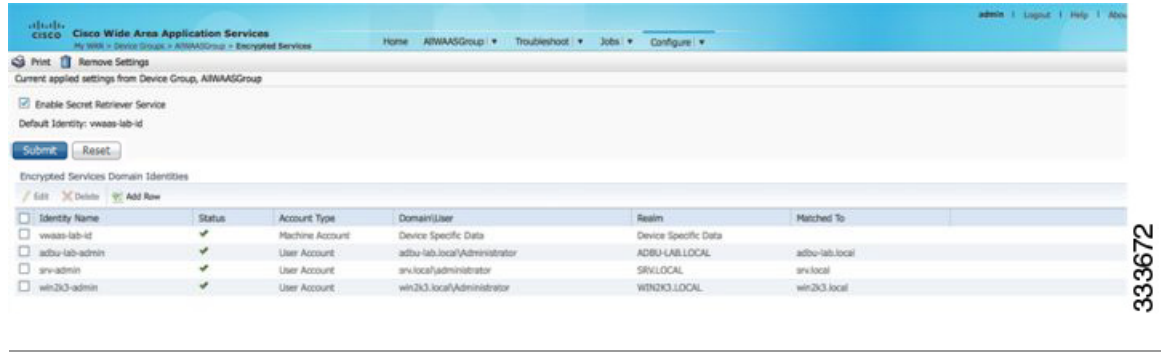

To configure and verify Encrypted Services Domain Identities from the CLI, use the **windows-domain encrypted-service** global configuration command and the **show windows-domain encrypted-service EXEC** command.

Creating and Configuring a User Account



Note

For definitions of user accounts and other Microsoft Active Directory terms, see [Terms Used with Microsoft Active Directory](#).

To create a user account and configure a user account identity, follow these steps:

- Step 1** From the WAAS Central Manager menu, choose **Devices** > *device-name* (or **Device Groups** > *device-group-name*).
- Step 2** From the menu, choose **Configure** > **Security** > **Windows Domain** > **Encrypted Services**. The Encrypted Services window appears (Figure 12-5).

Figure 12-5 Encrypted Services

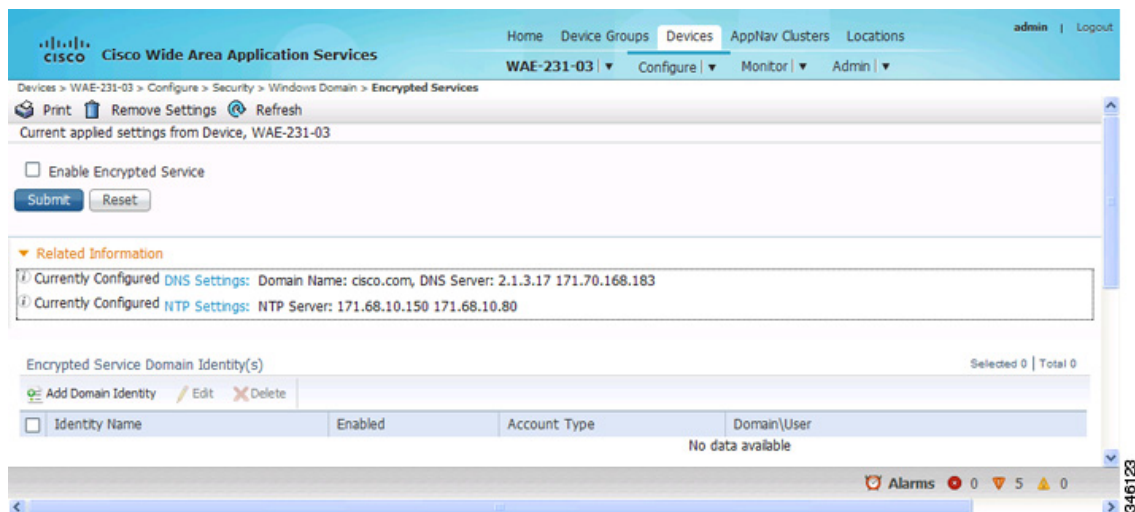

- Step 3** Click **Add Domain Identity** to add a user account domain identity.
The Domain Identity window appears (Figure 12-6).

Figure 12-6 Add Domain Identity—User Account

- a. Choose user account from the **Account Type** drop-down list.
- b. Enter the identity name in the Identity Name field. Only alphanumeric characters are allowed. Space, ?, and | are not allowed. The length is not to exceed 32 characters.
- c. Enter username and password.
- d. Enter the domain name.
- e. Enter the Kerberos realm.
- f. Click **Add Match Domain** to add the child domains of the selected domain, for which the Domain Identity should optimize the encrypted traffic. You can add up to 32 child domains. If you do not want the Domain Identity to optimize the traffic for any of the child domains, you can delete the selected match domain items.



Note The domain identity must have sufficient privileges in the Windows Domain Active Directory to replicate the desired domain information to optimize encrypted traffic. For information about configuring privileges, see [Configuring Microsoft Active Directory](#).

- Step 4** Click **OK**.
The domain identity appears in the Encrypted Services Domain Identities list.



Note Secure store encryption is used for the user account domain identity password. If secure store cannot be opened, an alarm is raised indicating that the configuration updates could not be stored on the device. After secure store can be opened and the configuration updates are successfully stored on the device, the alarm is cleared.

To configure and verify Encrypted Services Domain Identities from the CLI, use the **windows-domain encrypted-service** global configuration command and the **show windows-domain encrypted-service EXEC** command.

Configuring Microsoft Active Directory

To grant Cisco WAAS permission to accelerate Microsoft Exchange-encrypted email sessions, follow these steps:

-
- Step 1** Using an account with Domain Administrator privileges, launch the **Active Directory Users and Computers** application.
- Step 2** Create a new group.



Note This group is for accounts that WAAS will use to optimize Exchange traffic. Normal users and computers should not be added to this group.

- a. Right-click the **Unit** to contain the new group and choose **New > Group** ([Figure 12-7](#)).

Figure 12-7 Active Directory—Add Group

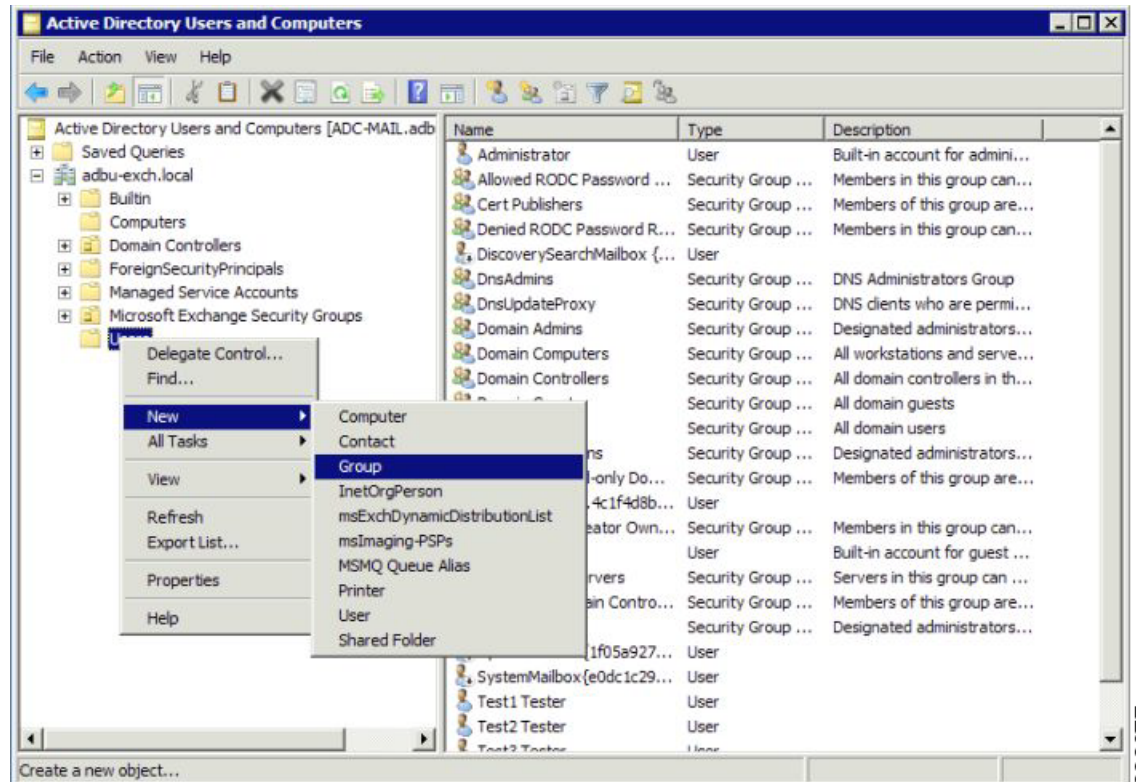

33367

- b. Enter a name in the Group name field and select the following attributes:
 - Group scope: Universal
 - Group type: Security
- c. Click **OK**.

Step 3 Configure the permissions required by WAAS.

- a. In the Active Directory Users and Computers application window, choose **View > Advanced Features** from the menu bar.
- b. Right-click the root of the domain and choose **Properties**.
- c. Click the **Security** tab (Figure 12-8).

Figure 12-8 Active Directory—Security Tab

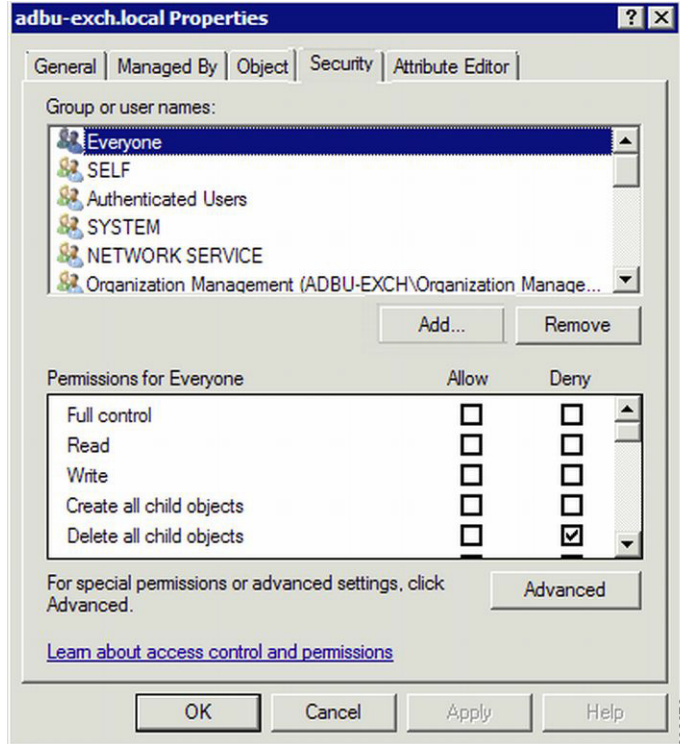

- d. Click **Add** in the Group or User Names section.
- e. Enter the name of the new group in the Enter the object names to select field.
- f. Click **OK** to add the new group to the list.
- g. Check the check box adjacent to the new group in the Group or user names list and set the following permissions to **Allow**:
 - Replicating Directory Changes
 - Replicating Directory Changes All
- h. Click **OK**.

Step 4 Add an account to the group.

User or workstation (computer) accounts must be added to the new group for WAAS Exchange Encrypted email optimization.

- a. Right-click on the account you want to add and select the **Member Of** tab.
- b. Click **Add**.
- c. Choose the new group you created and click **OK**.

Active Directory permissions configuration is complete.

Managing Domain Identities and Encrypted MAPI State

This section contains the following topics:

- [Editing an Existing Domain Identity](#)
- [Deleting an Existing Domain Identity](#)
- [Disabling Encrypted MAPI](#)
- [Encrypted MAPI Acceleration Statistics](#)

Editing an Existing Domain Identity

You can modify the attributes of an existing domain identity on a WAAS device, if needed.

**Note**

If the password for a user account has been changed in the Active Directory, you must edit the user account domain identity on the WAAS device to match the new Active Directory password. For definitions of user account and machine account identity, see [Terms Used with Microsoft Active Directory](#).

The following restrictions apply:

- For a machine account identity, only the state of the domain identity (enabled or disabled) can be modified from a WAAS device.
- For a user account identity, only the state of the domain identity (enabled or disabled) and the password can be modified from a WAAS device.

To change the password for a user account domain identity on a WAAS device when the password for the account in the Active Directory has changed, follow these steps:

-
- Step 1** From the WAAS Central Manager menu, choose **Devices** > *device-name* (or **Device Groups** > *device-group-name*).
 - Step 2** From the menu, choose **Configure** > **Security** > **Windows Domain** > **Encrypted Services**.
The Encrypted Services window appears.
 - Step 3** Select the user account domain identity to modify and click the **Edit** icon.
The Domain Identity window appears.
 - Step 4** Change the password in the Password field. The password should be the same as the password for the account in Active Directory.
 - Step 5** Click **OK**.
-

Deleting an Existing Domain Identity

To delete a domain identity on a WAAS device, follow these steps:

-
- Step 1** From the WAAS Central Manager menu, choose **Devices** > *device-name* (or **Device Groups** > *device-group-name*).
 - Step 2** From the menu, choose **Configure** > **Security** > **Windows Domain** > **Encrypted Services**.
The Encrypted Services window appears.
 - Step 3** Select one or more domain identities to delete and click the **Delete** icon to remove the domain identity configured on the WAAS device.
A warning message appears if the domain identity is being used for optimizing encrypted traffic.

- Step 4** Click **OK** to accept or **Cancel** to abort the procedure.
-

Disabling Encrypted MAPI

To disable Encrypted MAPI, follow these steps:

- Step 1** From the WAAS Central Manager menu, choose **Devices > device-name** (or **Device Groups > device-group-name**).
- Step 2** Disable Encrypted Service.
- a. From the menu, choose **Configure > Security > Windows Domain > Encrypted Services**.
The Encrypted Services window appears.
 - b. Uncheck the **Enable Encrypted Service** check box.
 - c. Click **Submit** to save your changes.
- Step 3** Disable Encrypted MAPI Traffic Optimization.
- a. From the menu, choose **Configure > Acceleration > Enabled Features**.
The Enabled Features window appears.
 - b. Uncheck the **Encrypted MAPI Traffic Optimization** check box.
 - c. Click **Submit** to save your changes.
-

Encrypted MAPI Acceleration Statistics

To view the statistics for Encrypted MAPI connections, see [Using Predefined Reports to Monitor WAAS](#) in Chapter 15, “Monitoring Your WAAS Network,” and see the MAPI acceleration reports.

Cisco WAAS MAPI RPC over HTTP(S)

RPC over HTTP allows Outlook clients to access Exchange servers from outside the enterprise network using HTTP or HTTPS as a transport for RPC protocol. It allows a client on the Internet to connect securely to a Microsoft Exchange Server without having to log into a virtual private network (VPN) first.

An RPC-HTTP (RPCH) module in WAAS, integrated into the existing WAAS MAPI optimizer will provide WAAS the ability to optimize MAPI over RPC-HTTP(S) traffic.

WAAS Version 6.2.x supports L7 optimization for RPCHTTP(S) traffic.

Microsoft Outlook and Exchange Versions Supported for Cisco WAAS MAPI RPC over HTTP(S)

[Table 12-2](#) shows the clients and servers supporting WAAS MAPI RPC over HTTP(S):

Table 12-2 *Clients and Servers Supporting WAAS MAPI RPC over HTTP(S)*

Clients Supported	Servers Supported
Outlook 2016	Exchange 2016
Outlook 2013 (for Windows 7 and Windows 8)	Exchange 2013 (for Windows Server 2012, 2012 R2, 2008 R2 [full installation])
Outlook 2010 (for Windows 7 and Windows 8)	Exchange 2010 (for Windows Server 2012, 2012 R2, 2008, and 2008 R2)
Outlook 2007 (for Windows Vista, Windows 7)	

Exchange 2013 and Exchange 2016 can be configured for MAPI over HTTP support. MAPI over HTTP traffic will not be optimized by MAPI accelerator. However, MAPI over HTTP traffic will get L4 optimization benefits from WAAS (THSDL).

Configuration pre-requisites for optimizing MAPI RPC over HTTP(S)

To enable optimization of MAPI RPC over HTTP(S), follow these steps:

-
- Step 1** Ensure that the SSL, HTTP and MAPI accelerators are enabled.
- Step 2** Configure SSL acceleration. For more information, see [Configuring SSL Acceleration](#).
- Step 3** When you configure SSL acceleration, be sure to enable protocol chaining, by checking the **Enable protocol chaining** check box on the SSL Accelerated Services window.
-  **Note** If protocol chaining is not enabled, the WAAS device will only optimize SSL traffic on the specified IP address and port.
-
- Step 4** Configure a windows domain identity on the core device, for encrypted MAPI connections.
- Step 5** Ensure encryption is enabled in MAPI accelerator. For more information, refer to [Configuring Encrypted MAPI Settings](#)
-

MAPI Acceleration Charts for Cisco WAAS MAPI RPC over HTTP(S)

The MAPI Acceleration report displays MAPI acceleration statistics. For WAAS Version 5.5.3 and above, the following MAPI acceleration charts are added or modified:

- **MAPI: Handled Traffic Pattern**—A new pie diagram that shows the three different types of traffic handled by the MAPI AO. For more information, see [MAPI: Handled Traffic Pattern](#) in Chapter 15, “Monitoring Your WAAS Network.”
- **MAPI: Connection Details**—An existing chart for MAPI session connection statistics, MAPI: Connection Details now includes a new classification for optimized TCP and RPC-HTTP(S) MAPI connections. For more information, see [MAPI: Connection Details](#) in Chapter 15, “Monitoring Your WAAS Network.”

Configuring SMB Acceleration

The SMB application accelerator handles optimizations of file server operations. These optimizations apply to SMBv1, SMBv2 and SMBv3. It can be configured to perform the following file server optimizations:

- **SMB Print Optimization**—A centralized print deployment reduces management overhead and increases cost savings. SMB Print Optimization optimizes print traffic by utilizing a centralized printer server, which resides in the data center. This removes the need for local print servers in the branches. The three most common uses for a centralized printer server are: to print from branch client to branch printer, to print from branch client to data center printer, and to print from data center client to branch printer.
- **Read Ahead Optimization**—The SMB accelerator performs a read-ahead optimization (SMBv1 only) on files that use the oplocks feature. When a client sends a read request for a file, it is likely that the accelerator may issue more read requests for the same file. To reduce the use of network bandwidth to perform these functions over the WAN on the file server, the SMB accelerator performs read-ahead optimization by proactively reading more file data than what has been initially requested by the client.
- **Directory Listing Optimization**—A significant portion of the traffic on the network is for retrieving directory listings. The SMB accelerator optimizes directory listings from the file server by prefetching. For directory prefetching, a request from the client is expanded to prefetch up to 64 KB of directory listing content. The SMB accelerator buffers the prefetched directory listing data until the client has requested all the data. If the directory listing size exceeds 64 KB, a subsequent request from the client is expanded by the SMB accelerator again to prefetch content up to 64 KB. This continues until all the entries of the directory are returned to the client.
- **Directory Browsing Optimization** - The SMB accelerator optimizes directory browsing by prefetching SMBv2 data from the file server and caching it in the RAM infrastructure of the WAE. When directory query requests are made by the client, the data is fetched from the cached data. To accommodate multiple client requests, locking mechanisms are in place while accessing parent directory and child files. Additionally, because the infrastructure has limited memory, new requests are cached only when memory is available.
- **Metadata Optimization**—The SMB accelerator optimizes fetching metadata from the file server through metadata prefetching. Additional metadata requests are tagged along with the client request and are sent to the file server to prefetch more information levels than what was requested by the client.
- **Named Pipe Optimization**—The SMB accelerator optimizes frequent requests from Windows Explorer to the file server to retrieve share, server, and workstation information. Each of these requests involves a sequence of operations that include opening and binding to the named pipe, making the RPC request, and closing the named pipe. Each operation incurs a round trip to the file server. To reduce the use of network bandwidth to perform these functions over the WAN on the file server, the SMB accelerator optimizes the traffic on the network by caching named pipe sessions and positive RPC responses.
- **Write Optimization**—The SMB accelerator performs write optimization by speeding up the write responses to the client by acknowledging the Write requests to the client whenever possible and, at the same time, streaming the Write requests over the WAN to the server.
- **Not-Found Metadata caching**—Applications sometimes send requests for directories and files that do not exist on file servers. For example, Windows Explorer accesses the Alternate Data Streams (ADS) of the file it finds. With negative Not-Found (NF) metadata caching, the full paths to those nonexistent directories and files are cached so that further requests for the same directories and files get local denies to save the round trips of sending these requests to the file servers.

- **DRE-LZ Hints**—The SMB accelerator provides DRE hints to improve system performance and resources utilization. At the connection level, the SMB accelerator uses the BEST_COMP latency sensitivity level for all connections, because it gives the best compression. At the message level, the SMB accelerator provides message-based DRE hints for each message to be transmitted over the WAN.
- **Microsoft Optimization**—The SMB accelerator optimizes file operations for Microsoft applications by identifying lock request sequences for file name patterns supported by Microsoft Office applications.
- **Invalid FID Optimization**—The SMB accelerator optimizes SMB2 and SMB3 clients by locally denying attempts to access files with invalid file handle values instead of sending such requests to the file servers.
- **Batch Close Optimization**—The SMB accelerator performs asynchronous file close optimizations on all SMB traffic.
- **Read Cache optimization**—The SMB accelerator optimizes read operations in SMB2 by caching read response data so that files can be served locally.
- **Write Optimization** —The SMB accelerator improves system performances by performing asynchronous write operations.
- **Signed Optimization** — The SMB accelerator provides L7 optimization of all SMB traffic.
- **SMB v3 Encrypted Optimization** - The SMB accelerator provides L7 optimization of encrypted SMB v3 traffic.

To enable the SMB accelerator, check the **SMB Accelerator** check box in the Enabled Features window.

To configure the SMB acceleration settings, follow these steps:

-
- Step 1** From the WAAS Central Manager menu, choose **Devices** > *device-name* (or **Device Groups** > *device-group-name*).
- Step 2** Choose **Configure** > **Acceleration** > **SMB Settings**.
The SMB Settings window appears ([Figure 12-9](#)).

Figure 12-9 SMB Accelerator Configuration Window

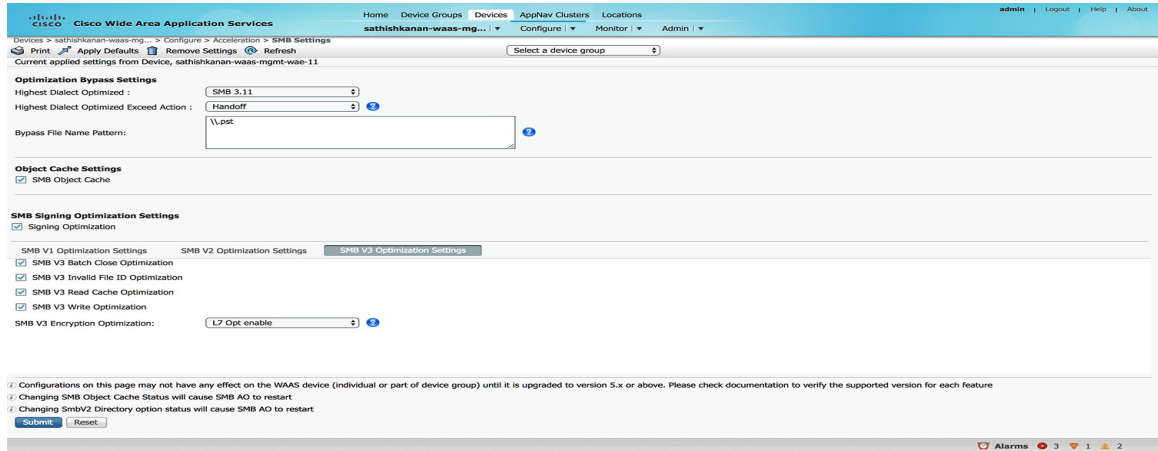

Step 3 From the **Highest Dialect Optimized** drop-down list, choose the highest dialect to optimize. The available options are:

- NTLM 0.12 or NTLM 1.0
- SMB 2.0
- SMB 2.1
- SMB 3.0
- SMB 3.02

Step 4 From the **Highest Dialect Optimized Exceed Action** drop-down list, choose the action for the dialects that are higher than the one chosen as the highest dialect to optimize:

- **Mute**—The dialects higher than the one chosen as the highest dialect to optimize are removed from the negotiation list. This is the default selection.

**Note**

The Mute option of SMB AO is deprecated in dialects 3.x and 2.0 of SMB; muting within these versions has been found to be unsuccessful in terms of optimization.

- **Handoff**—If the negotiated dialect is higher than the chosen highest dialect to optimize, the connection is handed off to the generic accelerator.

**Note**

For SMB 2.1 only, you must configure the Handoff parameter from the CLI using the **accelerator smb smb2-1 exceed-action handoff** global configuration command. If you use the Central Manager to select the Handoff parameter for SMB 2.1, the Highest Dialect Optimized Exceed Action will not take effect, and “Handoff” will not be displayed in commands like the **show running-configuration** command or the **show accelerator smb** command.

Step 5 In the Bypass File Name Pattern field, enter the patterns for the file names that you want the SMB accelerator to bypass optimization for. The files whose names match the specified expressions are not optimized.

Step 6 Check the SMB Object Cache check box if you want to enable disk caching for SMB traffic.

Step 7 Check the **Signing Optimization** check box to enable optimization of signed SMB v2 and v3 traffic. This check box is checked by default.

An SMB connection request can originate from the Branch office to the Data Center or vice-versa. For every connection, the WAE near the requestor, takes the Edge WAE's role and WAE near the smb server takes the Core WAE's role.

The following prerequisites, at the Core and Edge WAE, are necessary to ensure that a signed connection is optimized:

- a. On the Core WAE, configure a valid user-identity with administrator privileges to enable secret-retrieval to fetch and cache the long term service key of the smb server using the global configuration command:

```
(config)#windows-domain encryption-service identity [identity] user-account name  
[admin-username] domain <your.domain> realm [YOUR.DOMAIN] password
```

Verify the identity configuration by using the following EXEC Command.

```
sh windows-domain encryption-service identity detail
```

For Kerberos Authentication, ensure time synchronization between Client, Server, Core WAE and the Domain Controller.

If you want to verify if a connection is signed or not you can do so by looking into the **SMBv2 Negotiate** packet. The **Signing Required** field should be set to "True" in either the Negotiate Request or the Negotiate Response exchange.

These configurations are similar to the eAPI configuration. For more information, see Step 6 of [Configuring Encrypted MAPI Settings](#).

- b. Verify that the WAN Secure mode is enabled. WAN Secure's secure connection enables the key to be transported to the Edge WAE.

The default recommended mode is Auto. You can verify the state of WAN Secure mode using the following EXEC command:

```
show accelerator wansecure
```

If necessary, you can change the state of WAN Secure using the following global configuration command:

```
accelerator smb wansecure-mode {always | auto | none}
```

- c. Verify if the WAE devices are registered and are online with the WAAS Central Manager.

Step 8 Click the **SMBV1 Optimization Settings** tab to perform the following tasks:

- Check the **Meta Data Optimization** check box to enable metadata optimization. This check box is checked by default.
- Check the **Microsoft Office Optimization** check box to enable optimizations for all versions of Microsoft Office. The SMB accelerator does not perform read-ahead, write, and lock-ahead optimizations for Microsoft Office if this optimization is disabled. This check box is checked by default.
- Check the **Named Pipe Optimization** check box to enable named pipe optimization by caching named pipe sessions and positive RPS responses. This check box is checked by default.
- Check the **'Not Found' Cache Optimization** check box to enable caching pathnames of files not found. This check box is checked by default.
- Check the **Print Optimization** check box to enable SMB to configure a centralized print deployment. This check box is checked by default.

- Check the **Read Ahead Optimization** check box to enable the SMB to optimize the quantity of read-ahead data from the file. The SMB performs a read-ahead optimization only when the file is opened using the oplocks feature. This check box is checked by default.
- Check the **Write Optimization** check box to enable the write optimization by speeding up the write responses to the client. This check box is checked by default

Click **SMBV2 Optimization Settings** tab to perform the following tasks:

- Check the **Batch Close Optimization** check box to enable asynchronous files close optimizations. This check box is checked by default.
- Check the **Invalid FID Optimization** check box to enable optimization of files with invalid file handle values. This check box is checked by default.
- Check the **SMBV2 Read Cache Optimization** check box to enable read response caching. This check box is checked by default.
- Check the **SMBV2 Write Optimization** check box to enable asynchronous write operations. This check box is checked by default.
- Check the **Directory Service Optimization** check box to enable optimization of directory browsing performance for SMB v2 traffic. The check box is checked by default. Directory service optimization is available only on devices or device groups running software image 6.1.1.

Click **SMBV3 Optimization Settings** tab to perform the following tasks:

- Check the **SMB v3 Batch Close Optimization** check box to enable asynchronous files close optimizations. This check box is checked by default.
- Check the **SMB v3 Invalid FID Optimization** check box to enable optimization of files with invalid file handle values. This check box is checked by default.
- Check the **SMB v3 Read Cache Optimization** check box to enable read response caching. This check box is checked by default.
- Check the **SMB v3 Write Optimization** check box to enable asynchronous write operations. This check box is checked by default.
- Select the type of optimization you want from the **SMB v3 Encryption Optimization** drop down box - L7 Optimization, L4 only optimization or disable SMB v3 encrypted optimization. L7 optimization is selected by default.

Step 9 Click **Submit** to save the changes.

To configure SMB acceleration from the CLI, use the **accelerator smb** global configuration command.

Configuring ICA Acceleration

The Independent Computing Architecture (ICA) application accelerator provides WAN optimization on a WAAS device for ICA traffic that is used to access a virtual desktop infrastructure (VDI). This is done through a process that is both automatic and transparent to the client and server.

ICA acceleration is enabled on a WAAS device by default.

To enable the ICA accelerator, check the **ICA Accelerator** check box in the Enabled Features window (Figure 12-10).

To configure the ICA acceleration settings, follow these steps:

- Step 1** From the WAAS Central Manager menu, choose **Devices** > *device-name* (or **Device Groups** > *device-group-name*).
- Step 2** Choose **Configure** > **Acceleration** > **ICA Settings**.
The ICA Acceleration Configuration window appears.

Figure 12-10 ICA Acceleration Configuration Window

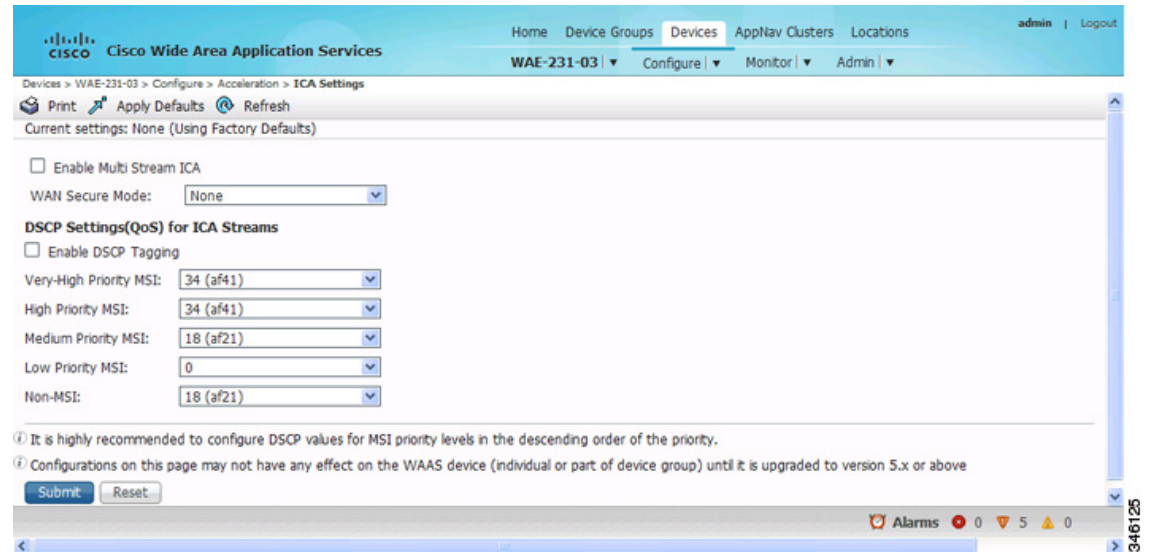

- Step 3** Check the **Enable Multi Stream ICA** check box to allow the client and server up to three additional TCP connections that optimize multistream ICA traffic.
- Step 4** From the **WAN Secure Mode** drop-down list, choose the mode. The options are:
- **None**—Disables WAN Secure mode for ICA. This is the default.
 - **Always**—Enables WAN Secure mode for ICA.



Note The state of WAN Secure mode in both Branch WAE and Data Center WAE must match for connections to get optimized with the ICA accelerator.

- Step 5** In the DSCP Settings (QoS) under ICA Streams section, check the **Enable DSCP Tagging** check box to configure DSCP values for MSI priority levels. These values override the defaults. The valid range is from 0 to 63.



Note Configure DSCP values for MSI priority levels in the descending order of the priority.

- a. Very High-Priority MSI—Typically real-time traffic, such as audio. The default is af41.
- b. High-Priority MSI—Typically interactive traffic. The default is af41.
- c. Medium-Priority MSI—Typically bulk data. The default is af21.
- d. Low-Priority MSI—Typically background traffic, such as printing. The default is 0—best effort.

- e. Non-MSI—(the default is af21)



Note MSI priority configuration might not apply to devices earlier than WAAS Version 5.1.x.

Step 6 Click **Submit**.

The changes are saved to the device or device group.

To configure ICA acceleration from the CLI, use the **accelerator ica** global configuration command.

To verify the status of WAN Secure mode from the CLI, use the **show accelerator wansecure EXEC** command.

Configuring ICA over SSL

The WAAS software supports optimizing ICA over SSL. This allows the client and server to use the ICA protocol over an encrypted connection. To support optimizing ICA over SSL, you must perform the following steps:

- Configure ICA acceleration. See [Configuring ICA Acceleration](#).
- Configure SSL acceleration. See [Configuring SSL Acceleration](#).



Note When you are configuring SSL acceleration, be sure to enable protocol chaining. If protocol chaining is not enabled, the WAAS device will only optimize SSL traffic on the specified IP Address and Port.

Configuring SSL Acceleration

The SSL (Secure Sockets Layer) application accelerator optimizes traffic on SSL encrypted connections. If SSL acceleration is not enabled, the WAAS software DRE optimizations are not very effective on SSL-encrypted traffic. The SSL application acceleration enables WAAS to decrypt and apply optimizations while maintaining the security of the connection.



Note On a WAAS Express device, only SSL cipher list, SSL certificate authorities, and SSL peering service configuration are supported.



Note The SSL accelerator does not optimize protocols that do not start their SSL/TLS handshake from the very first byte. The only exception is HTTPS that goes through a proxy (where the HTTP accelerator detects the start of SSL/TLS). In this case, both HTTP and SSL accelerators optimize the connection.

The SSL application accelerator supports SSL Version 3 (SSLv3) and Transport Layer Security Version 1 (TLSv1) protocols. If a TLSv1.1 or TLSv1.2 client request is received, negotiation will not occur. Manual bypass of TLSv1.1 or TLSv1.2 packets is required in order to make these client/server connections.

[Table 12-3](#) provides an overview of the steps you must complete to set up and enable SSL acceleration.

Table 12-3 Checklist for Configuring SSL Acceleration

Task	Additional Information and Instructions
1. Prepare for configuring SSL acceleration.	Identifies the information that you need to gather before configuring SSL acceleration on your WAAS devices. For more information, see Prerequisites for Configuring SSL Acceleration .
2. Enable secure store, the Enterprise License, and SSL acceleration.	Describes how to set up Central Manager secure store, how to enable the Enterprise License, and how to enable SSL acceleration. Secure store mode is required for secure handling of the SSL encryption certificates and keys. For more information, see Enabling Secure Store Encryption on the WAAS CM and Enabling Enterprise Licenses on the WAAS CM and WAEs .
3. Enable SSL application optimization.	Describes how to activate the SSL acceleration feature. For more information, see Enabling and Disabling the Global Optimization Features .
4. Configure SSL acceleration settings.	(Optional) Describes how to configure the basic setup of SSL acceleration. For more information, see Configuring SSL Global Settings .
5. Create and manage cipher lists.	(Optional) Describes how to select and set up the cryptographic algorithms used on your WAAS devices. For more information, see Working with Cipher Lists .
6. Set up CA certificates.	(Optional) Describes how to select, import, and manage certificate authority (CA) certificates. For more information, see Working with Certificate Authorities .
7. Configure SSL management services.	(Optional) Describes how to configure the SSL connections used between the Central Manager and WAE devices. For more information, see Configuring SSL Management Services .
8. Configure SSL peering service.	(Optional) Describes how to configure the SSL connections used between peer WAE devices for carrying optimized SSL traffic. For more information, see the Configuring SSL Peering Service .
9. Configure and enable SSL-accelerated services.	Describes how to add, configure, and enable services to be accelerated by the SSL application optimization feature. For more information, see Using SSL Accelerated Services .

Prerequisites for Configuring SSL Acceleration

This section contains the following topics for tasks to complete before you configure SSL acceleration:

- [Confirming Your Network Information](#)
- [Enabling Secure Store Encryption on the WAAS CM](#)
- [Enabling Enterprise Licenses on the WAAS CM and WAEs](#)
- [Enabling SSL Acceleration on WAAS Devices](#)

Confirming Your Network Information

Before you configure SSL acceleration, you should know the following information about your network:

- The services that you want to be accelerated on the SSL traffic
- The server IP address and port information
- The public key infrastructure (PKI) certificate and private key information, including the certificate common name and CA-signing information
- The cipher suites supported

- The SSL versions supported

Figure 12-11 shows how the WAAS software handles SSL application optimization.

Figure 12-11 SSL Acceleration Block Diagram

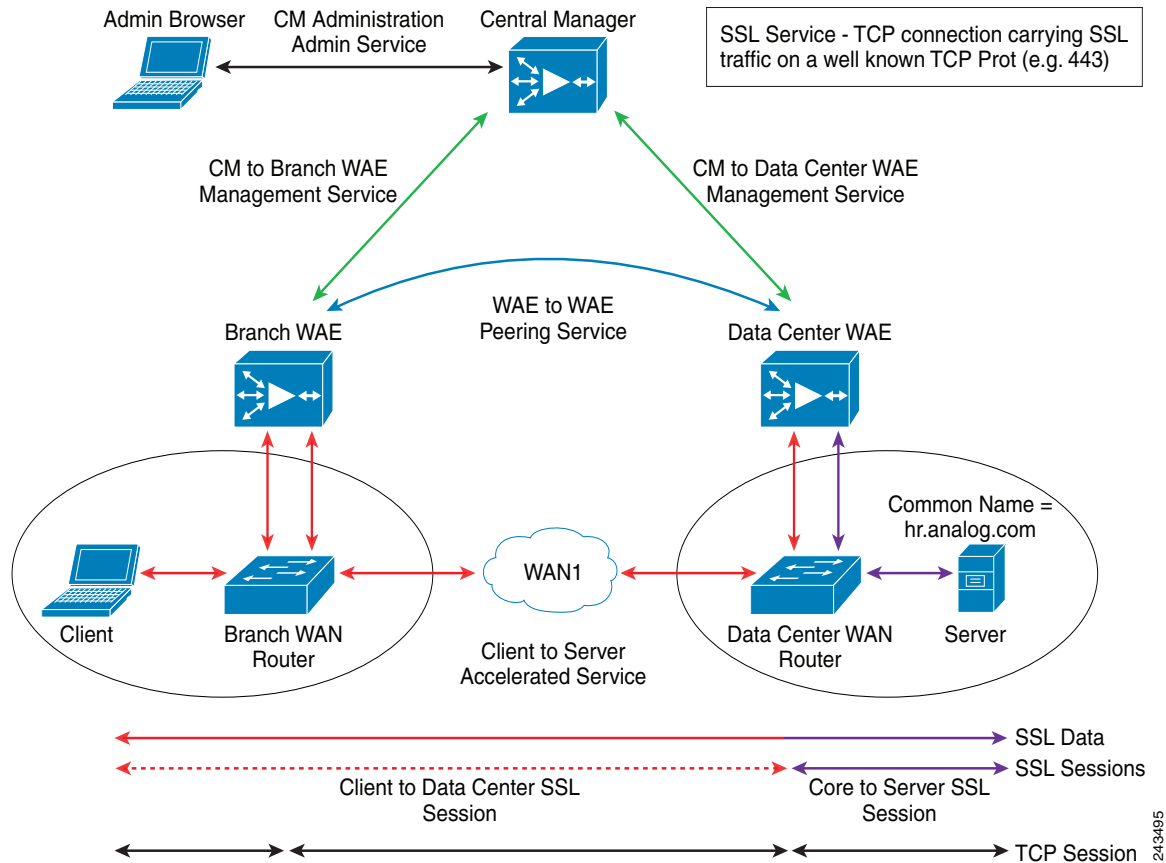

When you configure SSL acceleration, you must configure SSL-accelerated service on the server-side (Data Center) WAE devices. The client-side (Branch) WAE should have its secure store initialized and unlocked or opened, but does not have to have the SSL-accelerated service configured. However, the SSL accelerator must be enabled on both Data Center and Branch WAEs for SSL acceleration services to work. The WAAS Central Manager provides SSL management services and maintains the encryption certificates and keys.

Enabling Secure Store Encryption on the WAAS CM

Before you can use SSL acceleration on your WAAS system, you must enable secure store encryption on the WAAS CM. For more information on this procedure, see [Configuring Secure Store Settings](#) in Chapter 10, “Configuring Other System Settings.”

Enabling Enterprise Licenses on the WAAS CM and WAEs

Before you can use SSL acceleration on your WAAS system, you must enable the Enterprise license. For more information on this procedure, see [Managing Software Licenses](#) in Chapter 10, “Configuring Other System Settings.”

Enabling SSL Acceleration on WAAS Devices

Before you can use SSL acceleration on your WAAS system, you must enable SSL acceleration on WAAS devices. For more information on this procedure, see [Enabling and Disabling the Global Optimization Features](#).



Note

If the SSL accelerator is already running, you must wait for two datafeed poll cycles to be completed when registering a new WAE with a Central Manager before making any configuration changes. Otherwise the changes may not take effect.

Configuring SSL Global Settings

To configure the SSL acceleration global settings, follow these steps:

- Step 1** From the WAAS Central Manager menu, choose **Devices** > *device-name* (or **Device Groups** > *device-group-name*).
- Step 2** Choose **Configure** > **Security** > **SSL** > **Global Settings**.
The SSL Global Settings window appears ([Figure 12-12](#)).

Figure 12-12 SSL Global Settings Window

The screenshot shows the 'SSL Global Settings' window for a specific WAE. The window title is 'SSL Global Settings for WAE, wae04-07-psirt2-br-wae1'. It contains several sections:

- SSL version:** A dropdown menu set to 'All'.
- Revocation settings:** Includes a 'Revocation check' dropdown set to 'Disabled', an 'Ignore OCSP failures' checkbox, and an 'OCSP Responder URL' text field.
- Cipher List:** A dropdown menu set to 'Default' and a 'Create New' button.
- CipherList Configured:** A text field containing 'Default'.
- Cipher list Configured:** A table with columns for 'Priority' and 'Cipher'. The table lists several cipher suites with their priorities.
- Certificate and private key:** A section with four links: 'Generate self-signed certificate and private key', 'Import existing certificate and optionally private key', 'Export certificate and key', and 'Generate certificate signing request'.

At the bottom, there is a 'Note: * - Required field' and 'Submit' and 'Cancel' buttons.

Priority	Cipher
1	dhe-rsa-with-aes-256-cbc-sha
1	rsa-with-aes-256-cbc-sha
1	dhe-rsa-with-aes-128-cbc-sha
1	rsa-with-aes-128-cbc-sha
1	dhe-rsa-with-3des-ede-cbc-sha
1	rsa-with-3des-ede-cbc-sha
*	...

- Step 3** To configure a device to use the SSL settings from a particular device group, choose the device group from **Select a Device Group** drop-down list located in the SSL global settings toolbar. A device can either use its own SSL settings, or SSL settings from a device group. However, it is not possible to configure a device to use SSL settings from multiple device groups.



Note If you have configured the device with specific SSL Accelerated Services and assigned it to a Device Group, those configurations are lost when you click on the **Override Group Settings** on the **Device Group > Configure > Security > SSL > Global Settings** page.

- Step 4** From the SSL version drop-down list, choose the type of SSL protocol to use. Choose **SSL3** for the SSL Version 3 protocol, choose **TLS1** for the Transport Layer Security Version 1 protocol, or choose **All** to accept both SSL3 and TLS1 SSL protocols.
- Step 5** (Optional) Set the Online Certificate Status Protocol (OCSP) parameters for certificate revocation:
- From the OCSP Revocation check drop-down list, choose the OCSP revocation method.
Choose **ocsp-url** SSL accelerator to use OCSP responder specified in the **OCSP Responder URL** field to check the revocation status of certificates. Choose **ocsp-cert-url** to use the OCSP responder URL specified in the Certificate Authority.
 - If the **Ignore OCSP failures** check box is enabled, the SSL accelerator will treat the OCSP revocation check as successful if it does not get a definite response from the OCSP responder.
- Step 6** From the Cipher List drop-down list, choose a list of cipher suites to be used for SSL acceleration. For more information, see [Working with Cipher Lists](#).
- Step 7** Choose a certificate/key pair method ([Figure 12-13](#)).

Figure 12-13 Configuring Service Certificate and Private Key



- Click **Generate Self-signed Certificate Key** to have the WAAS devices use a self-signed certificate/key pair for SSL.
- Click **Import Existing Certificate Key** to upload or paste an existing certificate/key pair.
- Click **Export Certificate Key** to export the current certificate/key pair.
- Click **Generate Certificate Signing Request** to renew or replace the existing certificate/key pair. The certificate signing request is used by the CA to generate a new certificate.



Note The file that you import or export must be in either a PKCS12 format or a PEM format.

- Click **Import existing client certificate and optionally private key** to use the client configured certificate.

For information about service certificate and private key configuration, see [Configuring a Service Certificate and Private Key](#).

Step 8 Click **Submit**.

Configuring a Service Certificate and Private Key

To configure a service certificate and private key, follow these steps:

Step 1 To generate a self-signed certificate and private key ([Figure 12-14](#)), follow these steps:

Figure 12-14 Self-Signed Certificate and Private Key

[Generate self-signed certificate and private key](#)

Mark private key as exportable

Key Size:* 1024

Common Name:* server.domain.com

Organization: Cisco Systems

Organization Unit: WAAS

Location: San Jose

State: California

Country: US

Email: name@domain.com

Expires in:* 365

Generate Cancel

243841

- Check the **Mark private key as exportable** check box to export this certificate/key in the WAAS Central Manager and device CLI later.
- Fill in the certificate and private key fields.
- Operating Considerations for **Key Size** field:
 - For WAAS Version 6.1.x and earlier, the **Key Size** drop-down list values are 512, 768, 1024, 1536, and 2048.

**Note**

A self-signed certificate on WAAS Version 6.1.x or earlier with an RSA modulus size of 512 is *not* compatible with Mozilla FireFox Version 39 and later, or with Google Chrome Version 48 and later. A self-signed certificate on WAAS Version 6.1.x or earlier with an RSA modulus size of 512 *is* compatible with Internet Explorer 8 and later.

If you have previously configured the RSA modulus size as 512: to access the WAAS CM with Mozilla FireFox Version 39 and later, or with Google Chrome Version 48 and later, you must regenerate the self-signed certificate with an RSA modulus size of **2048**, and then upgrade to the specified version of Mozilla FireFox or Google Chrome.

- For WAAS Version 6.2.x and later, the **Key Size** drop-down list values are 768, 1024, 1536, and 2048. The key size 512 is *not* used with WAAS Version 6.2.x and later.

Step 2 To import an existing certificate or certificate chain and, optionally, private key (Figure 12-15), follow these steps:

**Note**

The Cisco WAAS SSL feature only supports RSA signing/encryption algorithm and keys.

Figure 12-15 Importing Existing Certificate or Certificate Chain

- Check the **Mark private key as exportable** check box to export this certificate/key in the WAAS Central Manager and device CLI later.
- To import existing certificate or certificate chain and private key, perform one of the following tasks:
 - Upload the certificate and key in PKCS#12 format (also as known Microsoft PFX format)
 - Upload the certificate and private key in PEM format
 - Paste the certificate and private key PEM content

If the certificate and private key are already configured, you can update only the certificate. In this case, the Central Manager constructs the certificate and private key pair using the imported certificate and current private key. This functionality can be used to update an existing self-signed certificate to one signed by the CA, or to update an expiring certificate.

The Central Manager allows importing a certificate chain consisting of an end certificate that must be specified first, a chain of intermediate CA certificates that sign the end certificate or intermediate CA certificate, and end with a root CA.

The Central Manager validates the chain and rejects it if the validity date of the CA certificate is expired, or the signing order of certificates in the chain is not consequent.

- c. Enter a pass-phrase to decrypt the private key, or leave this field empty if the private key is not encrypted.

Step 3 To export a configured certificate and private key (Figure 12-16), follow these steps:

Figure 12-16 Export Certificate and Key

- a. Enter the encryption pass-phrase.
- b. Export current certificate and private key in either PKCS#12 or PEM formats. In the case of PEM format, the both certificate and private key are included in single PEM file.



Note Central Manager will not allow the export of certificate and private key if the certificate and key were marked as nonexportable when they were generated or imported.

Step 4 To generate a certificate-signing request from a current certificate and private key (Figure 12-17), follow these steps:

Figure 12-17 Generate Certificate-Signing Request

- Step 5** To update the current certificate with one signed by the Certificate Authority:
- Generate PKCS#10 certificate signing request.
 - Send generated certificate signing request to Certificate Authority to generate and sign certificate.
 - Import certificate received from the Certificate Authority using the **Importing existing certificate and optionally private key** option.



Note The size of the key for a generated certificate request is the same as the size of the key in the current certificate.

- Step 6** To import an existing client certificate or certificate chain and, optionally, private key (Figure 12-18), follow these steps:

Figure 12-18 Import existing client certificate and optionally private key

- Check the **Mark private key as exportable** check box to export this certificate/key in the WAAS Central Manager and device CLI later.
- To import existing client certificate and private key, perform one of the following:
 - Upload certificate and key in PKCS#12 format (also as Microsoft PFX format)
 - Upload certificate and private key in PEM format
 - Paste certificate and private key PEM content

If the certificate and private key are already configured, you can update the certificate only. In this case, the Central Manager constructs the certificate and private key pair using the imported client certificate and current private key. This functionality can be used to update an existing self-signed certificate to one signed by the Certificate Authority, or to update an expiring certificate.

The Central Manager allows importing a certificate chain consisting of an end certificate that must be specified first, a chain of intermediate CA certificates that sign the end certificate or intermediate CA certificate, and end with a root CA.

- Enter a pass-phrase to decrypt the private key, or leave this field empty if the private key is not encrypted.

- d. Click **Choose File** to navigate to the client configured certificate and **Import Client Cert** to successfully import the above certificate.

Working with Cipher Lists

Cipher lists are sets of cipher suites that you can assign to your SSL acceleration configuration. A cipher suite is an SSL encryption method that includes the key exchange algorithm, the encryption algorithm, and the secure hash algorithm.

To configure a cipher list, follow these steps:

Step 1 From the WAAS Central Manager menu, choose **Devices** > *device-name* (or **Device Groups** > *device-group-name*).

Step 2 Choose **Configure** > **Security** > **SSL** > **Cipher Lists**.

The SSL Cipher Lists window appears (Figure 12-19).



Note For a WAAS Express device, the SSL Cipher Lists window shows the same name and cipher fields, but in a slightly different format.

Figure 12-19 SSL Cipher Lists Window

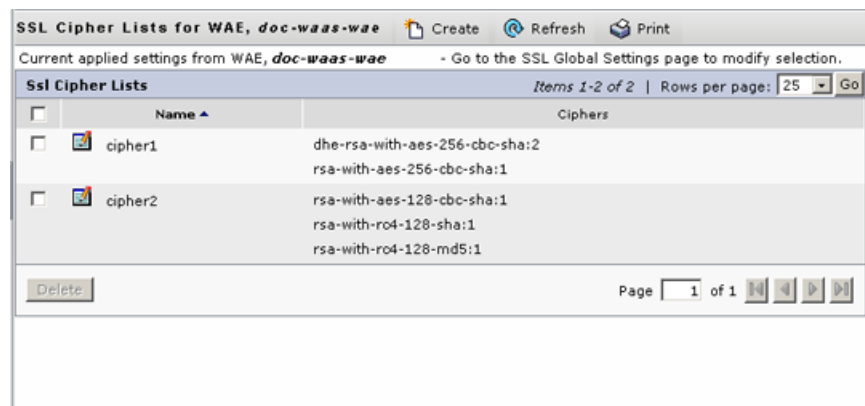

Step 3 Click **Create** to add a new cipher list.

The Creating New SSL Cipher List window appears (Figure 12-20).



Note For a WAAS Express device, click **Add Cipher List** to add a new cipher list.

Figure 12-20 Creating New SSL Cipher List Window

Creating new Ssl Cipher List, Ssl Cipher List

Ssl Cipher List

CipherList Name: * cipher-list1

Add New Cipher

Priority: * 1 Ciphers: * rsa-with-aes-256-cbc-sha

Cipher list Configured

<input type="checkbox"/>	Priority	Cipher
<input type="checkbox"/>	1	dhe-rsa-with-aes-256-cbc-sha

Note: * - Required Field

243825

Step 4 Type a name for your cipher list in the Cipher List Name field.

Step 5 Click **Add Cipher** to add cipher suites to your cipher list.



Note For a WAAS Express device, select the ciphers you wish to add, skip to [Step 12](#).

Step 6 From the Ciphers drop-down list, choose the cipher suite that you want to add.



Note If you are establishing an SSL connection to a Microsoft IIS server, do not select a DHE-based cipher suite.

Step 7 Choose the priority for the selected cipher suite in the Priority field.



Note When SSL peering service is configured, the priority associated with a cipher list on a core device takes precedence over the priority associated with a cipher list on an edge device.

Step 8 Click **Add** to include the selected cipher suite on your cipher list, or click **Cancel** to leave the list as it is.

Step 9 Repeat [Step 5](#) through [Step 8](#) to add more cipher suites to your list as desired.

Step 10 (Optional) To change the priority of a cipher suite, check the cipher suite check box and then use the up or down arrow buttons located below the cipher list to prioritize.

**Note**

The client-specified order for ciphers overrides the cipher list priority assigned here if the cipher list is applied to an accelerated service. The priorities assigned in this cipher list are only applicable if the cipher list is applied to SSL peering and management services.

- Step 11** (Optional) To remove a cipher suite from the list, check the cipher suite's box and then click **Delete**.
- Step 12** Click **Submit** when you are done configuring the cipher list.

**Note**

For a WAAS Express device, click **OK** to save the cipher list configuration.

SSL configuration changes will not be applied on the device until the security license has been enabled on the device.

Working with Certificate Authorities

The WAAS SSL acceleration feature allows you to configure the CA certificates used by your system. You can use one of the many well-known CA certificates included with WAAS, or import your own CA certificate.

To manage your CA certificates, follow these steps:

- Step 1** From the WAAS Central Manager menu, choose **Devices** > *device-name* (or **Device Groups** > *device-group-name*).
- Step 2** Choose **Configure** > **Security** > **SSL** > **Certificate Authorities**.

The SSL CA Certificate List window appears (Figure 12-21).

**Note**

For a WAAS Express device, the SSL CA Certificate List window shows the same Name, Issued To, Issuer, and Expiry Date fields, but in a slightly different format.

There is also an **Aggregate Settings** field configurable as Yes or No. To finish the procedure for WAAS Express, skip to [Step 4](#).

Figure 12-21 SSL CA Certificate List Window



- Step 3** Add one of the preloaded CA certificates that is included with WAAS as follows:
- Click **Well-known CAs**.

- b. Choose the pre-existing CA certificate you want to add and click **Import**. The CA certificate that you selected is added to the list on the SSL CA Certificate List display.

Step 4 Add your own CA certificate as follows:

- a. Click **Create**.

The Creating New CA Certificate window appears (Figure 12-22).



Note

For a WAAS Express device, click **Add CA** to add your own CA certificate. Enter the name and the URL, and then click **Get CA Certificate**. After this, skip to [Step 6](#).

Figure 12-22 Creating New CA Certificate Window

- b. Type a name for the certificate in the Certificate Name field.
- c. (Optional) Type a description of the CA certificate in the Description field.
- d. From the **Revocation check** drop-down list, choose **Disable** to disable OCSP revocation of certificates signed by this CA. Check the **Ignore OCSP failures** check box to mark revocation check successful if the OCSP revocation check failed.
- e. Add the certificate information by choosing one of the following methods:
 - **Upload PEM File**
If you are uploading a file, it must be in a PEM format. Browse to the file that you want to use and click **Upload**.
 - **Paste PEM-encoded Certificate**
If you are pasting the CA certificate information, paste the text of the PEM format certificate into the Paste PEM-encoded certificate field.
 - **Get CA Certificate using SCEP**

This option automatically configures the certificate authority using Simple Certificate Enrollment Protocol (SCEP). If you are using the automated certificate enrollment procedure, enter the CA URL and click **Get Certificate**. The contents of the certificate are displayed in text and PEM formats.

To complete the automated certificate enrollment procedure, configure the SSL auto enrollment settings in [Configuring SSL Auto Enrollment](#).

f. Click **Submit** to save your changes.

Step 5 (Optional) To remove a CA from the list, select it and then click the **Delete** icon located in the toolbar.

Step 6 Click **Submit** after you are done configuring the CA certificate list.



Note For a WAAS Express device, click **OK** to save the CA certificate configuration.

Configuring SSL Auto Enrollment

The WAAS SSL acceleration feature allows you to enroll certificates automatically for a device (or device group) using SCEP. After the CA certificate is obtained, configure the SSL auto enrollment settings.



Note You must configure the CA authority before configuring auto enrollment settings.

To configure SSL auto enrollment settings, follow these steps:

Step 1 From the WAAS Central Manager menu, choose **Devices** > *device-name* (or **Device Groups** > *device-group-name*).

Step 2 Choose **Configure** > **Security** > **SSL** > **Auto Enrollment**.

The SSL Auto Enrollment Settings window appears ([Figure 12-23](#)).

Figure 12-23 SSL Auto Enrollment Settings Window

The screenshot displays the 'SSL Auto Enrollment Settings' window in the Cisco WAE interface. The breadcrumb trail is 'Devices > wae-231-02 > Configure > Security > SSL > Auto Enrollment'. The current settings are for WAE 'wae-231-02'. The 'CA settings' section includes a text field for 'CA URL', a dropdown for 'CA' (set to 'None'), and a text field for 'Challenge Password'. The 'Certificate Signing Request' section includes text fields for 'Common Name', 'Organization', 'Organization Unit', 'Location', 'State', 'Country', and 'Email-Id'. The 'Key Size' section has a dropdown menu set to '1024'. The 'Enroll' section has an 'Enable Enroll' checkbox that is unchecked. At the bottom, there are 'Submit' and 'Cancel' buttons. A vertical ID number '333674' is visible on the right side of the screenshot.

Step 3 Configure the following CA settings:

- CA URL
- CA—Select the appropriate CA from the drop-down list
- Challenge Password



Note CA, CA URL, and Challenge Password are mandatory for enabling SSL auto enrollment.

Step 4 Configure the following Certificate Signing Request settings:

- Common Name
- Organization and Organization Unit
- Location, State, and Country
- Email-Id

Step 5 From the Key Size drop-down list, choose the key size. Valid values are 512, 768, 1024, 1536, or 2048.

Step 6 Check the **Enable Enroll** box.

Step 7 Click **Submit**.

You can then check the enrollment status in the Machine Certificate section on the SSL Global Settings page and on the Alerts page.

Configuring SSL Management Services

SSL management services are the SSL configuration parameters that affect secure communications between the Central Manager and the WAE devices (Figure 12-11). The certificate/key pairs used are unique for each WAAS device. Therefore, SSL management services can only be configured for individual devices, not device groups.

To configure SSL management services, follow these steps:

- Step 1** From the WAAS Central Manager menu, choose **Devices** > *device-name*.
- Step 2** Choose **Configure** > **Security** > **Management Service**.
The Management Services window appears (Figure 12-24).

Figure 12-24 SSL Management Services Window

Priority	Cipher
1	dhe-rsa-with-aes-256-cbc-sha
1	rsa-with-aes-256-cbc-sha
1	dhe-rsa-with-aes-128-cbc-sha
1	rsa-with-aes-128-cbc-sha
1	dhe-rsa-with-3des-ede-cbc-sha
1	rsa-with-3des-ede-cbc-sha
1	...

- Step 3** From the SSL version drop-down list, choose the type of SSL protocol to use. Choose **SSL3** for the SSL version 3 protocol, **TLS1** for the Transport Layer Security version 1 protocol, or **All** to use both SSL3 and TLS1 SSL protocols.



Note Management-service SSL version and cipher settings configured for the WAAS Central Manager are also applied to SSL connections between the WAAS Central Manager and the browser of the user.

Primary and standby Central Managers must share a common management service version or cipher list. Changing the management service version and cipher list settings may result in a loss of connectivity between the primary Central Manager and the standby Central Manager and WAE devices.

The following cipher lists are supported in SSL Acceleration (Legacy SSL Acceleration).

- `dhe-rsa-with-aes-256-cbc-sha`
- `rsa-with-aes-256-cbc-sha`
- `dhe-rsa-with-aes-128-cbc-sha`
- `rsa-with-aes-128-cbc-sha`
- `dhe-rsa-with-3des-ede-cbc-sha`
- `rsa-with-3des-ede-cbc-sha`
- `rsa-with-rc4-128-sha`
- `rsa-with-rc4-128-md5`
- `dhe-rsa-with-des-cbc-sha`
- `rsa-export1024-with-rc4-56-sha`
- `rsa-export1024-with-des-cbc-sha`
- `dhe-rsa-export-with-des40-cbc-sha`
- `rsa-export-with-des40-cbc-sha`
- `rsa-export-with-rc4-40-md5`
- `rsa-with-des-cbc-sha`



Note In case you need to configure additional ciphers, see the supported ciphers in [Preparing to use SMART-SSL acceleration/ SSL Accelerator v2](#).



Note All browsers support SSLv3 and TLSv1 protocols, but TLSv1 may not be enabled by default on certain browsers. Therefore, you must enable it in your browser.

Configuring ciphers or protocols that are not supported in your browser will result in connection loss between the browser and the Central Manager. If this occurs, configure the Central Manager management service SSL settings to the default in the CLI to restore the connection.

Some browsers, such as Internet Explorer, do not correctly handle a change of SSL version and cipher settings on the Central Manager, which can result in the browser showing an error page after you submit the changes. If this occurs, reload the page.

- Step 4** In the Cipher List pane, choose a list of cipher suites to be used for SSL acceleration. See [Working with Cipher Lists](#) for additional information.
-

Configuring SSL Admin Service

You can export the SSL CA signed certificate to enable trusted SSL communication between the WAAS Central Manager and the web browser. The default certificate for enabling SSL communication is the WAAS Central Manager self signed certificate. However, if you would like to use a different certificate, you need to configure it.

To configure the SSL certificate, follow these steps:

Step 1 From the WAAS Central Manager menu, choose **Devices>CM>Configure> Security> SSL Admin Service**.

The default certificate is displayed.

Step 2 Select the PKI operation

- a. Click Import Existing Certificate Key to upload or paste an existing certificate/key pair.
- b. Click Export Certificate Key to export the current certificate/key pair.
The file that you import or export must be in either a PKCS12 format or a Privacy Enhanced Mail (PEM) format.
- c. Click Generate Self-signed Certificate Key to have the Central Manager and WAAS device use a self-signed certificate/key pair for SSL.

Operating Considerations for **Key Size** field:

- For WAAS Version 6.1.x and earlier, the **Key Size** drop-down list values are 512, 768, 1024, 1536, and 2048.



Note

A self-signed certificate on WAAS Version 6.1.x or earlier with an RSA modulus size of 512 is *not* compatible with Mozilla FireFox Version 39 and later, or with Google Chrome Version 48 and later. A self-signed certificate on WAAS Version 6.1.x or earlier with an RSA modulus size of 512 *is* compatible with Internet Explorer 8 and later.

If you have previously configured the RSA modulus size as 512: to access the WAAS CM with Mozilla FireFox Version 39 and later, or with Google Chrome Version 48 and later, you must regenerate the self-signed certificate with an RSA modulus size of **2048**, and then upgrade to the specified version of Mozilla FireFox or Google Chrome.

- For WAAS Version 6.2.x and later, the **Key Size** drop-down list values are 768, 1024, 1536, and 2048. The key size 512 is *not* used with WAAS Version 6.2.x and later.

Step 3 Click Submit to register the certificate.

The Central Manager now uses the selected certificate for SSL communication.

Configuring SSL Peering Service

SSL peering service configuration parameters control the secure communications established by the SSL accelerator between WAE devices while optimizing SSL connections (Figure 12-11). The peering service certificate and private key is unique for each WAAS device and can only be configured for individual devices, not device groups.

To configure SSL peering service, follow these steps:

Step 1 From the WAAS Central Manager menu, choose **Devices > device-name**.

Step 2 Choose **Configure > Security > Peering Service**.

The Peering Service window appears (Figure 12-25).



Note For a WAAS Express device, the Peering Service window shows a subset of the fields in the standard Peering Service window in a slightly different format.

The cipher list **Priority** setting and the **Disable revocation check of peer certificates** options are not applicable to WAAS Express.

Figure 12-25 SSL Peering Service Window

Priority	Cipher
1	dhe-rsa-with-aes-256-cbc-sha
1	rsa-with-aes-256-cbc-sha
1	dhe-rsa-with-aes-128-cbc-sha
1	rsa-with-aes-128-cbc-sha
1	dhe-rsa-with-3des-ede-cbc-sha
1	rsa-with-3des-ede-cbc-sha
1	rsa-with-128-sha

- Step 3** From the SSL Version drop-down list, choose the type of SSL protocol to use, or choose **Inherited** to use the SSL protocol configured in global SSL settings. Choose **SSL3** for the SSL version 3 protocol, **TLS1** for the Transport Layer Security version 1 protocol, or **All** to use both SSL3 and TLS1 SSL protocols.



Note In a WAAS Express device, only SSL3 and TLS1 are supported for the SSL version.

- Step 4** To enable verification of peer certificates, check the **Enable Certificate Verification** check box. If certificate verification is enabled, WAAS devices that use self-signed certificates will not be able to establish peering connections to each other and, thus, not be able to accelerate SSL traffic.
- Step 5** Check the **Disable revocation check for this service** check box to disable OCSP certificate revocation checking.



Note In a WAAS Express device, this option is not available.

- Step 6** In the Cipher List pane, choose a list of cipher suites to be used for SSL acceleration between the WAE device peers, or choose **Inherited** to use the cipher list configured in SSL global settings.



Note In a WAAS Express device, the list of cipher suites to be used for SSL acceleration is shown in the Cipher List pane.

For more information, see [Working with Cipher Lists](#).

Step 7 Click **Submit**.



Note In a WAAS Express device, SSL configuration changes will not be applied on the device until the security license has been enabled on the device.

Using SSL Accelerated Services

After you have enabled and configured SSL acceleration on your WAAS system, you must define at least one service to be accelerated on the SSL path. To configure SSL-accelerated services, follow these steps:

-
- Step 1** From the WAAS Central Manager menu, choose **Devices** > *device-name* (or **Device Groups** > *device-group-name*).
 - Step 2** Choose **Configure** > **Acceleration** > **SSL Accelerated Services**.
 - Step 3** To delete an accelerated service, select the service and click **Delete**.
 - Step 4** Click **Create** to define a new accelerated service. A maximum of 512 accelerated services are allowed. The Basic SSL Accelerated Services Configuration window appears ([Figure 12-26](#)).

Figure 12-26 *SSL-Accelerated Services—Basic Window*

SSL Accelerated Service

Basic | Advanced

This service is bound to 'SSL' application policy. The optimization actions accelerating traffic matching this service are DRE, LZ and TFO.

Service Name: *

In service:

Client version rollback check:

Enable protocol chaining:

Match Server Name Indication:

Description:

Server addresses

Please specify the IP Address, Hostname or Domain of an accelerated server. Use 'Any' keyword to match any server IP Address. Note that hostname and domain server address types are only supported on devices using WAAS versions 4.2.X or later.

It is recommended to have maximum 32 server entries and up to 64 characters per entry. The combined length of all the server address:port entries should not exceed 2048 characters.

Server: IPAddress | Server Port: | Add

Type	Address	Port

Delete

Server Certificate and private key

[Generate self-signed certificate and private key](#)

[Import existing certificate and optionally private key](#)

[Export certificate and key](#)

[Generate certificate signing request](#)

Optional Client Certificate and private key

[Import existing client certificate and optionally private key](#)

Note: * - Required Field

Submit Cancel

Alarms 3

- Step 5** Enter a name for the service in the Service Name field.
- Step 6** To enable this accelerated service, check the **In service** check box.
- Step 7** To enable client version rollback check, check the **Client version rollback check** check box.
Enabling the client version rollback check does not allow connections with an incorrect client version to be optimized.
- Step 8** To match subject alternative names, enable the **Match Server Name Indication** check box. For more information, see [Configuring SSL Acceleration for SaaS Applications](#).
- Step 9** To enable protocol chaining, check the **Enable protocol chaining** check box.
Enabling protocol chaining allows other protocols to be optimized over SSL.
- Step 10** (Optional) Type a description of the service in the Description field.
- Step 11** From the Server drop-down list, choose **IP Address**, **Hostname**, or **Domain** as the SSL service endpoint type.
- Step 12** Type the server IP address (or proxy IP address), hostname, or domain of the accelerated server. Use the keyword **Any** to specify any server IP address.



Note A maximum of 32 IP addresses, 32 hostnames, and 32 domains are allowed.



Note Hostname and domain server address types are supported only when using WAAS software Version 4.2.x or later. Server IP address keyword **Any** is supported only when using WAAS Software Version 4.2.x or later.

- Step 13** Enter the port associated with the service to be accelerated.
- Step 14** Click **Add** to add each address. If you specify a server hostname, the Central Manager resolves the hostname to the IP address and adds it to the Server IP/Ports table.
- Step 15** To remove an IP address from the list, click **Delete**.
- Step 16** Choose a certificate and key pair method (Figure 12-27).

Figure 12-27 Configuring Service Certificate and Private Key

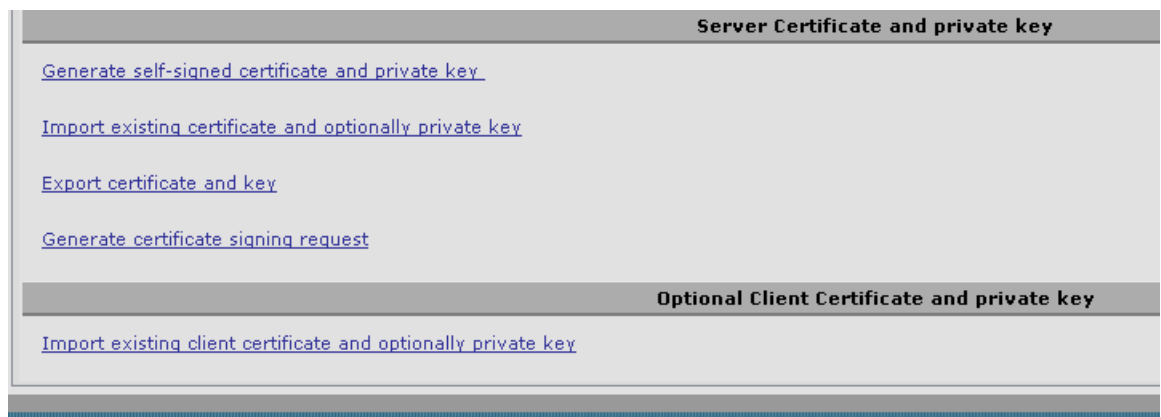

- Click **Generate Self-signed Certificate Key** to have the WAAS devices use a self-signed certificate/key pair for SSL.
- Click **Import Existing Certificate Key** to upload or paste an existing certificate/key pair.



Note In case of SaaS applications, the certificate should have the Subject Alternative Name (SAN) information.

- Click **Export Certificate Key** to export the current certificate/key pair.
- Click **Generate Certificate Signing Request** to renew or replace the existing certificate/key pair. The certificate signing request is used by the CA to generate a new certificate. The file that you import or export must be in either PKCS12 format or PEM format.
- Click **Import existing client certificate and optionally private key** to use the client configured certificate.

For service certificate and private key configuration steps, see [Configuring a Service Certificate and Private Key](#).

**Note**

If you change the certificate or key for an existing SSL-accelerated service, you must uncheck the **In service** check box and click **Submit** to disable the service, and then wait 5 minutes and check the **In service** check box and click **Submit** to re-enable the service. Alternatively, in the WAE, you can use the **no inservice** SSL-accelerated service configuration command, wait a few seconds, and then use the **inservice** command. If you are changing the certificate or key for multiple SSL-accelerated services, you can restart all the accelerated services by disabling and then re-enabling the SSL accelerator.

- Step 17** Click the **Advanced Settings** tab to configure SSL parameters for the service.
The Advanced SSL Accelerated Services Configuration window appears (Figure 12-28).

Figure 12-28 SSL Accelerated Services—Advanced Window

<input type="checkbox"/>	Priority	Cipher
<input type="checkbox"/>	1	dhe-rsa-with-aes-256-cbc-sha
<input type="checkbox"/>	1	rsa-with-aes-256-cbc-sha
<input type="checkbox"/>	1	dhe-rsa-with-aes-128-cbc-sha
<input type="checkbox"/>	1	rsa-with-aes-128-cbc-sha
<input type="checkbox"/>	1	dhe-rsa-with-3des-ede-cbc-sha
<input type="checkbox"/>	1	rsa-with-3des-ede-cbc-sha
<input type="checkbox"/>	-	...

- Step 18** (Optional) From the SSL version drop-down list, choose the type of SSL protocol to use, or choose **Inherited** to use the SSL protocol configured in global SSL settings. Choose **SSL3** for the SSL Version 3 protocol, **TLS1** for the Transport Layer Security Version 1 protocol, or **All** to use both SSL3 and TLS1 SSL protocols.
- Step 19** (Optional) From the Cipher List drop-down list, choose a list of cipher suites to be used for SSL acceleration between the WAE device peers, or choose **Inherited** to use the cipher list configured in SSL global settings. For more information, see [Working with Cipher Lists](#).
- Step 20** (Optional) To set the OCSP parameters for certificate revocation, follow these steps:
- To enable the verification of client certificate check, check the **Verify client certificate** check box.

- b. Check the **Disable revocation check for this service** check box to disable OCSP client certificate revocation checking.
- c. To enable verification of server certificate check, check the **Verify server certificate** check box.
- d. Check the **Disable revocation check for this service** check box to disable OCSP server certificate revocation checking.



Note If the server and client devices are using self-signed certificates and certificate verification is enabled, WAAS devices will not be able to accelerate SSL traffic.

Step 21 Click **Submit** after you have finished configuring the SSL accelerated service.

Updating a Certificate/Key in a SSL Accelerated Service

If at some point you need to update a certificate or key in a SSL Accelerated Service, follow these steps:

- Step 1** From the WAAS Central Manager menu, choose **Devices** > *device-name* (or **Device Groups** > *device-group-name*).
- Step 2** Choose **Configure** > **Acceleration** > **SSL Accelerated Services**.
- Step 3** Click **Edit SSL Accelerated Service** button in the **Name** column for the service in question.
- Step 4** Choose a certificate and key pair method (Figure 12-27) to either re-generate a self-signed certificate and private key or to import an updated certificate and/or key.
- Step 5** Depending on the chosen method fill out the required details, then click **Generate** or **Import** and next click **Submit**.



Note When you update a certificate for a SSL Accelerated Service and want it to be used by it, it is important to stop and start the configured SSL Accelerated Service. This step is required because the existing certificate and key are stored in memory on the accelerators. Updating the certificate/key via the steps described above is insufficient because it does not update the certificate/key in memory.
To ensure the updated certificate for the SSL Accelerated Service is used, make sure to follow the steps below as well.

- Step 6** Click the **Edit SSL Accelerated Service** button in the **Name** column for the service in question.
- Step 7** Remove the check mark for **In service**, then click **Submit**.
- Step 8** Click the **Edit SSL Accelerated Service** button in the **Name** column for the service in question for one last time.
- Step 9** Enable the check mark for **In service** then click **Submit**.

Configuring SSL Acceleration for SaaS Applications

SaaS applications are typically served from multiple SSL server farms, with multiple hosts spanning several data centers. For SSL services hosted in the enterprise data center, the IT administrator knows and controls the SSL server IP and can provide it to the data center WAAS. But for a SSL service that is hosted at a third-party SaaS provider in the cloud, the SSL server IP address is not controlled by the IT administrator because the cloud provider uses multiple Content Delivery Networks (CDNs) and data centers. Even for a single SaaS service, there might be multiple server IP addresses that can change dynamically. This leads to inadvertent errors due to namespace/certificate mismatch for SaaS applications.

To avoid these errors and to ensure that these applications are optimized, follow these steps to configure the SSL-accelerated services for SaaS applications:

Step 1 Create an SSL-accelerated service for a SaaS application using Step 1 through Step 8 outlined in [Using SSL Accelerated Services](#).

Step 2 To match subject alternative names, check the **Match Server Name Indication** check box. Alternately, use the **match sni** command on the core WAAS device.

If enabled, the SSL accelerator parses the initial SSL connection setup message for the destination hostname (in the SSL protocol extension called Server Name Indication) and uses that to match it with the Subject Alternate Names list in the SSL certificate on the WAAS device.



Note We recommend this setting for optimizing cloud-based SaaS applications to avoid namespace/certificate mismatch errors that are caused due to the changing nature of the SaaS server domains and IP addresses.



Note Most modern browsers provide Server Name Indication (SNI) support. Ensure that you use a browser that supports SNI.



Note The Match Server Name Indication option is available only on devices running WAAS 5.3.5 or later.

Step 3 Use the keyword **Any** to specify the server IP address of the accelerated server.

Step 4 Direct all SSL traffic for SAAS applications to port 443.
The above configuration overrides any wildcard configuration.



Note If you have configured port 443 for traffic other than SaaS applications, you should review and reconfigure it appropriately.

Step 5 Click **Import Existing Certificate Key** to upload or paste a certificate/key pair. The certificate should be specifically used for the SaaS-accelerated service and should contain the Subject Alternate Names for the server domains that need to be optimized. Identify the server domains that need to be added for optimizing SaaS applications, by following the steps outlined in [Determining Server Domains Used by SaaS Applications](#).

**Note**

You must create a new certificate with the missing server domain names derived from the list at regular intervals to ensure that the connections are optimized.

Step 6 Click **Submit** to complete configuring the SSL-accelerated service for the SaaS application.

Determining Server Domains Used by SaaS Applications

When you check the **Match Server Name Indication** check box, you can log in to the core WAAS device and use the **sh crypto ssl services accelerated-service service-name** command to view the list of server domain names that do not match the existing SSL certificate and hence are not optimized. If you want to optimize any of these server domain names, select and add them to your certificate by performing the following steps below.

The server domain names list contains a maximum of 128 server names.

- Step 1** Identify the relevant servers to be added. Use the **sh crypto ssl services accelerated-service service-name** to see additional details regarding the count and last seen information of the server name. If you need additional information to view the IP address and hostnames, use the **debug accelerator ssl sni** command to enable SNI debugs.
- Step 2** Log in to the Microsoft Management Console(MMC), OpenSSL, or any other available customer tool to create a new Certificate Signing Request (CSR) with the relevant server domain names of the SaaS applications in the subject alternative names extension of the certificate. Refer to the highlighted area in the example certificate below.

**Note**

When you add the SAN to the certificate, domain names should be separated by a comma. Note that a list of hostnames on a domain can be secured with a single certificate. For example, a.b.c.com and c.b.com can be added as *.b.c.com. However, for a new hostname on another domain, you have to make a new entry. For example, for b.c.com you have to add it as b.c.com or *.c.com. Additionally, you can also secure hostnames on different base domains in the same certificate, for example a.b.com and a.b.net.

Certificate:

```
Data:
  Version: 3 (0x2)
  Serial Number:
    ec:aa:9b:10:fa:9d:09:95
  Signature Algorithm: sha1WithRSAEncryption
  Issuer: C=US, ST=California, L=San Jose, O=Cisco
  Systems Inc, OU=WAAS,
  CN=Cisco_WAAS_CA/emailAddress=support@cisco.com
  Validity
    Not Before: Jul 31 06:49:56 2013 GMT
    Not After : Aug 30 06:49:56 2013 GMT
  Subject: C=US, ST=California, L=San Jose, O=Cisco
  Systems Inc, OU=WAAS,
  CN=Office365/emailAddress=support@cisco.com
  Subject Public Key Info:
    Public Key Algorithm: rsaEncryption
    Public-Key: (1024 bit)
    Modulus:
      00:c6:85:0d:f9:df:4e:4f:c4:53:d5:3e:0f:c4:cb:
      53:42:34:34:7d:92:7f:ea:c1:75:0b:21:3f:5f:a1:
      be:34:f1:40:c3:32:52:a1:05:79:26:7b:a3:29:c5:
```

```

5e:9f:3f:92:6b:d1:b2:fd:bc:c9:2b:8b:e2:9f:1a:
91:83:9b:c8:7f:3f:d9:56:92:75:be:b6:ed:39:39:
2f:1a:2f:ba:39:1b:06:76:0a:17:b5:f0:ec:dd:4c:
fa:94:be:ea:7c:e0:4e:51:b4:d2:75:4d:8b:d9:6e:
de:34:10:c7:c5:e8:97:5f:f2:7f:97:1e:9a:e0:e2:
fc:b4:58:11:45:82:19:14:11
Exponent: 65537 (0x10001)
X509v3 extensions:
  X509v3 Basic Constraints:
    CA:FALSE
  X509v3 Key Usage:
    Digital Signature, Non Repudiation, Key Encipherment
  X509v3 Subject Alternative Name:
    DNS:*.office365.com, DNS:outlook.com, DNS:*.aadcdn.microsoftonline-p.com,
DNS:*.aspnetcdn.com, DNS:*.client.hip.live.com, DNS:*.hip.live.com,
DNS:*.linkedinlabs.com, DNS:*.live.com, DNS:*.microsoft.com, DNS:*.microsoftonline-p.com,
DNS:*.microsoftonline-p.net, DNS:*.microsoftonline.com, DNS:*.microsoftonlineimages.com,
DNS:*.microsoftonlinesupport.net, DNS:*.msecnd.net, DNS:*.msocdn.com, DNS:*.office.net,
DNS:*.office365.com, DNS:*.officeapps.live.com, DNS:*.officecdn.microsoft.com,
DNS:*.onmicrosoft.com, DNS:*.outlook.com, DNS:*.res.outlook.com, DNS:*.sharepoint.com,
DNS:*.sharepointonline.com, DNS:*.telemetry.microsoft.com,
DNS:*.testexchangeconnectivity.com, DNS:*.vo.msecnd.net, DNS:*.webtrends.com

Signature Algorithm: sha1WithRSAEncryption
46:db:34:7f:c0:8e:13:81:67:0b:3c:8d:15:3a:ee:1f:c7:cf:
d1:6b:de:00:2a:35:9b:13:d6:bf:79:43:ce:31:c6:f9:de:f7:
20:1f:0e:86:9e:d4:91:01:57:a2:7b:fe:91:00:de:cf:58:90:
85:97:49:b3:11:4c:e9:05:d0:a1:a7:73:7e:50:64:8f:80:f4:
ec:fa:a7:bb:7a:c2:df:5e:c5:e3:a8:52:c4:31:4e:8e:53:36:
59:e9:0f:27:82:71:4e:3b:79:a4:c9:4f:18:7e:06:7a:0c:34:
0a:cf:3c:3e:73:73:5a:52:7d:03:a0:75:50:5a:d4:a5:8b:a9:
ea:96

```

Step 3 Submit the certificate to the Enterprise CA.

Step 4 Import the signed certificate from the Enterprise CA to the Trusted Root Certification Authorities store.\



Note The Enterprise root CA should be present in browser as trusted root CA.

Step 5 Uncheck the **In service** checkbox and click **Submit** to disable the accelerated service.

Step 6 Upload the new certificate and re-enable the service.

Configuring SMART-SSL Accelerator

SMART-SSL is an encryption service that enables L7 application network services (e.g. ftp, http, dns) to optimize traffic on SSL/TLS encrypted applications. It enables content caching for SSL/TLS applications (http object cache for https traffic) in single sided deployment.

With the evolution of cloud services, there is a critical need to provide application optimization in a single sided mode. Starting with release 6.2.1, SMART-SSL optimization, is enabled using single-sided mode. In a single-sided deployment, the interposing device does not require a peer device to process the SMART-SSL traffic flow. SMART-SSL traffic flows directly to the edge device without having to go through the core device.

However, to ensure this optimization, you need to enable the SMART-SSL (SSL Accelerator v2) accelerator.

The table below provides an overview of the steps you must complete to set up and enable SMART-SSL acceleration.

Table 12-4 Checklist for Configuring SSL v2 Acceleration

Task	Additional Information and Instructions
1. Prepare to configure SMART-SSL acceleration.	Identifies the information that you need to gather before configuring SMART-SSL acceleration on your WAAS devices. For more information, see Preparing to use SMART-SSL acceleration .
2. Set up to use existing Enterprise Root CA certificates	(Optional) Describes how to create, import, and manage existing Enterprise Root certificate authority (CA) certificates. For more information, see Using existing Root CA to sign WAAS accelerated service exported certificate .
3. Enable SMART-SSL application optimization.	Describes how to activate the SMART-SSL acceleration feature. For more information, see Enabling and Disabling the Global Optimization Features .
4. Set up accelerated service certificates.	Describes how to create, import, and use certificates for SMART-SSL acceleration. For more information, see Creating Single-Sided SMART-SSL Accelerated Service Certificate .
5. Configure and enable SSL-accelerated services.	Describes how to add, configure, and enable services to be accelerated by the SMART-SSL application optimization feature. For more information, see Configuring and enabling SMART-SSL accelerated services on single-sided device group .

Preparing to use SMART-SSL acceleration

Before you configure SMART-SSL acceleration, you should know the following information:

- The services that you want to be accelerated on the SMART-SSL traffic. You will need to create a certificate to optimize these services using their urls or domain names, for e.g. www.google.com, *.google.com.
- The server IP address and port information. Optionally if the url or domain cannot be used, you can choose to specify a server ip. If you have specified a url, you can still specify a port. In case you have specified a URL you can still specify a port.
- The public key infrastructure (PKI) certificate and private key information, including the certificate common name and CA-signing information.
- The SSL versions supported.
SSLv3, TLS1.0, TLS1.1, TLS1.2 are supported with this release.

- Supported ciphers

The following lists the twenty seven supported ciphers:

```
TLS_RSA_WITH_3DES_EDE_CBC_SHA, /* 0x000A */
TLS_DHE_RSA_WITH_3DES_EDE_CBC_SHA, /* 0x0016 */
TLS_RSA_WITH_AES_128_CBC_SHA, /* 0x002F */
TLS_DHE_RSA_WITH_AES_128_CBC_SHA, /* 0x0033 */
TLS_RSA_WITH_AES_256_CBC_SHA, /* 0x002F */
TLS_DHE_RSA_WITH_AES_256_CBC_SHA, /* 0x0039 */
TLS_RSA_WITH_AES_128_CBC_SHA256, /* 0x003C */
TLS_RSA_WITH_AES_256_CBC_SHA256, /* 0x003D */
TLS_RSA_WITH_CAMELLIA_128_CBC_SHA, /* 0x0041 */
TLS_DHE_RSA_WITH_CAMELLIA_128_CBC_SHA, /* 0x0045 */
TLS_DHE_RSA_WITH_AES_128_CBC_SHA256, /* 0x0067 */
```

```

TLS_DHE_RSA_WITH_AES_256_CBC_SHA256, /* 0x006B */
TLS_RSA_WITH_CAMELLIA_256_CBC_SHA, /* 0x0084 */
TLS_DHE_RSA_WITH_CAMELLIA_256_CBC_SHA, /* 0x0088 */
TLS_RSA_WITH_SEED_CBC_SHA, /* 0x0096 */
TLS_DHE_RSA_WITH_SEED_CBC_SHA, /* 0x009A */
TLS_RSA_WITH_AES_128_GCM_SHA256, /* 0x009C */
TLS_RSA_WITH_AES_256_GCM_SHA384, /* 0x009D */
TLS_DHE_RSA_WITH_AES_128_GCM_SHA256, /* 0x009E */
TLS_DHE_RSA_WITH_AES_256_GCM_SHA384, /* 0x009F */
TLS_ECDHE_RSA_WITH_3DES_EDE_CBC_SHA, /* 0xC012 */
TLS_ECDHE_RSA_WITH_AES_128_CBC_SHA, /* 0xC013 */
TLS_ECDHE_RSA_WITH_AES_256_CBC_SHA, /* 0xC014 */
TLS_ECDHE_RSA_WITH_AES_128_CBC_SHA256, /* 0xC027 */
TLS_ECDHE_RSA_WITH_AES_256_CBC_SHA384, /* 0xC028 */
TLS_ECDHE_RSA_WITH_AES_128_GCM_SHA256, /* 0xC02F */
TLS_ECDHE_RSA_WITH_AES_256_GCM_SHA384 /* 0xC030 */

```

- SSL compression is not supported.

Using existing Root CA to sign WAAS accelerated service exported certificate

A root SSL certificate is a certificate issued by a trusted certificate authority and is in turn trusted by domain clients. This is used to sign all the certificated that are to be used by WAAS for SSL interposing during client and server SSL handshake for optimizing the applications or the URLs. This CA needs to be capable of accepting certificate signing requests (CSRs) that include subject alternative names and generate certificates that include subject alternative names. The subject alternative name is an extension to the X.509 protocol that allows various values to be associated with a security certificate (SSL certificate). Subject alternative names can include IP addresses, email addresses, universal resource identifiers (URIs), alternative common Domain Name System (DNS) names, alternatives to the distinguished name, and other information. You can install this on all machines that will be communicating with services using SSL certificates generated by this root certificate.

-
- Step 1** If your organization already has a well known root CA, you can use it. You can also import a new CA using the WAAS Central Manager GUI. For more information, see [Working with Certificate Authorities](#).

Alternately, if you need to create a new CA, use a Linux machine with openssl version of 1.0.1e or greater to create these certificates. Create the root CA key. This signs all issued certificates.

```
openssl genrsa -out rootCA.key.pem 2048
```

- Step 2** Create the self-signed root CA certificate, with the key generated above.

```
openssl req -x509 -new -nodes -key rootCA.key -days 365 -out rootCA.crt
```

- Step 3** Verify the root certificate.

- Step 4** Import the certificate from the Enterprise CA to the Trusted Root Certification Authorities store on the client browser and install the root CA certificate and intermediate CA certificate.

Creating Single-Sided SMART-SSL Accelerated Service Certificate

To create the certificate to be used with the accelerated service, follow the steps below:

-
- Step 1** Create a new encryption key pair using open ssl.

- Step 2** Create a Certificate Signing Request (CSR) and key pair and other needed attributes such as Common Name, Company and SubjAltName for the application you are trying to optimize. For example, in case of youtube, make sure the subjectAltNames have all the URLs that YouTube servers include in their certificate that you would like to optimize.

```
openssl req -new -key server.key -out server.csr
```

```
X509v3 extensions:
```

```
    X509v3 Basic Constraints:
```

```
        CA:FALSE
```

```
    Netscape Comment:
```

```
        NGSSL Demo Certificate
```

```
    X509v3 Subject Key Identifier:
```

```
        65:C1:42:98:47:81:0E:04:7A:7D:83:A7:43:C9:A3:B8:1F:DB:BF:1E
```

```
    X509v3 Authority Key Identifier:
```

```
        keyid:8C:F6:0A:BC:E4:EB:2C:D9:6B:68:95:09:1B:B5:82:66:CE:ED:6B:77
```

```
    X509v3 Subject Alternative Name:
```

```
DNS:*.google.com, DNS:*.android.com, DNS:*.appengine.google.com, DNS:*.cloud.google.com,
DNS:*.google-analytics.com, DNS:*.google.ca, DNS:*.google.cl, DNS:*.google.co.in,
DNS:*.google.co.jp, DNS:*.google.co.uk, DNS:*.google.com.ar, DNS:*.google.com.au,
DNS:*.google.com.br, DNS:*.google.com.co, DNS:*.google.com.mx, DNS:*.google.com.tr,
DNS:*.google.com.vn, DNS:*.google.de, DNS:*.google.es, DNS:*.google.fr, DNS:*.google.hu,
DNS:*.google.it, DNS:*.google.nl, DNS:*.google.pl, DNS:*.google.pt,
DNS:*.googleadapis.com, DNS:*.googleapis.cn, DNS:*.googlecommerce.com,
DNS:*.googlevideo.com, DNS:*.gstatic.cn, DNS:*.gstatic.com, DNS:*.gvt1.com,
DNS:*.gvt2.com, DNS:*.metric.gstatic.com, DNS:*.urchin.com, DNS:*.url.google.com,
DNS:*.youtube-nocookie.com, DNS:*.youtube.com, DNS:*.youtubeeducation.com,
DNS:*.yting.com, DNS:android.clients.google.com, DNS:android.com, DNS:g.co, DNS:goo.gl,
DNS:google-analytics.com, DNS:google.com, DNS:googlecommerce.com, DNS:urchin.com,
DNS:www.goo.gl, DNS:youtu.be, DNS:youtube.com, DNS:youtubeeducation.com
```

Alternately, if you want to create a CSR from the CM GUI, you can follow the steps in [Configuring a Service Certificate and Private Key](#).

- Step 3** Create new proxy server certificate by signing the above generated CSR with your existing Enterprise Root CA, or the one created above. This will generate .crt or .pem certificate file. Note that the CA certificate used to sign this accelerated service certificate should be present in the client browser root CA store for the accelerated service proxy certificate created to be authenticated and accepted by the client browser.

- IE or Chrome: settings- advanced settings - certificates - import - add the root ca -into trusted root authorities. Clear the browser cache and reload the browser for the cloud application and it should pick up the new certificate.
- Mozilla: options - advanced - Certificates> View certificates > Import - click all the three for the trusted zones and import the certificate. Clear the browser cache and reload the browser for the cloud application and it should pick up the new certificate.

- Step 4** WAAS allows importing certificates with pkcs12 format. To generate the pkcs12 format from the certificate file and your private key use the open ssl command.

```
openssl pkcs12 -export -out server.p12 -inkey proxyserver.key -in proxyserver.crt
-certfile CACert.crt
```

- Step 5** Import this certificate into the WAAS device group using **crypto import EXEC** command and thereafter be used in the accelerated server configuration as server-cert-key.

```
WAE#crypto import pkcs12 newcert.p12 pkcs12{disk| ftp | http | sftp | tftp}
for e.g.
WAE#crypto import pkcs12 youtube.p12 pkcs12 disk youtube_newcert.p12
```

- Step 6** It is important to note that the CA cert used to sign this ASVC cert will need to exist in the browser rootCA store for the accelerated service proxy certificate create to be authenticated and accepted by the browser.



Note The WAAS CM CA repository does not include the 'CN=GTE CyberTrust Global Root' certificate. You will need to manually import and configure it from the Central Manager or the device to use it to validate o365 certificates.

Configuring and enabling SMART-SSL accelerated services on single-sided device group

The following are prerequisites for using Cisco WAAS to optimize SMART-SSL traffic:

- The Central Manager and WAE's must be running software version 6.2.x.
- A new device group that will support single-sided acceleration. To create a device group, see [Creating a Device Group](#) in Chapter 3, "Using Device Groups and Device Locations."

After you have created an accelerated service certificate for WAN optimization, to enable the SMART-SSL settings on this group follow these steps:

-
- Step 1** From the WAAS Central Manager menu, choose **Device Groups** > *device-group-name*, to select the device group created above. Add only branch devices to this group. These devices will optimize the SSL traffic as it passes through them.
- Step 2** Choose **Configure** > **Acceleration** > **Enabled Features**.
- Step 3** Check the **SSL Interposer (SSL Accelerator V2)** check box to enable SMART-SSL acceleration.
- Step 4** Create an SSL accelerated service for the device group. Choose **Acceleration** > **SSL Accelerated Services** and click the **Create** button. The **Creating new SSL Accelerated Service** page opens.
- Step 5** In the SSL Accelerated Service section, name your service, and select **In service** box. You can also provide a short description.
- Step 6** In the Server Addresses section, enter "any" in the **IP Address** box and "443" in the **Server Port** box. Then click **Add**.
- Step 7** In the **Certificate and Private Key** section, click **Import Existing Certificate and Optionally Private Key** and select **Upload File in PKCS#12 Format**. Supply the password used to export the certificate (Using the **Browse** button, locate the certificate. Then click the **Import** button. A confirmation screen with the certificate information appears.
- Step 8** Click **Submit** to complete configuring the SSL-accelerated service to use single sided optimization. Alternatively, if you want to automate the entire process using a script, we recommend that you get in touch with the Cisco Technical Assistance Center (TAC).
- Step 9** Monitor the SMART-SSL accelerated service optimization statistics using the Cisco WAAS Central Manager and the command-line interface (CLI) using the **show statistics encryption-services** exec command.
-

Alternately, to enable SMART-SSL acceleration from the CLI, use the **(config) crypto encryption-service enable** global configuration command.

The SSL accelerator and the SMART-SSL accelerator use the same configuration commands. However, for the SMART-SSL configuration, only a limited set of keywords are supported. The following table elaborates the supported keywords.

Supported Attributes	Not-supported Attributes
client-cert-key	cipher-list - to configure ciphers
client-cert-verify	client-version-rollback
description – annotation info	match
inservice	protocol-chaining
server-cert-key	version - to configure SSL version
server-cert-verify	
server-domain + port	
configure IP + port	

office365 optimization using Azure vWAAS

Microsoft Office365 supports various business critical applications like email, office online, skype for business etc. Office365 as SaaS has become very popular in the past few years. As enterprises are moving towards SaaS applications like office365; performance and user experience of these applications become more and more critical.

WAAS support for Office365 traffic acceleration and optimization was introduced in release 5.3.5, but it was limited to optimization between the on-premise data center to the customer branch. The traffic between the customer data center to office365 was not optimized.

With release 6.2.1, traffic to office365 can be optimized till it reaches the cloud by implementing a solution that comprises of the following:

- Enabling WAAS as SaaS over Azure.
- Positioning WAAS as SaaS near to Office365 service by configuration.
- Routing and DNAT using CSR in Azure.
- Using IWAN as transport.
- Detecting Office365 traffic using SS accelerator.

Prerequisites

Before you create an o365 accelerated service on the WAAS Central Manger, you must have completed the following:

- Deployed Virtual Network in Azure
- Deployed CSR 1000v for secure network extension and DNAT
- Deployed Azure vWAAS
- Configured Azure Route tables
- Configured Azure CSR
- Registered the Azure vWAAS device with the WAAS Central Manager.

The table below provides an overview of the steps you must complete to set up and enable o365 acceleration from the WAAS Central Manager.

Table 12-5 Checklist for Configuring o365 Acceleration

Task	Additional Information and Instructions
1. Prepare for configuring SSL acceleration.	Identifies the information that you need to gather before configuring SSL acceleration on your WAAS devices. For more information, see Prerequisites for Configuring SSL Acceleration .
2. Set up Root CA certificates	(Optional) Describes how to create, import, and manage certificate authority (CA) certificates. For more information, see Create a Root CA certificate .
3. Enable SSL application optimization.	Describes how to activate the SSL acceleration feature. For more information, see Enabling and Disabling the Global Optimization Features .
4. Set up accelerated service certificates.	Describes how to create, import, and use certificates for o365 acceleration. For more information, see Creating o365 Accelerated Service Certificate .
5. Configure and enable o365 accelerated services.	Describes how to add, configure, and enable o365 accelerated service through the WAAS Central Manager. For more information, see Configuration for o365 acceleration from the WAAS Central Manager .

Create a Root CA certificate

A root SSL certificate is a certificate issued by a trusted certificate authority and is in turn trusted by domain clients. This is used to sign all issued certificates. This CA needs to be capable of accepting certificate signing requests (CSRs) that include subject alternative names and generate certificates that include subject alternative names. The subject alternative name is an extension to the X.509 protocol that allows various values to be associated with a security certificate (SSL certificate). Subject alternative names can include IP addresses, email addresses, universal resource identifiers (URIs), alternative common Domain Name System (DNS) names, alternatives to the distinguished name, and other information. You can install this on all machines that will be communicating with services using SSL certificates generated by this root certificate. If your organization already has a root CA for its internal use, you can use it instead of a new root CA. If not, use a Linux machine with openssl version of 1.0.1e or greater to create these certificates.

-
- Step 1** Create the root CA key. This signs all issued certificates.
 - Step 2** Create the self-signed root CA certificate, with the key generated above.
 - Step 3** Verify the root certificate.

Import the certificate from the Enterprise CA to the Trusted Root Certification Authorities store on the client browser and install the root CA certificate and intermediate CA certificate.

Creating o365 Accelerated Service Certificate

To create the certificate to be used with the accelerated service, follow the steps below:

-
- Step 1** Log in to the Microsoft Management Console (MMC), OpenSSL, or any other available customer tool to create a new Certificate Signing Request (CSR) with the relevant server domain names of the o365 application in the subject alternative names extension of the certificate. Refer to the highlighted area in the example certificate below.

```
Certificate:
  Data:
    Version: 3 (0x2)
    Serial Number:
      ec:aa:9b:10:fa:9d:09:95
```

```

Signature Algorithm: sha1WithRSAEncryption
Issuer: C=US, ST=California, L=San Jose, O=Cisco
Systems Inc, OU=WAAS,
CN=Cisco_WAAS_CA/emailAddress=support@cisco.com
Validity
    Not Before: Jul 31 06:49:56 2013 GMT
    Not After : Aug 30 06:49:56 2013 GMT
Subject: C=US, ST=California, L=San Jose, O=Cisco
Systems Inc, OU=WAAS,
CN=Office365/emailAddress=support@cisco.com
Subject Public Key Info:
    Public Key Algorithm: rsaEncryption
    Public-Key: (1024 bit)
    Modulus:
        00:c6:85:0d:f9:df:4e:4f:c4:53:d5:3e:0f:c4:cb:
        53:42:34:34:7d:92:7f:ea:c1:75:0b:21:3f:5f:a1:
        be:34:f1:40:c3:32:52:a1:05:79:26:7b:a3:29:c5:
        5e:9f:3f:92:6b:d1:b2:fd:bc:c9:2b:8b:e2:9f:1a:
        91:83:9b:c8:7f:3f:d9:56:92:75:be:b6:ed:39:39:
        2f:1a:2f:ba:39:1b:06:76:0a:17:b5:f0:ec:dd:4c:
        fa:94:be:ea:7c:e0:4e:51:b4:d2:75:4d:8b:d9:6e:
        de:34:10:c7:c5:e8:97:5f:f2:7f:97:1e:9a:e0:e2:
        fc:b4:58:11:45:82:19:14:11
    Exponent: 65537 (0x10001)
    X509v3 extensions:
        X509v3 Basic Constraints:
            CA:FALSE
        X509v3 Key Usage:
            Digital Signature, Non Repudiation, Key Encipherment
        X509v3 Subject Alternative Name:
DNS.1 = *.virtualearth.net; DNS.2 = *.msocdn.com; DNS.3 = *.office365.com; DNS.4 =
*.outlook.com; DNS.5 = outlook.com; DNS.6 = *.microsoftonline.com; DNS.7 =
*.res.outlook.com; DNS.8 = *.googleapis.com; DNS.9 = *.google-analytics.com; DNS.10 =
*.google.com; DNS.11 = *.googleusercontent.com; DNS.12 = *.gstatic.com; DNS.13 =
*.microsoftonline-p.com; DNS.14 = *.aadcdn.microsoftonline-p.com; DNS.15 =
*.aspnetcdn.com; DNS.16 = *.client.hip.live.com; DNS.17 = *.hip.live.com; DNS.18 =
*.infra.lync.com; DNS.19 = *.linkedinlabs.com; DNS.20 = *.live.com; DNS.21 = *.lync.com;
DNS.22 = *.microsoft.com; DNS.23 = *.microsoftonline-p.net; DNS.24 =
*.microsoftonlineimages.com; DNS.25 = *.microsoftlinesupport.net; DNS.26 = *.msecnd.net;
DNS.27 = *.msocdn.com; DNS.28 = *.office.net; DNS.29 = *.office365.com; DNS.30 =
*.officeapps.live.com; DNS.31 = *.officecdn.microsoft.com; DNS.32 = *.online.lync.com
DNS.33 = *.onmicrosoft.com; DNS.34 = *.sharepoint.com; DNS.35 =
*.sharepointonline.com; DNS.36 = *.telemetry.microsoft.com; DNS.37 =
*.testexchangeconnectivity.com; DNS.38 = *.vo.msccnd.net; DNS.39 = *.webtrends.com; DNS.40
= *.office.com; DNS.41 = *.portal.office.com;

Signature Algorithm: sha1WithRSAEncryption
46:db:34:7f:c0:8e:13:81:67:0b:3c:8d:15:3a:ee:1f:c7:cf:
d1:6b:de:00:2a:35:9b:13:d6:bf:79:43:ce:31:c6:f9:de:f7:
20:1f:0e:86:9e:d4:91:01:57:a2:7b:fe:91:00:de:cf:58:90:
85:97:49:b3:11:4c:e9:05:d0:a1:a7:73:7e:50:64:8f:80:f4:
ec:fa:a7:bb:7a:c2:df:5e:c5:e3:a8:52:c4:31:4e:8e:53:36:
59:e9:0f:27:82:71:4e:3b:79:a4:c9:4f:18:7e:06:7a:0c:34:
0a:cf:3c:3e:73:73:5a:52:7d:03:a0:75:50:5a:d4:a5:8b:a9:

```

Step 2 Submit the certificate to the Enterprise CA.

Step 3 Import the signed certificate from the Enterprise CA to the Trusted Root Certification Authorities store.\



Note The Enterprise root CA should be present in browser as trusted root CA.

- Step 4** Ensure that the CA certificate used to sign this accelerated service certificate should be present in the client browser root CA store for the accelerated service proxy certificate created to be authenticated and accepted by the client browser.
- IE or Chrome: settings- advanced settings - certificates - import - add the root ca -into trusted root authorities. Clear the browser cache and reload the browser for the cloud application and it should pick up the new certificate.
 - Mozilla: options - advanced - Certificates> View certificates > Import - click all the three for the trusted zones and import the certificate. Clear the browser cache and reload the browser for the cloud application and it should pick up the new certificate.

Configuration for o365 acceleration from the WAAS Central Manager

-
- Step 1** Register your Azure vWAAS device with the WAAS Central Manager. If the Central Manager is in a different network add routes for reachability.
- Step 2** Create an o365 accelerated service for the device group. Choose **Acceleration > SSL Accelerated Services** and click the **Create** button. The **Creating New SSL Accelerated Service** page opens.
- Step 3** In the SSL Accelerated Service section, name your service “o365”, and select both **In Service** and **Match Server Name Indication** boxes. You can also provide a short description.
- Step 4** In the Server Addresses section, enter “any” in the **IP Address** box and “443” in the **Server Port** box. Then click **Add**.
- Step 5** In the **Certificate and Private Key** section, click **Import Existing Certificate and Optionally Private Key** and select **Upload File in PKCS#12 Format** to upload the multi-domain certificate created earlier. Supply the password used to export the certificate Using the **Browse** button, locate the certificate created earlier. Then click the **Import** button.
A confirmation screen with the certificate information appears.
- Step 6** Click **Submit** to complete configuring the o365 accelerated service.

Alternately, you could use the CLI to copy the o365 certificate (o365.pfx) to the data center WAE and import the certificate using the **crypto import pkcs12 Azure_o365.p12 pkcs12 disk office365.pfx EXEC** command. Instead of importing multi-domain certificate from device disk, you can use remote methods (such as ftp, http) to import the certificate from servers. You can also configure the application accelerated service in th WAE with the imported certificate using the **crypto ssl services accelerated-service Azure_o365 EXEC** command.

- Step 7** Monitor the accelerated service optimization statistics using the Cisco WAAS Central Manager and the command-line interface (CLI) using the **show statistics connections optimized EXEC** command
-

Cisco Support for Microsoft Windows Update

Cisco support for Microsoft Windows Update enables caching of objects used in Windows OS and application updates. Cisco support for Microsoft Windows Update is enabled by default, and enabled only for specific sites.

This section contains the following topics:

- [Benefits of Cisco Support for Microsoft Windows Update](#)
- [Viewing Statistics for Cisco Support for Microsoft Windows Update](#)

- [Cisco Support for Microsoft Windows Update and Akamai Cache Engine](#)

Benefits of Cisco Support for Microsoft Windows Update

The Microsoft OS and application updates are managed by update clients such as Microsoft Update. Microsoft Update downloads the updates via HTTP, often in combination with BITS (Background Intelligent Transfer Service) to help facilitate the downloads. Clients use HTTP range request to fetch updates.

The objects that comprise the updates, such as .cab files, are typically cacheable, so that HTTP object cache is a significant benefit for this process.

For example, for Windows 7 and 8 OS updates—via direct Internet or WSUS (Windows Server Update Services), versions 2012 and 2012R2—more than 98% of the update files, such as .cab, .exe, and .psf files, are served from cache on subsequent updates. Cisco support for Microsoft Windows Update reduces the volume of WAN offload bytes and reduces response time for subsequent Windows updates.

Viewing Statistics for Cisco Support for Microsoft Windows Update

There are two ways to view data generated by Cisco support for Microsoft Windows Update:

- The [Top Sites](#) report, described in Chapter 15, “Monitoring Your WAAS Network” provides information including WAN response time and WAN offload bytes.
- For WAAS Version 6.1.1x and later, the cache engine access log file has two additional fields for Microsoft Windows Update statistics:
 - rm-w (range miss, wait)—The main transaction, a cache miss, which waited for the sub-transaction to fetch the needed bytes.
 - rm-f (range miss, full)—The sub-transaction, a cache write of the entire document.

Example 1:

Example 1 contains two log lines, the main transaction and sub-transaction, when a range is requested on an object that is not in cache:

```
ws8-rt-kb2863725-x64_dd8522e527483cd69bf61d98ee849a2406b97172.psf - -
08/28/2015 12:22:29.663 (f1=27520) 300 13.164 0.000 446 - - 34912 172.25.30.4
```

```
191.234.4.50 2905 h - - rm-w 206 GET
http://fg.v4.download.windowsupdate.com/d/msdownload/update/software/secu/2013/07/windows8-rt-kb2863725-x64_dd8522e527483cd69bf61d98ee849a2406b97172.psf - -
```

```
08/28/2015 12:24:31.448 (f1=27520) 300 134.949 0.000 355 344 3591542 568 172.25.30.4
191.234.4.50 2f25 m-s - - rm-f 200 GET
http://fg.v4.download.windowsupdate.com/d/msdownload/update/software/secu/2013/07/windows8-rt-kb2863725-x64_dd8522e527483cd69bf61d98ee849a2406b97172.psf - -
```

Example 2:

Example 2 shows a cache hit when a range is requested on an object that is either completely in cache, or in the process of being downloaded. If it is in the process of being downloaded, then the main transaction has latched onto a sub-transaction like the one shown in Example 1.

```
08/28/2015 03:34:36.906 (f1=26032) 300 0.000 50.373 346 - - 13169 172.25.30.4
8.254.217.62 2905 h - - - 206 GET
http://fg.v4.download.windowsupdate.com/d/msdownload/update/software/secu/2013/07/windows8-rt-kb2863725-x64_dd8522e527483cd69bf61d98ee849a2406b97172.psf - -
```

Cisco Support for Microsoft Windows Update and Akamai Cache Engine

Cisco support for Microsoft Windows Update enables Akamai Cache Engine to support Windows Update caching in two ways:

- Download and cache full objects even when ranges within objects that not in cache are requested.
- Future range requests on the objects can be served out of cache.

There is a limit, set by OTT metadata during the Akamai Connect registration process, from the start of the object—the number of bytes or the percent of file length—where the download functionality is triggered. A request of a size above the set limit does not initiate a full object download, and the request is forwarded to the origin as is.



Caution

Cisco Support for Microsoft Windows update is enabled by default, and enabled only for specific sites. The enabled sites are updated via OTT metadata.

If you want to disable Cisco Support for Microsoft Windows Update, you must disable OTT caching. To do this, uncheck the **Over the Top Cache** check box. However, note that unchecking the **Over the Top Cache** check box disables *all* OTT functionality, both global and custom OTT configurations.

For more information on the Akamai Connect registration process, see [Activating the Akamai Connect License](#) in Chapter 13, “Configuring Cisco WAAS with Akamai Connect.”

Creating a New Traffic Optimization Policy

[Table 12-7](#) provides an overview of the steps that you must complete to create a new traffic optimization policy.

Table 12-6 Checklist for Creating a New Optimization Policy

Task	Additional Information and Instructions
1. Prepare for creating an optimization policy.	Provides the tasks you need to complete before creating a new optimization policy on your WAAS devices. For more information, see Preparing to Create an Optimization Policy .
2. Create an application definition.	Identifies general information about the application you want to optimize, such as the application name and whether the WAAS Central Manager collects statistics about this application. For more information, see Creating an Application Definition .
3. Create an optimization policy.	Determines the type of action your WAAS device or device group performs on specific application traffic. This step requires you to do the following: <ul style="list-style-type: none"> • Create application class maps that allow a WAAS device to identify specific types of traffic. For example, you can create a condition that matches all traffic going to a specific IP address. • Specify the type of action your WAAS device or device group performs on the defined traffic. For example, you can specify that WAAS should apply TFO and LZ compression to all traffic for a specific application. For more information, see Creating an Optimization Policy .

Preparing to Create an Optimization Policy

Before you create a new optimization policy, complete the following tasks:

- Review the list of optimization policies on your WAAS system and make sure that none of these policies already cover the type of traffic you want to define. To view a list of the predefined policies that come bundled with the WAAS system, see [Appendix A, “Predefined Optimization Policy.”](#)
- Identify a match condition for the new application traffic. For example, if the application uses a specific destination or source port, you can use that port number to create a match condition. You can also use a source or destination IP address for a match condition.
- Identify the device or device group that requires the new optimization policy. We recommend that you create optimization policies on device groups so that the policy is consistent across multiple WAAS devices.

Creating an Application Definition

The first step in creating an optimization policy is to set up an application definition that identifies general information about the application, such as the application name and whether you want the WAAS Central Manager to collect statistics about the application. You can create up to 255 application definitions on your WAAS system.

To create an application definition, follow these steps:

-
- Step 1** From the WAAS Central Manager menu, choose **Configure > Acceleration > Applications**.
- The Applications window appears, which displays a list of all the applications on your WAAS system. It also lists the device or device group from which it gets the settings.
- Step 2** From this window, perform the following tasks:
- Select an application and click the **Edit** icon in the task bar to modify the definition, or click the **Delete** icon in the task bar to delete.
 - Determine if your WAAS system is collecting statistics on an application. The Enable Statistics column displays Yes if statistics are being collected for the application.
 - Create a new application, as described in the steps that follow.
- Step 3** Click the **Add Application** icon in the taskbar.
- The Application window appears.
- Step 4** Enter a name for this application.
- The name cannot contain spaces and special characters.
- Step 5** (Optional) Enter a comment in the **Comments** field.
- The comment you enter appears in the Applications window.
- Step 6** Check the **Enable Statistics** check box to allow the WAAS Central Manager to collect data for this application. To disable data collection for this application, uncheck this check box.
- The WAAS Central Manager GUI can display statistics for up to 25 applications and 25 class maps. An error message is displayed if you try to enable more than 25 statistics for either. However, you can use the WAAS CLI to view statistics for all the applications that have policies on a specific WAAS device. For more information, refer to the [Cisco Wide Area Application Services Command Reference](#).

**Note**

If you are collecting statistics for an application, and decide to disable statistics collection, and then reenable statistics collection at a later time, the historical data is retained, but a gap in data will exist for the period when statistics collection was disabled. An application cannot be deleted if there is an optimization policy using it. However, if you delete an application that you had collected statistics for, and then later recreate the application, the historical data for the application is lost. Only data collected since the re-creation of the application is displayed.

**Note**

The WAAS Central Manager does not start collecting data for this application until you finish creating the entire optimization policy.

Step 7 Click **OK**.

The application definition is saved and is displayed in the application list.

Creating an Optimization Policy

After you create an application definition, create an optimization policy that determines the action a WAAS device takes on the specified traffic. For example, you can create an optimization policy that makes a WAAS device apply TCP optimization and compression to all application traffic that travels over a specific port or to a specific IP address. You can create up to 512 optimization policies on your WAAS system.

The traffic-matching rules are present in the application class map. These rules, known as match conditions, use Layer 2 and Layer 4 information in the TCP header to identify traffic.

To create an optimization policy, follow these steps:

Step 1 From the WAAS Central Manager menu, choose **Devices** > *device-name* (or **Device Groups** > *device-group-name*).

Step 2 Choose **Configure** > **Acceleration** > **Optimization Policies**.

The Optimization Policies window appears (Figure 12-29).

**Note**

In a WAAS Express device, the Optimization Policies window shows a subset of the fields in the standard Optimization Policies window.

Enable Service Policy option, DSCP option, and the Protocol column in the list of policy rules are not applicable to WAAS Express.

**Note**

When Cisco WAAS Express is used on the Cisco Integrated Services Router Generation 2 (ISR G2) with the Cisco VPN Internal Service Module (VPN-ISM) or with Group Encrypted Transport (GETVPN) enabled, the WAAS Express does not optimize FTP data.

To ensure that FTP data is optimized when WAAS Express is used with the Cisco ISR G2, use the ISR G2's IOS crypto map software.

Figure 12-29 Optimization Policies Window

Some configuration on this page may not have any effect on the WAE (individual or part of device group) until it is upgraded to version 5.x or above

Name: **WAAS-GLOBAL**

Description:

Enable Service Policy

DSCP:

Optimization Policy Rules for "WAAS-GLOBAL" Selected 0 | Total: 168

Position	Class-Map	Source IP	Destination IP	Source Ports	Destination P...	Protocol	Application	Action
<input type="checkbox"/>	1 MS-Exchange-Directory-RFR					ms-rfr	Email-and-Mes...	
<input type="checkbox"/>	2 MS-SQL-RPC					ms-sql	SQL	
<input type="checkbox"/>	3 MAPI					mapi	Email-and-Mes...	
<input type="checkbox"/>	4 MS-AD-Replication					ms-ad-rep	Replication	
<input type="checkbox"/>	5 MS-FRS					ms-frs	Replication	
<input type="checkbox"/>	6 MS-Exchange-Directory-NSPI					ms-exch-nspi	Email-and-Mes...	
<input type="checkbox"/>	7 AFS			7000 - 7009			File-System	
<input type="checkbox"/>	8 AOL			5190 - 5193			Instant-Messa...	

This window displays information about all the optimization policies that reside on the selected device or device group and the position of each policy. The position determines the order in which WAAS refers to that policy when determining how to handle application traffic. To change the position of a policy, see [Modifying the Position of an Optimization Policy](#). This window also displays the class map, source and destination IP addresses, source and destination ports, protocol, application, action, and accelerates assigned to each policy.



Note If there are WAAS Version 4.x devices, you can click the **Legacy View** taskbar icon to view the policies as they appear in a WAAS Version 4.x device.

From the Optimization Policies window, you can perform the following tasks:

- Configure a description, configure the Enable Service Policy setting, and configure the DSCP setting. This DSCP setting field configures DSCP settings at the device (or device group) level.



Note The device will only use this policy setting to determine what optimizations are performed if Enable Service Policy is set.

- Select one or more optimization policies that you want to delete, and click the **Delete** icon to delete the selected policies.
- Select an optimization policy and click the **Edit** icon to modify the checked policy.
- Restore predefined policies and class maps. For more information, see [Restoring Optimization Policies and Class Maps](#).
- Create an optimization policy, as described in the steps that follow.

Step 3 Click the **Add Policy Rule** icon in the taskbar to create a new optimization policy.

The Optimization Policy Rule pop-up window appears ([Figure 12-30](#)).

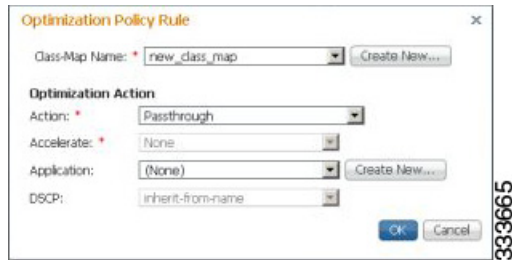
Figure 12-30 Add Optimization Policy Rule Window

- Step 4** From the Class-Map Name drop-down list, select an existing class map for this policy, or click **Create New** to create a new class map for this policy. For information on creating a new class map, see [Creating an Optimization Class Map](#).
- Step 5** From the Action drop-down list, choose the action that your WAAS device should take on the defined traffic. [Table 12-8](#) describes each action.



Note For a WAAS Express device, only a subset of actions are available: Passthrough, TFO Only, TFO with LZ, TFO with DRE, and TFO with DRE and LZ.

Table 12-7 Action Descriptions

Action ¹	Description
Passthrough	Prevents the WAAS device from optimizing the application traffic defined in this policy by using TFO, DRE, or compression. Traffic that matches this policy can still be accelerated if an accelerator is chosen from the Accelerate drop-down list.
TFO Only	Applies a variety of transport flow optimization (TFO) techniques to matching traffic. TFO techniques include BIC-TCP, window size maximization and scaling, and selective acknowledgement. For a more detailed description of the TFO feature, see Transport Flow Optimization in Chapter 1, “Introduction to WAAS.”
TFO with DRE (Adaptive Cache)	Applies both TFO and DRE with adaptive caching to matching traffic.
TFO with DRE (Unidirectional Cache)	Applies both TFO and DRE with unidirectional caching to matching traffic.
TFO with DRE (Bidirectional Cache)	Applies both TFO and DRE with bidirectional caching to matching traffic.
TFO with LZ Compression	Applies both TFO and the LZ compression algorithm to matching traffic. LZ compression functions similarly to DRE, but uses a different compression algorithm to compress smaller data streams and maintains a limited compression history.
TFO with DRE (Adaptive Cache) and LZ	Applies TFO, DRE with adaptive caching, and LZ compression to matching traffic.

Table 12-7 Action Descriptions (continued)

Action ¹	Description
TFO with DRE (Unidirectional Cache) and LZ	Applies TFO, DRE with unidirectional caching, and LZ compression to matching traffic.
TFO with DRE (Bidirectional Cache) and LZ	Applies TFO, DRE with bidirectional caching, and LZ compression to matching traffic.

1. When configuring a device running a WAAS version prior to 4.4.1, options that include Unidirectional or Adaptive caching are not shown in the Action list.



Note When ICA acceleration is enabled, all the connections are processed with the DRE mode as unidirectional, and acceleration type is shown as TIDL (TCP optimization, ICA acceleration, DRE, and LZ).



Note When configuring optimization policies on a device group, if the device group contains devices running a WAAS version prior to 4.4.1 and you are configuring an action that includes Unidirectional or Adaptive caching, the caching mode is converted to bidirectional. Similarly, when devices running a WAAS version prior to 4.4.1 join a device group that is configured with optimization policies that use Unidirectional or Adaptive caching, the caching mode is converted to bidirectional. In such cases, we recommend that you upgrade all the devices to the same software version or create different device groups for devices with incompatible versions.

Step 6 From the Accelerate drop-down list, choose one of the following additional acceleration actions that your WAAS device should take on the defined traffic:

- **None**—No additional acceleration is done.
- **MS PortMapper**—Accelerate using the Microsoft Endpoint Port Mapper (EPM).
- **SMB Adaptor**—Accelerate using the SMB Accelerators.
- **HTTP Adaptor**—Accelerate using the HTTP Accelerator.
- **MAPI Adaptor**—Accelerate using the MAPI Accelerator.
- **NFS Adaptor**—Accelerate using the NFS Accelerator.
- **ICA Adaptor**—Accelerate using the ICA Accelerator.



Note For a WAAS Express device, HTTP Express is available as an accelerator.

Step 7 Specify the application that you want to associate with this policy by performing either of the following:

- From the Application drop-down list, choose an existing application such as the one that you created, as described in [Creating an Application Definition](#). This list displays all the predefined and new applications on your WAAS system.
- Click **New Application** to create an application. You can specify the application name and enable statistics collection. After specifying the application details, click **OK** to save the new application and return to the Optimization Policy window. The new application is automatically assigned to this device or device group.

Step 8 (Optional) Choose a value from the DSCP Marking drop-down list. You can choose **copy**, which copies the DSCP value from the incoming packet and uses it for the outgoing packet. If you choose **inherit-from-name** from the drop-down list, the DSCP value defined at the application or global level is used.

DSCP is a field in an IP packet that enables different levels of service to be assigned to network traffic. Levels of service are assigned by marking each packet on the network with a DSCP code and associating a corresponding level of service. DSCP is the combination of IP Precedence and Type of Service (ToS) fields. For more information, see RFC 2474.

DSCP marking does not apply to pass-through traffic.



Note In a WAAS Express device, the DSCP Marking drop-down list is not shown.

For the DSCP marking value, you can choose to use the global default values (see [Defining Default DSCP Marking Values](#)) or select one of the other defined values. You can choose **copy**, which copies the DSCP value from the incoming packet and uses it for the outgoing packet.

Step 9 Click **OK**.

The new policy appears in the Optimization Policies window ([Figure 12-29](#)).

Creating an Optimization Class Map

You can create an optimization class map in two ways:

- In the device context, choose **Configure > Acceleration > Optimization Class-Map**, and then click the **Add Class-Map** taskbar icon.
- While adding or editing a policy rule, as described in [Creating an Optimization Policy](#), click **Create New** next to the Class-Map Name drop-down list.

The Optimization Class-Map pane is displayed for both of these methods.

To define an optimization class map for an optimization policy, follow these steps:

Step 1 Enter a name for this application class map. The name cannot contain spaces or special characters.



Note You must create a unique class map name across all types. For example, you cannot use the same name for an optimization class map and an AppNav class map.



Note In WAAS Express, the class map name cannot contain the following prefixes (case sensitive): class, optimize, passthrough, application, accelerate, tfo, dre, lz, or sequence-interval. Existing class map names containing any of these prefixes must be changed manually.

Step 2 (Optional) Enter a description.

Step 3 From the Type drop-down list, choose the class map type. Choose **Application Affinity** unless you want to match all the TCP traffic, in which case you should choose **Any TCP Traffic**.

Once you have chosen the type, you can enter the match conditions.

Step 4 Click the **Add Match Condition** icon to enter the conditions (Figure 12-31).



Note For a WAAS Express device, Protocol and EPM Custom UUID settings are not applicable.

Figure 12-31 Adding a New Match Condition Window

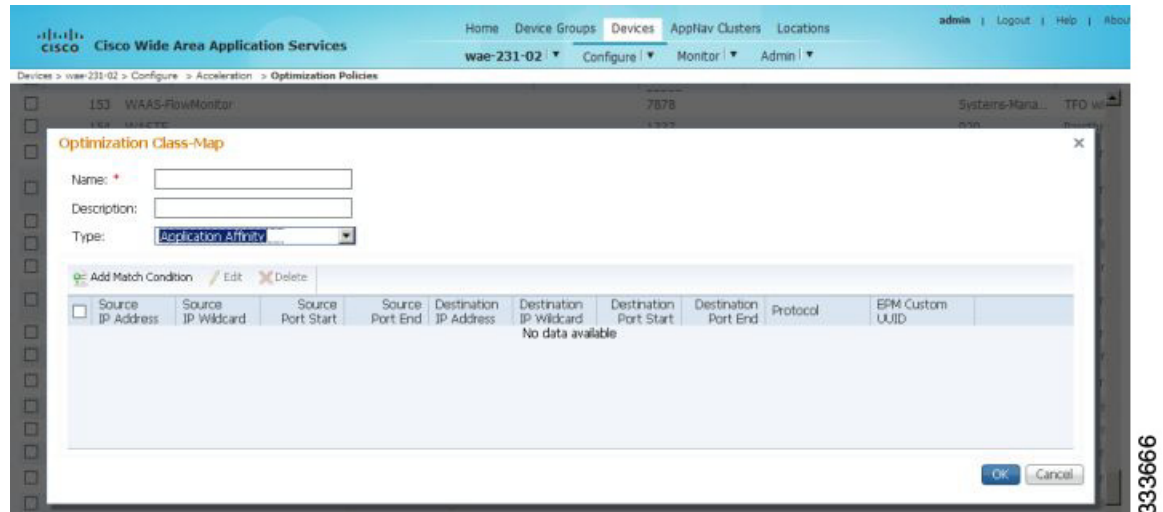

Step 5 Enter a value in one of the destination or source condition fields to create a condition for a specific type of traffic.

For example, to match all the traffic going to IP address 10.10.10.2, enter that IP address in the Destination IP Address field.



Note To specify a range of IP addresses, enter a wildcard subnet mask in either the destination or source IP Wildcard field in dotted decimal notation, such as 0.0.0.255 for /24.

To match traffic that uses dynamic port allocation, choose the corresponding application identifier from the Protocol drop-down list. For example, to match Microsoft Exchange Server traffic that uses the MAPI protocol, choose **mapi**. To enter a custom EPM UUID, choose **epm-uuid** and enter the UUID in the EPM Custom UUID field.



Note If you try to create a class map with an EMP UUID match condition that is already being used, that class map is removed and an error message is displayed stating that a class map already exists with the same EPM UUID match condition.

Step 6 Add additional match conditions, as needed. If any one of the conditions is matched, the class is considered as matched.

Step 7 Click **OK** to save the class map.

Managing Application Acceleration

This section contains the following topics:

- [Modifying the Accelerator Load Indicator and CPU Load-Monitoring Threshold](#)
- [Viewing a List of Applications](#)
- [Viewing a Policy Report](#)
- [Viewing a Class Map Report](#)
- [Restoring Optimization Policies and Class Maps](#)
- [Monitoring Applications and Class Maps](#)
- [Defining Default DSCP Marking Values](#)
- [Modifying the Position of an Optimization Policy](#)
- [Modifying the Acceleration TCP Settings](#)

Modifying the Accelerator Load Indicator and CPU Load-Monitoring Threshold

High CPU utilization can adversely affect current optimized connections. To avoid CPU overload, you can enable CPU load monitoring and set the load monitoring threshold. When the average CPU utilization on the device exceeds the set threshold for 2 minutes, the device stops accepting new connections and passes new connections, if any, through. When the average CPU utilization falls below the threshold for 2 minutes, the device resumes accepting optimized connections.

This section contains the procedures for modifying the accelerator load threshold and CPU load monitoring.



Note

When a CPU overload condition occurs, the polling interval is reduced to an interval of 2 seconds. Although the average CPU utilization may fall below the threshold during this time and the overload condition cleared, the CPU alarm may still be present. The CPU alarm is only cleared when the overload condition does not reappear in the next 2-minute-interval poll.

To modify the accelerator load indicator threshold and cpu load monitoring for a WAE device, follow these steps:

- Step 1** From the WAAS Central Manager menu, choose **Devices** > *device-name* (or **Device Groups** > *device-group-name*).
- Step 2** Choose **Configure** > **Acceleration** > **Accelerator Threshold**.
The Accelerator Threshold window appears.
- Step 3** To enable CPU Load Monitoring, check the **Enable** check box. (The default is enabled.)
- Step 4** In the **Accelerator Load Indicator Threshold** field, enter a percent value between 80 and 100. The default is 95.
- Step 5** In the **CPU Load Higher Monitoring Threshold** field, enter a percent value between 1 and 100. The default is 98.
- Step 6** In the In the **CPU Load Lower Monitoring Threshold** field, enter a percent value between 1 and 100. The default is 90.
- Step 7** In the **Window Size** field enter a value between 1 to 16. The default value is 4.

- Step 8** In the **Sampling Intervals Avg Time** field enter a value between 1 and 120. The default is 10.
- Step 9** In the **Overloaded State Time** field, enter a value between 1 to 120. The default value is 10.
- Step 10** Click **Submit**.
- If the device group has the 6.x software image, you can configure additional settings to monitor the cpu load for the device group.
- Step 11** To enable CPU Load Monitoring, check the **Enable** check box. (The default is enabled.)
- Step 12** To enable softirq monitoring , check the **Enable softirq Monitoring** checkbox.
- Step 13** In the **Accelerator Load Indicator Threshold** field, enter a percent value between 80 and 100. The default is 95.
- Step 14** In the **CPU Load Monitoring Threshold** field, enter a percent value between 80 and 100. The default is 95.
- Step 15** In the **CPU Load Higher Monitoring Threshold** field, enter a percent value between 1 and 100. The default is 98.
- Step 16** In the In the **CPU Load Lower Monitoring Threshold** field, enter a percent value between 1 and 100. The default is 90.
- Step 17** In the **Window Size** field enter a value between 1 to 16. The default value is 4.
- Step 18** In the **Sampling Intervals Avg Time** field enter a value between 1 and 120. The default is 10.
- Step 19** In the **Overloaded State Time** field, enter a value between 1 to 120. The default value is 10.
- Step 20** Click **Submit**.

Viewing a List of Applications

To view a list of applications that reside on a WAE device or device group, follow these steps:

- Step 1** From the WAAS Central Manager menu, choose **Devices** > *device-name* (or **Device Groups** > *device-group-name*).
- Step 2** Choose **Configure** > **Acceleration** > **Optimization Policies**.
The Optimization Policies window appears.
- Step 3** Click the Application column header to sort the column by application name so that you can locate a specific application more easily.



Note If there are WAAS Version 4.x devices, click the **Legacy View** taskbar icon to view the policies as they appear in a WAAS Version 4.x device.

To edit an optimization policy, check the box next to the application and click the **Edit** taskbar icon.

If you determine that one or more policies are not needed, check the check box next to each of these applications and click the **Delete** taskbar icon.

If you determine that a new policy is needed, click the **Add Policy Rule** taskbar icon (see [Creating an Optimization Policy](#)).

Viewing a Policy Report

To view a report of a policy residing on each WAE device or device group, follow these steps:

- Step 1** From the WAAS Central Manager menu, choose **Configure > Acceleration > Optimization Policy Report** (Figure 12-32).

The Policy Report for Devices tab appears. This report lists each device (or device group) and the overall policy count on the device (or device group) referencing this application. It includes both active policies (those in use by the device or device group), and backup policies (those not in use by the device when the device gets its configuration from a device group). When the device is deassigned from the device group, the backup policies are applied back to the device and become active again.

An application cannot be deleted unless the No. of Policies field is 0.

Figure 12-32 Optimization Policy Report

Name	Type	Active Settings From
WAE-231-03	AppNav Controller	AllWAASGroup (DeviceGroup)
wae-231-02	Application Accelerator	wae-231-02 (Device)

- Step 2** Click the **Policy Report for Device-Groups** tab to view the number of devices per device group and the number of active policies in the device group.
- Step 3** To see the optimization policies that are defined on a particular device or group, click the corresponding device or device group. The policies are displayed in the Optimization Policies window.

For information about viewing a class map report, see [Viewing a Class Map Report](#).

Viewing a Class Map Report

To view a report of the class maps that reside on each WAE device or device group, follow these steps:

- Step 1** From the WAAS Central Manager menu, choose **Configure > Acceleration > Optimization Policy Report**.
- The Policy Report for Devices tab appears.
- Step 2** Click the **Class-Map Report** tab to view a report of the devices and device groups on which the class map is configured.
- Step 3** Select the class map and click the **View** icon to see the devices or device groups on which the class maps reside.

Restoring Optimization Policies and Class Maps

The WAAS system allows you to restore the predefined policies and class maps that shipped with the WAAS system. For a list of the predefined policies, see [Appendix A, “Predefined Optimization Policy.”](#)

If you made changes to the predefined policies that have negatively impacted how a WAAS device handles application traffic, you can override your changes by restoring the predefined policy settings.

To restore predefined policies and class maps, follow these steps:

-
- Step 1** From the WAAS Central Manager menu, choose **Devices** > *device-name* (or **Device Groups** > *device-group-name*).
 - Step 2** Choose **Configure** > **Acceleration** > **Optimization Policies**.
The Optimization Policies window appears.
 - Step 3** Click the **Restore Default** taskbar icon to restore over 150 policies and class maps that shipped with the WAAS software and remove any new policies that were created on the system. If a predefined policy has been changed, these changes are lost and the original settings are restored.
-

Monitoring Applications and Class Maps

After you create an optimization policy, you should monitor the associated application to make sure your WAAS system is handling the application traffic as expected.

To monitor an application, you must have enabled statistics collection for that application, as described in the [Creating an Application Definition](#).

To monitor a class map, from the WAAS Central Manager menu, choose **Configure** > **Acceleration** > **Monitor Classmaps**. Select the class map on which to enable statistics and click the **Enable** button.

The WAAS Central Manager GUI can display statistics for up to 25 applications and 25 class maps. An error message is displayed if you try to enable more than 25 statistics for either. However, you can use the WAAS CLI to view statistics for all the applications that have policies on a specific WAAS device. For more information, refer to the [Cisco Wide Area Application Services Command Reference](#).

You can use the TCP Summary report to monitor a specific application. For more information, see the [TCP Summary Report](#) in Chapter 15, “Monitoring and Troubleshooting Your WAAS Network.”

Most charts can be configured to display Class Map data by clicking the **chart Edit** icon and choosing the **Classifier** series.

Defining Default DSCP Marking Values

According to policies that you define in an application definition and an optimization policy, the WAAS software allows you to set a DSCP value on packets that it processes.

A DSCP value is a field in an IP packet that enables different levels of service to be assigned to the network traffic. The levels of service are assigned by marking each packet on the network with a DSCP code and associating a corresponding level of service. The DSCP marking determines how packets for a connection are processed externally to WAAS. DSCP is the combination of IP Precedence and Type of Service (ToS) fields. For more information, see RFC 2474. DSCP values are predefined and cannot be changed.

This attribute can be defined at the following levels:

- **Global**—You can define global defaults for the DSCP value for each device (or device group) in the Optimization Policies page for that device (or device group). This value applies to the traffic if a lower level value is not defined.
- **Policy**—You can define the DSCP value in an optimization policy. This value applies only to traffic that matches the class maps defined in the policy and overrides the application or global DSCP value.

This section contains the following topic:

- [Defining the Default DSCP Marking Value](#)

Defining the Default DSCP Marking Value

To define the global default DSCP marking value, follow these steps:

-
- Step 1** From the WAAS Central Manager menu, choose **Devices** > *device-name* (or **Device Groups** > *device-group-name*).
- Step 2** Choose **Configure** > **Acceleration** > **Optimization Policies**.
The Optimization Policies window appears.
- Step 3** Choose a value from the DSCP drop-down list. The default setting is copy, which copies the DSCP value from the incoming packet and uses it for the outgoing packet.
- Step 4** Click **OK** to save the settings.
-

Modifying the Position of an Optimization Policy

Each optimization policy has an assigned position that determines the order in which a WAAS device refers to the policy in an attempt to classify traffic. For example, when a WAAS device intercepts traffic, it refers to the first policy in the list to try to match the traffic to an application. If the first policy does not provide a match, the WAAS device moves on to the next policy in the list.

You should consider the position of policies that pass through traffic unoptimized because placing these policies at the top of the list can cancel out optimization policies that appear farther down the list. For example, if you have two optimization policies that match traffic going to IP address 10.10.10.2, and one policy optimizes this traffic and a second policy in a higher position passes through this traffic, then all traffic going to 10.10.10.2 will go through the WAAS system unoptimized. For this reason, you should make sure that your policies do not have overlapping matching conditions, and you should monitor the applications you create to make sure that WAAS is handling the traffic as expected. For more information on monitoring applications, see [Chapter 15, “Monitoring Your WAAS Network.”](#)

To modify the position of an optimization policy, follow these steps:

-
- Step 1** From the WAAS Central Manager menu, choose **Devices** > *device-name* (or **Device Groups** > *device-group-name*).
- Step 2** Choose **Configure** > **Acceleration** > **Optimization Policies**.
The Optimization Policies window appears ([Figure 12-33](#)).



Note For a WAAS Express device, all policies are grouped under the `waas_global` category.

For a list of predefined policies, see [Appendix A, “Predefined Optimization Policy.”](#)

Figure 12-33 Optimization Policies Window

Position	Class-Map	Source IP	Destination IP	Source Ports	Destination P...	Protocol	Application
1	MS-Exchange-Directory-RFR					ms-rfr	Email-and-Mes...
2	MS-SQL-RPC					ms-sql	SQL
3	MAPI					mapi	Email-and-Mes...
4	MS-AD-Replication					ms-ad-rep	Replication
5	MS-FRS					ms-fis	Replication
6	MS-Exchange-Directory-NSPI					ms-exch-nspi	Email-and-Mes...
7	AFS			7000 - 7009			File-System
8	AOL			5190 - 5193			Instant-Messa...

Step 3 Modify the position of the optimization policy in any of the following ways:

- Select the policy you want to move and use the up and down arrow () icons in the taskbar to move that policy higher or lower in the list.
- Select the policy you want to move and click **Move To** to specify the exact position.
- Select the policy and drag and drop it into the desired position



Note The **Save Moved Rows** icon must be clicked to save the new policy positions.

You can also create a new optimization policy at a particular position by selecting the policy above the location and then clicking **Insert**.

If a device goes through all the policies in the list without making a match, the WAAS device passes through the traffic unoptimized.



Note For a WAAS Express device, the class default policy should be last. This policy cannot be modified or deleted.

Step 4 Click the **Save Moved Rows** icon to save changes, if any, that you made to policy positions.

Step 5 If you determine that a policy is not needed, follow these steps to delete the policy:

- a. Select the policy you want to delete.
- b. Click the **Delete** icon in the taskbar.



Note A default policy that maps to a default class map matching any traffic cannot be deleted.

- Step 6** If you determine that a new policy is needed, click the **Add Policy** taskbar icon to create the policy (see [Creating an Optimization Policy](#)).
-

Modifying the Acceleration TCP Settings

In most cases, you do not need to modify the acceleration TCP settings because your WAAS system automatically configures the acceleration TCP settings based on the hardware platform of the WAE device. WAAS automatically configures the settings only under the following circumstances:

- When you first install the WAE device in your network.
- When you enter the **restore factory-default** command on the device. For more information about this command, see the [Cisco Wide Area Application Services Command Reference](#).

The WAAS system automatically adjusts the maximum segment size (MSS) to match the advertised MSS of the client or server for each connection. The WAAS system uses the lower of 1432 or the MSS value advertised by the client or server.

If your network has high BDP links, you may need to adjust the default buffer settings automatically configured for your WAE device. For more information, see [Calculating the TCP Buffers for High BDP Links](#).

If you want to adjust the default TCP adaptive buffering settings for your WAE device, see [Modifying the TCP Adaptive Buffering Settings](#).

To modify the acceleration TCP settings, follow these steps:

-
- Step 1** From the WAAS Central Manager menu, choose **Devices > device-name** (or **Device Groups > device-group-name**).
- Step 2** Choose **Configure > Acceleration > TCP Settings**. The Acceleration TCP Settings window appears.
- Step 3** Check the **Send TCP Keepalive** check box. (By default, this check box is checked.)
- Checking the **Send TCP Keepalive** check box allows this WAE device or group to disconnect the TCP connection to its peer device if no response is received from the TCP keepalive exchange. In this case, the two peer WAE devices will exchange TCP keepalives on a TCP connection, and if no response is received for the keepalives for a specific period, the TCP connection will be torn down. When the keepalive option is enabled, any short network disruption in the WAN will cause the TCP connection between peer WAE devices to be disconnected.
- If the Send TCP Keepalive check box is not checked, TCP keepalives will not be sent and connections will be maintained unless they are explicitly disconnected.
- Step 4** Modify the TCP acceleration settings, as needed. See [Table 12-9](#) for a description of these settings.
- For information on how to calculate these settings for high BDP links, see [Calculating the TCP Buffers for High BDP Links](#).

Table 12-8 TCP Settings

TCP Setting	Description
Optimized Side	
Maximum Segment Size	Maximum packet size allowed between a WAAS device and other WAAS devices participating in the optimized connection. The default is 1432 bytes.
Send Buffer Size	Allowed TCP sending buffer size (in kilobytes) for TCP packets sent from a WAAS device to other WAAS devices participating in the optimized connection. The default is 32 KB.
Receive Buffer Size	Allowed TCP receiving buffer size (in kilobytes) for incoming TCP packets from other WAAS devices participating in the optimized connection. The default is 32 KB.
Original Side	
Maximum Segment Size	Maximum packet size allowed between the origin client or server and a WAAS device. The default is 1432 bytes.
Send Buffer Size	Allowed TCP sending buffers size (in kilobytes) for TCP packets sent from a WAAS device to the origin client or server. The default is 32 KB.
Receive Buffer Size	Allowed TCP receiving buffer size (in kilobytes) for incoming TCP packets from the origin client or server. The default is 32 KB.

Step 5 If you are deploying the WAE across a high Bandwidth-Delay-Product (BDP) link, you can set recommended values for the send and receive buffer sizes by clicking **Set High BDP recommended values**. For more information about calculating TCP buffers for high BDP links, see [Calculating the TCP Buffers for High BDP Links](#).

Step 6 Click **Submit**.

**Note**

If the original and optimized maximum segment sizes are set to their default values and you configure a jumbo MTU setting, the segment sizes are changed to the jumbo MTU setting minus 68 bytes. If you have configured custom maximum segment sizes, their values are not changed if you configure a jumbo MTU. For more information on jumbo MTU, see [Configuring a Jumbo MTU](#) in Chapter 6, “Configuring Network Settings.”

To configure TCP keepalives from the CLI, use the **tfo tcp keepalive** global configuration command.

To configure TCP acceleration settings from the CLI, use the following global configuration commands: **tfo tcp optimized-mss**, **tfo tcp optimized-receive-buffer**, **tfo tcp optimized-send-buffer**, **tfo tcp original-mss**, **tfo tcp original-receive-buffer**, and **tfo tcp original-send-buffer**.

To show the TCP buffer sizes, use the **show tfo tcp EXEC** command.

Calculating the TCP Buffers for High BDP Links

WAAS software can be deployed in different network environments, involving multiple link characteristics such as bandwidth, latency, and packet loss. All WAAS devices are configured to accommodate networks with maximum Bandwidth-Delay-Product (BDP) of up to the values listed below:

- WAE-512—Default BDP is 32 KB
- WAE-612—Default BDP is 512 KB
- WAE-674—Default BDP is 2048 KB
- WAE-7341—Default BDP is 2048 KB
- WAE-7371—Default BDP is 2048 KB
- All WAVE platforms—Default BDP is 2048 KB

If your network provides higher bandwidth, or higher latencies are involved, use the following formula to calculate the actual link BDP:

$$\text{BDP [Kbytes]} = (\text{link BW [Kbytes/sec]} * \text{Round-trip latency [Sec]})$$

When multiple links 1..N are the links for which the WAE is optimizing traffic, the maximum BDP should be calculated as follows:

$$\text{MaxBDP} = \text{Max} (\text{BDP}(\text{link } 1), \dots, \text{BDP}(\text{link } N))$$

If the calculated MaxBDP is greater than the DefaultBDP for your WAE model, the Acceleration TCP settings should be modified to accommodate that calculated BDP.

After you calculate the size of the Max BDP, enter a value that is equal to or greater than twice the Max BDP in the Send Buffer Size and Receive Buffer Size fields for the optimized connection on the Acceleration TCP Settings window.

Note

These manually configured buffer sizes are applicable only if TCP adaptive buffering is disabled. TCP adaptive buffering is normally enabled, and allows the WAAS system to dynamically vary the buffer sizes. For more information on TCP adaptive buffering, see [Modifying the TCP Adaptive Buffering Settings](#).

Modifying the TCP Adaptive Buffering Settings

In most cases, you do not need to modify the acceleration TCP adaptive buffering settings because your WAAS system automatically configures the TCP adaptive buffering settings based on the network bandwidth and delay experienced by each connection. Adaptive buffering allows the WAAS software to dynamically vary the size of the send and receive buffers to increase performance and more efficiently use the available network bandwidth.

To modify the acceleration TCP adaptive buffering settings, follow these steps:

-
- Step 1** From the WAAS Central Manager menu, choose **Devices > device-name** (or **Device Groups > device-group-name**).
 - Step 2** Choose **Configure > Acceleration > TCP Adaptive Buffering Settings**.
The TCP Adaptive Buffering Settings window appears.
 - Step 3** To enable TCP adaptive buffering, check the **Enable** check box. (By default, this is enabled.)
 - Step 4** In the Send Buffer Size and Receive Buffer Size fields, enter the maximum size, in kilobytes, of the send and receive buffers.
 - Step 5** Click **Submit**.
-

To configure the TCP adaptive buffer settings from the CLI, use the **tfo tcp adaptive-buffer-sizing** global configuration command:

```
WAE(config)# tfo tcp adaptive-buffer-sizing receive-buffer-max 8192
```

To disable TCP adaptive buffering from the CLI, use the **no tfo tcp adaptive-buffer-sizing enable** global configuration command.

To show the default and configured adaptive buffer sizes, use the **show tfo tcp EXEC** command.



Configuring Cisco WAAS with Akamai Connect

This chapter describes how to configure Cisco WAAS with Akamai Connect, which is an integrated solution that combines WAN optimization and intelligent object caching to accelerate HTTP/S applications, video, and content.



Note

Throughout this chapter, the term Cisco WAAS device is used to refer collectively to the Cisco Wide Area Application Services (Cisco WAAS) Central Managers and Cisco Wide Area Application Engines (WAEs) in your network. The term WAE refers to WAE and Cisco Wide Area Virtualization Engine (WAVE) appliances, Cisco Services Ready Engine (SRE) service modules (SMs) running WAAS, and Cisco Virtual WAAS (vWAAS) instances.

This chapter contains the following sections:

- [Benefits of Cisco WAAS with Akamai Connect](#)
- [Deployment Options for Cisco WAAS with Akamai Connect](#)
- [Operating Considerations for Cisco WAAS with Akamai Connect](#)
- [Supported WAAS Platforms for Akamai Connect](#)
- [Workflow for Enabling and Using Akamai Connect](#)
- [Enabling Akamai Connect and Activating Akamai Connect License](#)
- [Enabling Akamai Connected Cache](#)
- [Enabling OTT Caching](#)
- [Caching Types and Setting Caching Policies](#)
- [Using HTTP Proxy for Connections to the Akamai Network](#)
- [Cisco Cloud Web Security and Force IMS Features](#)
- [Configuring Cache Prepositioning for Akamai Connect](#)
- [Configuring HTTP/S Preposition Proxy for Akamai Connect](#)
- [Cisco Support for Microsoft Windows Update](#)



Note

Akamai Connect is the HTTP/S object cache component added to Cisco WAAS, integrated into the existing WAAS software stack and leveraged via the HTTP Application Optimizer. WAAS with Akamai Connect helps to reduce latency for HTTP/S traffic for business and web applications.

Akamai Connected Cache is a component of Akamai Connect, which allows the Cache Engine to cache content that is delivered by an Edge server on the Akamai Intelligent Platform.

Benefits of Cisco WAAS with Akamai Connect

The Akamai Connect feature is an HTTP/HTTPS object cache component that is added to Cisco WAAS. It is integrated into the existing WAAS software stack and is leveraged via the HTTP Application Optimizer.

Akamai Connect helps reduce latency for HTTP/HTTPS traffic for business and web applications, and can improve performance for many applications, including Point of Sale (POS), HD video, digital signage, and in-store order processing. It provides significant and measurable WAN data offload, and is compatible with existing WAAS functions such as DRE (deduplication), LZ (compression), TFO (Transport Flow Optimization), and SSL acceleration (secure/encrypted) for first and second pass acceleration.

The following are some of the benefits of adding Akamai Connect to WAAS:

- Intelligent transparent object caching (by integrating Akamai's cache).
- Seamless integration of Akamai Connect in WAAS software and configuration (with WAAS Central Manager and WAAS CLI).
- Integration with Akamai's Edge Grid Network, which provides low-latency Content Delivery Network transfers (via Akamai Connected Cache).
- Significant and measurable WAN data offload.
- Cache repositioning (warming) for websites that you specify.
- Hostname rules for cache control of specific websites or domains.
- First and second pass acceleration, because Akamai Connect works with WAAS middle-mile capabilities (including DRE, LZ, TFO, and SSL acceleration).
- Dual-sided or single-sided network deployment.

Deployment Options for Cisco WAAS with Akamai Connect

This section contains the following topics:

- [Dual-Sided Deployment](#)
- [Single-Sided Deployment](#)

Dual-Sided Deployment

Dual-sided deployment ([Figure 13-1](#)) provides the benefits of WAAS technology plus Akamai caching for HTTP and HTTPS traffic:

- Transparent caching of customer-owned, Intranet web resources
- Caching in branch only.
- Includes repositioning (for non-SSL content).

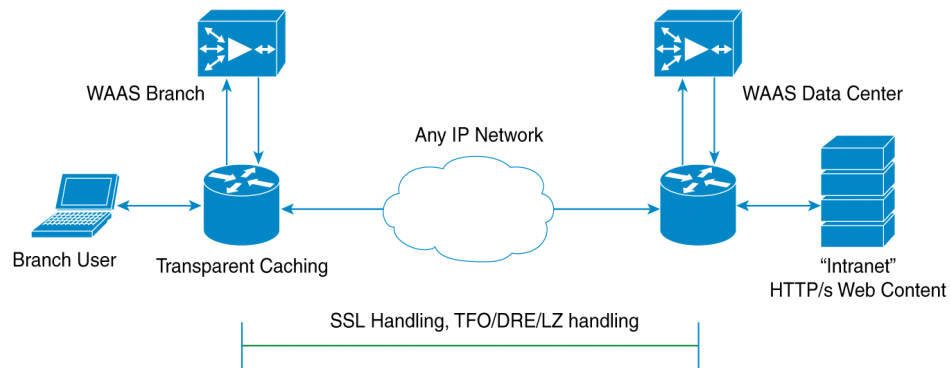
Figure 13-1 Dual-sided Deployment

392020

Single-Sided Deployment

Single-sided deployment (Figure 13-2) provides the benefits of WAAS technology plus Akamai caching for HTTP and HTTPS traffic:

the benefits of HTTP object caching.

- Generic web resources that utilize proxy-specific HTTP cache-control headers.
- Caching in branch only.
- Includes prepositioning (for non-SSL content).
- Single-sided deployment is on by default with transparent caching in Standard mode.

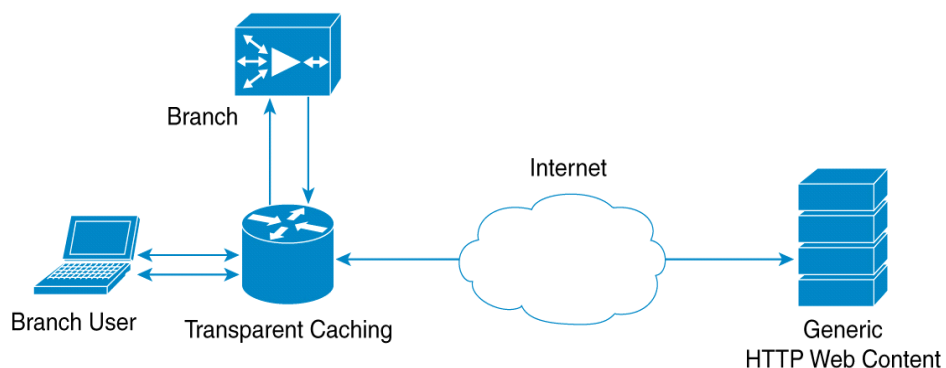
Figure 13-2 Single-sided Deployment

392021

Operating Considerations for Cisco WAAS with Akamai Connect

Consider the following when using Cisco WAAS with Akamai Connect:

- You cannot view the contents of the cache, and cannot pin content to make it remain in the cache, for example, for prepositioned content.

- There is no separate cache for HTTPS content. However, data is stored differently for the same site if both HTTP and HTTPS are accessing. (The way the sites are stored in the cache is based on the URL, and this will change between HTTP and HTTPS.)

The Cache Engine has no explicit integration with AppNav. The AppNav status is based on the HTTP application accelerator.

**Note**

The terms *mode*, *profile*, and *policy* are sometimes used interchangeably to describe caching types and processes. This document uses these terms as follows:

Mode—The version of transparent caching (Basic, Standard, Advanced, or Bypass).

Profile—The set of host rules and caching types applied as a group, and which follows the Cache Engine order of precedence.

Policy—The set of rules and the conditions of caching, applied either singly or as a group, to device or device group.

Supported WAAS Platforms for Akamai Connect

The flow of allocated resources to the Akamai Cache Engine is controlled by the WAAS Central Manager, but the overall resource pool and the amount of resources that can be allocated to the Akamai Cache Engine is controlled by the hardware platform, and the number of supported connections and users that the router is designed to service.

This section contains the following topics:

- [Supported WAAS Platforms for Akamai Connect up to 6,000 Connections](#)
- [Supported WAAS Platforms for Akamai Connect beyond 6,000 Connections](#)

Supported WAAS Platforms for Akamai Connect up to 6,000 Connections

Table 13-1 shows the supported WAAS platforms for Akamai caching up to 6,000 connections, for WAAS Version 5.4.1 and later. For details on supported WAAS platforms beyond 6,000 connections, see [Supported WAAS Platforms for Akamai Connect beyond 6,000 Connections](#).

Table 13-1 Supported WAAS Platforms for Akamai Caching up to 6,000 Connections

Appliance	SM	vWAAS	ISR-WAAS
		vWAAS-150	ISR-G2 and ISR-G3
WAVE-294	SM-700	vWAAS-200	ISR-WAAS-750 (ISR-4451, ISR-4431, ISR-4351, ISR-4331, ISR-4321)
WAVE-594	SM-900	vWAAS-750	ISR-WAAS-1300 (ISR-4451, ISR-4431)

Appliance	SM	vWAAS	ISR-WAAS
WAVE-694	SM-710	vWAAS-1300	ISR-WAAS-2500 (ISR-4451)
	SM-910	vWAAS-2500	
		vWAAS-6000	

**Note**

If you are upgrading from a version earlier than vWAAS Version 5.4, you will need a third disk and possibly more memory added. For more information, see the [Akamai Connect and vWAAS](#) section of the *Cisco Wide Area Application Services vWAAS Installation and Configuration Guide*.

Supported WAAS Platforms for Akamai Connect beyond 6,000 Connections

The flow of allocated resources to the Akamai Cache Engine is controlled by the WAAS Central Manager, but the overall resource pool and the amount of resources that can be allocated to the Akamai Cache Engine is controlled by the hardware platform, and the number of supported connections and users that the router is designed to service. For supported WAAS platforms up to 6,000 connections, see [Supported WAAS Platforms for Akamai Connect up to 6,000 Connections](#).

This section contains the following topics:

- [WAVE and vWAAS Models for Akamai Connect beyond 6,000 Connections](#)
- [Configuring HTTP-OC on WAVE-7541/7571/8541](#)
- [Configuring HTTP-OC on vWAAS-12000/50000](#)

WAVE and vWAAS Models for Akamai Connect beyond 6,000 Connections

For WAAS Version 6.2.1 and later, the Akamai Connect Cache Engine is supported for scaling beyond 6,000 connections on the following platforms:

- WAVE-7541, WAVE-7571, and WAVE-8541
- vWAAS-12000 and vWAAS-50000

[Table 13-2](#) shows supported vWAAS models for Akamai caching beyond 6,000 connections, and disk and memory requirements for Akamai caching beyond 6,000 connections

Table 13-2 Supported vWAAS Models and Memory/Disk Requirements for Akamai Connect beyond 6,000 Connections

vWAAS Model	Total HTTP Object Cache Connections (K)	Cache Engine Cache Disk (GB)	Additional Resource to be Added
vWAAS-12000	12	750	6GB RAM, 750 GB disk
vWAAS-50000	50	850	850 GB disk

**Note**

For vWAAS with WAAS Version 6.2.x, vWAAS with Akamai Connect beyond 6,000 connections is not supported for Cisco vWAAS on RHEL KVM or KVM on CentOS.

**Caution**

When a WAE—a WAVE model used for Akamai Connect beyond 6,000 connections—is assigned to a device group in the WAAS Central Manager *after* Akamai Connect is already enabled, you must manually reload the device. Akamai Connect will remain in shutdown state until the reload is performed.

Scaling for these platforms is based on memory availability and scale performance. [Table 13-3](#) shows the total HTTP object cache connections, memory required for the cache engine, cache engine cache disk, and additional resources, if needed.

The Akamai Connect Cache Engine connection-handling capacity is determined by the upper limit of memory that is given to the Akamai Connect Cache Engine at startup. The Akamai Connect Cache Engine will allocate memory as needed up to the upper limit. In case of overload, the connection will be optimized by HTTP-AO, without a caching benefit.

**Note**

For vWAAS-12000 and vWAAS-50000, HTTP object cache will scale up to the platform TFO limit. To achieve this, you must augment the platform resources (CPU, RAM, and disk) during provisioning.

For vWAAS-12000, you must allocate at least 6 GB of additional RAM.

For vWAAS-1200 and vWAAS-50000, you must allocate Cache Engine cache disk resources. Cache disk requirements are shown in [Table 13-3](#).

Table 13-3 WAAS Mid to High End Platform Memory/Disk Requirements for HTTP-OC

Cisco WAAS Platform	Total HTTP Object Cache Connections (K)	Cache Engine Cache Disk (GB)	Additional Resource to be Added
WAVE-7541	18	708	N/A
WAVE-7571	45	839	N/A
WAVE-8541	112	675	N/A
vWAAS-12000	12	1500	6GB RAM, 750 GB disk
vWAAS-50000	50	2350	850 GB disk

Configuring HTTP-OC on WAVE-7541/7571/8541

Configuring HTTP-OC on WAVE-7541, WAVE-7571 or WAVE-8541 includes configuring the Device Profile feature and re-partitioning the WAVE disk.

- **Device Profile** (WAAS Version 6.2.1 and later)—The Device Profile feature enables the device mode as “branch” which tunes the resource allocation for various WAAS services as a branch traffic scenario and branch services. Device Profile is enabled at the *individual device* level; it is not enabled for an entire device group.
- **Data Disk Partitions** (WAAS Version 6.2.1 and later)—To accommodate the larger-scale connections available for WAAS Version 6.2.1 with Akamai Connect, the single partition for the RAID5-based disk subsystem is split into multiple partitions.

To configure HTTP-OC on WAVE-7541, WAVE-7571 or WAVE-8541, follow these steps.

- Step 1** Upgrade the WAAS Central Manager and WAE devices to WAAS Version 6.2.1 or later.
- For complete upgrade instructions, including critical prerequisites before upgrading the WAAS Central Manager to WAAS Version 6.2.1 or later, see the Release Note for Cisco Wide Area Application Services for your WAAS release.
- After upgrade, the Device Profile feature—**Device** > *device-name* > **Configure** > **Caching** > **Device Profile**—is initially disabled, and the **Branch** check box in the Device Profile screen section is unchecked. See Step for how to enable Device Profile after an upgrade.
- Step 2** After upgrade is complete enable HTTP-OC, from the WAAS Central Manager or from the WAAS CLI.
- Step 3** When you enable HTTP-OC for WAVE-7541/7571/8541, you will receive a message to run the **disk delete-data-partitions EXEC** command and to restart the system.



Note The **disk delete-data-partitions** command deletes all data partitions on all logical drives, including CONTENT, PRINTSPOOL, and SYSFS partitions. These partitions include all DRE and SMB object cache files, SYSFS and print spool files. New partitions are created at system restart.

- Step 4** Upgrading the system and configuring HTTP-OC from the WAAS Central Manager (to upgrade from the WAAS CLI, see [Step 5](#)):
- Enable Akamai Connect.
 - A message is displayed with two requirements, for disk delete data partitions and Device Profile enable, and includes an approval request for these.
 - After user approval, the WAAS Central Manager will initiate disk delete data partitions process and enable the Device Profile feature.
 - Restart the system.
 - By default, from the WAAS Central Manager, Akamai Connect will be enabled at restart.



Note For WAVE models 7541 and 8541, the Device Profile feature is automatically set/unset when you enable/disable HTTP OC. For WAVE-7571, the Device Profile setting requires you to reboot to change the Device Profile feature status.

- Step 5** Upgrading the system and configuring HTTP-OC from the CLI (to upgrade from the WAAS Central Manager, see [Step 4](#)):
- Enable Akamai Connect.
 - A message is displayed to run the **disk delete-data-partitions EXEC** command.
 - By default, from the CLI, Akamai Connect is not enabled at system restart.
 - Enable Akamai Connect.
 - Here are operating considerations when Akamai Connect is enabled:
 - You can disable the Device Profile feature if you disable Akamai Connect on the device. To disable the Device Profile feature, uncheck the **Branch** check box.
 - For WAVE models 7541 and 8541, the Device Profile feature is automatically set/unset when you enable/disable HTTP OC. For WAVE-7571, the Device Profile setting requires you to reboot to change the Device Profile feature status.

- You can disable the Device Profile feature if you disable Akamai Connect on the device. To disable the Device Profile feature, uncheck the **Branch** check box.
- To enable the Device Profile feature from the CLI, use the **device mode** global configuration command, to configure the device to function as application accelerator (**application-accelerator**) or WAAS Central Manager (**central-manager**).



Note For the WAVE-7571, you can also use the device mode command to configure the device to function as a branch device (profile-branch), to configure pre-allocation resources for various WAAS services to be branch traffic scenario and branch services.

The branch profile enabled connection count used for computing memory for pre-allocation is 3/4 of the TFO limit.

- f. To show device profile settings, use the **show device-mode current** EXEC command.
- g. To show the configured device mode (the mode that is configured but has not yet taken effect), use the **show device-mode configured** EXEC command.

Configuring HTTP-OC on vWAAS-12000/50000

As noted in the procedure [Configuring HTTP-OC on WAVE-7541/7571/8541](#), the process includes running the **disk delete-data-partitions** EXEC command and restarting the system. The **disk delete-data-partitions** command deletes all data partitions on all logical drives, including CONTENT, PRINTSPOOL, and SYSFS partitions. These partitions include all DRE and SMB object cache files, SYSFS and print spool files. New partitions are created at system restart.

To configure HTTP-OC on vWAAS-12000 or vWAAS-50000 and to avoid object and DRE caching being lost due to execution of the the **disk delete-data-partitions** command, you must downgrade from WAAS Version 6.2.x to WAAS Version 5.x, and then upgrade to WAAS Version 6.2.x. Use one of the following downgrade/upgrade procedures:

- [Downgrade/Upgrade with Additional Akamai Cache Disk Removed/Reinstalled](#)
- [Downgrade/Upgrade with Additional Akamai Cache Disk Remaining In Place](#)

Downgrade/Upgrade with Additional Akamai Cache Disk Removed/Reinstalled

To configure HTTP-OC on vWAAS-12000 or vWAAS-50000 with the additional Akamai Cache disk removed and then reinstalled, follow these steps:

-
- Step 1** The device is at WAAS Version 6.2.x, with Akamai Connect enabled.
 - Step 2** Disable Akamai Connect.
 - Step 3** Power down the device.
 - Step 4** Remove the additional Akamai Cache disk.
 - Step 5** Power on the device.
 - Step 6** Downgrade from WAAS Version 6.2.x WAAS Version 5.x.
 - Step 7** Upgrade the WAAS Central Manager and WAE devices to WAAS Version 6.2.x.
 - Step 8** After upgrade is complete, power off the device.

-
- Step 9** Re-install the additional Akamai Cache disk.
 - Step 10** Power on the device.
 - Step 11** Enable Akamai Connect.
 - Step 12** Enable HTTP-OC from the WAAS Central Manager or from the WAAS CLI.
 - Step 13** A message is displayed regarding the required additional memory and disk resources (shown in [Table 13-3](#)).
 - Step 14** Power down the vWAAS VM and add the necessary resources the vWAAS VM.
 - Step 15** Power up the vWAAS VM.
 - Step 16** HTTP-OC is enabled on the vWAAS.
-

Downgrade/Upgrade with Additional Akamai Cache Disk Remaining In Place

To configure HTTP-OC on vWAAS-12000 or vWAAS-50000 with the additional Akamai Cache disk remaining in place, follow these steps:

-
- Step 1** Upgrade the WAAS Central Manager and WAE devices to WAAS Version 6.2.1 or later.
 - Step 2** Enable Akamai Connect.
 - Step 3** Downgrade from WAAS Version 6.2.x to WAAS Version 5.x.
 - Step 4** Upgrade the WAAS Central Manager and WAE devices to WAAS Version 6.2.x.
 - Step 5** Run the **disk delete-data-partitions** EXEC command and restart the system.
 - From the CLI, a message is displayed to run the **disk delete-data-partitions** EXEC command and restart the system.
 - The WAAS Central Manager does not display this message.



Note After the upgrade, You must run the **disk delete-data-partitions** command to enable Akamai Connect.



Note The **disk delete-data-partitions** command deletes all data partitions on all logical drives, including CONTENT, PRINTSPOOL, and SYSFS partitions. These partitions include all DRE and SMB object cache files, SYSFS and print spool files. New partitions are created at system restart.

- Step 6** Enable Akamai Connect.
-

Workflow for Enabling and Using Akamai Connect

Table 13-4 Workflow for Enabling and Using Akamai Connect

Task	Section
1. Confirm that your WAAS configuration has all requisite components to work with Akamai Connect.	<ul style="list-style-type: none"> Supported WAAS Platforms for Akamai Connect Prerequisites for WAAS with Akamai Connect
2. Enable Akamai Connect.	<ul style="list-style-type: none"> Enabling Akamai Connect
3. Register and activate Akamai Connect.	<ul style="list-style-type: none"> Activating the Akamai Connect License
4. Enable Akamai Connected Cache.	<ul style="list-style-type: none"> Enabling Akamai Connected Cache
5. (Optional) Enable OTT caching.	<ul style="list-style-type: none"> Enabling OTT Caching
6. (If needed) De-register and re-register a WAAS device.	<ul style="list-style-type: none"> Deregistering and Reregistering a WAAS Device
7. (If needed) Replace an expired Akamai Connect license.	<ul style="list-style-type: none"> Replacing an Inactive or Expired Akamai Connect License
8. Set one caching policy for all sites.	<ul style="list-style-type: none"> Caching Types and Setting Caching Policies
9. Set an individual caching policy for specific sites.	<ul style="list-style-type: none"> Caching Types and Setting Caching Policies
10. Set Force IMS policies.	<ul style="list-style-type: none"> Cisco Cloud Web Security and Force IMS Features
11. Configure cache prepositioning	<ul style="list-style-type: none"> Configuring Cache Prepositioning for Akamai Connect
12. View cache prepositioning status.	<ul style="list-style-type: none"> Viewing Cache Prepositioning Task Status
13. (Optional) Copy cache prepositioning tasks.	<ul style="list-style-type: none"> Copying Cache Prepositioning Tasks
14. (Optional) Configure HTTP/S preposition proxy.	<ul style="list-style-type: none"> Configuring HTTP/S Preposition Proxy for Akamai Connect
15. View Akamai Connected Cache Statistics.	<ul style="list-style-type: none"> Akamai Connected Cache Charts in Chapter 15, “Monitoring Your WAAS Network”
16. (If needed) Set up HTTP proxy connections to the Akamai network.	<ul style="list-style-type: none"> Using HTTP Proxy for Connections to the Akamai Network

Enabling Akamai Connect and Activating Akamai Connect License

This section contains the following topics:

- Prerequisites for WAAS with Akamai Connect
- Enabling Akamai Connect
- Activating the Akamai Connect License
- Deregistering and Reregistering a WAAS Device

- [Replacing an Inactive or Expired Akamai Connect License](#)

Prerequisites for WAAS with Akamai Connect

Before you enable Akamai Connect, confirm that your WAAS configuration has the following:

- The WAAS Central Manager and WAAS appliances are updated to software version 5.5.1 or later.
- A verified NTP service that is within 30 seconds of the NTP standard server (NTP.org). For how to configure the NTP server, see [Configuring an NTP Server](#) in Chapter 10, “Configuring Other System Settings.”
- A working public DNS server configured on the WAAS devices and the WAAS Central Manager. For how to configure the DNS server, see [Configuring the DNS Server](#) in Chapter 6, “Configuring Network Settings.”
- The ability for the WAAS Central Manager to reach Akamai’s Luna system via HTTPS on port 443. (The custom hostname is in your activation file.)
- The ability for WAAS devices to make a connection to the Akamai Management Gateway (AMG) to get the authentication key. The WAAS device configured for Akamai Connect needs the correct network connectivity to access the AMG every day to get correct credentials and updated metadata. WAAS will make an HTTPS connection on port 443 to the AMG to get this information.

If the WAAS devices cannot go direct to the Internet, you can configure them to use the WAAS Central Manager as a proxy.



Note The Akamai Connected Cache feature will stop functioning if WAAS loses communication with the AMG for more than 48 hours.

Enabling Akamai Connect

To enable Akamai Connect, follow these steps.

Step 1 From the WAAS Central Manager menu, from either the Device Groups or Devices tab, choose **Configure > Caching > Akamai Connect**.

The Akamai Connect window appears, with two tabs: Cache Settings and Cache Prepositioning.

Step 2 Choose the **Cache Settings** tab.



Note If you are configuring the Akamai Connect feature for a device group, the device group should have only devices that support Akamai Connect. For more information, see [Supported WAAS Platforms for Akamai Connect](#).

Step 3 Check the **Enable Akamai Connect** check box to turn on the Akamai Connect Cache Engine. When the End-User License Agreement (EULA) dialog box appears, click **Accept**.

Step 4 Click **Submit**.



Note When you create settings for the first time, either at the device or the group level, the Akamai license upload file is displayed, and you can select the license file supplied and click **Submit**. For more information on activating the Akamai Connect license, see [Activating the Akamai Connect License](#).



Note Turning on the Cache Engine starts active caching in Standard mode. If you want Advanced or Bypass mode, you must specify it. This step is described in [Setting Caching Policies](#).

Step 5 Continue to **Edit Settings** screen section, described in , or **Advanced Cached Settings** screen section, described in .



Note To edit *any* settings, including advanced settings and cache preposition, the Akamai Connect feature must remain enabled.

Activating the Akamai Connect License

Before you begin the registration process to activate Akamai Connect, confirm the readiness of your WAAS configuration, as described in [Prerequisites for WAAS with Akamai Connect](#).



Note For information on the status of an active Akamai Connect license, see [Akamai Connect Diagnostics Using the Central Manager](#) in Chapter 16, “Troubleshooting Your WAAS Network.”

To receive and activate the Akamai Connect activation file, follow these steps:

- Step 1** Purchase a license for Akamai Connect from your Cisco account representative or reseller.
- Step 2** The account representative or reseller enters the order into the Cisco Commerce Workspace (CCW) system. The order *must* specify an email address for eDelivery of the Activation file.
- Step 3** CCW contacts the Akamai Luna Portal to request a license or licenses for the number and type of Akamai licenses entered.
- Step 4** Akamai generates and sends the license(s) to the CCW system in the form of a single activation file.
- Step 5** The CCW system sends an email, with the activation file attached, to the email address specified in the order. The order of priority for selecting the email address in a CCW order is:
 - Priority1: eDelivery email address
 - Priority2: end customer email address
 - Priority3: shipping contact email address



Note If you do not provide an email address in your order, you will not receive an activation file.

- Step 6** Enable Akamai Caching on each WAE. There are two paths available to reach the Akamai Connect screen. You can use either one to enable Akamai Connect to use any of the transparent caching methods, Akamai Connected Cache, or OTT. If this is the first time you are navigating to the Akamai Connect screen, you will be prompted to provide the activation file for licensing.
- From the WAAS Central Manager choose **Device/Device Group > Configure > Caching > Akamai Connect**.
 - OR
 - From the WAAS Central Manager choose **Home > Admin > Licenses > Akamai Connect**. This path can be used later to add more licenses, if needed.

The Akamai Connect screen is displayed.

- Step 7** At the **Upload Akamai Connect License file** field, click **Browse**, highlight the activation file and click **OK**.

- Step 8** Click **Upload**. The authentication data in the activation file is transmitted to the Akamai Luna portal.

- Step 9** After the device message is sent to the Luna portal:

- The Luna portal sends the Entitlement Code to the WAAS Central Manager and the Akamai Management Gateway (AMG).
- The WAAS Central Manager sends the Entitlement Code to WAAS.
- The AMG rolls out the Entitlement Code to Edge Servers on the Akamai Grid Network.

The Entitlement Code is maintained on Luna, on the AMG, and on the WAAS device. WAAS connects to the AMG using a proxy/DNS server that can resolve the address **amg.terra.akamai.com**.

- Step 10** The list titled **Status of devices with Akamai Connect feature configured** displays the following types of status for one, some, or all devices.

- Akamai Device Status - ActivationInProgress, Active
- Operational Status - Disconnected, Connected, or Running
- Connectivity to Akamai - Activating, Activated, or Connected

The device registration, operational status, and connectivity to Akamai proceed through a set of status indicators for the three status categories: Akamai Device Status/Operational Status/Connectivity to Akamai:

- **ActivationInProgress /Disconnected /Activating**
- **ActivationInProgress /Connected /Activating**
- **Active /Connected /Activated**
- **Active /Connected /Connected**



Note

The activation process for WAAS devices may take between 15-60 minutes to complete, and for this time period, the **Connectivity to Akamai** status displays as **Activating**. During this time, device(s) may not be able to communicate with the Akamai Network, because they are not recognized by the AMGs until the activation process is complete, and the **Connectivity to Akamai** status displays as **Connected**.

- Step 11** For the last steps in the registration process, Luna sends the Connected Cache credentials to the AMG and to the Edge Servers on the Akamai Grid network. The AMG forwards Connected Cache credentials on to WAAS. With the Connected Cache credentials on both WAAS and the Edge Servers, the Connected

Cache is enabled, and caching requests can be served by the Edge servers. This authenticated connection can then service requests for Connected Cache and OTT caching from the Akamai Grid network Edge Servers.

- Step 12** The registration of each WAE begins. The WAAS Central Manager provides information to the Akamai Luna Portal for each device that will be running Akamai Connect.



Note **Connected** Operational Status can take several minutes to complete. Rollout of the activation to the Edge servers can take up to 45 minutes to complete. A device may take from a few minutes to up to two hours to show an **Active** Activation Status, depending on when the request was made, traffic conditions, and other variables.

- Step 13** Each WAE that has been sent the entitlement code will try to make an SSL connection to the AMG using **amg.terra.akamai.com**. The Luna Portal will push out the Akamai Connected Cache credentials to the AMG and Akamai Grid Network (to the Akamai Edge Servers).

- The AMG will push the Akamai Connected Cache credentials out to each of the WAEs that are configured for Akamai Connected Cache. If OTT is enabled, the OTT metadata needed to help cache YouTube objects is also processed at this time.
- The Akamai Connected Cache credentials are sent by the WAE Cache Engine when going to the origin server. If the WAE Cache Engine has valid credentials according to the Akamai Edge Server, the Akamai Edge Server then provides objects to the WAE Cache Engine that are not normally cacheable to other devices.

- Step 14** The WAE Cache Engine will request new credentials daily and will be good for two days. The connections are always established from WAE or WAAS Central Manager over TCP 443 to the AMG.

- For security, firewalls are usually deployed by performing statefull inspection on traffic from within the company to the outside. They are also configured to block unknown traffic from the outside to the inside. Since connection should not initiate from AMG to any WAAS Central Manager or WAE at any time, there should not be an issue. If there is, then a hole will need to be made to allow the WAAS Central Manager or WAE to speak to any device on port 443.



Note The Devices listing on the **All Devices** screen includes a column titled **Akamai Connect**, which shows the status of each device: Active, Not Supported, Connected, Disconnected.

- Step 15** As needed, configure HTTP proxy or external HTTP proxy, as described in [Using HTTP Proxy for Connections to the Akamai Network](#).

Deregistering and Reregistering a WAAS Device

When you deregister a WAAS device from the WAAS Central Manager, the WAAS Central Manager will trigger the removal of the device record on the Akamai side, thereby invalidating the entitlement key used by the Cache Engine to talk to AMG devices. On the WAAS side, the Cache Engine will continue operating in transparent cache mode.

When you reregister a WAAS device with the WAAS Central Manager, one of two things will happen:

- The WAAS Central Manager will auto-assign the device to device groups (that are so marked). If any of these device groups have Akamai Connect/HTTP cache settings, the WAAS Central Manager will trigger registration with Akamai.

- If no device group is configured with Akamai Connect/HTTP cache settings, the registration is done individually.

After the device is registered, it will get a new entitlement key.

Replacing an Inactive or Expired Akamai Connect License

If your license has become inactive or expired, follow these steps to replace your license:

-
- Step 1** When a license is inactive or expired, a notification is displayed in one of two WAAS Central Manager screens:
- At the **Home > Admin > Licenses > Akamai Connect** screen: “Akamai Connect License is Inactive. Please remove current license and import valid license.”
 - At the **Home > Monitor > Troubleshoot > Akamai Diagnostics** screen: “Akamai Connect License is Inactive. Please remove existing license and import new one using Akamai License page.”
- Step 2** Remove the inactive or expired license.
- Step 3** To upload a new license file, at the **Home > Admin > Licenses > Akamai Connect** screen, click Choose File to browse to the new license file and click **Upload**.
- Step 4** If you import an expired license, you will see the message: “Unable to communicate to Akamai server (Error: License is inactive or expired). See Central Manager log file for detailed error information.”
- Step 5** To obtain a new license, contact your Cisco account representative or reseller.
-

Enabling Akamai Connected Cache

This section contains the following topics:

- [About Akamai Connected Cache](#)
- [Akamai Connected Cache Requirements](#)
- [Procedure for Enabling Akamai Connected Cache](#)

About Akamai Connected Cache

Akamai Connected Cache ([Figure 13-3](#)) allows the Cache Engine to cache content that is delivered by an Edge server on the Akamai Intelligent Platform. This is content that is served by the worldwide Akamai Content Delivery Network (CDN); it is typically not cacheable by enterprise cache engines, but can be cached in Akamai Cache Engine based on interactions with network edge elements that are serving it.

Figure 13-3 Akamai Connected Cache

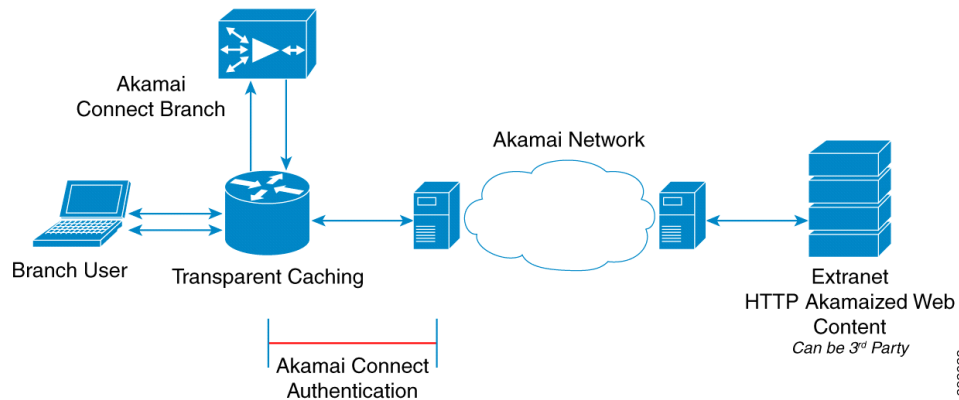

Akamai Connected Cache provides the following features:

- Object caching is done on the client-side WAAS device only.
- Prepositioning can be leveraged to cache HTTP websites delivered via the Akamai Intelligent Platform.
- During the enabling/registration of HTTP object cache, each WAE Cache Engine contacts the Akamai network to obtain credentials.
- The WAAS/Akamai Cache Engine determines which sites can be “Akamaized” by Akamai Connected Cache from the HTTP headers in the first reply. The Cache Engine and the Akamai Edge Server then exchange credentials and agree that Akamai Connected Cache can occur. This is done again via HTTP headers in HTTP request and responses.
- The Akamai Edge Servers can provide objects it is handling, the object that will not change, to allow WAEs with Akamai Cache Engine and the correct credentials to cache these objects. Users or other caches without valid credentials will not be allowed to cache.
- The Akamai Edge Server provides additional headers to allow the WAAS/Akamai Cache Engine to cache the objects for the objects it handles. The Cache Engine forwards this back to the corresponding client. The headers passed between the Cache Engine and the client are similar to what the client or enterprise proxy server would see if the WAE was not in the path.

Akamai Connected Cache Requirements

Akamai Connected Cache is enabled by default when you check the **Enable Akamai Connect** check box at the Akamai Connect **Cache Settings** tab (**Configure > Caching > Akamai Connect**).

Akamai Connected Cache requires registration and an authentication key to operate. For how to disable/enable Akamai Connected Cache see [Procedure for Enabling OTT Caching](#).

Procedure for Enabling Akamai Connected Cache

You can configure the Akamai Connected Cache - Cache Engine settings at the **device group level** (to apply a configuration to all registered devices) or the **device level** (to apply a configuration to a particular registered device).

To enable Akamai Connected Cache, follow these steps. For more information on Akamai Connected Cache, see [About Akamai Connected Cache](#).

-
- Step 1** To enable Akamai caching, check the **Akamai Connected Cache** check box. The default is enabled. When you enable Akamai connected cache, it is enabled for all suitable Akamaized content.
- Step 2** Click **Submit**.
- Step 3** After you enable Akamai Connected Cache, you can set a caching policy for all sites, or an individual caching policy for specific sites, as described in [Setting Caching Policies](#).
- Step 4** After you enable Akamai Connected Cache, you can configure cache repositioning, as described in [Configuring Cache Repositioning for Akamai Connect](#).
-

Enabling OTT Caching

This section contains the following topics:

- [Overview of OTT Caching](#)
- [Procedure for Enabling OTT Caching](#)

Overview of OTT Caching

This section contains the following topics

- [About OTT Caching](#)
- [Sites That Support OTT Caching](#)
- [Workflow for OTT Caching with WAAS and Akamai Connect](#)

About OTT Caching

Over the Top (OTT) caching caches dynamic content by examining the URL related to a session and a site to determine if the object is identical to the one previously stored in the Cache Engine cache. OTT is used for streamed content, particularly video content, and for sites that use dynamic URLs based on session or authentication methods. [Figure 13-4](#) shows an example of OTT caching.

OTT is a caching feature that Akamai has engineered to allow WAAS to cache and serve some popular sites that are normally not cacheable. This caching feature requires special metadata that is created and distributed by Akamai. OTT uses metadata logic to determine a unique cache key per video; this allows dynamic URLs to be cached.



Note

OTT is disabled by default, but enabled after HTTP application accelerator object cache is enabled. For how to enable or disable OTT, see [Procedure for Enabling OTT Caching](#).

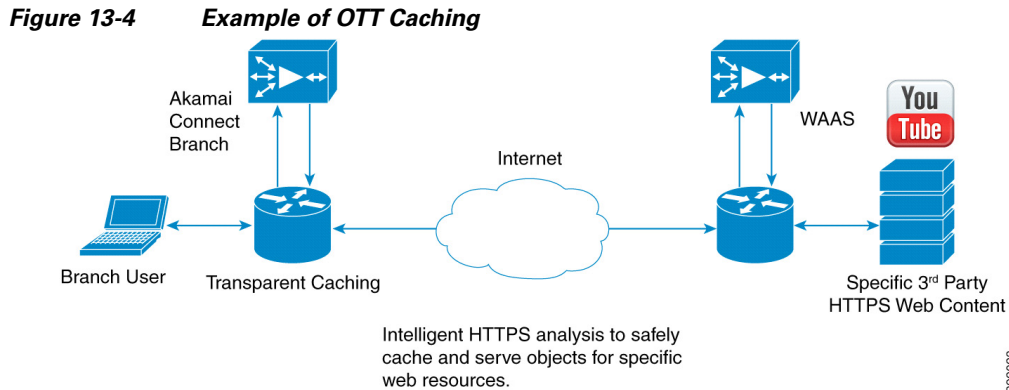

Sites That Support OTT Caching

Sites that support OTT caching include the following:

- Apple
- Google
- Lynda
- Microsoft Updates
- Office 365
- Pearson
- Salesforce
- Schoology
- Vimeo
- Youku
- YouTube
 - Since YouTube is delivered via HTTPS, you need to follow the same process as you do for SAAS optimization. For more information, see *Configuring SSL Acceleration for SaaS Applications* in Chapter 12, “Configuring Application Acceleration.” The domains that must be matched are *.youtube.com, *.yimg.com, *.googlevideo.com, and *.ggpht.com.

Workflow for OTT Caching with WAAS and Akamai Connect

The following is a workflow for OTT caching with WAAS and Akamai Connect for YouTube:

1. During the registration process the WAE Cache Engine provides metadata for YouTube.
2. A client goes to the YouTube site. (Note that the one client request actually requests the video in chunks, even with a dynamic ID. Each chunk not only contains a part of a video, but has an associated audio/video quality, such as 360p, 480p, or 720p.
3. The Akamai Cache Engine uses metadata logic to determine a unique cache key per dynamic ID. The Cache Engine stores this for one day, even though YouTube usually expires the dynamic ID in approximately six hours.
4. Each time the video is played, the request reaches out to the origin server and fetches the dynamic ID. It then compares this with the dynamic ID and cache key pair in the cache.

If the dynamic ID associated with the video has changed, the video will be served from the origin, and this will result in a miss. A new cache key is generated for that ID and is then stored.

If a match is found, the video is served out of cache.

Procedure for Enabling OTT Caching

To enable OTT caching, follow these steps.

-
- Step 1** To enable Over the Top (OTT) caching, check the **Over the Top Cache** check box. In the initial release, OTT caching applies only to YouTube.
- Step 2** Click **Submit** or continue to Advanced Cache Settings. For more information on Advanced Cache Settings, see [Advanced Mode](#).
-

Caching Types and Setting Caching Policies

This section contains the following topics:

- [Transparent Caching](#)
- [Order of Preference for Caching Types](#)
- [Setting Caching Policies](#)



Note

For Cisco WAAS with Akamai Connect, the terms Mode, Profile, and Policy are defined as follows:

Mode—The version of transparent caching (Basic, Standard, Advanced, or Bypass)

Profile—The set of host rules and caching types applied as a group, and which follows the Cache Engine order of precedence.

Policy—The set of rules and the conditions of caching, applied either individually or as a group, to a device or device group.

Transparent Caching

This section contains the following topics:

- [Overview of Transparent Caching](#)
- [Four Modes of Transparent Caching](#)

Overview of Transparent Caching

Transparent caching (which conforms to the RFC-2616 standard) delivers content from an origin server to the client without any modification. Transparent caching sends a request from a client to a server along with the associated authentication. No changes are made by proxy servers to either the headers or the returned packets along the way, although there are some headers that mark proxy actions that can be altered without the meaning of the cache control headers being altered.

There are four types of transparent caching modes: Basic, Standard, Advanced, and Bypass.

There are two modes in which transparent caching can operate: single-sided mode and dual-sided mode.



Note

When accessing transparent caching via HTTPS, the default caching mode is Basic mode. This ensures that no sensitive content is accidentally cached (in Basic mode, only content that you explicitly mark is cached). If you want content cached in a different mode with HTTPS, create a host rule that matches the HTTPS server location. For more information on creating a host rule, see [Setting Caching Policies](#).

Four Modes of Transparent Caching

This section describes the four modes for Transparent caching, as shown in [Table 13-5](#).

Table 13-5 *Transparent Caching: Overview of Caching Modes*

Caching Mode	Description
Basic Mode	Caches only the objects marked explicitly as cacheable.
Standard Mode (Default)	Caches objects marked as cacheable, and objects with no explicit cache marker and with a last-modified date. Ignores “reload” headers from clients.
Advanced Mode	Caches media types more aggressively, and caches all object types for longer times, when there is no explicit expiration time.
Bypass Mode	Turns off caching for a configured site or sites.

Basic Mode

In Basic mode, the Cache Engine works in strict RFC-2616 behavior, and therefore, only caches responses that are marked explicitly as cacheable with Cache-Control Headers or that have an Expire header - to service and accelerate traffic from a datacenter to a branch office over any type of IP network. Caching is only in the branch or local router, and content can be cached from the Internet regardless of the location of the original source.

Standard Mode (Default)

In Standard mode (default), the Cache Engine also follows RFC-2616 behavior for cache control headers, but with the following differences from Basic mode:

- In Standard mode, the Cache Engine does not honor client cache override behavior, for example, must-revalidate and proxy-revalidate.

- If cache-control or expire headers are not present, and Last Modified Time appears, the Cache Engine performs a heuristic based on the Last Modified Time and stores objects for 10 percent of their apparent age, up to a maximum of one day.

**Caution**

A properly configured website will work with Standard mode, but login pages, cookie setting pages, or dynamic content not properly marked as cacheable may break. We recommend that you test the website; this is especially important for a newly-created website or one that does not have many users.

Advanced Mode

In Advanced mode, the Cache Engine caches media types more aggressively, and caches all object types for longer times (when there is no explicit expiration time). Most of the benefits of Advanced mode over Standard mode occur if the website has not already marked cacheable media content properly. Advanced mode is best suited for media-rich Intranet sites.

If cache-control or expire headers are not present and Last Modified Time appears, the Cache Engine performs a heuristic based on the Last Modified Time and stores objects for 20 percent of their apparent age, up to a maximum of one day.

For certain media file types, listed in [Table 13-6](#), Advanced Mode will cache these for a full day if the media type is not specified as uncacheable or the media type has no obvious age in the request. For all other media types, the system caches the object for a minimum of one hour to a maximum of seven days - regardless of whether the Last Modified Time is present.

Table 13-6 *Advanced Mode: Media types that may be cached for a full day*

Advanced Mode: Media types that may be cached for a full day

(if not specified as uncacheable or has no obvious age in the request)

3g2	3gp	aac	aif	aiff	asf	asx	au	avi	bin	bmp
cab	carb	cct	cdf	class	css	dcr	doc	docx	dtd	dv
dvd	dvr	dvr-ms	exe	flv	gcf	gff	gif	grv	hdml	hqx
ico	ini	jpeg	jpg	js	m1v	m4a	midi	mov	mp3	mp4
mpeg	mpg	mpv	nv	pct	pdf	png	ppc	ppt	pptx	pws
qt	swa	swf	tif	txt	vbs	w32	wav	wbmp	wma	wml
wmlc	wmls	wmlsc	wmv	xsd	xsl	xls	xlsx	zip		

**Caution**

A properly configured website will work in Advanced mode, but Advanced mode may break the presentation of certain web pages if there are even minor caching misconfigurations. We recommend that you test the performance of this caching mode for your applications before you bring the Cache Engine into production. When testing, pay particular attention to dynamic URLs and to content that requires authentication to be presented to a client.

Bypass Mode

In Bypass mode, the Cache Engine turns off caching for one or more configured sites. When Transparent Bypass mode is set for a particular hostname, the caching for the hostname specified in a rule is suppressed.

Bypass mode is useful when you want to turn off Akamai Connected Cache or OTT caching for a site or for a part of a site.

For example, if you have servers of the type `images#.bar.com`, you can configure a bypass rule so that only `images2.bar.com` is excluded from caching. All other `images#.bar.com` servers will continue to be cached under the existing rules.

Order of Preference for Caching Types

When there are multiple caching modes and policies in use, the Cache Engine applies an order of precedence in the execution of these. A rule that is higher in the order of precedence is executed first, and any other rules that are applied to that domain or digital property is ignored. The order of precedence is:

1. Transparent caching rules
2. OTT/Akamai Connected Cache
3. Default Transparent policy

For example, if `test.com` is an Akamai Connected Cache property, but an Advanced mode cache rule is set for this site, then Advanced mode will take precedence and Akamai Connected Cache will be skipped.



Note

When cache prepositioning is turned on, it has the same priority as any other caching type.



Note

Akamai Connect determines cache type based on most exact hostname match followed by cache priorities. `www.host.com` is more exact than `*.host.com`. In this scenario, if a lower-priority cache, such as Akamai Connected Cache (Order of Precedence #2), has a more exact match than a higher priority cache, such as transparent (Order of Precedence #1), the caching will occur with the more exact match and lower-priority cache.

Setting Caching Policies

For how to set one caching policy for all sites, or how to set individual caching policies for a specific site, follow these steps:

-
- Step 1** From Devices or Device Groups, navigate to **Configure > Caching > Akamai Connect**.
 - Step 2** Choose the **Cache Settings** tab.
 - Step 3** In the **Advanced Cache Settings** section, at the **Default Transparent Caching Policy** drop-down list, choose a caching policy:
 - Basic
 - Standard (default)
 - Advanced
 - Bypass
 - Step 4** *To set a default caching policy for all sites, choose a caching policy and click **Submit**. To enable transparent caching for a specific site, see Step 5.*

- Step 5** To enable transparent caching for a specific site, change the **Default Transparent Caching Policy** to **Bypass**.
- Step 6** At the **Site Specific Transparent Caching Policy** section, click **Add Hostname/IP**. The **Site Caching Policy Task** dialog box opens.

- a. In the **Hostname/IP** field, specify the hostname of the site to be configured. The hostname can be a specific server, or a domain name that contains a wildcard, such as *.cisco.com.



Note When you configure **Bypass mode** as the site-specific transparent caching policy, you *must* specify a complete server name or complete (FQDN) domain name. If you use a wildcard to specify sites for Bypass mode, the sites will still be optimized via Akamai Cache.

- b. At the **Transparent Caching Policy** drop-down list, select the cache policy for this site: Basic, Standard, Advanced, or Bypass.
- c. Click **OK**. The new hostname/IP is added as a line item to the Site Specific Transparent Caching Policy table.



Note The policy you set for a specific site takes precedence over the default caching policy set for all sites.

You can configure up to 512 hostnames for each site-specific transparent caching policy.

- Step 7** Configure Cisco Cloud Web Security (CWS) user policy. For more information see [Cisco Cloud Web Security and Force IMS Features](#).
- Step 8** Configure HTTP Proxy:
- To configure WAAS Central Manager as HTTP proxy, see [Using the WAAS Central Manager as HTTP Proxy](#)
 - To configure external HTTP proxy, see [Configuring External HTTP Proxy](#).
-

Using HTTP Proxy for Connections to the Akamai Network

This section contains the following topics:

- [Overview of HTTP Proxy Connections to the Akamai Network](#)
- [Using the WAAS Central Manager as HTTP Proxy](#)
- [Configuring External HTTP Proxy](#)

Overview of HTTP Proxy Connections to the Akamai Network

When using Akamai Connect, the WAAS Central Manager and WAAS device(s) must be able to communicate with the Akamai Network: with the Akamai Luna API servers to provision entries for WAAS devices, and with the Akamai AMG devices for Akamai Connected Cache and OTT features.

However, some WAAS deployments may disallow outgoing connections to the Internet for the WAAS Central Manager or WAAS device(s). For these deployments, the WAAS device(s) may use an HTTP proxy to contact the Akamai Network.

You can set up the following proxy configurations:

- No HTTP proxy use
- [Using the WAAS Central Manager as HTTP Proxy](#)
- [Configuring External HTTP Proxy](#)

For these three proxy configurations, WAAS supports five deployment scenarios:

Deployment Scenario	Deployment Connections	WAAS Central Manager to Luna API Servers	WAAS HTTP Cache Engine to Akamai AMG
No HTTP proxy use	Direct/ Direct	Direct	Direct
WAAS Central Manager as HTTP proxy	Direct/ WAAS Central Manager as proxy	Direct	WAAS Central Manager as HTTP proxy
External HTTP proxy	Direct/ External HTTP proxy	Direct	External HTTP proxy
External HTTP proxy	External HTTP proxy/ Direct	External HTTP proxy	Direct
External HTTP proxy	External HTTP proxy/ External HTTP proxy	External HTTP proxy	External HTTP proxy

The following considerations apply to all HTTP proxy deployments:

- You configure HTTP proxy from the WAAS Central Manager; there are no CLI commands for HTTP proxy. Configuring HTTP proxy settings does not require restart of the WAAS Central Manager.
- HTTP Proxy must support HTTP Connect method for tunneling HTTPS connections.
- Configuring the HTTP proxy setting does not require restart of the WAAS Central Manager.



Note

WAAS v5.5.1 does not support HTTP proxy user authentication. It is recommended that you restrict access to proxy using IP address ACLs.

Using the WAAS Central Manager as HTTP Proxy

Note the following considerations when using the WAAS Central Manager as a proxy to the Akamai network:

- When using Akamai Connected Cache, each WAAS Cache Engine device is communicating with the Akamai network. Some WAAS deployments may disallow WAE devices to establish outgoing connections to the Internet (i.e., private networks). In this case, the WAE device may use the WAAS Central Manager device(s) as proxy for all connections to the Akamai network.
- You may still have to allow a hole for the WAAS Central Manager to make communications on TCP port 443 outbound.
- There is no option for the WAAS Central Manager to use a proxy device to get to the Internet.
- All connections are made from the WAAS Cache Engine device or WAAS Central Manager out to the Akamai network; never from the Akamai network to the WAAS Cache Engine device or WAAS Central Manager.
- You configure this feature from the WAAS Central Manager only, not the CLI.

To use the WAAS Central Manager as HTTP proxy, follow these steps:

-
- Step 1** From Devices or Device Groups, navigate to **Configure > Caching > Akamai Connect**.
 - Step 2** Choose the **Cache Settings** tab.
 - Step 3** Check the **Use HTTP proxy for connections to Akamai network** check box.
 - Step 4** At the **HTTP Proxy:** dropdown list, select **Central Manager as HTTP Proxy**.
 - Step 5** Click **Submit**.

Configuring External HTTP Proxy

When using the Akamai Connected Cache, WAAS devices are communicating with the Akamai Network. Some deployments may disallow outgoing connections to the Internet for WAAS devices. For these deployments, WAAS devices can use an HTTP proxy to contact the Akamai Network. For more information on HTTP proxy, see [Using HTTP Proxy for Connections to the Akamai Network](#).



Note HTTP proxy must support HTTP CONNECT for tunneling HTTPS connections.

To configure external HTTP proxy, follow these steps:

-
- Step 1** From Devices or Device Groups, navigate to **Configure > Caching > Akamai Connect**.
 - Step 2** Check the **Use HTTP proxy for connections to Akamai network** check box.
 - Step 3** At the **HTTP Proxy:** dropdown list, select **External HTTP Proxy**.
 - Step 4** Specify a Proxy Host and a Proxy Port:
 - **Proxy Host** field - Enter a hostname or address.
 - **Proxy Port** field- Enter a value between 1-65535.



Note If the WAAS Central Manager is already using an external HTTP proxy, there is no option displayed to use the WAAS Central Manager as proxy; these fields will display the currently configured HTTP proxy.

- Step 5** Click **Submit**.
-

Cisco Cloud Web Security and Force IMS Features

The Cisco Cloud Web Security (CWS) feature provides content scanning of HTTP and secure HTTP/S traffic and malware protection service to web traffic. CWS servers scan web traffic content and either allow or block the traffic based on configured policies. Servers use credentials such as private IP addresses, user names, and user groups to identify and authenticate users and redirect the traffic for content scanning.

Traffic is transparently proxied by an ASA or ISR to cloud-based CWS servers (called towers), where the web traffic is scanned and if deemed acceptable is provided to the origin server. All traffic coming back is through the CWS tower.

**Note**

For WAAS Version 6.2.1 and later, the CWS feature enforces content filtering by enabling force IMS (If Modified Since) for every cached object, for both single-sided and dual-sided deployment.

For WAAS Versions earlier than 6.2.1, content filtering is enforced on single-sided deployments.

Note the following considerations when using the Cisco CWS and option:

- CWS can be used only when one WAAS device is present in the path.
- When you enable CWS, the Akamai Cache Engine always adds an “if modified since” header to the request so that the response needs to go remote to the origin server (in this case, the Scansafe tower) - so all requests get scanned and no security is bypassed. If a 304 Not Modified is returned, then the Akamai Cache Engine provides the object from the cache. If a 200 Okay is returned, then the object is fetched from the origin server.
- If preposition is enabled and is possible that the flow may be redirected to a CWS tower, follow these recommendations:
 - (Preferred choice) configure a white-list on the ISR or CWS tower to bypass the WAE IP address.
 - On the CWS tower, configure a user or group that the WAE will fall into for authentication and allow it access to all sites on which the preposition is occurring.

To enforce the Cisco CWS user policy, follow these steps:

-
- Step 1** Navigate to **Configure > Caching > Akamai Connect > Cache Settings** tab.
 - Step 2** At the Advanced Settings section, check the **Force IMS DIA** check box to enable CWS user policy enforcement for content access in case of DIA.
 - Step 3** At the Advanced Settings section, check the **Force IMS Always** check box to apply CWS user policy enforcement for content access in case of all flows.
 - Step 4** Click **Submit**.
-

Configuring Cache Prepositioning for Akamai Connect

This section contains the following topics:

- [Overview of HTTP Proxy Connections to the Akamai Network](#)
- [Configuring a Cache Preposition Task](#)
- [Viewing Cache Prepositioning Task Status](#)
- [Copying Cache Prepositioning Tasks](#)

Overview of Cache Prepositioning for Akamai Connect

Cache prepositioning, also known as cache warming, allows you to specify a policy to prefetch and cache content at a specified time. For example, prepositioning content with a URL inside the branch office during non-peak hours can help to improve performance during peak hours, by significantly offloading WAN links.

Cache prepositioning runs at the same priority as other caching types, for example, Akamai Connected Cache or OTT.

For WAAS Version 6.2.1 and later with Akamai Connect, cache prepositioning for Akamai Connect also provides the following cache prepositioning features:

- Processing of manifest files for the video streaming protocols HLS (HTTP Live Streaming) and HDS (HTTP Dynamic Streaming).
- Prepositioning of JNLP (Java Network Launch Protocol) files, which contain URL reference for Java Web Start.

**Note**

In order for HTTPS content to be prepositioned, you must define an SSL accelerated service; otherwise, any HTTP requests encountered in the job will fail, although the preposition task will continue and any objects available via HTTP will be retrieved. For more information on how to define an SSL accelerated service, see *Configuring SSL Acceleration* in Chapter 12, “Configuring Application Acceleration.”

When a scheduled fetch operation begins or is complete, it is added to the Cache Preposition Status table.

Configuring a Cache Preposition Task

A cache preposition task contains elements that are configured in the following sections of the Cache Prepositioning tab:

- Cache Prepositioning Task dialog box—Specify the preposition task name, base URLs for prepositioning, include/exclude types, download rate, recursion depth, and task duration.
- Cache Prepositioning Task dialog box Advanced Settings—Specify the recursion delay time and recursion domains.
- Cache Prepositioning Schedule dialog box—Specify the schedule name for the preposition task, frequency of the task (such as daily or monthly), and start time.

To configure a cache preposition task, follow these steps:

- Step 1** From Devices or Device Groups, navigate to **Configure > Caching > Akamai Connect**.
The Akamai Connect window appears with two tabs: Cache Settings and Cache Prepositioning.
- Step 2** Choose the **Cache Prepositioning** tab. At this tab, you can add, edit, or delete cache prepositioning tasks, as well as monitor cache preposition task status.
- Step 3** (Optional) Check the **Preposition with DRE** check box to enable DRE for preposition connections. The default is disabled, to prevent negative impact to the DRE byte cache for data that will be stored at the object level.
- Step 4** Click **Add Cache Preposition Task**.
The Cache Prepositioning Task dialog box opens.
- Step 5** Enter values in the Cache Prepositioning Task dialog box fields, shown in [Table 13-7](#).

Table 13-7 Cache Prepositioning Task Dialog Box Fields

Field	Description
Name	<p>The name of the preposition task. Preposition task name is an alphanumeric identifier up to 47 characters. Special characters like ‘,/ \, {, }, (,), ?, ”, <, >, [,], &, *,” are not allowed.</p> <p>Note the following when specifying a task:</p> <ul style="list-style-type: none"> • You can configure up to 10 URLs per task. • You can configure up to 10 schedules per task. • You can configure up to 50 tasks per device or device group.
URLs	<p>The base URLs for prepositioning. The maximum length for the URL is 900 characters. Characters that are not allowed in the URL are space, double quotes (“”). ASCII characters are allowed in the range of ASCII 33 through ASCII 125.</p> <ul style="list-style-type: none"> • Use a space to separate multiple URLs. • You can configure up to 10 URLs per task.
Include Types	The object types to include in caching, such as .jsp or .asp, each separated by a comma. The list of object name patterns to be included has a total pattern field limit of 47 characters.
Exclude Types	The object types to exclude from caching, such as .jsp or .asp, each separated by a comma. The list of object name patterns to be excluded has a total pattern field limit of 47 characters.
Download Rate	The maximum download rate, in KBps. Select any value between 0 to 10,000,000 KBps. The default is 20 KBps. A selection of 0 indicates unlimited, or no enforced rate limiting.
Recursion Depth	<p>The depth of the link level at which the content is retrieved. Recursion depth is active only if you check the Recursive Task check box. Select 1, 2, 3, 5, 8, 13, or 21 from the drop-down list, or enter any custom value between 1 to 1000. The default is 1.</p> <p> Note A greater number of specified levels of links means a greater amount of data stored in the cache, sometimes exponentially more. If the amount of requested prefetched data becomes larger than the cache, the newly requested data will flush all previously stored data, and may slow down other operations that attempt to use the cache.</p>
Duration	<p>The maximum amount of time, in minutes, a preposition task can run before it is halted. The default is no set duration. To set a duration time, select from a range of 1 to 2,147,483,647 minutes.</p> <p>Setting the duration of a task is especially useful to:</p> <ul style="list-style-type: none"> • Ensure that preposition tasks do not overlap with each other. • Ensure that preposition tasks do not overlap with times of higher user traffic.

Field	Description
User Agent	<p>Provides information on browser and operating system type that servers use to identify and respond to. The server populates the cache with content that is dependent in part on the type of user agent used for this cache prepositioning task.</p> <p>Enter browser and operating system information, in an alphanumeric string, up to a maximum of 256 characters.</p> <p>You can also use the user-agent <i>useragent-name</i> global configuration command to configure the user agent string</p>
Enable Task	<p>Check the Enable Task check box to enable the specified preposition task to run. For the task to run, you must specify at least one URL and one schedule (described in Step 5).</p>
Enable Proxy	<p>For WAAS Version 6.2.1 and later, you can configure a HTTP/S proxy support for preposition tasks.</p> <p>Check the Enable Proxy check box to configure external proxy for this preposition task. For details on configuring external proxy for a preposition task, see Configuring HTTP/S Preposition Proxy for Akamai Connect.</p>

Step 6 At the **Advanced Settings** section of the **Cache Prepositioning Task** dialog box, you can specify recursion delay time and recursion hostnames:

Field	Description
Recursion Delay Time	<p>The delay time, in seconds, between requests during recursive download. This simulates user wait time. Recursive delay time is necessary because some servers use the lack of time between requests to detect and restrict web spiders.</p> <ul style="list-style-type: none"> • Enter a value between 0 to 600 seconds. The default is 2 seconds. • A value of zero provides the best performance when there are no web spider restrictions.
Recursion Domains	<p>The list of server domain suffixes for which recursive spidering is permitted. If the list is empty, then spidering is only permitted within the same domain as the specified URL.</p> <p>You can configure up to ten servers:</p> <ul style="list-style-type: none"> • The server name is up to 255 characters. • Server names are separated by comma or space.

Step 7 In the **Cache Prepositioning Schedule** section, click **Add Schedule**.
The Cache Prepositioning Schedule dialog box opens

Step 8 Specify the following:

Field	Description
Schedule Name	The name of the schedule for this preposition task. Schedule name is an alphanumeric identifier up to 256 characters. The Schedule Name allows you to provide your own representation of a schedule. For example, for a schedule that occurs each Monday, Wednesday, and Friday at 10:30 a.m. can be named as Weekly MWF 10:30AM or Every Week - MON-WED-FRI at 10:30AM .
Frequency	The specified time for prepositioning: yearly, daily, weekly, or monthly days. If you choose monthly days, a calendar with check boxes opens for you to check one, some, or all the days in a month for this schedule.
Start Time (HH:MM)	From the two drop-down lists, choose the hour and minute at which the task schedule should start.

Step 9 In the Cache Prepositioning Schedule dialog box, click **OK**.

Step 10 In the Cache Prepositioning Task dialog box, click **OK**.

Step 11 Click **Submit**.

The new cache prepositioning task is added as a line item to the Cache Prepositioning listing table.

Viewing Cache Prepositioning Task Status

Two tables are provided in the Cache Prepositioning section to show the status of a cache prepositioning task. To view the status of a cache preposition task you have configured, select the task from the first table, the Cache Preposition Listing table. The second table, the Cache Prepositioning Status table, displays information on the selected task.

- *For an individual device*, the cache prepositioning status table shows the selected task status for the current device.
- *For a device group*, the cache prepositioning status table shows the status of the selected cache preposition task, for all devices under that device group.

The following types of information are displayed for the selected task:

Field	Description
Device Name	The name of the selected device.
Start Time	The date, hour, and minute for the task schedule to start.
End Time	The date, hour, and minute for the task schedule to end.
Byte Count	The total number of bytes in cache during the most recent preposition task run.
Object Count	The total count of objects in cache during the most recent preposition task run.
Refresh Bytes	The number of bytes refreshed in cache during the most recent preposition task run.
Refresh Count	The count of objects refreshed in cache during the most recent preposition task run.
Store Bytes	The number of unmodified bytes for objects found in cache during the most recent task run.
Store Count	The count of unmodified objects found in cache during the most recent task run.

Field	Description
Uncacheable Bytes	The number of bytes of uncacheable objects encountered during the most recent task run.
Uncacheable Count	The count of uncacheable objects encountered during the most recent task run.
Status	The status of the task, such as Scheduled, Complete, or Error.
Error	If the task status is “Error,” an error message describing the task status is displayed.

Copying Cache Prepositioning Tasks

You can copy cache prepositioning tasks that have a device or device group enabled with Akamai Connect, with WAAS running v5.5.1 or 5.4.1. Use the following methods to copy cache prepositioning tasks:

- Device to device
- Device to device group
- Device group to device
- Device group to device group



Note

Cache Preposition Tasks and WAAS versions: You can also use the **Copy Tasks** feature to copy a cache preposition task between WAAS Version 5.5.1 devices and device groups and WAAS versions earlier than Version 5.5.1 devices and device groups.

To copy a cache preposition task, follow these steps:

Step 1 Navigate to **Configure > Caching > Akamai Connect > Cache Prepositioning** tab > **Cache Prepositioning** section.

Step 2 Click the **Copy Tasks** button.

The **Cache Prepositioning Task** dialog box opens.

Step 3 At the **From** drop-down list, select a device or device group as the source.

Step 4 At the next drop-down list, select a device or device group as the destination.



Note

If you try to copy a task with the same name between device and device groups, the following error message is displayed: **One or more preposition tasks with the same name already exists in the destination device/DG.**

Step 5 At the **Existing Cache Prepositioning Tasks** table, select one, some or all of the preposition tasks to be copied.

Step 6 Click **OK**.

The selected cache prepositioning tasks are copied from the source to the destination.

Configuring HTTP/S Preposition Proxy for Akamai Connect

This section contains the following topics:

- [Overview of HTTP/S Preposition Proxy for Akamai Connect](#)
- [Configuring Global Proxy Host and Port for Preposition Tasks](#)
- [Modifying Proxy Settings for an Individual Preposition Task](#)
- [Removing Proxy Settings for an Individual Preposition Task](#)

Overview of HTTP/S Preposition Proxy for Akamai Connect

For WAAS Version 6.2.1 and later, you can preposition external content in the case of a deployment with proxy. Consider the following when configuring HTTP/S preposition proxy for Akamai Connect:

- IPv4 proxy is supported for HTTP/S prepositioning.
- The HTTP preposition proxy feature is a feature independent of the WAAS Central Manager and external HTTP proxy features described in the sections [Using the WAAS Central Manager as HTTP Proxy](#) and [Configuring External HTTP Proxy](#).
- Specific IP address-based proxy configuration is supported for HTTP/S preposition proxy. File-based and auto-detected configurations are not supported for HTTP/S preposition proxy.

Configuring Global Proxy Host and Port for Preposition Tasks

To configure global proxy host and port for preposition tasks, follow these steps.

-
- Step 1** From the WAAS Central Manager menu, from either the Device Groups or Devices tab, choose **Configure > Caching > Akamai Connect**.
- The Akamai Connect window appears, with two tabs: Cache Settings and Cache Prepositioning.
- Step 2** Choose the **Cache Prepositioning** tab.
- Step 3** In the **Proxy Host** field, enter the hostname or IP address for the proxy host.
- Step 4** In the **Proxy Port** field, enter the port number. Valid port numbers are 0 to 65535.
- Step 5** Click **Submit**.
- Step 6** Create a preposition task, as described in [Configuring a Cache Preposition Task](#).
- Step 7** In the Cache Prepositioning Task dialog box, check the **Enable Proxy** check box.
- Step 8** Schedule the task, as described in Steps 7 through 9 of [Configuring a Cache Preposition Task](#).
- Step 9** Click **Submit**.
-

Modifying Proxy Settings for an Individual Preposition Task

To modify proxy settings for an individual preposition task, follow these steps.

-
- Step 1** From the WAAS Central Manager menu, from either the Device Groups or Devices tab, choose **Configure > Caching > Akamai Connect**.
- The Akamai Connect window appears, with two tabs: Cache Settings and Cache Prepositioning.
- Step 2** Choose the **Cache Prepositioning** tab.
- Step 3** Select a cache prepositioning task that you have configured as proxy.
- Step 4** Modify the particular setting or settings.
- Step 5** Check the **Enable Task** check box.
- Step 6** Check the **Enable Proxy** check box.
- Step 7** In the **Cache Prepositioning Schedule** dialog box, select parameters to reschedule the task.
- Step 8** Click **OK**.
- Step 9** In the **Cache Prepositioning Task** dialog box, click **OK**.
- Step 10** Click **Submit**.
-

Removing Proxy Settings for an Individual Preposition Task

To remove proxy settings for an individual preposition task, follow these steps.

-
- Step 1** From the WAAS Central Manager menu, from either the Device Groups or Devices tab, choose **Configure > Caching > Akamai Connect**.
- The Akamai Connect window appears, with two tabs: Cache Settings and Cache Prepositioning.
- Step 2** Choose the **Cache Prepositioning** tab.
- Step 3** Select a cache prepositioning task that you have configured as proxy.
- Step 4** Check the **Enable Task** check box.
- Step 5** Uncheck the **Enable Proxy** check box.
- Step 6** In the **Cache Prepositioning Schedule** dialog box, select parameters to reschedule the task.
- Step 7** Click **OK**.
- Step 8** In the **Cache Prepositioning Task** dialog box, click **OK**.
- Step 9** Click **Submit**.
-

Cisco Support for Microsoft Windows Update

Cisco support for Microsoft Windows Update enables caching of objects used in Windows OS and application updates. Cisco support for Microsoft Windows Update is enabled by default, and enabled only for specific sites.

This section contains the following topics:

- [Benefits of Cisco Support for Microsoft Windows Update](#)

- [Viewing Statistics for Cisco Support for Microsoft Windows Update](#)
- [Cisco Support for Microsoft Windows Update and Akamai Cache Engine](#)

Benefits of Cisco Support for Microsoft Windows Update

The Microsoft OS and application updates are managed by update clients such as Microsoft Update. Microsoft Update downloads the updates via HTTP, often in combination with BITS (Background Intelligent Transfer Service) to help facilitate the downloads. Clients use HTTP range request to fetch updates.

The objects that comprise the updates, such as .cab files, are typically cacheable, so that HTTP object cache is a significant benefit for this process.

For example, for Windows 7 and 8 OS updates—via direct Internet or WSUS (Windows Server Update Services), versions 2012 and 2012R2—more than 98% of the update files, such as .cab, .exe, and .psf files, are served from cache on subsequent updates. Cisco support for Microsoft Windows Update reduces the volume of WAN offload bytes and reduces response time for subsequent Windows updates.

Viewing Statistics for Cisco Support for Microsoft Windows Update

There are two ways to view data generated by Cisco support for Microsoft Windows Update:

- [Akamai Connected Cache Charts](#) in Chapter 15, “Monitoring Your WAAS Network,” provides information including WAN response time and WAN offload bytes.
- For WAAS Version 6.1.1 and later, the cache engine access log file has two new fields for Microsoft Windows Update statistics:
 - rm-w (range miss, wait)—The main transaction, a cache miss, which waited for the sub-transaction to fetch the needed bytes.
 - rm-f (range miss, full)—The sub-transaction, a cache write of the entire document.

Example 1:

Example 1 contains two log lines, the main transaction and sub-transaction, when a range is requested on an object that is not in cache:

```
ws8-rt-kb2863725-x64_dd8522e527483cd69bf61d98ee849a2406b97172.psf - -
08/28/2015 12:22:29.663 (f1=27520) 300 13.164 0.000 446 - - 34912 172.25.30.4

191.234.4.50 2905 h - - rm-w 206 GET
http://fg.v4.download.windowsupdate.com/d/msdownload/update/software/secu/2013/07/wind
ows8-rt-kb2863725-x64_dd8522e527483cd69bf61d98ee849a2406b97172.psf - -

08/28/2015 12:24:31.448 (f1=27520) 300 134.949 0.000 355 344 3591542 568 172.25.30.4
191.234.4.50 2f25 m-s - - rm-f 200 GET
http://fg.v4.download.windowsupdate.com/d/msdownload/update/software/secu/2013/07/wind
ows8-rt-kb2863725-x64_dd8522e527483cd69bf61d98ee849a2406b97172.psf - -
```

Example 2:

Example 2 shows a cache hit when a range is requested on an object that is either completely in cache, or in the process of being downloaded. If it is in the process of being downloaded, then the main transaction has latched onto a sub-transaction like the one shown in Example 1.

```
08/28/2015 03:34:36.906 (fl=26032) 300 0.000 50.373 346 - - 13169 172.25.30.4
8.254.217.62 2905 h - - - 206 GET
http://fg.v4.download.windowsupdate.com/d/msdownload/update/software/secu/2013/07/wind
ows8-\ rt-kb2863725-x64_dd8522e527483cd69bf61d98ee849a2406b97172.psf - -
```

Cisco Support for Microsoft Windows Update and Akamai Cache Engine

Cisco support for Microsoft Windows Update enables Akamai Cache Engine to support Windows Update caching in two ways:

- Download and cache full objects even when ranges within objects that not in cache are requested.
- Future range requests on the objects can be served out of cache.

There is a limit, set by OTT metadata during the Akamai Connect registration process, from the start of the object—the number of bytes or the percent of file length—where the download functionality is triggered. A request of a size above the set limit does not initiate a full object download, and the request is forwarded to the origin as is.



Caution

Cisco Support for Microsoft Windows update is enabled by default, and enabled only for specific sites. The enabled sites are updated via OTT metadata.

If you want to disable Cisco Support for Microsoft Windows Update, you must disable OTT caching. To do this, uncheck the **Over the Top Cache** check box. However, note that unchecking the **Over the Top Cache** check box disables *all* OTT functionality, both global and custom OTT configurations.

For more information on the Akamai Connect registration process, see [Activating the Akamai Connect License](#).



PART 2

Maintaining, Monitoring, and Troubleshooting your Cisco WAAS Network



Maintaining Your WAAS System

This chapter describes the tasks that you should perform to maintain your WAAS system.



Note

Throughout this chapter, the term Cisco WAAS device is used to refer collectively to the Cisco WAAS Central Managers and Cisco Wide Area Application Engines (WAEs) in your network. The term WAE refers to WAE and WAVE appliances, Cisco Service-Ready Engine service modules (SRE-SM) running Cisco WAAS, and Cisco Virtual WAAS (vWAAS) instances.

This chapter contains the following sections:

- [Upgrading the WAAS Software](#)
- [Backing Up and Restoring Your WAAS System](#)
- [Performing Disk Maintenance for RAID-1 Systems](#)
- [Removing and Replacing Disks in RAID-5 Systems](#)
- [Configuring the Central Manager Role](#)
- [Enabling Disk Encryption](#)
- [Configuring a Disk Error-Handling Method](#)
- [Enabling Data Cache Management](#)
- [Activating All Inactive WAAS Devices](#)
- [Rebooting a Device or Device Group](#)
- [Performing a Controlled Shutdown](#)

Upgrading the WAAS Software

[Table 14-1](#) outlines the steps that you must complete to upgrade your WAAS software to the latest version.

We recommend that all the devices in your WAAS network run the same version of the WAAS software. If some of your WAAS devices are running different software versions, the WAAS Central Manager should be the latest version. For details on version interoperability limitations, see the [Release Note for Cisco Wide Area Application Services](#).

If the Central Manager sees any registered WAE devices that are at a higher version level than the current one, it raises a minor alarm to alert you. Additionally, the WAE devices are shown in red on the device listing page.

WAAS Central Manager Version 5.4.1 can manage WAE devices running Version 4.3.1 and later. Some WAAS Central Manager windows (with new features) are not applicable to WAAS devices that are running a version lower than 5.4.1. If you modify the configuration in such windows, the configuration is saved, but it has no effect on the device until the device is upgraded to Version 5.4.1.

**Note**

WAAS Version 5.4 is not supported running in a mixed-version WAAS network, where any WAAS device is running a software version lower than 4.3.1. If you have WAAS devices running versions earlier than 4.3.1, you must first upgrade them to Version 4.3.1 (or a later version) before you install version 5.2 on the Central Manager. Do not upgrade any device to a version later than the existing Central Manager version. After all the devices are upgraded to Version 4.3.1 or a later, you can begin the upgrade to Version 5.4.1 on the WAAS Central Manager. Directly upgrading a device from Version 4.0, 4.1 or 4.2 to 5.4.1 is not supported.

**Note**

When a SM-SRE device registered to a Central Manager (both running the same software version) is downgraded to a lower version, the SM-SRE device goes offline. You need to de-register the device from the Central Manager and reload it twice for the configuration to take effect. Next you need to register the device to the Central Manager for it to work properly.

Upgrading is supported only from certain older releases to a particular release. If you have a WAAS device that is running a release from which upgrading to the desired release is not supported, first upgrade the device to an intermediate supported release and then to the final desired release. For details on what versions are supported for upgrades, see the [Release Note for Cisco Wide Area Application Services](#) for the software version to which you want to upgrade.

**Note**

Before starting the upgrade, disable WCCP on all WAEs in an AppNav cluster. After upgrade is complete, confirm the following before you re-enable WCCP.

- The WAEs are up and running.
- The AppNav cluster is re-converged properly.
- All disks are ready (not initializing).
- No alarms on the device.
- The **show accelerator** command shows all enabled Application Optimizers are healthy.

After you have confirmed that each of these is complete, you can re-enable WCCP.

Table 14-1 Checklist for Upgrading the WAAS Software

Task	Additional Information and Instructions
1. Determine the current software version running on your WAAS network.	Check the software version that you are currently using so when you go to Cisco.com, you know if there is a newer version to download. For more information, see Determining the Current Software Version .

Table 14-1 Checklist for Upgrading the WAAS Software (continued)

Task	Additional Information and Instructions
2. Obtain the new WAAS software version from Cisco.com.	Visit Cisco.com to download a newer software version and place this file on a local FTP or HTTP server. For more information, see Obtaining the Latest Software Version from Cisco.com .
3. Register the new software version with the WAAS Central Manager.	Register the URL of the new software file so the WAAS Central Manager knows where to go to access the file. For more information, see Specifying the Location of the Software File in the WAAS Central Manager GUI .
4. Upgrade your WAAS Central Manager.	Upgrade the standby and primary WAAS Central Managers. For more information, see Upgrading the WAAS Central Manager .
5. Upgrade your WAAS devices using Device Groups.	After upgrading the WAAS Central Manager, upgrade all your WAAS devices that are members of a device group. For more information, see Upgrading Multiple Devices Using Device Groups .
6. Delete the software version file.	After completely upgrading your WAAS network, you can remove the software file if desired. For more information, see Deleting a Software File .

Installing a software version on a SM-SRE device from a router using IPv6 address is not supported.

To downgrade or roll back the WAAS software to a lower version, first downgrade or roll back the WAE devices' version, then the standby Central Manager (if applicable), and finally the primary Central Manager. For more information about downgrading, see the [Release Note for Cisco Wide Area Application Services](#).

Determining the Current Software Version

To view the current software version running on a particular device, choose **Devices > All Devices**. The All Devices window displays the software version for each listed device.

You can also click **Devices > device-name** or the **Edit** icon next to the name of a device in the Devices window. The Device Dashboard window appears, listing the software version for that device.



Note The software version is not upgraded until a software upgrade is successfully completed. If a software upgrade is in progress, the version number displayed is the base version, not the upgraded version number.

Alternatively, in the device context, choose **Monitor > CLI Commands > Show Commands**. Choose **version** and click **Submit**. A secondary window is displayed with the CLI output for the **show version** command.

Obtaining the Latest Software Version from Cisco.com

To obtain the latest WAAS software version from Cisco.com, follow these steps:

-
- Step 1** Launch your web browser and access the cisco.com website:
<http://www.cisco.com/cisco/software/navigator.html>
- Step 2** Navigate to the **Application Networking Services > Wide Area Application Services > Cisco Wide Area Application Services (WAAS) Software** download area.
- Step 3** Choose the WAAS software version that you want and download the appropriate software image.
- Step 4** Register the location of the software file in the WAAS Central Manager GUI, as described in [Specifying the Location of the Software File in the WAAS Central Manager GUI](#).
-

Specifying the Location of the Software File in the WAAS Central Manager GUI

To upgrade your WAAS software, you must first specify the location of the WAAS software file in the WAAS Central Manager GUI and configure the software file settings.

There are two types of WAAS software files:

- **Universal**—Includes Central Manager, Application Accelerator, and AppNav Controller functionality. You can use this type of software file to upgrade a device operating in any mode.
- **Accelerator only**—Includes Application Accelerator and AppNav Controller functionality only. You can use this type of software file to upgrade only an Application Accelerator or AppNav Controller device. If you want to change an Application Accelerator or AppNav Controller to a Central Manager, you must install the Universal software file, reload the device, change the device mode to central-manager, and then reload the device again. Additionally, kdump analysis functionality is not included in the Accelerator only image.

To configure the software file settings form, follow these steps:

-
- Step 1** From the WAAS Central Manager menu, choose **Admin > Version Management > Software Update**.
- Step 2** Click the **Create New Software File** icon in the taskbar.
The Creating New Software File window appears. (See [Figure 14-1](#).)

Figure 14-1 Creating New Software File Window

- Step 3** In the Software File URL field, specify the location of the new WAAS software file as follows:
- a. Choose a protocol (**http** or **ftp**) from the **Software File URL** drop-down list.
 - b. Enter the URL for the .bin software file that you downloaded from Cisco.com. For example, a valid URL might look like the following:

```
http://internal.mysite.com/waas/WAAS-xxxx-K9.bin
```

```
http://2012:3:3:3::8/waas/WAAS-xxxx-K9.bin
```

Here, WAAS-xxxx-K9.bin is the name of the software upgrade file. (The filename typically includes the version number.)

Be sure that the URL identifies the correct type of software image for the devices you want to upgrade, either Universal or Accelerator only.

If the Central Manager has been configured with an IPV6 address, it can be accessed using

```
https://[CM ipv6 address]:8443/
```

Software update configuration with IPV6 address will be filtered in the device /device group level usage pages for unsupported device models / versions.
- Step 4** (Optional) If your server requires user login authentication, enter your username in the **Username** field and enter your login password in the **Password** field. Enter the same password in the **Confirm Password** field.
- The **Software Version** and **Image Type** fields cannot be edited. They are filled in automatically after you submit the settings and the image is validated.
- Step 5** In the Advanced Settings section, check the **Auto Reload** check box to automatically reload a device when you upgrade the software. If you do not check this check box, you should manually reload a device after you upgrade the software on it to complete the upgrade process.
- Step 6** (Optional) Enter comments in the **Comments** field.
- Step 7** Click **Submit**.

The software image file is validated and the Software Version and Image Type fields are filled in with the appropriate information extracted from the image file.

**Caution**

If your browser is configured to save the username and password for the WAAS Central Manager GUI, the browser will autopopulate the **Username** and **Password** fields in the Creating New Software File window. You must clear these fields before you click **Submit**.

The software file that you want to use is now registered with the WAAS Central Manager. When you perform the software upgrade or downgrade, the URL that you just registered becomes one of the choices available in the Update Software window.

To reload a device from the CLI, use the **reload EXEC** command.

**Note**

When you are viewing the list of registered software files, if the Image Type column shows Unknown for a software file, it indicates that the software file was added under a WAAS version previous to 4.2.1. These Unknown software files must be resubmitted if you want to use them. Click the **Edit** icon next to the file to open the Modifying Software File window, and then click the **Submit** button to resubmit the file.

Upgrading the WAAS Central Manager

When upgrading software in your WAAS network, begin with WAAS Central Manager before upgrading the WAE devices.

Primary and standby WAAS Central Manager devices must be running the same version of WAAS software. If they are not, the standby WAAS Central Manager detects this and will not process any configuration updates it receives from the primary WAAS Central Manager. If the primary WAAS Central Manager sees that the standby WAAS Central Manager has a different version level, it shows the standby WAAS Central Manager in red on the device listing page.

If you use the primary WAAS Central Manager to perform the software upgrade, you need to upgrade your standby WAAS Central Manager first, and then upgrade your primary WAAS Central Manager. We also recommend that you create a database backup for the primary WAAS Central Manager and copy the database backup file to a safe place before you upgrade the software.

Use this upgrade procedure for WAAS Central Manager devices. You can also use this upgrade procedure to upgrade WAAS devices one at a time (after the WAAS Central Manager).

To upgrade your software to another WAAS software release on a single device, follow these steps:

-
- Step 1** From the WAAS Central Manager menu, choose **Devices > device-name**.
The Device Dashboard window appears.
 - Step 2** Verify that the device is not already running the version to which you plan to upgrade.
 - Step 3** Click the **Update** link.
The Software Update window appears.
 - Step 4** Choose the software file URL from the Software Files list by clicking the radio button next to the corresponding filename.

The list displays only software files with an image type of Universal, because you are upgrading a Central Manager device. If no such images are available, you must create a software file, as described in [Specifying the Location of the Software File in the WAAS Central Manager GUI](#).

Step 5 Click **Submit**, and then click **OK** to confirm your decision.

The Devices Listing window is displayed again. You can monitor the progress of your upgrade from this window.

Software upgrade status messages are displayed in the Software Version column. These intermediate messages are also written to the system log on the WAAS devices. See [Table 14-2](#) for a description of upgrade status messages.

Step 6 Clear your browser cache, close the browser, and restart the browser session to the WAAS Central Manager.

The WAAS Central Manager may reboot at the conclusion of the upgrade procedure (if **Auto Reload** is in the Creating New Software File window), causing you to temporarily lose contact with the device and the GUI.

Table 14-2 Upgrade Status Messages

Upgrade Status Message	Condition
Pending	The request is yet to be sent from the WAAS Central Manager to the device, or receipt of the request is yet to be acknowledged by the device.
Downloading	The download method for the software file is being determined.
Proceeding with Download	The download method for the software file is determined to be a direct download. Proceeding with the request for direct download of the software file.
Download in Progress (Completed ...)	The direct download of the software file is being processed. Completed indicates the number of megabytes processed.
Download Successful	The direct download of the software file is successful.
Download Failed	The direct download of the software file cannot be processed. Further troubleshooting is required; see the device system message log. If you are upgrading several devices at once, the download may fail if the server hosting the software file becomes overloaded with requests. Retry the upgrade by clicking the Retry link if it is displayed.
Proceeding with Flash Write	A request has been made to write the software file to the device flash memory.
Flash Write in Progress (Completed ...)	The write of the device flash memory is being processed. "Completed" indicates the number of megabytes processed.
Flash Write Successful	The flash write of the software file has been successful.
Reloading	A request to reload the device has been made in order to complete the software upgrade. The device may be offline for several minutes.
Reload Needed	A request to reload the device has not been made. The device must be reloaded manually to complete the software upgrade.

Table 14-2 Upgrade Status Messages (continued)

Upgrade Status Message	Condition
Cancelled	The software upgrade request was interrupted, or a previous software upgrade request was bypassed from the CLI.
Update Failed	The software upgrade could not be completed. Troubleshooting is required; see the device system message log. If you are upgrading several devices at once, the upgrade may fail if the server hosting the software file becomes overloaded with requests. Retry the upgrade by clicking the Retry link if it is displayed.

Upgrading Multiple Devices Using Device Groups



Note

This procedure is for WAE devices only. WAAS Central Manager devices cannot be upgraded using device groups.

To upgrade to a more recent WAAS software release on multiple devices, follow these steps:

-
- Step 1** From the WAAS Central Manager menu, choose **Device Groups** > *device-group-name*.
- Step 2** Choose **Admin** > **Versioning** > **Software Update**.
The Software Update for Device Group window appears.
- Step 3** Choose the software file URL from the Software File URL list by clicking the radio button next to the filename. If no images are available, create a software file, as described in [Specifying the Location of the Software File in the WAAS Central Manager GUI](#).
- If you are updating many devices and you want to use a smaller size software file to save network bandwidth, specify a software file with an image type of Accelerator only, which is smaller than a Universal image. If you later want to change an Accelerator-only device to a Central Manager, you must install the Universal software file, reload the device, change the device mode to central-manager, and then reload the device again.
- Step 4** Click **Submit**.
To view the progress of an upgrade, go to the All Devices window (**Devices** > **All Devices**) and view the software upgrade status message in the Software Version column. These intermediate messages are also written to the system log on WAAS devices. See [Table 14-2](#) for a description of the upgrade status messages.
-

Upgrading Central Manager to New Hardware and Converting an Existing Central Manager to a WAE

If you want to add a new piece of hardware as a primary Central Manager and want to use the existing Central Manager as a WAE, it is important to first add it to the system and then configure it.

**Note**

Performing a database backup of the former Central Manager and restoring it on the new device prevents it from being used as a WAE later.

To upgrade to a new Central Manager and convert an existing Central Manager to a WAE, follow these steps:

- Step 1** Add a hardware device as the new Central Manager and configure it as a standby Central Manager. There might be multiple standby Central Managers in the system. For more information, see [Configuring the Central Manager Role](#).
- Step 2** Enable the new hardware device to be the primary Central Manager after it is available online and has finished synchronizing with other systems. For more information, see [Converting a Standby Central Manager to a Primary Central Manager](#)
- Step 3** Disable CMS service and execute the **cms deregister** command at the former Central Manager CLI interface to remove it from the CM database. If there is no connectivity between the devices anymore, use the **cms deregister force** command and manually delete the former Central Manager in the new Central Manager GUI.

```
wae# cms deregister force
Deregistering WAE device from Central Manager will result in loss of data on encrypted
file systems, imported certificate/private keys for SSL service and wafs preposition
credentials. If secure store is initialized and open, clear secure store and wait for one
datafeed poll rate to retain wafs preposition credentials.
Do you really want to continue (yes|no) [no]?yes Disabling management service.
management services stopped
Sending de-registration request to CM
Failed to contact CM(Unmarshaled: 9001). Please check connectivity with CM device and
status of management service on CM.
Device de-regsitration failed, removing device registration information.
Please delete the device record on the Central Manager.
Removing cms database tables.
Re-initializing SSL managed store and restarting SSL accelerator.Deregistration complete.
Save current cli configuration using 'copy running-config startup-config' command because
CMS service has been disabled.
#
```

- Step 4** Rename the former Central Manager, change the IP address, change its mode using the **device mode** command, and reload using the **reload** command:

```
wae# configure
wae(config)# device mode application-accelerator
The new configuration will take effect after reload.
wae# reload
```

- Step 5** Rename the new primary Central Manager and change its IP address to fully replace the former one. Otherwise, you will need to update the configuration of your devices to point to the new address of the Central Manager. Contact a Cisco TAC member for scripts.

```
wae(config)# hostname old primary central-manager name
wae(config-if)# ip address ipaddress netmask.
```

Deleting a Software File

After you have successfully upgraded your WAAS devices, you can remove the software file from your WAAS system.

**Note**

You may want to wait a few days before removing a software file in the event that you may have to downgrade your system for any reason.

To delete a software file, follow these steps:

- Step 1** From the WAAS Central Manager menu, choose **Admin > Version Management > Software Update**.
- Step 2** Click the **Edit** icon next to the software file that you want to delete. The Modifying Software File window appears.
- Step 3** Click the **Trash** icon in the taskbar.
You are prompted to confirm your decision to delete the software file.
- Step 4** Click **OK**.
The selected software file is removed from the WAAS network.

Backing Up and Restoring Your WAAS System

This section contains the following topics:

- [Backing Up and Restoring the WAAS Central Manager Database](#)
- [Backing Up and Restoring a WAE Device](#)
- [Reinstalling the System Software](#)
- [Recovering the System Software](#)
- [Recovering a Lost Administrator Password](#)
- [Recovering from Missing Disk-Based Software](#)
- [Recovering WAAS Device Registration Information](#)

Backing Up and Restoring the WAAS Central Manager Database

The WAAS Central Manager device stores WAAS network-wide device configuration information in its Centralized Management System (CMS) database. You can manually back up the CMS database contents for greater system reliability.

The CMS database backup is in a proprietary format that contains an archive database dump, WAAS Central Manager registration information, and device information that the WAAS Central Manager uses to communicate with other WAAS devices. CMS database backup files are not interchangeable between primary and standby WAAS Central Manager devices. This means that you cannot use the backup file from a primary WAAS Central Manager to restore a standby WAAS Central Manager.

To back up the CMS database for the WAAS Central Manager, use the **cms database backup** EXEC command. For database backups, specify the location, password, and user ID of the remote server that you want to store the backup file in. If you want to back up only the configuration information, use the **cms database backup config** EXEC command.

**Note**

If you have already performed a backup when the secure store was in user-passphrase mode and you restored it to a system where the secure store is in auto-passphrase mode, you must enter the user passphrase to proceed with the restore. After the restore, the system is in user-passphrase mode. If you already performed a backup when the secure store was in auto-passphrase mode and you restored it to a system where the secure store is in user-passphrase mode, you do not have to enter a password. After the restore, the system is in auto-passphrase mode.

To back up and restore the CMS database, follow these steps:

- Step 1** On the WAAS Central Manager GUI, use the **cms database backup** command to back up the CMS database to a file, as shown in the following example:

```
CM# cms database backup
Creating database backup file backup/cms-db-11-05-2010-15-22_4.3.1.0.1.dump
Backup file backup/cms-db-11-05-2010-15-22_4.3.1.0.1 is ready.
Please use `copy` commands to move the backup file to a remote host.
```

**Note**

The backup file is automatically given a name in the format `cms-db-date-timestamp_version.dump`, for example, `cms-db-7-22-2010-17-36_4.3.1.0.1.dump`. Note that the timestamp is in a 24-hour format (HH:MM) that does not show seconds. It is stored in `/local1/backup`.

- Step 2** Save the file to a remote server by using the **copy disk ftp** command. This command copies the file from a local disk to a remote FTP server.

```
CM# cd /local1/backup
CM# copy disk ftp 10.86.32.82 /incoming cms-db-7-22-2008-17-36_4.1.3.0.1.dump
cms-db-7-22-2008-17-36_4.1.3.0.1.dump

Enter username for remote ftp server:ftp
Enter password for remote ftp server:*****
Initiating FTP upload...
Sending:USER ftp
10.86.32.82 FTP server (Version wu-2.6.1-18) ready.
Password required for ftp.
Sending:PASS *****
User ftp logged in.
Sending:TYPE I
Type set to I.
Sending:PASV
Entering Passive Mode (10,86,32,82,112,221)
Sending:CWD /incoming
CWD command successful.
Sending PASV
Entering Passive Mode (10,86,32,82,203,135)
Sending:STOR cms-db-7-22-2008-17-36_4.1.3.0.1.dump
Opening BINARY mode data connection for cms-db-7-22-2008-17-36_4.1.3.0.1.dump.
Transfer complete.
Sent 18155 bytes
```

Step 3 Restore the CMS database as follows:

- a. Disable the CMS service:

```
CM# configure
CM(config)# no cms enable
CM(config)# exit
```



Note Stopping the CMS service disables the WAAS Central Manager GUI. All the users who are currently logged in to this GUI are automatically logged out after the CMS service is disabled.

- b. Delete the existing CMS database:

```
CM# cms database delete
```

- c. Initialize the CMS database:

```
CM# cms database create
```

- d. Restore the CMS database contents from the backup file:

```
CM# cms database restore backup/cms-db-7-22-2008-17-36_4.1.3.0.1.dump
```



Note After the restore, any WAEs that were registered with the Central Manager during the time since the backup was created will be disconnected from the Central Manager because there is no information about them in the backup file. To bring these WAEs online, you must deregister and reregister them with the Central Manager. On each WAE that was disconnected, use the following commands:

```
WAE# cms deregister force
WAE# configure
WAE(config)# cms enable
```

- e. Enable the CMS service on the Central Manager:

```
CM# configure
CM(config)# cms enable
```



Note If you want to upgrade the Central Manager to a newer model, backing up the former Central Manager's database and restoring it on the new device prevents it from being used as a WAE later. For more information, see the [Upgrading Central Manager to New Hardware and Converting an Existing Central Manager to a WAE](#).

Backing Up and Restoring a WAE Device

You should back up the database of each WAAS device on a regular basis in case a system failure occurs.

**Note**

The backup and restore methods described in this section apply only to a WAE device that is not configured as a WAAS Central Manager. For information on backing up the WAAS Central Manager device, see [Backing Up and Restoring the WAAS Central Manager Database](#).

You can use **either** of the following methods to back up and restore the database of an individual WAE device: **WAE Device Manager**.

- CLI—Use the **copy running-config** command to back up and restore a device's configuration. This command saves the currently running configuration.

Additionally, you can restore a WAE to the default configuration that it was manufactured with at any time by removing the user data from the disk and Flash memory, and erasing all the existing files cached on the appliance. Basic configuration information, such as network settings, can be preserved. The appliance is accessible through Telnet and Secure Shell (SSH) after it reboots.

**Note**

If software upgrades have been applied, the restoration process returns to the defaults of the currently installed version and not the factory defaults.

To restore a WAE to its factory defaults or the defaults of the current configuration from the CLI, use the **restore factory-default [preserve basic-config] EXEC** command.

For more information about the CLI commands, see the [Cisco Wide Area Application Services Command Reference Guide](#).

Reinstalling the System Software

This section contains instructions for using the software recovery files to reinstall your system software if for some reason the software that is installed has failed. A software recovery CD-ROM ships with some WAE and WAVE hardware devices. Some WAVE devices use a USB flash drive for recovery.

**Caution**

If you upgraded your software after you received your software recovery CD-ROM or image files, using the recovery software images may downgrade your system. Ensure that you are using the desired software recovery version.

The WAAS software consists of three basic components:

- Disk-based software
- Flash-based software
- Hardware platform cookie (stored in flash memory)

All of these components must be correctly installed for WAAS software to work properly.

The software is contained in two types of software images provided by Cisco Systems:

- A .bin image that contains disk and flash memory components (the Universal version of the WAAS software)
- A .sysimg image that contains a flash memory component only

An installation that contains only the WAAS flash memory-based software, without the corresponding disk-based software, boots and operates in a limited mode, allowing for further disk configuration before completing a full installation.

The .sysimg component is provided for recovery purposes and allows for repair of flash memory only without modifying the disk contents.



Note The system image that is used depends on your device. For all WAVE devices (64-bit platforms), use the 64-bit system image (with “x86_64” in its name). For all other devices, use the 32-bit system image named without this designator.

A Network Processing Engine (NPE) image that has the disk encryption feature disabled for use in countries where disk encryption is not permitted, is provided.

If you have a WAVE appliance that requires a USB flash drive for software recovery, your USB flash drive must contain both of the needed software images in the form of an ISO archive file that you copy to the flash drive. (See [Preparing the USB Flash Drive](#)).

These options are available from the software recovery installer menu:

- **Option 1: Configure Network**—If the .bin image you need to install is located on the network instead of the CD-ROM or USB flash drive (which may be the case when an older CD-ROM or USB image is used to install new software), then you must choose this option to configure the network before attempting to install the .bin image.

This option is performed automatically if you install a .sysimg file from the network.

- **Option 2: Manufacture Flash**—This option verifies the flash memory and, if invalid, automatically reformats it to contain a Cisco standard layout. If reformatting is required, a new cookie is installed automatically.

This option is performed automatically as part of a .bin or .sysimg installation.

- **Option 3: Install Flash Cookie**—This option generates a hardware-specific platform cookie and installs it in flash memory. Use this option only if there has been a change in the hardware components, such as replacing the motherboard, or if you moved a flash memory card between systems.

This option is performed automatically during the flash manufacturing process, if needed, as part of a .bin or .sysimg installation.

- **Option 4: Install Flash Image from Network and Option 5: Install Flash Image from USB/CD-ROM**—These options allow installation of only the flash memory .sysimg and do not modify disk contents. They can be used when a new chassis has been provided and populated with a customer’s old disks that need to be preserved.

These options automatically perform flash verification and hardware cookie installation, if required. When installing from the network, you are prompted to configure the network if you have not already done so.

- **Option 6: Install Flash Image from Disk**—This option is reserved for future expansion and is not available.
- **Option 7: Re-create RAID device**—This option applies only to WAVE-7541, WAVE-7571, and WAVE-8541 devices and re-creates the RAID array.
- **Option 8: Wipe Out Disks and Install .bin Image**—This option provides the preferred procedure for installing the WAAS software.



Caution Option 8 erases the content from the all disk drives in your device.

This option performs the following steps:

- a. Checks that flash memory is formatted to Cisco specifications. If yes, the system continues to step b. If no, the system reformats the flash memory, which installs the Cisco file system, and generates and installs a platform-specific cookie for the hardware.
 - b. Erases data from all drives.
 - c. Re-manufactures the default Cisco file system layout on the disk.
 - d. Installs the flash memory component from the .bin image.
 - e. Installs the disk component from the .bin image.
- Option 9: Exit (reboot)—This option ejects the CD-ROM (if applicable) and reboots the device. If you are using a USB flash drive for software installation, remove it from the device before rebooting.

The following sections describe how to reinstall the WAAS system software:

- [Preparing the USB Flash Drive](#)—Read this section if you have a WAVE appliance that requires a USB flash drive instead of a CD to install the system software.
- [Reinstalling the System Software](#)—Describes how to reinstall the system software from a CD or USB flash drive.
- [Ensuring that RAID Pairs Rebuild Successfully](#)—Describes how to ensure that RAID disks rebuild successfully.

Preparing the USB Flash Drive

If you have a WAVE appliance that requires a USB flash drive for software recovery, you must prepare the USB flash drive with the appropriate files before you can start the software recovery process. You will need the following:

- Windows PC (Windows XP or 7) or Mac computer
- USB flash drive that is 1 GB or larger in size
- The following software recovery files:
 - WAAS Rescue CD ISO image file, which is available in the [WAAS Software Download](#) area of Cisco.com. The filename is similar to waas-rescue-cdrom-x.x.x.x-k9.iso, where the *x*'s denote the software version number. Alternatively, the ISO image file is available on the WAAS release DVD, or you can make an ISO image file from a WAAS recovery CD.
 - The syslinux.cfg file, which is also available in the [WAAS Software Download](#) area of Cisco.com and on the WAAS release DVD.
 - Unetbootin utility for Windows or MAC, which is available from the Unetbootin Sourceforge website.

To prepare the USB flash drive on a Windows or MAC computer, follow these steps:

-
- Step 1** Transfer the software recovery files on to the computer, noting the directory in which they are stored.
 - Step 2** Insert the USB flash drive into a USB port on the computer.
 - Step 3** Open My Computer (Windows) or Disk Utility (MAC).
 - Step 4** Format the USB flash drive:
 - For Windows, right click the **Removable Disk** (drive letter will vary with system) and select **Format**.
 - In the formatting tool, from the **File System** drop-down list, select FAT32.
 - In the **Format Options** sections, check the **Quick Format** check box, and then click **Start**.

- Click OK on the warning message.
 - Close the formatting tool after the formatting is complete.
 - For MAC, select the USB drive on the left side of window, and use the **Erase** tab to format for use with MS-DOS (FAT).
- Step 5** Launch the Unetbootin utility.
- Step 6** Select the Diskimage option and click the corresponding **browse** button (...) to select the waas-rescue-cdrom-x.x.x.x-k9.iso image file.
- Step 7** Ensure that USB Drive is selected in the **Type** drop-down list and that the correct drive letter is selected for **Drive**.
- Step 8** Click **OK** to install the bootable image in the USB flash drive. When the installation has completed, click **Exit**.
- Step 9** Drag a copy of the syslinux.cfg file into the USB flash drive and click Yes to confirm the replacement. This file replaces the existing file on the USB flash drive with the one customized for your WAAS system.
- Step 10** Remove the USB flash drive from the computer.
-

To continue reinstalling the system software from the prepared USB flash drive, follow the instructions in [Reinstalling the System Software](#).

Reinstalling the System Software

To reinstall the system software on a WAE appliance using the software recovery CD-ROM or USB flash drive, follow these steps:

- Step 1** Connect a serial console to the WAAS appliance and use the console for the following steps.
- Step 2** Insert the software recovery CD-ROM in the CD drive of the WAE device or, if the device uses a USB flash drive for recovery, insert a bootable USB flash drive with the software recovery files into the USB port of the device (see [Preparing the USB Flash Drive](#)). WAVE-294/594/694/7541/7571/8541 devices do not have CD drives; they use a USB flash drive for software recovery.
- Step 3** Reboot the WAE. During the boot process, the boot loader pauses for 30 seconds and you must choose the VGA console if you are using vWAAS. The prompt is displayed as follows:

```
Type "serial" for WAE/WAVE appliance.
Type "vga" for vWAAS.
boot:
```

Enter the **vga** command at the prompt to continue the boot process for the VGA console on vWAAS. After 30 seconds with no input, the boot process continues with the standard serial console for WAAS appliances.

After the WAE boots, you will see the following:

```
Installer Main Menu:
 1. Configure Network
 2. Manufacture flash
 3. Install flash cookie
 4. Install flash image from network
 5. Install flash image from usb/cdrom
 6. Install flash image from disk
```

```

7. Recreate RAID device (WAE-7541/7571/8541 only)
8. Wipe out disks and install .bin image
9. Exit (reboot)
Choice [0]:

```



Note The option numbers in the installer main menu may vary, depending on the WAAS software release being installed.

- Step 4** Choose Option 2, “Manufacture flash,” to prepare the flash memory.
- This step prepares a cookie for the device and also retrieves the network configuration that was being used by the WAAS software. This network configuration is stored in the flash memory and is used to configure the network when the WAAS software boots up after installation.
- Step 5** Choose Option 3, “Install flash cookie,” to install the flash cookie that you prepared in the previous step.
- Step 6** Choose Option 5, “Install flash image from usb/cdrom,” to install the flash image from a CD-ROM or USB flash drive.
- Step 7** (Optional) If you are working with a WAVE-7541, WAVE-7571, or WAVE-8541 device, choose option 7 to recreate the RAID array.
- Step 8** Choose Option 8, “Wipe out disks and install .bin image,” to wipe the disks and install the binary image.
- This step prepares the disks by erasing them. The WAAS software image is installed.
- Step 9** If you are using a USB flash drive to install the software, remove it from the device.
- Step 10** Choose Option 9, “Exit (reboot),” to reboot the WAE.
- After the WAE reboots, it runs the newly installed WAAS software. The WAE has a minimal network configuration and is accessible via the terminal console for further configuration.
-

To reinstall the system software on an NME-WAE network module installed in a Cisco access router, follow these steps:

- Step 1** Log in to the Cisco router in which the NME-WAE module is installed, and reload the NME-WAE module:
- ```

router-2851> enable
router-2851# service-module integrated-Service-Engine 1/0 reload

```
- Step 2** Immediately open a session in the module:
- ```

router-2851# service-module integrated-Service-Engine 1/0 session

```
- Step 3** While the module is loading, you will see the following option during boot phase 3. Enter *** as instructed:
- ```

[BOOT-PHASE3]: enter `***' for rescue image: ***

```
- Step 4** The **Rescue Image** dialog is displayed. The following example shows how to interact with the Rescue Image dialog box (user input is denoted by entries in bold typeface):
- ```

This is the rescue image. The purpose of this software is to let
you install a new system image onto your system's boot flash
device. This software has been invoked either manually
(if you entered `***' to the bootloader prompt) or has been
invoked by the bootloader if it discovered that your system image
in flash had been corrupted.

```

To download an image from network, this software will request the following information from you:

- which network interface to use
- IP address and netmask for the selected interface
- default gateway IP address
- FTP server IP address
- username and password on FTP server
- path to system image on server

Please enter an interface from the following list:

- 0: GigabitEthernet 1/0
- 1: GigabitEthernet 2/0

enter choice: **0**

Using interface GigabitEthernet 1/0

Please enter the local IP address to use for this interface:

[Enter IP Address]: **10.1.13.2**

Please enter the netmask for this interface:

[Enter Netmask]: **255.255.255.240**

Please enter the IP address for the default gateway:

[Enter Gateway IP Address]: **10.1.13.1**

Please enter the IP address for the FTP server where you wish to obtain the new system image:

[Enter Server IP Address]: **10.107.193.240**

Please enter your username on the FTP server (or 'anonymous'):

[Enter Username on server (e.g. anonymous)]: **username**

Please enter the password for username 'username' on FTP server:

Please enter the directory containing the image file on the FTP server:

[Enter Directory on server (e.g. /)]: **/**

Please enter the file name of the system image file on the FTP server:

[Enter Filename on server]: **WAAS-5.1.1.10-K9.sysimg**

Here is the configuration you have entered:

Current config:

```

IP Address: 10.1.13.2
Netmask: 255.255.255.240
Gateway Address: 10.1.13.1
Server Address: 10.107.193.240
Username: username
Password: *****
Image directory: /
Image filename: WAAS-5.1.1.10-K9.sysimg

```

Attempting download...

Downloaded 15821824 byte image file

A new system image has been downloaded.

You should write it to flash at this time.

Please enter 'yes' below to indicate that this is what you want to do:

[Enter confirmation ('yes' or 'no')]: **yes**

Ok, writing new image to flash

..... done.

Finished writing image to flash.

Enter 'reboot' to reboot, or 'again' to download and install a new image:

[Enter reboot confirmation ('reboot' or 'again')]: **reboot**

Restarting system.

Step 5 After the module reboots, install the .bin image from an HTTP server:

```
NM-WAE-1# copy http install 10.77.156.3 /waas WAAS-5.1.1.10-k9.bin
```

Step 6 Reload the module:

```
NM-WAE-1# reload
```

After the module reboots, it runs the newly installed WAAS software.

Ensuring that RAID Pairs Rebuild Successfully



Caution

You must ensure that all the RAID pairs have completed rebuilding before you reboot your WAE device. If you reboot while the device is still rebuilding, you risk corrupting the file system.

RAID pairs will rebuild on the next reboot after you use the **restore factory-default** command, replace or add a hard disk drive, delete disk partitions, or reinstall WAAS from the booted recovery CD-ROM or USB flash drive.

To view the status of the drives and check if the RAID pairs are in “NORMAL OPERATION” or in “REBUILDING” status, use the **show disk details EXEC** command. When you see that RAID is rebuilding, you must let it complete that rebuild process. This rebuild process can take several hours.

If you do not wait for the RAID pairs to complete the rebuild process before you reboot the device, you may see the following symptoms indicating a problem:

- The device is offline in the Central Manager GUI.
- CMS cannot be loaded.
- Error message stating that the file system is read-only is displayed.

The syslog contains errors such as:

```
-Aborting journal on device md2  
-Journal commit I/O error  
-Journal has aborted  
-ext3_readdir: bad entry in directory
```

- Other unusual behaviors related to disk operations or the inability to perform them are visible.

If you encounter any of these symptoms, reboot the WAE device and wait until the RAID rebuild finishes normally.

Recovering the System Software

WAAS devices have a resident rescue system image that is invoked if the image in flash memory is corrupted. A corrupted system image can result from a power failure that occurs while a system image is being written to flash memory. The rescue image can help you download a system image to the main memory of the device and write it to flash memory.



Note The system image used depends on your device. For all WAVE and WAE devices (64-bit platforms), use the 64-bit system image (with “x86_64” in its name). For all other devices, use the 32-bit system image named without this designator.

An NPE image that has the disk encryption feature disabled for use in countries where disk encryption is not permitted is provided.

To install a new system image using the rescue image, follow these steps:

-
- Step 1** Download the system image file (*.sysimg) to a host that is running an FTP server.
- Step 2** Establish a console connection to the WAAS device and open a terminal session.
- Step 3** Reboot the device by toggling the power on/off switch.
- After a few seconds, the bootloader pauses and prompts you to enter 1 to boot WAAS, r to boot the rescue image, x to reboot, or 9 to escape to the loader prompt. You have 10 seconds to respond before the normal boot process continues.
- Step 4** Enter r to boot the rescue image.
- The **Rescue Image** dialog box is displayed and differs depending on whether your WAAS device was initially manufactured with Version 4.x or 5.x. [Step 5](#) describes the rescue image on a device that was initially manufactured with Version 5.x. [Step 6](#) describes the rescue image on a device that was initially manufactured with Version 4.x.
- Step 5** If you see the following output (from a device that was initially manufactured with Version 5.x), log in and use the **copy install** command to install the WAAS system software image (.bin file), as shown in the following example (user input is denoted by entries in bold typeface):

```
The device is running WAAS rescue image. WAAS functionality is unavailable
in a rescue image. If the rescue image was loaded by accident, please reload
the device. If the rescue image was loaded intentionally to reinstall WAAS software
please use the following command:
```

```
copy [ftp|http|usb] install ...
```

```
SW up-to-date
```

```
...
```

```
Cisco Wide Area Virtualization Engine Console
```

```
Username: admin
```

```
Password:
```

```
System Initialization Finished.
```

```
WAVE# copy ftp install 172.16.10.10 / waas-universal-5.1.1.12-k9.bin
```

```
...
```

```
Installing system image to flash... Creating backup of database content before database
upgrade.
```

```
The new software will run after you reload.
```

```
WAVE# reload
```

```
Proceed with reload?[confirm]yes
```

```
Shutting down all services, will timeout in 15 minutes.
```

```
reload in progress ..Restarting system.
```

Step 6 If you see the following output (from a device that was initially manufactured with Version 4.x), log in and install the WAAS system image (.sysimg file), as shown in the following example (user input is denoted by entries in bold typeface):

```
This is the rescue image. The purpose of this software is to let
you download and install a new system image onto your system's
boot flash device. This software has been invoked either manually
(if you entered `***' to the bootloader prompt) or has been
invoked by the bootloader if it discovered that your system image
in flash had been corrupted.
```

```
To download an image, this software will request the following
information from you:
```

- which network interface to use
- IP address and netmask for the selected interface
- default gateway IP address
- server IP address
- which protocol to use to connect to server
- username/password (if applicable)
- path to system image on server

```
Please enter an interface from the following list:
```

```
0: GigabitEthernet 0/0
1: GigabitEthernet 0/1
```

```
enter choice: 0
```

```
Using interface GigabitEthernet 0/0
```

```
Please enter the local IP address to use for this interface:
```

```
[Enter IP Address]: 172.16.22.22
```

```
Please enter the netmask for this interface:
```

```
[Enter Netmask]: 255.255.255.224
```

```
Please enter the IP address for the default gateway:
```

```
[Enter Gateway IP Address]: 172.16.22.1
```

```
Please enter the IP address for the FTP server where you wish
to obtain the new system image:
```

```
[Enter Server IP Address]: 172.16.10.10
```

```
Please enter your username on the FTP server (or 'anonymous'):
```

```
[Enter Username on server (e.g. anonymous)]: anonymous
```

```
Please enter the password for username 'anonymous' on FTP server:
```

```
Please enter the directory containing the image file on the FTP server:
```

```
[Enter Directory on server (e.g. /)]: /
```

```
Please enter the file name of the system image file on the FTP server:
```

```
[Enter Filename on server (e.g. WAAS-x86_64-4.x.x-K9.sysimg)]:
```

```
waas-x86_64-5.1.1.12-k9.sysimg
```

```
Here is the configuration you have entered:
```

```
Current config:
```

```
IP Address: 172.16.22.22
Netmask: 255.255.255.224
Gateway Address: 172.16.22.1
Server Address: 172.16.10.10
Username: anonymous
Password:
Image directory: /
Image filename: waas-x86_64-5.1.1.12-k9.sysimg
```

```
Attempting download...
```

```

Downloaded 31899648 byte image file
A new system image has been downloaded.
You should write it to flash at this time.
Please enter 'yes' below to indicate that this is what you want to do:
[Enter confirmation ('yes' or 'no')]: yes
Ok, writing new image to flash
Finished writing image to flash.
Enter 'reboot' to reboot, or 'again' to download and install a new image:
[Enter reboot confirmation ('reboot' or 'again')]: reboot
Restarting system.
Booting system, please wait.....

```

Step 7 Log in to the device with the username **admin**. Verify that you are running the correct version by entering the **show version** command:

```

Username: admin
Password:

Console# show version
Cisco Wide Area Application Services Software (WAAS)
Copyright (c) 1999-2012 by Cisco Systems, Inc.
Cisco Wide Area Application Services (universal-k9) Software Release 5.1.1 (build b12 Nov 12 2012)
Version: oe294-5.1.1.12

Compiled 12:23:45 Nov 12 2012 by damaster

Device Id: 50:3d:e5:9c:8f:a5
System was restarted on Mon Nov 12 16:35:50 2012.
System restart reason: called via cli.
The system has been up for 8 hours, 10 minutes, 19 seconds.

```

Recovering a Lost Administrator Password

If an administrator password is forgotten, lost, or misconfigured, you will have to reset the password on the device.



Note

You cannot restore a lost administrator password. You must reset the password, as described in this procedure.

To reset the password, follow these steps:

Step 1 Establish a console connection to the device and open a terminal session.

Step 2 Reboot the device.

While the device is rebooting, watch for the following prompt, and press **Enter** when you see it:

```
Cisco WAAS boot:hit RETURN to set boot flags:0009
```

Step 3 When prompted to enter bootflags, enter the value: **0x8000**:

```

Available boot flags (enter the sum of the desired flags):
0x4000 - bypass nvram config
0x8000 - disable login security

[CE boot - enter bootflags]:0x8000

```



```
You have entered boot flags = 0x8000
Boot with these flags? [yes]:yes
```

[Display output omitted]

Setting the configuration flags to **0x8000** lets you into the system, bypassing all security. Setting the configuration flags field to **0x4000** lets you bypass the NVRAM configuration.

- Step 4** When the device completes the boot sequence, you are prompted to enter the username to access the CLI. Enter the default administrator username (**admin**).

```
Cisco WAE Console
```

```
Username: admin
```

- Step 5** When you see the CLI prompt, set the password for the user using the **username passwd** command in global configuration mode:

```
WAE# configure
WAE(config)# username admin passwd
```

This command invokes interactive password configuration. Follow the CLI prompts.

- Step 6** Save the configuration change:

```
WAE(config)# exit
WAE# write memory
```

- Step 7** (Optional) Reboot your device:

```
WAE# reload
```

Rebooting is optional. However, we recommend that you reboot to ensure that the boot flags are reset, and to ensure that subsequent console administrator logins do not bypass the password check.



Note In the WAAS software, the bootflags are reset to 0x0 on every reboot.

Recovering from Missing Disk-Based Software

This section describes how to recover from the following types of disk drive issues:

- Your WAAS device contains a single disk drive that needs to be replaced due to a disk failure.
- Your WAAS device contains two disk drives and you intentionally deleted the disk partitions on both drives (diks00 and disk01).

Systems with two or more disk drives are normally protected automatically by RAID-1 on critical system partitions. Therefore, the procedures in this section do not have to be followed when replacing a disk drive in a multidrive system.

To recover from this condition, follow these steps:

- Step 1** Deactivate the device by completing the following steps:
- a. From the WAAS Central Manager menu, go to **Devices > device-name**.
 - b. Choose **device-name > Activation**. The Device Activation window appears.

- c. Uncheck the **Activate** check box, and then click **Submit**.

The device is deactivated.

Step 2 Power down the device and replace the failed hard drive.

Step 3 Power on the device.

Install the WAAS software. For more information on initial configuration, see the [Cisco Wide Area Application Services Quick Configuration Guide](#).

Step 4 Use the CMS identity recovery procedure to recover the device CMS identity and associate this device with the existing device record on the WAAS Central Manager. For more information, see [Recovering WAAS Device Registration Information](#).

Recovering WAAS Device Registration Information

Device registration information is stored both on the device itself and on the WAAS Central Manager. If a device loses its registration identity or needs to be replaced because of a hardware failure, the WAAS network administrator can issue a CLI command to recover the lost information, or in the case of adding a new device, assume the identity of the failed device.

To recover lost registration information, or to replace a failed device with a new one having the same registration information, follow these steps:

Step 1 Mark the failed device as Inactive and Replaceable by completing the following steps:

- a. From the Central Manager menu, choose **Devices** > *device-name*.
- b. Choose *device-name* > **Activation**.
- c. Uncheck the **Activate** check box. The window refreshes, displaying a check box for marking the device as replaceable.
- d. Check the **Replaceable** check box, and click **Submit**.



Note This check box appears in the GUI only when the device is inactive.

Step 2 If the failed device is configured as a nonoptimizing peer with another device, disable the peer settings on the other device.

A message is displayed if the failed device is a nonoptimizing peer, indicating that the device is a nonoptimizing peer. When a device is replaced, its device ID changes and therefore, the nonoptimizing peer configuration must be updated.

- a. From the WAAS Central Manager menu, choose **Configure** > **Global** > **Peer Settings**. The Peer Settings window for all the devices appears.
- b. Click the **Edit** icon next to the nonoptimizing device identified in the message, which will appear in red because its peer is unknown. The Peer Settings window for that device appears.
- c. Click the **Remove Device Settings** icon in the taskbar.
- d. Click **Submit**.

Step 3 Configure a system device recovery key as follows:

- a. From the WAAS Central Manager menu, choose **Configure** > **Global** > **System Properties**.

- b. Click the **Edit** icon next to the `System.device.recovery.key` property. The Modifying Config Property window appears.
- c. Enter the password in the **Value** field, and click **Submit**. The default password is **default**.

Step 4 Configure the basic network settings for the new device.

Step 5 Open a Telnet session to the device CLI and enter the `cms recover identity keyword EXEC` command. Here, *keyword* is the device recovery key that you configured in the WAAS Central Manager GUI.

When the WAAS Central Manager receives the recovery request from the WAAS device, it searches its database for the device record that meets the following criteria:

- The record is inactive and replaceable.
- The record has the same hostname or primary IP address, as given in the recovery request.

If the recovery request matches the device record, then the WAAS Central Manager updates the existing record and sends the requesting device a registration response. The replaceable state is cleared so that no other device can assume the same identity. When the WAAS device receives its recovered registration information, it writes it to file, initializes its database tables, and starts.

Step 6 Enter the following commands to enable the CMS service on the device:

```
WAE# config
WAE(config)# cms enable
WAE(config)# exit
```

Step 7 Activate the device:

- a. From the WAAS Central Manager menu, choose **Devices > device-name**.
- b. Choose *Device Name > Activation*. The WAAS device status should be Online.
- c. Check the **Activate** check box, and click **Submit**.

Step 8 (Optional) Reconfigure the device peer settings, if the device was configured as a nonoptimizing peer with another device (see [Information About Clustering Inline WAEs](#) in Chapter 5, “Configuring Traffic Interception”).

Step 9 Save the device configuration settings by entering the `copy running-config startup-config EXEC` command.

Performing Disk Maintenance for RAID-1 Systems

WAAS supports hot-swap functionality for both failed disk replacement and scheduled disk maintenance. When a disk fails, WAAS automatically detects the disk failure, marks the disk as bad, and removes the disk from the RAID-1 volume. To schedule disk maintenance, you must manually shut down the disk.

You must wait for the disk to be completely shut down before you physically remove the disk from the WAE. When the RAID removal process is complete, WAAS generates a disk failure alarm and trap. In addition, a syslog error message is logged.



Note

If the removal event (such as, a disk failure or software shutdown) occurs while the RAID array is in the rebuild process, the RAID removal process may take up to 1 minute to complete. The duration of this process depends on the size of the disk.

If the WAAS software removes a failed disk during the RAID rebuild process, a RAID rebuild failure alarm is generated. If you administratively shut down the disk during the RAID rebuild process, a RAID rebuild abort alarm is generated instead.

When you install a replacement disk, the WAAS software detects the replacement disk and performs compatibility checks on the disk, initializes the disk by creating partitions, and adds the disk to the software RAID to start the RAID rebuild process.

If the newly inserted disk has the same disk ID as a disk that was previously marked bad in the same physical slot, then the disk will not be mounted, and the post-replacement checks, initialization, and RAID rebuilding will not occur.

A newly installed disk must be of the same type and speed as the old disk and it must meet the following compatibility requirements:

- If the replacement disk is for disk00, disk02, or disk04 of a RAID pair, the replacement disk must be the same size as the running disk in the array.
- If the replacement disk is for disk01, disk03, or disk05 of a RAID pair, then the replacement disk must have the same or greater RAID capacity as the running disk in the array.

Compatibility checks, which are a part of the hot-swap process, check for capacity compatibility. Incompatibility generates an alarm and aborts the hot-swap process.

To perform disk maintenance, follow these steps:

Step 1 Manually shut down the disk.

- a. Enter global configuration mode and then enter the **disk disk-name diskxx shutdown** command:

```
WAE# configure
WAE(config)# disk disk-name diskxx shutdown
```

- b. Wait for the disk to be completely shut down before you physically remove the disk from the WAE. When the RAID removal process is complete, WAAS generates a disk failure alarm and trap. In addition, a syslog error message is logged.



Note We recommend that you disable the **disk error-handling reload** option if it is enabled because it is not necessary to power down the system to remove a disk.

Step 2 Insert a replacement disk into the slot in the WAE. The replacement disk must have a disk ID number that is different from the disk that it is replacing.

Step 3 Re-enable the disk by running the **no disk disk-name diskxx shutdown** global configuration command.

Removing and Replacing Disks in RAID-5 Systems

To remove and replace a physical disk drive in a system that uses a RAID-5 logical drive, follow these steps:

Step 1 Enter the **disk disk-name diskxx replace** command in EXEC mode from the WAAS CLI on the WAE.

Step 2 Verify that the disk drive *diskxx* is in Defunct state by entering the **show disks details** command in EXEC mode. The RAID logical drive is in Critical state at this point.

- Step 3** Move the handle on the drive to the open position (perpendicular to the drive).
- Step 4** Pull the hot-swap drive assembly from the bay.
- Step 5** Wait for one minute and then insert the new drive into the same slot by aligning the replacement drive assembly with guide rails in the bay and sliding the drive assembly into the bay until it stops. Make sure that the drive is properly seated in the bay.
- Step 6** Close the drive handle.
- Step 7** Check the hard disk drive status LED to verify that the hard disk drive is operating correctly. If the amber hard disk drive status LED for a drive is lit continuously, that drive is faulty and must be replaced. If the green hard disk drive activity LED is flashing, it means the drive is being accessed.

**Note**

If a disk is shut down using the **disk disk-name diskxx replace EXEC** command and the same disk is removed and reinserted, it can be reenabled by using the EXEC command **disk disk-name diskxx enable force**. This process is applicable even if the disk is not removed and needs to be re-enabled. This command is not applicable if a new disk is inserted.

- Step 8** Wait for 1 minute and then verify that the replaced disk drive is in the Rebuilding state by using the **show disks details** command in EXEC mode.

**Note**

The ServeRAID controller automatically starts the rebuild operation when it detects the removal and reinsertion of a drive that is a part of the logical RAID drive.

- Step 9** Wait until the rebuild operation is complete. You can check if the rebuild operation is complete by using the **show disks details** command in EXEC mode. The physical drive state will be Online and the RAID logical drive state will be Okay after the rebuild operation is completed.
- Step 10** Reinstall the software on the device. For more information, refer to [Upgrading the WAAS Software](#)
- Step 11** Add the license. For more information, refer to [Managing Software Licenses](#) in Chapter 10, “Configuring Other System Settings.”
- Step 12** Register the WAE to the WAAS Central Manager.

A 300-GB SAS drive may take up to 5 hours to finish rebuilding.

If you have multiple disk failures and your RAID-5 logical status is Offline, you must re-create the RAID-5 array by following these steps:

- Step 1** From the global configuration mode, run the **disk logical shutdown** command to disable the RAID-5 array.
- Step 2** Run the **write** command in EXEC mode to save the running configuration to NV-RAM.
- Step 3** Run the **reload** command in EXEC mode to reload the system.
- Step 4** Run the **show disks details** command in EXEC mode to check the system configuration after the system is reloaded. At this point, the disks are not mounted and the logical RAID drive should be in the Shutdown state.
- Step 5** Run the **disk recreate-raid** command in EXEC mode to recreate the RAID-5 array.
- Step 6** After successful execution of the **disk recreate-raid** command, enter global configuration mode and run the **no disk logical shutdown** command to disable the logical disk shutdown configuration.

- Step 7** Run the **write** command in EXEC mode to save the configuration to NV-RAM.
- Step 8** Run the **reload** command in EXEC mode to reload the system.
- Step 9** Run the **show disks details** command in EXEC mode to check the system configuration after the system is reloaded. At this point, the disks should be mounted and the logical RAID drive should *not* be in the Shutdown state.
- Step 10** Wait until the rebuild operation is complete. You can check if the rebuild operation is complete by running the **show disks details** command in EXEC mode. The physical drive state will be Online and the RAID logical drive state will be Okay after the rebuild operation is completed.

It takes several hours to finish rebuilding the RAID-5 array.

After a multiple disk failure or RAID controller failure, and after the drives are replaced and the RAID disk is rebuilt, the logical disk may remain in the error state. To re-enable the disk, use the **no disk logical shutdown force** command, and then reload the WAE.

Configuring the Central Manager Role

The WAAS software implements a standby WAAS Central Manager. This process allows you to maintain a copy of the WAAS network configuration on a second WAAS Central Manager device. If the primary WAAS Central Manager fails, the standby can be used to replace the primary.

For interoperability, when a standby WAAS Central Manager is used, it must be at the same software version as the primary WAAS Central Manager to maintain the full WAAS Central Manager configuration. Otherwise, the standby WAAS Central Manager detects this status and does not process any configuration updates that it receives from the primary WAAS Central Manager until the problem is corrected.



Note

Primary and standby Central Managers communicate on port 8443. If your network includes a firewall between primary and standby Central Managers, you must configure the firewall to allow traffic on port 8443 so that the Central Managers can communicate and stay synchronized.

This section contains the following topics:

- [Converting a WAE to a Standby Central Manager](#)
- [Converting a Primary Central Manager to a Standby Central Manager](#)
- [Converting a Standby Central Manager to a Primary Central Manager](#)
- [Switching Both the Central Manager Roles](#)
- [Central Manager Failover and Recovery](#)

Converting a WAE to a Standby Central Manager

This section describes how to convert a WAE that is operating as an application accelerator to a standby Central Manager.

There are two types of WAAS software files:

- Universal—Includes Central Manager, Application Accelerator, and AppNav Controller functionality.
- Accelerator only—Includes Application Accelerator and AppNav Controller functionality only. If you want to change an Application Accelerator or AppNav Controller to a Central Manager, you must use the Universal software file.

If the WAE is operating with an Accelerator only image, you cannot convert it to a Central Manager until after you update it with the Universal software file, reload the device, change the device mode to central-manager, and then reload the device again. For information on updating a WAE, see [Upgrading the WAAS Software](#).

Use the **show version EXEC** command to check if the WAE is running an Accelerator only image. Also, the **show running-config EXEC** command displays the image type.

To convert a WAE with a Universal image to a standby Central Manager, follow these steps:

-
- Step 1** Deregister the WAE from the Central Manager using the **cms deregister force** command:
- ```
WAE# cms deregister force
```
- This command cleans up any previous association to any other Central Manager.
- Step 2** Configure the device mode as Central Manager using the **device mode** command:
- ```
WAE# configure
WAE(config)# device mode central-manager
```
- Step 3** You must reload the device to apply the changes. For more information on reloading and rebooting a device, see [Rebooting a Device or Device Group](#).
- Step 4** Configure the Central Manager role as standby using the **central-manager role standby** command:
- ```
WAE(config)# central-manager role standby
```
- Step 5** Configure the address of the primary Central Manager using the **central-manager address** command:
- ```
WAE(config)# central-manager address cm-primary-address
```
- Step 6** Enable the CMS service using the **cms enable** command:
- ```
WAE(config)# cms enable
```
- 

## Converting a Primary Central Manager to a Standby Central Manager

To convert a primary Central Manager to a standby Central Manager, follow these steps:

- 
- Step 1** Deregister the Central Manager using the **cms deregister** command:
- ```
WAE# cms deregister
```
- This command cleans up any previous association to any other Central Manager.
- Step 2** Configure the Central Manager role as standby using the **central-manager role standby** command:
- ```
WAE# configure
WAE(config)# central-manager role standby
```
- Step 3** Configure the address of the primary Central Manager using the **central-manager address** command:

```
WAE(config)# central-manager address cm-primary-address
```

**Step 4** Enable the CMS service using the **cms enable** command:

```
WAE(config)# cms enable
```

## Converting a Standby Central Manager to a Primary Central Manager

If your primary WAAS Central Manager becomes inoperable, you can manually reconfigure one of your warm standby Central Managers to be the primary Central Manager. Configure the new role by using the global configuration **central-manager role primary** command as follows:

```
WAE# configure
WAE(config)# central-manager role primary
```

This command changes the role from standby to primary and restarts the management service to recognize the change.

If a previous failed primary Central Manager becomes available again, you can recover it to make it the primary Central Manager again. For details, see [Central Manager Failover and Recovery](#).

If you switch a warm standby Central Manager to primary while your primary Central Manager is still online and active, both Central Managers detect each other, automatically shut themselves down, and disable management services. The Central Managers are switched to halted, which is automatically saved in flash memory.

To return halted WAAS Central Managers to an online status, decide which Central Manager should be the primary device and which should be the standby device. On the primary device, execute the following CLI commands:

```
WAE# configure
WAE(config)# central-manager role primary
WAE(config)# cms enable
```

On the standby device, execute the following CLI commands:

```
WAE# configure
WAE(config)# central-manager role standby
WAE(config)# central-manager address cm-primary-address
WAE(config)# cms enable
```

## Switching Both the Central Manager Roles



### Caution

When you switch a WAAS Central Manager from primary to standby, the configuration on the Central Manager is erased. The Central Manager, after becoming a standby, will begin replicating its configuration information from the current primary Central Manager. If standby and primary units are not synchronized before switching roles, important configuration information can be lost.



Before you switch Central Manager roles, follow these steps:

- 
- Step 1** Ensure that your Central Manager devices are running the same version of WAAS software.
- Step 2** Synchronize the physical clocks on both devices so that both the WAAS Central Managers have the same Coordinated Universal Time (UTC) configured.
- Step 3** Ensure that the standby is synchronized with the primary by checking the status of the following items:
- Check the online status of your devices.  
The original standby Central Manager and all currently active devices should be showing as online in the Central Manager GUI. This step ensures that all other devices know about both Central Managers.
  - Check the status of recent updates from the primary WAAS Central Manager.  
Use the **show cms info EXEC** command and check the time of the last update. To be current, the value of the **Time of last config-sync** field should be between 1 and 5 minutes old. This time range verifies that the standby WAAS Central Manager has fully replicated the primary WAAS Central Manager configuration.  
If the update time is not current, determine whether or not there is a connectivity problem or if the primary WAAS Central Manager is down. Fix the problem, if necessary, and wait until the configuration has replicated, as indicated by the time of the last update.
- Step 4** Switch roles in the following order:
- Switch the original primary to standby mode:  

```
WAE1# configure
WAE1(config)# central-manager role standby
WAE1(config)# cms enable
```
  - Switch the original standby to primary mode:  

```
WAE2# configure
WAE2(config)# central-manager role primary
WAE2(config)# cms enable
```

The CMS service is restarted automatically after you configure a role change.

---

## Central Manager Failover and Recovery

If your primary WAAS Central Manager (WAAS CM) becomes inoperable, you can reconfigure one of your standby Central Managers to be the primary Central Manager, and later, when the failed Central Manager becomes available, you can reconfigure it to be the primary again. Follow these steps:

- 
- Step 1** Convert a standby Central Manager to be the primary Central Manager, as described in [Converting a Standby Central Manager to a Primary Central Manager](#).
- Step 2** When the failed Central Manager is available again, configure it as a standby Central Manager, as described in [Converting a Primary Central Manager to a Standby Central Manager](#), beginning with Step 2. Skip Step 1 and do not use the **cms deregister** command.
- Step 3** Switch both the Central Manager roles, as described in [Switching Both the Central Manager Roles](#).

**Note**

In some scenarios, when a Standby Central Manager (SCM) is registered newly with a WAAS Central Manager that is already managing more than 1000 WAEs, the devices may go off line. To avoid this, in case of large deployments, we recommend that you register the SCM to the Primary Central Manager (PCM) at the beginning of the deployment so that in case of an unexpected fail over the SCM takes up the PCM's role.

**Note**

When a backup operation is in progress on a SCM that is supporting a PCM managing more than 1000 WAEs, the SCM goes off line, if the backup operation takes more than 10 minutes. Additionally you will not be able to login to the PCM GUI when a backup operation is in progress.

## Enabling Disk Encryption

Disk encryption addresses the need to securely protect sensitive information that flows through deployed WAAS systems and that is stored in WAAS persistent storage. The disk encryption feature includes two aspects: the actual data encryption on the WAE disk and the encryption key storage and management.

When you enable disk encryption, all the data in WAAS persistent storage will be encrypted. The encryption key for unlocking the encrypted data is stored in the Central Manager, and key management is handled by the Central Manager. When you reboot the WAE after configuring disk encryption, the WAE retrieves the key from the Central Manager automatically, allowing normal access to the data that is stored in WAAS persistent storage.

**Note**

If a WAE is unable to reach the WAAS Central Manager during a reboot, it will do everything except mount the encrypted partitions. In this state, all traffic will be handled as pass-through. After communication with the WAAS Central Manager is restored (and the encryption key is obtained), the encrypted partitions are mounted. There is no loss of cache content.

Disk encryption requirements are as follows:

- You must have a Central Manager configured for use in your network.
- Your WAE devices must be registered with the Central Manager.
- Your WAE devices must be online (have an active connection) with the Central Manager. This requirement applies only if you are enabling disk encryption.
- You must reboot your WAE for the disk encryption configuration to take effect.

After you reboot your WAE, the encryption partitions are created using the new key, and any previously existing data is removed from the partition.

Any change to the disk encryption configuration, whether to enable or disable encryption, causes the disk to clear its cache. This feature protects sensitive customer data from being decrypted and accessed should the WAE ever be stolen.

If you enable disk encryption and then downgrade to a software version that does not support this feature, you will not be able to use the data partitions. In such cases, you must delete the disk partitions after you downgrade.

To enable and disable disk encryption from the Central Manager GUI, choose **Devices** > *device-name*, then choose **Configure** > **Storage** > **Disk Encryption**. To enable disk encryption, check the **Enable** check box and click **Submit**. This check box is unchecked by default. To disable disk encryption, uncheck the **Enable** check box and click **Submit**.

To enable and disable disk encryption from the WAE CLI, use the **disk encrypt** global configuration command.

**Note**

If you are using an NPE image, note that the disk encryption feature is disabled in countries where disk encryption is not permitted.

When you enable or disable disk encryption, the file system is reinitialized during the first subsequent reboot. Reinitialization may take from ten minutes to several hours, depending on the size of the disk partitions. During this time, the WAE will be accessible, but it will not provide any service.

If you change the Central Manager IP address, or if you relocate the Central Manager, or replace one Central Manager with another Central Manager that has not copied over all of the information from the original Central Manager, and you reload the WAE when disk encryption is enabled, the WAE file system will not be able to complete the reinitialization process or obtain the encryption key from the Central Manager.

If the WAE fails to obtain the encryption key, disable disk encryption by using the **no disk encrypt enable** global configuration command from the CLI, and reload the WAE. Ensure connectivity to the Central Manager before you enable disk encryption and reload the WAE. This process will clear the disk cache.

**Note**

When a standby Central Manager has been in service for at least two times, the datafeed poll rate time interval (approximately 10 minutes), and has received management updates from the primary Central Manager, the updates will include the latest version of the encryption key. Failover to the standby in this situation occurs transparently to the WAE. The datafeed poll rate defines the interval for the WAE to poll the Central Manager for configuration changes. This interval is 300 seconds by default.

To view the encryption status details, use the **show disks details EXEC** command. While the file system is initializing, **show disks details** displays the following message: “System initialization is not finished, please wait...” You can also view the disk encryption status, whether it is enabled or disabled, in the Central Manager GUI’s Device Dashboard window.

## Configuring a Disk Error-Handling Method

**Note**

Configuring and enabling disk error handling is no longer necessary for devices that support disk hot-swap. In WAAS 4.0.13 and later, the software automatically removes from service any disk with a critical error.

If the bad disk drive is a critical disk drive, and the automatic reload feature is enabled, then the WAAS software marks the disk drive *bad* and the WAAS device is automatically reloaded. After the WAAS device is reloaded, a syslog message and an SNMP trap are generated.

**Note**

The automatic reload feature is automatically enabled, but is not configurable on devices running WAAS Version 4.1.3 and later.

To configure a disk error-handling method using the WAAS Central Manager GUI, follow these steps:

- 
- Step 1** From the WAAS Central Manager menu, choose **Devices** > *device-name* (or **Device Groups** > *device-group-name*).
- Step 2** Choose **Configure** > **Storage** > **Disk Error Handling**.  
The Disk Error Handling Current Settings window appears.
- Step 3** The Disk Error Handling Current Settings window has two check boxes:
- Check the **Enable** check box to enable the window for configuration
  - Check the **Enable Disk Error Handling Remap**. This forces the disks to attempt to remap disk errors automatically. This is checked (enabled) by default.
- Step 4** Click **Submit** to save the settings.
- 

## Enabling Data Cache Management

The WAAS Central Manager allows you to configure existing Akamai Cache and Object Cache data partitions by increasing or decreasing the cache sizes whenever needed on the existing WAE system. Note the following scenarios with respect to WAAS devices, software version and new or subsequent Data Cache Management configuration.

### Upgrading 294,594,694 with software version 6.1.1:

When you upgrade to software version 6.1.1, and configure the device/s for data cache management for the first time and perform a reload.

All the data-cache is lost on reload.

### Upgrading vWAAS/ISR-WAAS/SM-SRE with software version 6.1.1:

When you upgrade to software version 6.1.1, and configure the device/s for data cache management for the first time and perform a reload, both data and system partitions are re-created. Logs and Data Cache are cleaned up, but software version and CM registration information is preserved.

### Fresh deployment in all models:

When you do a fresh deployment of software version 6.1.1, and configure the device/s for data cache management for the first time and perform a reload, only Akamai and object-cache data is lost.

### Second/Subsequent configuration in all models:

Configuring Data Cache Management for second/subsequent times cleans only the Akamai and Object cache partitions. All other partitions are retained.

### Limitations

The following limitations for Data Cache Management are applicable:

- If you want to configure data cache management from the WAAS Central Manager GUI, both the WAAS Central Manager and the devices registered with it need to be running version 6.1.1.

- The device needs to be in Application Accelerator mode to configure Akamai and Object Cache capability.
- The Central Manager supports mixed mode of devices in different versions. When you configure Data Cache Management at the Device level, the configurations apply only to the devices running version 6.1.1 and not to those below version 6.1.1.
- Data Cache Management is not supported on the following hardware platforms - 7541, 7571 and 8541, vWAAS 12K and vWAAS 50K.

To enable data cache management using the WAAS Central Manager GUI, follow these steps:

- 
- Step 1** From the WAAS Central Manager menu, choose **Devices** > *device-name* (or **Device Groups** > *device-group-name*).
- Step 2** Choose **Configure** > **Storage** > **Cache Size Management**.  
The Cache Size Management window appears.
- Step 3** Select from the available options.
- Default - Sets the available partition size for Akamai cache and Object cache according to predefined values.
  - Akamai-Object Cache-Equal - Sets the available partition size to 50% each, for both Akamai cache and Object cache.
  - Akamai-weight1 - Sets the partition size to 60% for Akamai cache and 40% for Object cache.
  - Akamai-weight2 - Sets the partition size to 80% for Akamai cache and 20% for Object cache.
  - ObjectCache-weight1 - Sets the partition size to 60% for Object cache and 40% for Akamai cache.
  - ObjectCache-weight2 - Sets the partition size to 80% for Object cache and 20% for Akamai cache.
- Step 4** Click **Submit** to save the settings.  
The data partition is effective only after the device is reloaded.
- To enable data cache management the CLI, use the **disk cache enable** global configuration command. If you want to view the data cache details go to **Devices** > *device-name* (or **Device Groups** > *device-group-name*) > **Monitor** > **CLI Commands** > **Show Commands** and select the **show disk cache-details** command. The cache details are displayed for devices that are running version 6.1.1.



**Note**

When you downgrade a device from 6.1.1 to any 5.x.x version, object-cache is no longer valid. As a result the associated clis are also not visible on the devices.

## Activating All Inactive WAAS Devices

To activate all the inactivated WAAS devices in your network, follow these steps:

- 
- Step 1** From the WAAS Central Manager menu, choose **Devices** > **All Devices**.  
The All Devices window appears.
- Step 2** Click the **Activate all inactive WAEs** icon in the taskbar.  
The Activate All Inactive WAEs window appears.

- Step 3** Choose an existing location for all the inactivated WAAS devices by clicking the **Select an existing location for all inactive WAEs** radio button, and then choose a location from the corresponding drop-down list.
- Alternatively, choose to create a new location for each inactive device by clicking the **Create a new location for each inactive WAE** radio button. Specify a parent location for all newly created locations by choosing a location from the **Select a parent location for all newly created locations** drop-down list.
- Step 4** Click **Submit**.
- The inactive WAEs are reactivated and placed in the specified location.
- 

## Rebooting a Device or Device Group

Using the WAAS Central Manager GUI, you can reboot a device or device group remotely.

To reboot an individual device, follow these steps:

- 
- Step 1** From the WAAS Central Manager menu, choose **Devices** > *device-name*.  
The device Dashboard appears.
- Step 2** Click the **Reload** icon in the Device Info pane.  
You are prompted to confirm your decision.
- Step 3** Click **OK** to confirm that you want to reboot the device.
- 

To reboot a device from the CLI, use the **reload EXEC** command.

If you reboot a WAAS Central Manager that has the secure store enabled with user-provided passphrase mode, you must reopen the secure store after the reboot by using the **cms secure-store open EXEC** command.

To reboot an entire device group, follow these steps:

- 
- Step 1** From the WAAS Central Manager menu, choose **Device Groups** > *device-group-name*.  
The Modifying Device Group window appears.
- Step 2** In the taskbar, click the **Reboot All Devices in Device Group** icon.  
You are prompted to confirm your decision.
- Step 3** Click **OK** to confirm that you want to reboot the device group.
-

## Performing a Controlled Shutdown

A controlled shutdown refers to the process of properly shutting down a WAAS device without turning off the power on the device (the fans continue to run and the power LED remains on). With a controlled shutdown, all of the application activities and the operating system are properly stopped on the appliance, but the power remains on. Controlled shutdowns can help you minimize the downtime when the appliance is being serviced.



---

**Caution**

If a controlled shutdown is not performed, the WAAS file system can be corrupted. It also takes longer to reboot the appliance if it was not properly shut down.

---

You can perform a controlled shutdown from the CLI by using the **shutdown** EXEC command. For more details, see the [Cisco Wide Area Application Services Command Reference Guide](#).

If you are running WAAS on a network module that is installed in a Cisco access router, perform a controlled shutdown from the router CLI by using the **service-module integrated-service-engine slot/unit shutdown** EXEC command. For more details, see the document [Configuring Cisco WAAS Network Modules for Cisco Access Routers](#).







## Monitoring Your WAAS Network

---

This chapter describes the monitoring tools available in the Cisco WAAS Central Manager GUI that can help you monitor activity, configure flow monitoring, and customize reports.

For information on Cisco WAAS system logging and troubleshooting, see Chapter 16, “[Troubleshooting Your WAAS Network](#)” and see the [Cisco WAAS Troubleshooting Guide for Release 4.1.3 and Later](#) on Cisco DocWiki.



### Note

---

Throughout this chapter, the term Cisco WAAS device is used to refer collectively to the WAAS Central Manager and Cisco Wide Area Application Engines (WAEs) in your network. The term WAE refers to WAE and Wide Area Application Virtual Engine (WAVE) appliances, Cisco Service Ready Engine Service Module (SRE-SM) modules running WAAS, and Cisco Virtual WAAS (vWAAS) instances.

---

This chapter contains the following sections:

- [Viewing System Information from the System Dashboard Window](#)
- [Viewing Device Information](#)
- [Customizing a Dashboard or Report](#)
- [WAAS Chart Descriptions](#)
- [WAAS Table Descriptions](#)
- [Using Predefined Reports to Monitor WAAS](#)
- [Managing Reports](#)
- [Configuring Flow Monitoring](#)

## Viewing System Information from the System Dashboard Window

The Cisco WAAS Central Manager GUI allows you to view general and detailed information about your Cisco WAAS network from the System Dashboard window. This section describes the System Dashboard window and contains the following topic:

- [Monitoring Graphs and Charts](#)

**Note**

For information on viewing the alarm panel and on viewing device alarms, see [WAAS Central Manager Alarm Panel](#) in Chapter 16, “Troubleshooting Your WAAS Network.”

Figure 15-1 shows the System Dashboard window.

**Figure 15-1** System Dashboard Window

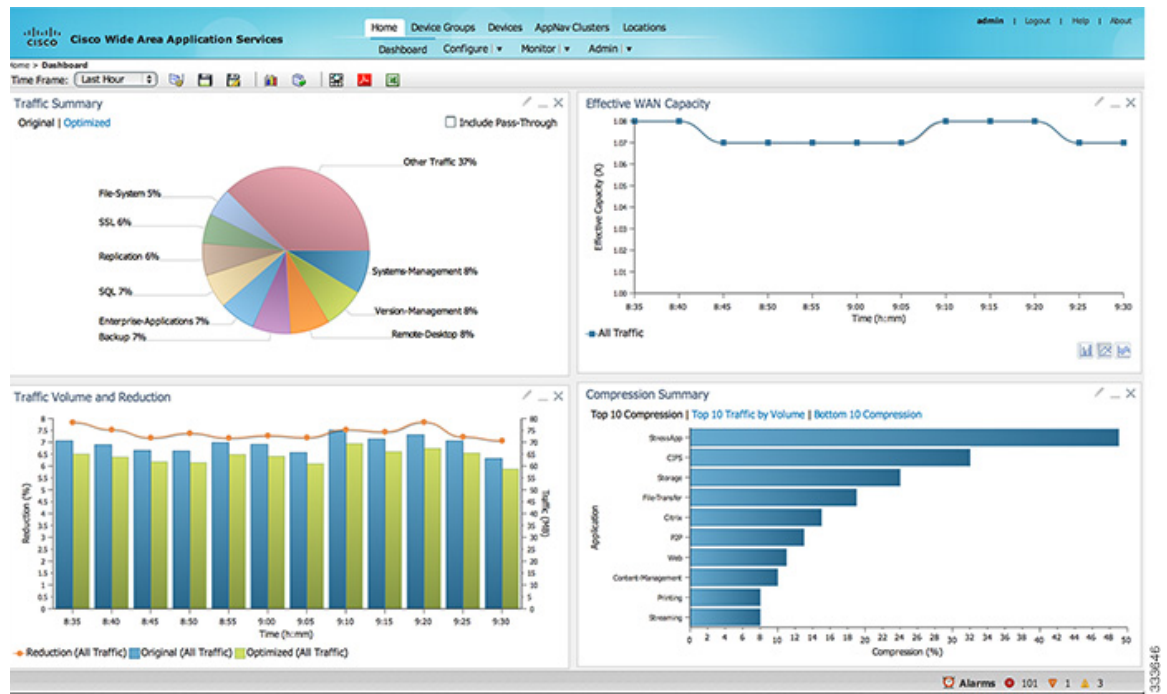

The information displayed in the charts in the System Dashboard window is based on a snapshot of your WAAS network that represents the state of your WAE devices at the end of every two polling periods. You can configure the interval between polls in the WAAS Central Manager GUI (**Configure > Global > System Properties > System.monitoring.collectRate**). The default polling rate is 300 seconds (5 minutes). Alarms are presented in real time and are independent of the polling rate.

## Monitoring Graphs and Charts

The default System Dashboard window contains the following graphical displays about the application traffic processed by your WAAS system:

- **Traffic Summary** chart—Displays the applications with the highest percentage of traffic in the WAAS network for the last hour.
- **Effective WAN Capacity** graph—Displays the effective increased bandwidth capacity of the WAN link as a result of WAAS optimization, as a multiple of the actual bandwidth.
- **Traffic Volume and Reduction** graph—Displays the original and optimized traffic volume and percentage of traffic reduction over the last hour.
- **Compression Summary** chart—Displays the ten applications with the highest percentage of traffic reduction for the WAAS network for the last hour. The percent calculation excludes pass-through traffic.

Numbers shown in charts and graphs are rounded to whole units (KB, MB, or GB), while those displayed in tables are rounded to three decimal places. Data values exported to CSV files are in bytes, and are therefore, not rounded.

You can customize the graphical displays and tables that are displayed on the system dashboard. For more information, see [Customizing a Dashboard or Report](#). Individual charts are described in more detail in [WAAS Chart Descriptions](#).

Much of the device, statistical, and alarm information that is presented in the system dashboard and associated graphs and charts is also available programmatically through the monitoring API. For more information, see [Cisco Wide Area Application Services API Reference](#).

**Note**

You must synchronize the clock on each WAE device within 5 minutes of the primary and secondary WAAS Central Managers for statistics to be consistent and reliable. For information on using an NTP server to keep all your WAAS devices synchronized, see [Configuring NTP Settings](#) in Chapter 10, “Configuring Other System Settings.” Additionally, if the network delay in the Central Manager receiving statistical updates from the WAEs is greater than 5 minutes, statistics aggregation may not operate as expected.

**Note**

For information on how to troubleshoot device alarms, see [Troubleshooting Devices Using Alerts](#) in Chapter 16, “Troubleshooting Your WAAS Network.”

## Viewing Device Information

This section describes how to use the WAAS Central Manager device windows:

- [Devices Window](#)—Displays a list of and basic information for all WAAS devices.
- [Device Dashboard Window](#)—Displays detailed information about a specific device, such as the installed software version and whether the device is online or offline.
- [Device Status Dashboard Window](#)—Displays traffic information for all WAAS devices.
- [Viewing and Unlocking Device Users](#)—Displays the list of users, in table format, with information including username, number of login failures, and time of last login failure.

## Devices Window

The Devices window lists all the WAAS devices that are registered with the WAAS Central Manager. To view this list, choose **Devices > All Devices** in the WAAS Central Manager GUI.

[Figure 15-2](#) shows an example of the Devices window.

Figure 15-2 Devices Window

| Device Name | Services                | IP Address | Management Status | Device Status | Location            | Software Version | Device Type         | Max Connections | License Status | Alarm Connect |
|-------------|-------------------------|------------|-------------------|---------------|---------------------|------------------|---------------------|-----------------|----------------|---------------|
| BA-CR11E01  | AppNav-XE Controller    | 9.2.192.1  | Online            |               | BA-CR11E01-location | 15.1(3)29.8.2    | cisco (CR11E01) NME | N/A             | Permanent      | Not Supported |
| BA-vWAAS    | Application Accelerator | 9.2.192.19 | Online            |               | BA-vWAAS-location   | 8.4.0            | OE-vWAAS-ESX        | 12600           | Enterprise     | Not Active    |
| DC-vWAAS    | Application Accelerator | 9.2.195.19 | Online            |               | DC-vWAAS-location   | 8.4.0-8ge        | OE-vWAAS-ESX        | 150             | Enterprise     | Not Active    |
| ENCS-8000   | Application Accelerator | 9.2.192.17 | Online            |               | ENCS-8000-location  | 8.4.0            | OE-ENCS             | 6000            | Enterprise     | Not Active    |
| vDM         | CM (Primary)            | 9.2.192.16 | Online            |               |                     | 8.4.0-8ge        | OE-vWAAS-ESX        | N/A             | Enterprise     | Not Supported |

This window displays the following information about each device:

- Services enabled on the device. See [Table 15-1](#) for a description of these services.
- IP address of the device.
- Management Status (Online, Offline, Pending, or Inactive). For more information about the status, see [Device Alarms](#) in Chapter 16, “Troubleshooting Your WAAS Network.”
- Device Status. The system status reporting mechanism uses four alarm lights to identify problems that have to be resolved. Each light represents a different alarm level as follows:
  - Green—No alarms (the system is in excellent health)
  - Yellow—Minor alarms
  - Orange—Major alarms
  - Red—Critical alarms

When you hover your mouse over the alarm light bar, a message provides further details about the number of alarms. Click the alarm light bar to troubleshoot the device. For more information, see [Troubleshooting Devices Using Alerts](#) in Chapter 16, “Troubleshooting Your WAAS Network.”

- Location associated with the device. For more information about locations, see [Chapter 3, “Using Device Groups and Device Locations.”](#) You can view reports that aggregate data from all the devices in a location. For more information, see [Location-Level Reports](#).
- Software version installed and running on the device. For WAAS Express and AppNav-XE devices, both the Cisco IOS and the WAAS Express or AppNav-XE software versions are shown.
- Device Type. If you see a type such as OE294, the numbers refer to the model number, such as WAVE-294. NME-WAE refers to an NME-WAE module. For WAAS Express and AppNav-XE devices, the router platform is displayed. For vWAAS devices, OE-VWAAS is displayed, and for Cisco WAAS for Cisco Integrated Services Routers (ISR) devices, ISR-WAAS is displayed.
- License Status. Displays the installed licenses. See [Table 15-2](#) for a description of the possible values.

WAE devices that are at a later software version level than the WAAS Central Manager are displayed in red. Also, if the standby WAAS Central Manager has a different version level from the primary WAAS Central Manager, the standby WAAS Central Manager is displayed in red.

You can filter your view of the devices in the list by using the Filter and Match If fields above the list. Enter a filter string in the text field and click **Go** to apply the filter. The filter settings are shown below the list. Click **Clear Filter** to clear the filter and show all the devices. Filtering allows you to find devices that match the criteria that you set.

**Table 15-1 Service Descriptions**

| Service                 | Description                                                                                    |
|-------------------------|------------------------------------------------------------------------------------------------|
| CM (Primary)            | The device has been enabled as the primary WAAS Central Manager.                               |
| CM (Standby)            | The device has been enabled as a standby WAAS Central Manager.                                 |
| Application Accelerator | The device has been enabled as an application accelerator.                                     |
| AppNav Controller       | The device has been enabled as an AppNav Controller.                                           |
| AppNav-XE Controller    | The device is a router using Cisco IOS XE with the AppNav-XE controller functionality enabled. |
| WAAS Express            | The device is a router using Cisco IOS with the WAAS Express functionality enabled.            |

**Table 15-2 License Status Descriptions**

| License Status                        | Description                                                                                                         |
|---------------------------------------|---------------------------------------------------------------------------------------------------------------------|
| Not Active                            | No license is installed, or the first configuration synchronization has not yet occurred.                           |
| Transport, Enterprise                 | The listed licenses are installed.                                                                                  |
| Active                                | A router device is registered, but the first configuration synchronization has not yet occurred.                    |
| Permanent                             | A router device has a permanent license installed.                                                                  |
| Evaluation, Expires in X weeks Y days | A router device has an evaluation license installed and it expires after the indicated period.                      |
| Expired                               | A router device has an expired evaluation license. A permanent license must be obtained for this device to operate. |
| N/A                                   | The license status is not applicable because the device version is 4.0.                                             |

**Note**

After the devices has been registered to the WAAS Central Manager (WCM), a WCM DB VACUUM (runs between 1 AM – 2 AM) process takes more time (Min:2 min, Avg:7 min, Max:25min) due to the augmented load on computing resources.

- Some of the WAEs may go temporarily offline. They are online automatically once the VACUUM process is complete.
- Statistics Aggregation threads may take more than 5 minutes and the same would be indicated in the logs. As a result statistics samples, might be missing at network level.
- User, including the administrator will not be able to use (login) the WCM as the complete DB will be locked.

## Device Dashboard Window

The Device Dashboard window provides detailed information about a WAAS device, including device model (such as WAVE-7541-K9 or OE-VWAAS-KVM), IP address, interception method, and device-specific charts. (See [Figure 15-3](#).)

To access the Device Dashboard window, choose **Devices** > *device-name*.

**Figure 15-3** Device Dashboard Window

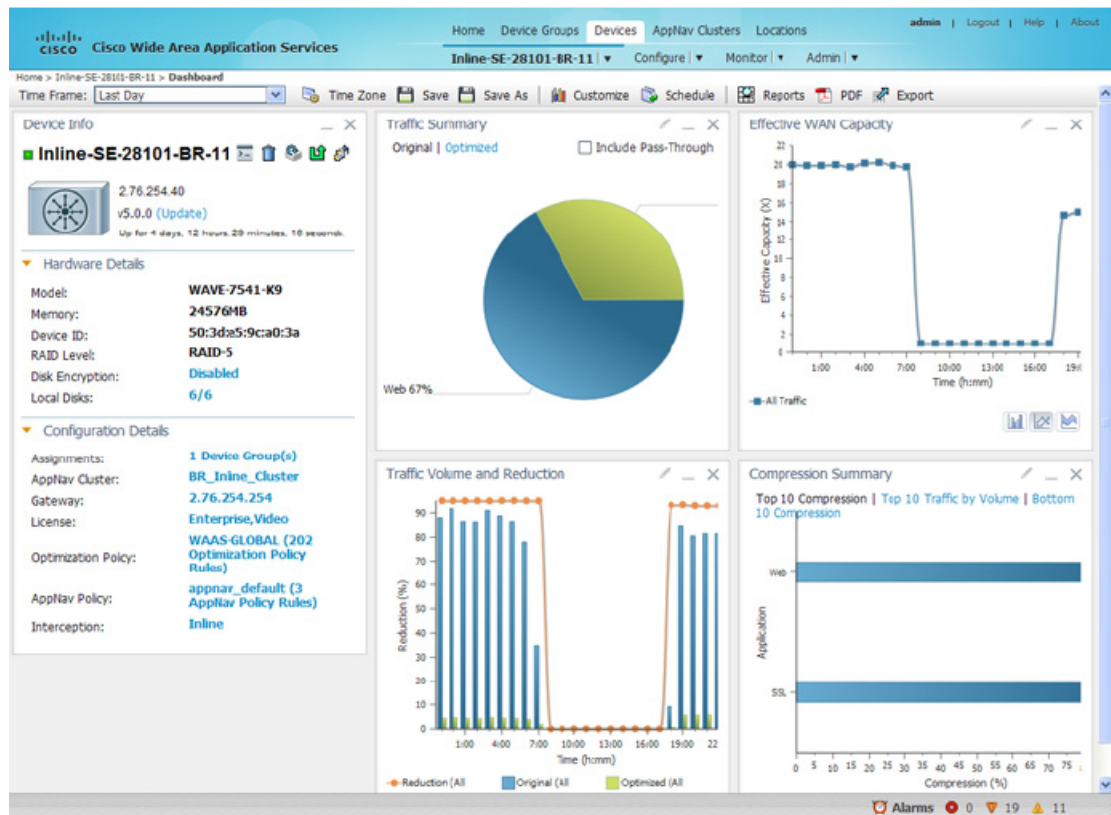

The Device Dashboard window for a WAAS Express or AppNav-XE device looks slightly different. It lacks some WAE-specific information and controls.

From the Device Dashboard window, you can perform the following tasks:

- View charts and graphs about the application traffic processed by the selected WAE device. (No charts or graphs are displayed if a WAAS Central Manager device is selected.)
- Customize the charts displayed in the window. For more information, see [Customizing a Dashboard or Report](#). Individual charts are described in more detail in [WAAS Chart Descriptions](#).
- View basic details, such as whether the device is online, the device's IP address and hostname, the software version running on the device, and the amount of memory installed in the device, the license status, and so forth.
- View the device groups to which the device belongs. For more information about device groups, see [Chapter 3, "Using Device Groups and Device Locations."](#) (Not available on AppNav-XE devices.)
- View the users that are defined on the device and unlock any locked-out users. For more information, see [Viewing and Unlocking Device Users](#). (Not available on WAAS Express and AppNav-XE devices.)
- Click the **Update** link to update the software on the device. For more information, see [Chapter 14, "Maintaining Your WAAS System."](#) (Not available on WAAS Express and AppNav-XE devices.)
- Click the **Telnet** icon to establish a Telnet session into the device and issue CLI commands.



- Click the **Delete Device** icon to delete the device.
- Click the **Full Update** icon to reapply the device configuration from the Central Manager to the device. (Not available on WAAS Express and AppNav-XE devices.)
- Click the **Reload** icon to reboot the device. (Not available on WAAS Express and AppNav-XE devices.)
- Click the **Restore Default Policies** icon to restore the default predefined policies on the device. For more information, see [Restoring Optimization Policies and Class Maps](#) in Chapter 12, “Configuring Application Acceleration.” (Not available on AppNav-XE devices.)
- Assign and unassign the device to device groups. For more information, see [Chapter 3, “Using Device Groups and Device Locations.”](#) (Not available on AppNav-XE devices.)
- For a WAAS Express device, a WAAS Enabled Interfaces item shows the number of interfaces on which WAAS optimization is enabled. You can click the number to go to the Network Interfaces configuration window, which displays device interface details and allows you to enable or disable optimization on the available interfaces. For more details, see [Enabling or Disabling Optimization on WAAS Express Interfaces](#) in Chapter 6, “Configuring Network Settings.”
- For a WAAS Express device, you can view the DRE item to determine if the device supports data redundancy elimination (DRE) optimization, which is not supported on some WAAS Express device models. This item reads Supported or Unsupported.
- For a WAAS Express device, you can view the SSL item to determine if SSL acceleration is available. This item reads Available or Unavailable.
- For a vWAAS device, the No. of CPUs, Max TCP Connections, and Interception Method fields are shown. For more details, see Chapter 5, “Configuring Traffic Interception.”
- On an AppNav Controller, an AppNav Cluster item shows any defined AppNav Clusters. You can click a cluster name to go to that cluster’s home window. Also, an AppNav Policy item shows defined AppNav policies, if any. Click a policy name to go to the policy configuration window.

## Device Status Dashboard Window

The Device Status Dashboard window, shown in [Figure 15-4](#), lists all the WAAS devices that are registered with the WAAS Central Manager. To view this list, choose **Home > Monitor > Network > Device Status** in the WAAS Central Manager GUI.

**Figure 15-4** Device Status Dashboard Window

| Device          | Management | Original Traffic | Optimized Traf. | Pass-Through | Reduction (%) | Effective Capa. | Peak Connecti. | Device Connec. | Total Active C... |
|-----------------|------------|------------------|-----------------|--------------|---------------|-----------------|----------------|----------------|-------------------|
| AAA-BR2-SM-710  | Online     | 871.809 KB       | 0 Bytes         | 1.095 MB     | 100           | 1000.0          | 0              | 500            | 0                 |
| AAA-DC2-594-2-a | Online     | 10.298 MB        | 10.941 MB       | 2.393 MB     | 0             | 1.0             | 1              | 750            | 3                 |
| AAA-POD7-ER-39  | Online     | 0 Bytes          | 0 Bytes         | N/A          | 0             | 1.0             | 0              | 200            | 0                 |
| AAA-POD7-ER-39  | Online     | 0 Bytes          | 0 Bytes         | N/A          | 0             | 1.0             | 0              | 0              | 0                 |
| BR-SM-750       | Online     | 954.563 KB       | 7.766 KB        | 61.614 KB    | 99.19         | 123.46          | 1              | 750            | 12                |
| CPARH-VIAASK-C  | Online     | 9.730 GB         | 161.437 MB      | N/A          | 98.38         | 61.73           | 158            | 250            | 1311              |
| CPARH-VIAE-594  | Online     | 10.479 GB        | 1.269 GB        | 358.739 MB   | 87.89         | 8.26            | 251            | 750            | 1901              |
| DC-SMB-WAE-2>   | Online     | 0 Bytes          | 0 Bytes         | 0 Bytes      | 0             | 1.0             | 0              | 200            | 0                 |
| Galaxy-Han-DC-B | Offline    | 0 Bytes          | 0 Bytes         | 0 Bytes      | 0             | 1.0             | 0              | 150000         | 0                 |
| Galaxy-Han-ESSE | Offline    | 0 Bytes          | 0 Bytes         | 0 Bytes      | 0             | 1.0             | 0              | 6000           | 0                 |
| MSP1-POD48-DCc  | Offline    | 0 Bytes          | 0 Bytes         | 0 Bytes      | 0             | 1.0             | 0              | 0              | 0                 |
| MSP1BR-594      | Online     | 67.543 MB        | 69.488 MB       | 711.960 KB   | 0             | 1.0             | 225            | 750            | 2564              |

[Table 15-3](#) displays information about each column in the Device Status Dashboard window:

**Table 15-3** Column and Field Descriptions for the Device Status Dashboard Window

| Device Status Field or Column | Device Status Column Description                                                                                                                                                                                                                                                                                                                                                                                                                                                                                                                  |
|-------------------------------|---------------------------------------------------------------------------------------------------------------------------------------------------------------------------------------------------------------------------------------------------------------------------------------------------------------------------------------------------------------------------------------------------------------------------------------------------------------------------------------------------------------------------------------------------|
| Time Frame drop-down list     | <p>Choose one of the following time frame to display status for the device:</p> <ul style="list-style-type: none"> <li>• Last Hour</li> <li>• Last Day</li> <li>• Last Week</li> <li>• Last Month</li> <li>• Custom dates</li> </ul> <p> <b>Note</b> Data for Management Status and Active Connections is displayed only when you select <b>Last Hour</b>.</p> <p>For more information on time frames, see <a href="#">Customizing a Dashboard or Report</a></p> |
| Device                        | The name of the device.                                                                                                                                                                                                                                                                                                                                                                                                                                                                                                                           |
| Management Status             | A status of Online, Offline, Pending, or Inactive. For more information on device management status and alarms related to device management status, see <a href="#">Device Alarms</a> in Chapter 16, “Troubleshooting Your WAAS Network.”                                                                                                                                                                                                                                                                                                         |
| Original Traffic              | The amount of original traffic, in GB, passing through the device.                                                                                                                                                                                                                                                                                                                                                                                                                                                                                |
| Optimized Traffic             | The amount of optimized traffic, in GB, passing through the device.                                                                                                                                                                                                                                                                                                                                                                                                                                                                               |
| Pass-Through Reduction (%)    | The percentage of traffic reduction for the time period specified in the Time Frame drop-down list.                                                                                                                                                                                                                                                                                                                                                                                                                                               |
| Effective Capacity (X)        | The effective bandwidth capacity of the device as a result of optimization.                                                                                                                                                                                                                                                                                                                                                                                                                                                                       |
| Peak Connection               | The peak optimized connections for the device.                                                                                                                                                                                                                                                                                                                                                                                                                                                                                                    |
| Device Connection Limit       | The maximum connection limit for the device.                                                                                                                                                                                                                                                                                                                                                                                                                                                                                                      |
| Total Active Connections      | The total number of current active connections for the device.                                                                                                                                                                                                                                                                                                                                                                                                                                                                                    |

## Device Status Report

You can choose to view the Device Status report as a pdf or a .csv file by selecting the respective icons on the dashboard. The Time Zone option enables you to customize the time zone for the report, based on your preference. For more information on setting time zones, see [Customizing a Dashboard or Report](#).

You can filter your view of the devices in the list by using the Filter and Match If fields above the list. Enter a filter string in the text field and click the Go button to apply the filter. The filter settings are shown below the list. Click the Clear Filter button to clear the filter and show all devices. Filtering allows you to find devices in the list that match the criteria that you set.



## Viewing and Unlocking Device Users

To view the users defined on a WAAS device, go to **Devices** > *device-name*, and then, from the *device-name* menu, choose **Device Users**. On a Central Manager device, choose **CM Users**).

The list of users is displayed in a table, which shows the username, number of login failures, maximum number of login failures allowed, and the time of the last failed login. To view the details of a user, click the **View** icon next to that username.

If a user is locked out because the user has reached the maximum number of failed login attempts, unlock the user by checking the check box next to the username and clicking **Unlock** below the table.

## Customizing a Dashboard or Report

You can customize the system and device dashboards and reports, if any, in the same way. For more information about creating custom reports, see [Managing Reports](#).

This section contains the following topics:

- [The WAAS Central Manager Report Panel](#)
- [Adding a Chart or Table](#)
- [Configuring Chart Settings](#)

## The WAAS Central Manager Report Panel

An example of a report is shown in [Figure 15-5](#).

**Figure 15-5** Report Pane

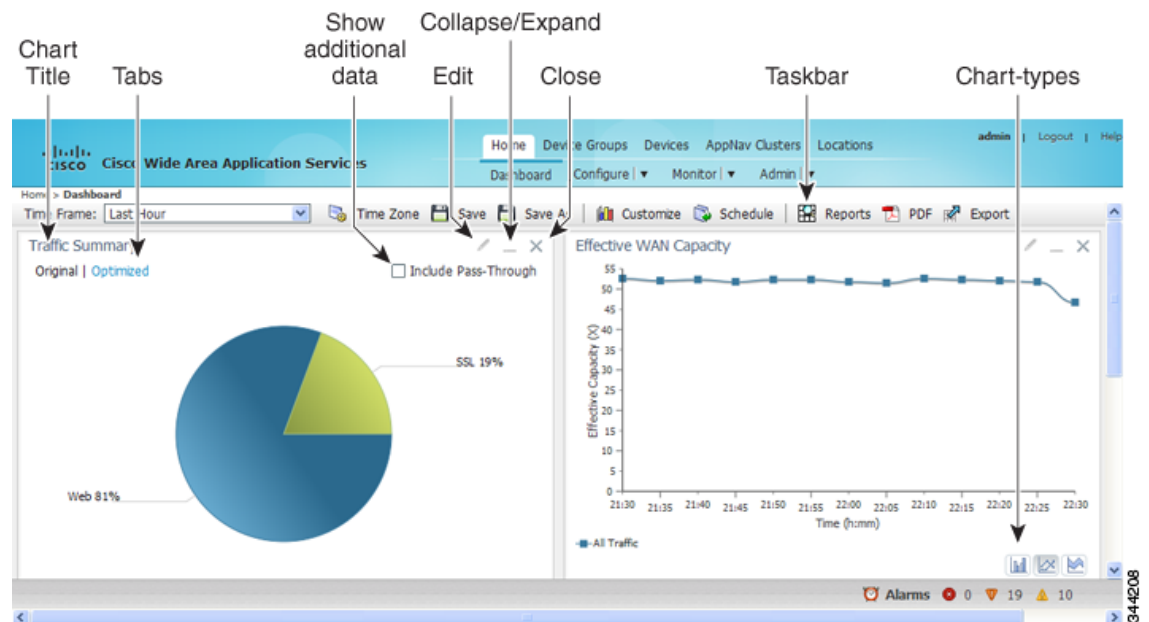

Taskbar icons and controls across the top of the dashboard or report allow you to do the following:

- **Time Frame**—Allows you to choose one of the several common time frames from the drop-down list:
  - **Last Hour**—Displays data for the past hour, in five-minute intervals (default). You can change the interval using the `System.monitoring.collectRate` configuration setting described in [Modifying the Default System Configuration Properties](#) in Chapter 10, “Configuring Other System Settings.”
  - **Last Day**—Displays data for the past day (in hourly intervals).
  - **Last Week**—Displays data for the past week (in daily intervals).
  - **Last Month**—Displays data for the past month (in daily intervals).
  - **Custom**—Enter starting and ending dates in the From and To fields. Click the calendar icon to choose dates from a pop-up calendar.

The time frame setting is stored individually for each report and Central Manager user. Additionally, the `System.monitoring.timeFrameSettings` system property controls the system default time frame setting (see [Modifying the Default System Configuration Properties](#) in Chapter 10, “Configuring Other System Settings”).

**Note**

---

If you create a chart with a custom date setting that spans more than two months prior to the current date, data for the most recent two months are plotted with daily data and data for all the earlier months are plotted with aggregated monthly data. The chart might appear to have a large drop in traffic for the most recent two months because the daily traffic totals are likely to be much smaller than the monthly traffic totals. However, this difference is normal.

---

- **Time Zone**—Allows you to choose one of the following options from the Time Zone drop-down list:
  - **UTC**—Sets the time zone of the report to UTC.
  - **CM Local Time**—Sets the time zone of the report to the time zone of the WAAS Central Manager (default).

When you change the time zone, the change applies globally to all reports. The time zone setting is stored individually for each Central Manager user.

- **Save**—Saves the dashboard or report with its current settings. The next time you view it, it is displayed with these settings.
- **Save As**—Saves the report with its current settings under a new name. A dialog box allows you to enter a report name and an optional description. You can enter only the following characters: numbers, letters, spaces, periods, hyphens, and underscores. The report will be available in the **Monitor > Reports > Reports Central** window.
- **Customize**—Allows you to add a chart or table to a dashboard or report. For information on adding a chart or table, see [Adding a Chart or Table](#).
- **Schedule**—Allows you to schedule reports to be generated once, or periodically, such as hourly, daily, weekly, or monthly. When a scheduled report is generated, you can have a PDF copy of the report e-mailed to you automatically.
  - In the Date field, enter the schedule date in the format DD/MM/YYYY or click the calendar icon to display a calendar from which to choose the date.
  - From the Hours drop-down list, choose the hours. The time represents the local time at the WAAS Central Manager.
  - From the Minutes drop-down list, choose the minutes. The time represents the local time at the WAAS Central Manager.

- From the Frequency drop-down list, choose **Once**, **Hourly**, **Daily**, **Weekly**, or **Monthly** for the report frequency.
- In the No. of Reports field, enter the number of times that a reoccurring report is to be generated. (After a report is generated a specified number of times, the report is no longer generated.)
- In the Email Id(s) field, enter the email addresses of the report recipients, separated by commas.
- In the Email Subject field, enter the subject of the email message.
- Reports—Allows you to view the scheduled reports. For instructions about viewing scheduled reports, see [Viewing or Deleting a Scheduled Report](#).
- PDF—Generates a PDF format of a report, including the charts and table data. If you want a custom logo in your PDF report, you can upload the logo by choosing **Home Dashboard**> **Admin**> **Custom Logo**, and clicking **Upload**. The custom logo is displayed in the PDF format of the report. Additionally, when you schedule a report, you can select **Custom Logo** for the logo to appear on the scheduled report. This option is available only when you have uploaded the custom logo.
- Export—Exports the chart and table statistical data to a CSV file. The statistical data shown in charts is rounded to whole units (KB, MB, or GB), while the exported data contains exact byte values.

Controls at the top of individual charts allow you to customize the chart as follows (not all controls are available in every chart):

- Chart title—Allows you to click and drag in order to move the chart to a different location in the report pane.
- Edit icon—Allows you to edit the chart settings, as described in [Configuring Chart Settings](#).
- Collapse/Expand icon—Allows you to collapse or expand the chart. When a chart is collapsed, this icon changes to Expand, which restores the chart to its normal size.
- Close icon—Closes the chart.
- Tabs—Allows you to have a choice of multiple tab views that you can access by clicking the desired tab name. Note that not all charts have this feature.
- Check box to show additional data—Allows you to check the check box labeled with an optional data statistic to include the data in the chart. Note that not all charts have this feature.

Chart-type icons at the bottom of individual charts allow you to choose the chart type as follows: column chart, line chart, area chart, stacked line chart, stacked area chart. Note that not all charts have this feature.

## Adding a Chart or Table

To add a chart or table to a dashboard or report, follow these steps:

- 
- Step 1** From the dashboard or report chart panel, click the **Customize** icon in the taskbar. The Customize window is displayed, as shown in [Figure 15-6](#).

Figure 15-6 Customize Window

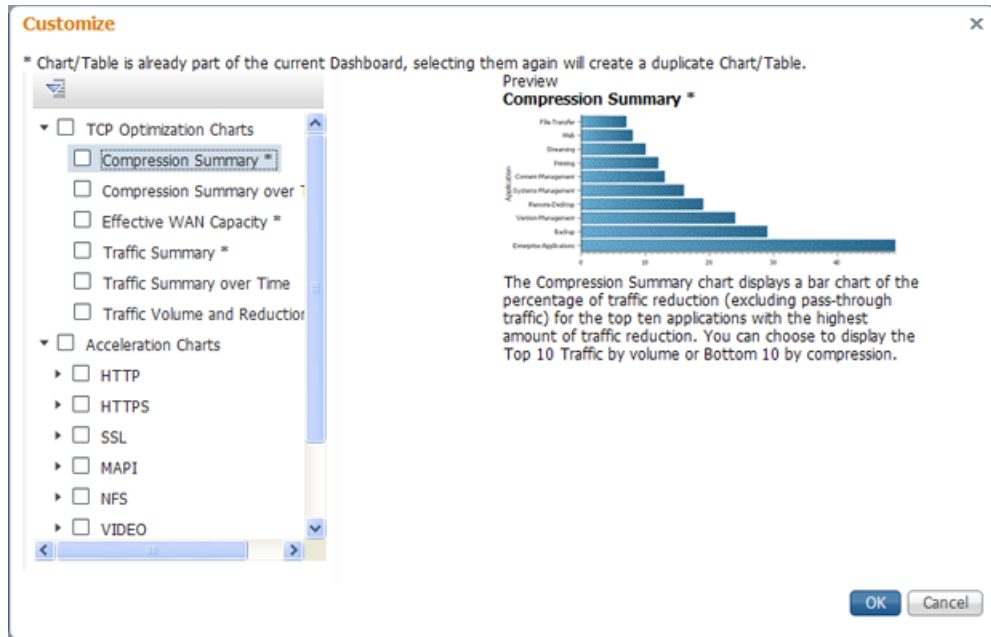

**Step 2** Expand any of the chart categories by clicking on the small triangle next to the corresponding category.

**Step 3** Check the check box next to each chart or table that you want to be displayed as a report. Individual charts are described in more detail in [WAAS Chart Descriptions](#).

Charts that are currently included in the dashboard or report are marked with an asterisk (\*). A report can contain a maximum of eight charts and tables (the Network Summary report can contain 12 charts and tables).



**Note** At the WAAS Express device level, only charts for supported accelerators are available.

**Step 4** To preview a chart, click the chart's title. The preview is displayed on the right of the pane.

**Step 5** Click **OK**.

To delete a chart or table from a dashboard or report, click **Close** on the chart and save the report.

## Configuring Chart Settings

To configure the data presented in a chart, follow these steps:

**Step 1** Click the **Edit** icon in the upper right corner of a chart. The Settings window is displayed.



**Note** Not all settings are available for all chart types.

**Step 2** (Optional) From the Traffic Direction drop-down list, choose one of the following options:

- **Bidirectional**—Includes LAN-to-WAN traffic as well as WAN-to-LAN traffic traveling through this WAAS device.
- **Inbound**—Includes traffic from the WAN to the client through this WAAS device.
- **Outbound**—Includes traffic traveling from a client to the WAN through this WAAS device.

**Step 3** (Optional) From the Access Mode drop-down list, choose one of the following options:

- **Both**—Displays statistics for both single-sided and double-sided optimization.
- **With WAAS Peer**—Display statistics for double-sided optimization.
- **Without WAAS Peer**—Displays statistics for single-sided optimization.

Use these options to include or exclude single-sided optimization. The single-side statistics option is available only for the Traffic Summary, Effective WAN capacity, Traffic Volume and Reduction, Compression Summary, Traffic Summary over time, Compression Summary over time, Throughput Summary and Optimized Connections Over Time charts.

**Step 4** (Optional) From the Select Series For drop-down list, choose one of the following:

- **Application**—The chart data is based on application statistics.
- **Classifier**—The chart data is based on classifier (class map) statistics.

**Step 5** (Optional) In the **Application** or **Classifier** list, check the check box next to the applications or classifiers whose statistics you want to include in the chart data. To include all the applications, check the **All Traffic** check box. You can filter the list items by using the Quick Filter above the list. These lists are available only for some chart types.

**Step 6** (Optional) Some charts have other types of data series from which to choose. Check the check box next to each of the data series that you want to include in the chart data.

**Step 7** Click **OK**.

**Note**

Data collection for applications and classifiers occurs at slightly different times in the Central Manager. Therefore, the statistics can be different when viewing the same time period for an application and a classifier that report similar data.

## WAAS Chart Descriptions

This section describes the charts that you can choose to include in a dashboard or report. For tables that provide information on system, device, traffic and acceleration, see [WAAS Table Descriptions](#),

The following chart categories are available:

- [TCP Optimization Charts](#)
- [Acceleration Charts](#)
- [Akamai Connected Cache Charts](#)
- [Connection Trend Charts](#)
- [AppNav Charts](#)
- [Platform Charts](#)

All charts are created using the Central Manager local time zone, unless the chart settings are customized to use a different time zone.

**Note**

At the device level for WAAS Express devices, only charts for supported accelerators are available. In all charts, pass-through traffic for WAAS Express devices is considered as zero.

## TCP Optimization Charts

The following TCP optimization charts are available:

- [Compression Summary](#)
- [Compression Summary Over Time](#)
- [Effective WAN Capacity](#)
- [Throughput Summary](#)
- [Traffic Summary](#)
- [Traffic Summary Over Time](#)
- [Traffic Volume and Reduction](#)

### Compression Summary

The Compression Summary chart displays a bar chart depicting the percentage of traffic reduction (excluding pass-through traffic) for the top ten applications with the highest percentage of traffic reduction. Two additional tabs allow you to see the compression of the top ten applications by volume and the bottom ten applications with the lowest compression.

**Formula:**

$$\% \text{ Reduction Excluding Pass-Through} = (\text{Original Excluding Pass-Through} - \text{Optimized}) / (\text{Original Excluding Pass-Through})$$

### Compression Summary Over Time

The Compression Summary Over Time chart displays a graph of the percentage of total traffic that was reduced by using the WAAS optimization techniques. This chart excludes pass-through traffic in the results. You can customize the chart by choosing specific applications to include. The default is all traffic.

**Formula:**

$$\% \text{ Reduction} = (\text{Original Excluding Pass-Through} - \text{Optimized}) / (\text{Original Excluding Pass-Through})$$

### Effective WAN Capacity

The Effective WAN Capacity chart displays the effective increased bandwidth capacity of the WAN link as a result of WAAS optimization. You can choose which applications to include. The default is all traffic.

**Formula:**

Effective WAN Capacity =  $1 / (1 - \% \text{ Reduction Excluding Pass-Through})$

$\% \text{ Reduction Excluding Pass-Through} = (\text{Original Excluding Pass-Through} - \text{Optimized}) / (\text{Original Excluding Pass-Through})$

## Throughput Summary

The Throughput Summary chart displays the amount of average and peak throughput for the LAN-to-WAN (outbound) or WAN-to-LAN (inbound) directions depending on the selected tab. The throughput units (KBps, MBps, or GBps) at the left side vary depending on the range. The Peak Throughput series is not applicable for Last Hour graphs. This chart is available only at the device and location levels. The chart, which is in PDF, displays a maximum of 10 series.

**Formula:**

$\% \text{ Reduction Excluding Pass-Through} = (\text{Original Excluding Pass-Through} - \text{Optimized}) / (\text{Original Excluding Pass-Through})$

**Note**

The WAN to LAN Throughput and the LAN to WAN Throughput charts for the Last Week and Last Month time periods do not display peak throughput data until after two days of data have accumulated. You may see 0 for peak throughput if it has been less than two days since a new WAAS software installation or upgrade.

## Traffic Summary

The Traffic Summary chart displays the top nine applications that have the highest percentage of traffic as seen by WAAS. Each section in the pie chart represents an application as a percentage of the total traffic on your network or device. Unclassified, unmonitored, and applications with less than 2 percent of the total traffic are grouped together into a tenth category named Other Traffic (shown only if it totals at least 0.1 percent of all traffic). You can choose to display Original traffic or Optimized traffic by clicking the tab, and you can include pass-through traffic by checking the **Include Pass-Through** check box.

**Formula:**

$(\text{App Traffic} / \text{Total Traffic}) * 100$

App Traffic is the Original traffic (Original Excluding Pass-Through) or Optimized traffic (Optimized Excluding Pass-Through) flowing for an application.

## Traffic Summary Over Time

The Traffic Summary Over Time chart displays a graph depicting the amount of original or optimized traffic, depending on the selected tab. You can include pass-through traffic by checking the **Pass-Through** check box. You can customize the chart by choosing specific applications to include. The default is all traffic.

## Traffic Volume and Reduction

The Traffic Volume and Reduction chart compares the amount of original and optimized traffic in a bar chart and displays the percentage of traffic reduction as a line. Pass-through traffic is excluded. The traffic units (bytes, KB, MB, or GB) at the right side depend upon the range. The percentage of traffic reduction is shown at the left side of the chart. You can customize the chart by choosing specific applications to include. The default is all traffic.

**Formula:**

$$\% \text{ Reduction Excluding Pass-Through} = (\text{Original Excluding Pass-Through} - \text{Optimized}) / (\text{Original Excluding Pass-Through})$$

## Acceleration Charts

This section describes these charts:

- [HTTP Acceleration Charts](#)
- [HTTPS Acceleration Charts](#)
- [Secure Sockets Layer \(SSL\) Acceleration Charts](#)
- [Messaging Application Programming Interface \(MAPI\) Acceleration Charts](#)
- [Network File System \(NFS\) Acceleration Charts](#)
- [Server Message Block \(SMB\) Acceleration Charts](#)
- [Independent Computing Architecture \(ICA\) Acceleration Charts](#)

## HTTP Acceleration Charts

This section describes these charts:

- [HTTP: Connection Details](#)
- [HTTP: Effective WAN Capacity](#)
- [HTTP: Estimated Time Savings](#)
- [HTTP: Optimization Count](#)
- [HTTP: Optimization Techniques](#)
- [HTTP: Response Time Savings](#)

### HTTP: Connection Details

The HTTP Connection Details chart displays the HTTP session connection statistics, showing the average number of active HTTP connections per device (at the device level, it shows the exact number for the last hour.) Click the **Details** tab to display the newly handled HTTP connections, optimized connections, dropped connections, and handed off connections over time.

### HTTP: Effective WAN Capacity

The HTTP Effective WAN Capacity chart displays the effective bandwidth capacity of the WAN link as a result of HTTP acceleration, as a multiplier of its base capacity. The capacity data for all traffic and HTTP traffic is shown.



**Note**

If the chart has no data, monitoring may be disabled for the application definition that includes this type of traffic. Verify that monitoring is enabled for the web application.

### HTTP: Estimated Time Savings

The HTTP Estimated Time Savings chart displays a graph of the estimated percentage of the response time saved by the HTTP accelerator due to SharePoint prefetch optimization and metadata caching.

### HTTP: Optimization Count

The HTTP Optimization Count chart displays a graph of the number of different kinds of optimizations performed by the HTTP accelerator. These optimizations are displayed in different colors. The optimizations included in this chart are metadata caching and SharePoint prefetch.

### HTTP: Optimization Techniques

The HTTP Optimization Techniques pie chart displays the different kinds of optimizations performed by the HTTP accelerator. The optimizations included in this chart are metadata caching, suppressed server compression, SharePoint prefetch, and DRE hinting.

### HTTP: Response Time Savings

The HTTP Response Time Savings chart displays a graph of the round-trip response time saved by the HTTP accelerator due to metadata caching and SharePoint prefetch optimizations. These optimizations are displayed in different colors. The time units (milliseconds, seconds, or minutes) at the left side depend on the range.

## HTTPS Acceleration Charts

This section describes the following charts:

- [HTTPS: Connection Details](#)
- [HTTPS: Effective WAN Capacity](#)
- [HTTPS: Estimated Time Savings](#)
- [HTTPS: Optimization Count](#)
- [HTTPS: Optimization Techniques](#)
- [HTTPS: Response Time Savings](#)

### HTTPS: Connection Details

The HTTPS Connection Details chart displays the HTTPS session connection statistics, showing the average number of active HTTPS connections per device (at the device level, it shows the exact number for the last hour). Click the **Details** tab to display the newly handled HTTPS connections and optimized connections.

### HTTPS: Effective WAN Capacity

The HTTPS Effective WAN Capacity chart displays the effective bandwidth capacity of the WAN link as a result of HTTP acceleration, as a multiplier of its base capacity. The capacity data for all traffic and SSL traffic (which includes HTTPS traffic) is shown.



#### Note

If the chart has no data, monitoring may be disabled for the application definition that includes this type of traffic. Make sure that monitoring is enabled for the SSL application.

### HTTPS: Estimated Time Savings

The HTTPS Estimated Time Savings chart displays the estimated percentage of response time saved by using metadata caching for HTTPS connections.

### HTTPS: Optimization Count

The HTTPS Optimization Count chart displays a graph of the number of different kinds of metadata caching optimizations performed by the HTTPS accelerator. These optimizations are displayed in different colors.

### HTTPS: Optimization Techniques

The HTTPS Optimization Techniques pie chart displays the different kinds of optimizations performed by the HTTPS accelerator. The optimizations included in this chart are metadata caching, suppressed server compression, and DRE hinting.

### HTTPS: Response Time Savings

The HTTPS Response Time Savings chart displays a graph of the round-trip response time saved by the HTTPS accelerator due to metadata caching optimizations, which are displayed in different colors. The time units (milliseconds, seconds, or minutes) at the left side depend on the range.

## Secure Sockets Layer (SSL) Acceleration Charts

This section describes these charts:

- [SSL: Acceleration Bypass Reason](#)
- [SSL: Connection Details](#)
- [SSL: Effective WAN Capacity](#)

### SSL: Acceleration Bypass Reason

The Secure Sockets Layer (SSL) Acceleration Bypass Reason pie chart displays the reasons because of which SSL traffic is not accelerated: version mismatch, unknown, nonmatching domain, server name indication mismatch, cipher mismatch, revocation failure, certificate verification failure, other failure, and non-SSL traffic.

### SSL: Connection Details

The SSL Connection Details chart displays the SSL session connection statistics, showing the average number of active SSL connections per device (at the device level, it shows the exact number for the last hour). Click the **Details** tab to display the newly handled SSL connections, optimized connections, handed-off connections, dropped connections, HTTPS connections, and Independent Computing Architecture (ICA) connections over SSL.

### SSL: Effective WAN Capacity

The SSL Effective WAN Capacity chart displays the effective bandwidth capacity of the WAN link as a result of SSL acceleration, as a multiplier of its base capacity. The capacity data for all traffic and SSL traffic is shown.

**Note**

---

If the chart has no data, monitoring may be disabled for the application definition that includes this type of traffic. Verify that monitoring is enabled for the SSL application.

---

## Messaging Application Programming Interface (MAPI) Acceleration Charts

This section describes these charts:

- [MAPI: Acceleration Bypass Reason](#)
- [MAPI: Average Response Time Saved](#)
- [MAPI: Connection Details](#)
- [MAPI: Effective WAN Capacity](#)
- [MAPI: Request Optimization](#)
- [MAPI: Response Time Optimization](#)
- [MAPI: Average Accelerated Client Sessions](#)
- [MAPI: Handled Traffic Pattern](#)
- [MAPI: Connection Details](#)

### MAPI: Acceleration Bypass Reason

The Messaging Application Programming Interface (MAPI) Acceleration Bypass Reason pie chart displays the reasons because of which encrypted MAPI traffic is not accelerated: acceleration disabled, secret retriever disabled, unsupported cipher, unsupported authentication mechanism, misconfigured domain identity, failure in secret retrieval, general security failure, insufficient system resources, and recovery mode connections.

Click the **Non-Encrypted** tab to display the bypass reasons for unencrypted MAPI traffic: reservation failure (non-overload), reservation failure (overload), signed MAPI request, malformed RPC packet, handover request from peer, unsupported server version, user in denied list, unsupported client version, secured connections (encrypted), unsupported DCERPC protocol version, association group not tracked, and other.

### MAPI: Average Response Time Saved

The MAPI Average Response Time Saved chart displays a graph of the estimated percentage of response time saved by the MAPI accelerator. The time units (microseconds, milliseconds, seconds, or minutes) at the left side depend upon the range.

### MAPI: Connection Details

The MAPI Connection Details chart displays the MAPI session connection statistics, showing the average number of active MAPI connections per device (at the device level, it shows the exact number for the last hour). Click the **Details** tab to display the newly handled MAPI connections, optimized connections, handed-off connections, and dropped connections. Click the **Optimized Encrypted vs Non-Encrypted** tab to display the new encrypted and unencrypted MAPI connections.

### MAPI: Effective WAN Capacity

The MAPI Effective WAN Capacity chart displays the effective bandwidth capacity of the WAN link as a result of MAPI acceleration, as a multiplier of its base capacity. The capacity data for all traffic and MAPI traffic is shown.



#### Note

If the chart has no data, monitoring may be disabled for the application definition that includes this type of traffic. Verify that monitoring is enabled for the Email-and-Messaging application.

### MAPI: Request Optimization

The MAPI Request Optimization chart displays the percentage of local and remote MAPI command responses. A local response is a response that is sent to the client from the local WAE. A remote response comes from the remote server. Click the **Encrypted vs Non-Encrypted** tab to display the percentage of local and remote responses for encrypted and unencrypted MAPI connections.

### MAPI: Response Time Optimization

The MAPI Response Time Optimization chart compares the average time used for local and remote MAPI responses. The time units (microseconds, milliseconds, seconds, or minutes) at the left side depend upon the range. Click the **Encrypted vs Non-Encrypted** tab to display the average time used for local and remote responses for encrypted and unencrypted MAPI connections.

### MAPI: Average Accelerated Client Sessions

The MAPI Average Accelerated Client Sessions pie chart displays the average number of encrypted sessions that are accelerated from different versions (2000, 2003, 2007, and 2010) of the Microsoft Outlook client. Click the **Non-Encrypted** tab to display the unencrypted session counts.

### MAPI: Handled Traffic Pattern

For WAAS Versions 5.5.3 and later, MAPI Acceleration reports include the MAPI: Handled Traffic Pattern pie chart. As shown in [Figure 15-7](#), this chart displays the percentage of three types of traffic:

- Total handled MAPI connections
- Total handled MAPI RPC-HTTP connections
- Total handled MAPI RPC-HTTPS connections

**Figure 15-7 Example of MAPI: Handled Traffic Pattern Chart**

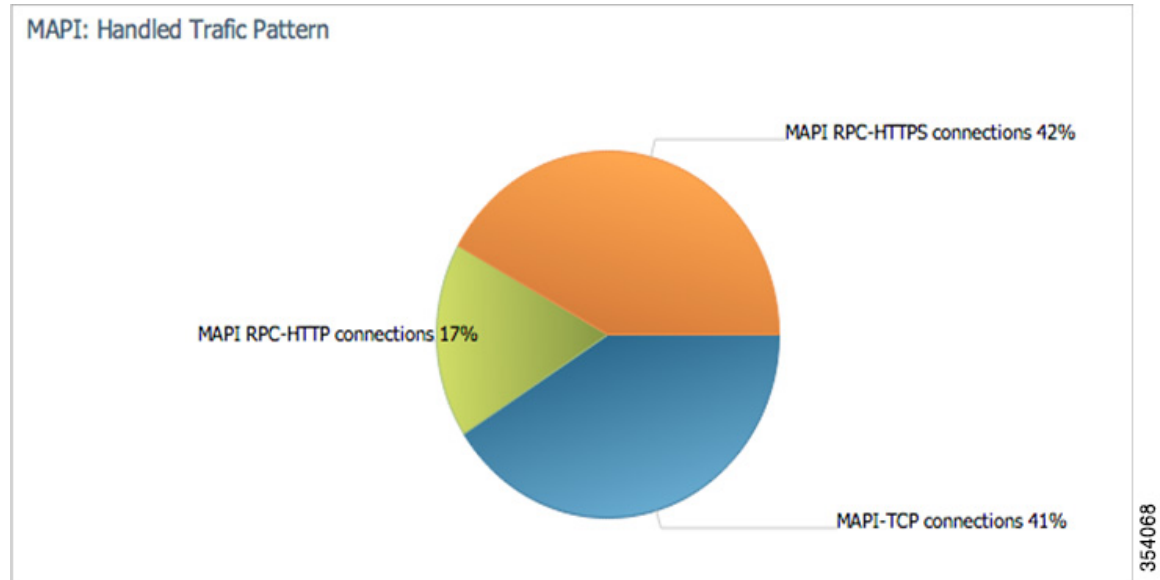

354068

**MAPI: Connection Details**

The MAPI Connection Details chart displays MAPI session connection statistics, showing the average number of active MAPI connections per device (at the device level, it shows the exact number for the last hour). In addition to information on newly handled MAPI connections, optimized connections, handed-off connections, dropped connections, and optimized vs. non-encrypted MAPI connections, WAAS Version 5.5.3 and later also provides information on optimized TCP vs. RPC-HTTP(S) MAPI connections, as shown in Figure 15-8.

**Figure 15-8 Example of MAPI: Connection Details Chart**

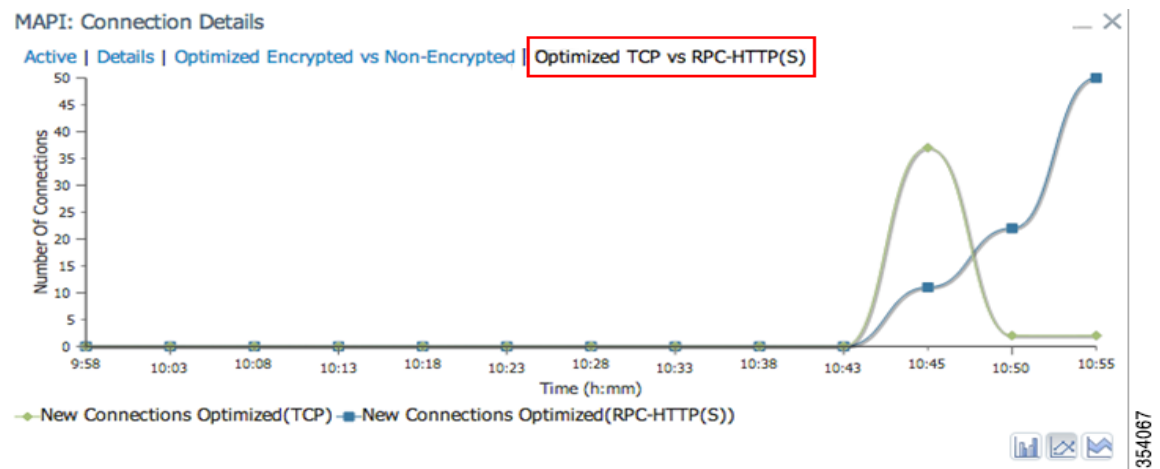

354067

## Network File System (NFS) Acceleration Charts

This section describes these charts:

- [NFS: Acceleration Bypass Reason](#)
- [NFS: Connection Details](#)
- [NFS: Effective WAN Capacity](#)
- [NFS: Estimated Time Savings](#)
- [NFS: Request Optimization](#)
- [NFS: Response Time Optimization](#)
- [NFS: Versions Detected](#)

### NFS: Acceleration Bypass Reason

The Network File System (NFS) Acceleration Bypass Reason pie chart displays the reasons because of which NFS traffic is not accelerated: unknown authentication flavor or unknown NFS version.

### NFS: Connection Details

The NFS Connection Details chart displays the NFS session connection statistics, showing the average number of active NFS connections per device (at the device level, it shows the exact number for the last hour). Click the **Details** tab to display the newly handled NFS connections, optimized connections, handed-off connections, and dropped connections.

### NFS: Effective WAN Capacity

The NFS Effective WAN Capacity chart displays the effective bandwidth capacity of the WAN link as a result of NFS acceleration, as a multiplier of its base capacity. The capacity data for all traffic and NFS traffic is shown.



#### Note

If the chart has no data, monitoring may be disabled for the application definition that includes this type of traffic. Verify that monitoring is enabled for the File-System application.

### NFS: Estimated Time Savings

The NFS Estimated Time Savings chart displays a graph of the estimated percentage of response time saved by the NFS accelerator.

### NFS: Request Optimization

The NFS Request Optimization chart displays the percentage of local and remote NFS command responses. A local response is a response that is sent to the client from the local WAE. A remote response comes from the remote server.

### NFS: Response Time Optimization

The NFS Response Time Optimization chart compares the average time used for local and remote NFS responses. The time units (milliseconds, seconds, or minutes) at the left side depend upon the range.

## NFS: Versions Detected

The NFS Versions Detected pie chart displays the number of NFS messages detected for each NFS version (2, 3, and 4). The NFS accelerator works with NFS Version 3 traffic.

## Server Message Block (SMB) Acceleration Charts

This section describes these charts:

- [SMB: Average Response Time Saved](#)
- [SMB: Client Average Throughput](#)
- [SMB: Connection Details](#)
- [SMB: Effective WAN Capacity](#)
- [SMB: Request Optimization](#)
- [SMB: Response Time Savings](#)
- [SMB: Versions Detected](#)

### SMB: Average Response Time Saved

The Server Message Block (SMB) Average Response Time Saved chart displays the average response time saved for SMB responses. The time units (milliseconds, seconds, or minutes) at the left side depend upon the range.

### SMB: Client Average Throughput

The SMB Client Average Throughput chart displays the average client throughput for the SMB accelerator.

### SMB: Connection Details

The SMB Connection Details chart displays the SMB session connection statistics, showing the average number of active SMB connections per device (at the device level, it shows the exact number for the last hour). Click the **Details** tab to display the newly handled SMB connections, optimized connections, handed-off connections, dropped connections, and signed connections.

### SMB: Effective WAN Capacity

The SMB Effective WAN Capacity chart displays the effective bandwidth capacity of the WAN link as a result of SMB acceleration, as a multiplier of its base capacity. The capacity data for all traffic and SMB traffic is shown.

**Note**

If the chart has no data, monitoring may be disabled for the application definition that includes this type of traffic.

### SMB: Request Optimization

The SMB Request Optimization chart displays the percentage of SMB command responses that use the following optimizations: read ahead, metadata, write, and other.

## SMB: Response Time Savings

The SMB Response Time Savings chart displays a graph of the round-trip response time saved by the SMB accelerator due to the following optimizations, which are displayed in different colors: read ahead, metadata, Microsoft Office, async write, named pipe, print, and other. The time units (milliseconds, seconds, or minutes) at the left side depend on the range.

## SMB: Versions Detected

The SMB Versions Detected pie chart displays the number of SMB messages detected for each SMB version:

- SMB v1.0 optimized, SMB v1.0 unoptimized, SMB v1.0 signed.
- SMB v2.0 optimized, SMB v2.0 unoptimized, SMBv 2.0 signed optimized and SMB v2.0 signed unoptimized.
- SMB v2.1 optimized, SMB v2.1 unoptimized, SMB v2.1 signed optimized, SMB v2.1 signed unoptimized.
- SMB v3.0 optimized, and SMB v3.0 unoptimized, SMB v3.0 signed, SMBv3.0 Encryption L4 optimized, SMBv3.0 Encryption L7 optimized, SMBv3.0 Encryption unoptimized
- SMBv3.02 optimized, SMB v3.02 unoptimized and SMB v3.02 signed, SMBv3.02 Encryption L4 optimized, SMBv3.02 Encryption L7 optimized, SMBv3.02 Encryption unoptimized

## Independent Computing Architecture (ICA) Acceleration Charts

This section describes these charts:

- [ICA: Client Versions](#)
- [ICA: Connection Details](#)
- [ICA: Effective WAN Capacity](#)
- [ICA: Unaccelerated Reasons](#)

### ICA: Client Versions

The Independent Computing Architecture (ICA) Client Versions pie chart displays the number of ICA messages detected for each ICA version: online plugin 11.0, online plugin 11.2, online plugin 12.0, online plugin 12.1, Citrix Receiver 13.0, and other.

### ICA: Connection Details

The ICA Connection Details chart displays the ICA session connection statistics, showing the average number of active ICA connections per device (at the device level, it shows the exact number for the last hour). Click the **Details** tab to display the newly handled ICA connections, optimized connections, handed-off connections, and dropped connections. Click the **ICA vs ICA over SSL** tab to display the the number of newly handled ICA connections and the number of newly handled ICA over SSL connections.

### ICA: Effective WAN Capacity

The ICA Effective WAN Capacity chart displays the effective bandwidth capacity of the WAN link as a result of ICA acceleration, as a multiplier of its base capacity. The capacity data for all traffic and ICA traffic is shown.



**Note**

If the chart has no data, monitoring may be disabled for the application definition that includes this type of traffic. Verify that monitoring is enabled for the Citrix application.

### ICA: Unaccelerated Reasons

The ICA Unaccelerated Reasons chart displays the reasons that ICA traffic is bypassed: unrecognized protocol, unsupported client version, CGP session ID unknown, client on denied list, no resource, and other. Click the **Dropped** tab to display the reasons because of which ICA traffic is dropped: unsupported client version, I/O error, no resource, AO parsing error, maximum sessions reached, and other.

## Akamai Connected Cache Charts

The WAAS Central Manager provides the following types of monitoring reports for Akamai Connected Cache:

- [Response Time Savings](#)
- [Throughput Summary](#)
- [HTTP: Bandwidth Savings](#)
- [Top Sites](#)
- [Cache Statistics \(Hits\)](#)

To access the following types of charts, choose **Monitor > Caching > Akamai Connect**.

**Note**

Except for the Top Sites chart, you can view monitoring information at the device, network, location, or AppNav cluster levels.

### Response Time Savings

As shown in [Figure 15-9](#), the Response Time Savings chart displays the aggregated amount of time saved due to Akamai Connect caching, showing the response time saved as a percentage, and total response time saved, for cache hit transactions, in minutes.

Figure 15-9 Example of Response Time Savings Chart

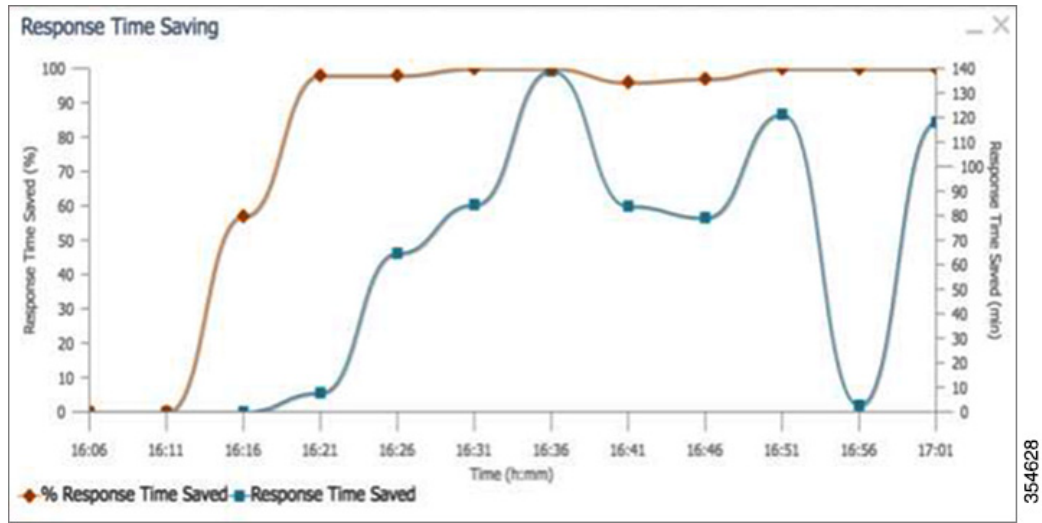

The WAAS CM performs the following percentage calculations:

- Total response time saved
- Total adjusted download time
- Total response time without cache (total response time saved plus total adjusted download time)



#### Note

Output from the **show statistics accelerator http** CLI command also displays information on response time, including the fields Total Time Saved and Percentage of Connection Time Saved. For more information on CLI commands, see the [Cisco Wide Area Application Services Command Reference Guide](#).

## Throughput Summary

The Throughput Summary chart displays information on web-optimized and original throughput. Depending in the tab you click for this chart, LAN-to-WAN (outbound) or WAN-to-LAN (inbound), throughput is displayed. The WAN-to-LAN report is the default report.

If you hover your mouse over a bar, the total optimized or average throughput, in KBps, for a given time range is displayed.

Figure 15-10 Example of Throughput Summary Chart

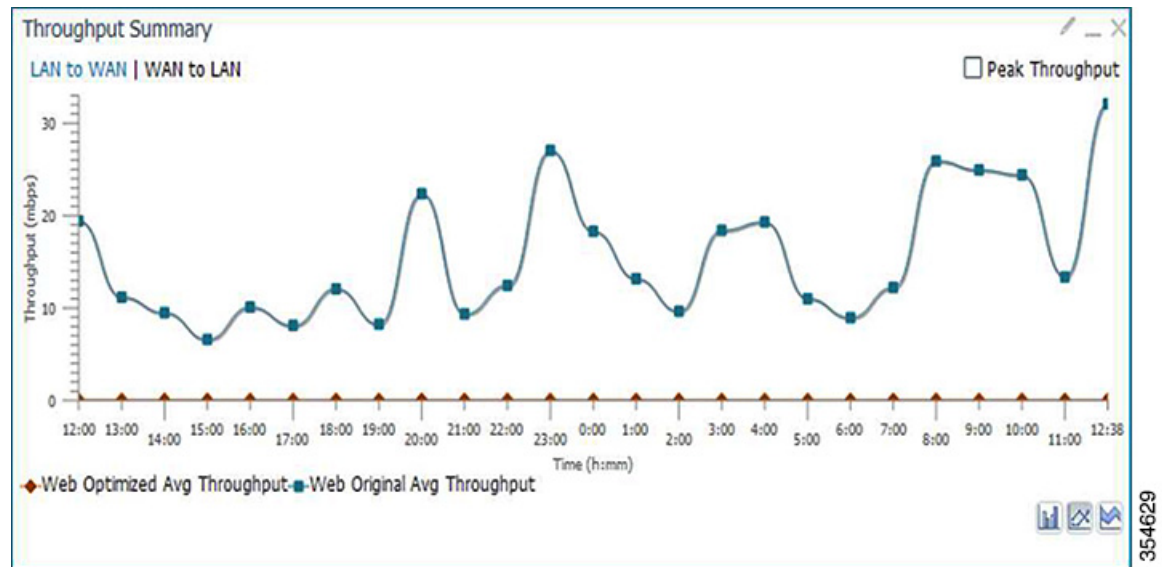

## HTTP: Bandwidth Savings

The HTTP: Bandwidth Savings chart displays how much traffic, by percentage, is actually served by the Cache Engine (CE) that did not have to be fetched from the source.

When this information is combined with overall incoming traffic into the router from the WAN, it indicates how effective the cache is in boosting the WAN performance in terms of request-response latency. The combination of the incoming (WAN) traffic flow to the router, plus the WAN data offload incoming traffic provides a truer measure of the traffic flow the router's clients (in aggregate) experience.

As shown in [Figure 15-11](#):

- The bar graph is the absolute byte count for data served out of cache for the specified interval
- The line graph represents the percentage of total bytes requested that were served out of cache for the specified interval.

**Figure 15-11** Example of HTTP Bandwidth Savings Chart

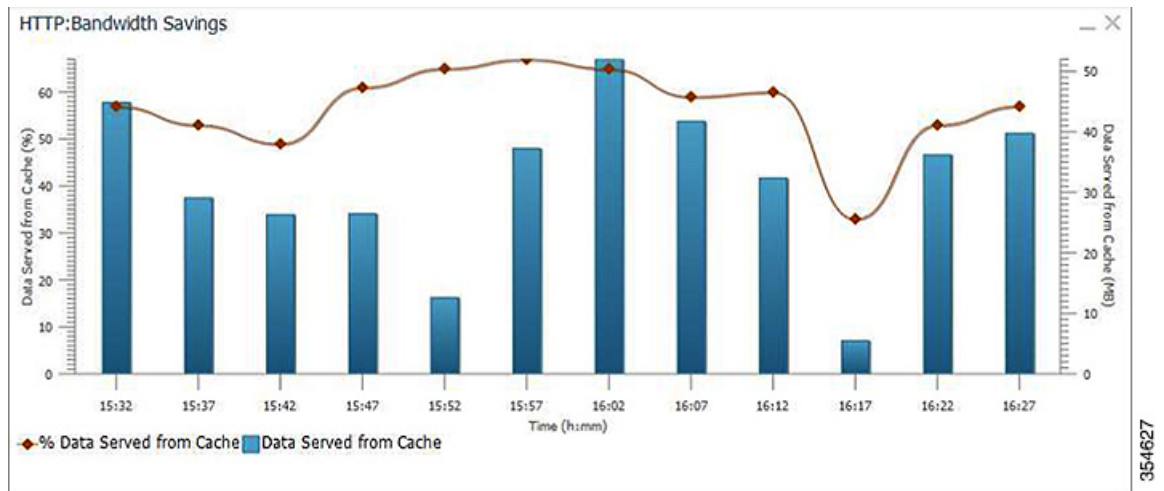

## Top Sites

The Top Sites chart displays the top sites being served by the Cache Engine (CE) in terms of hostname and traffic, in bar chart format. The Top Sites chart displays the following types of information:

- WAN Offload (Default report)—The top URLs by number of bytes served out of the cache, and as a result did not come over the WAN.
- Response Time Saving—The response time saved due to Akamai Connect caching. The time unit, (milliseconds, seconds, or minutes) at the bottom of the chart depend on the time range specified for the chart.
- Hit Count—The top URLs by number of cache hits.
- WAN Response—The top URLs by number of bytes served over the WAN.

**Figure 15-12** Top Sites Chart Showing Response Time Saving by Site

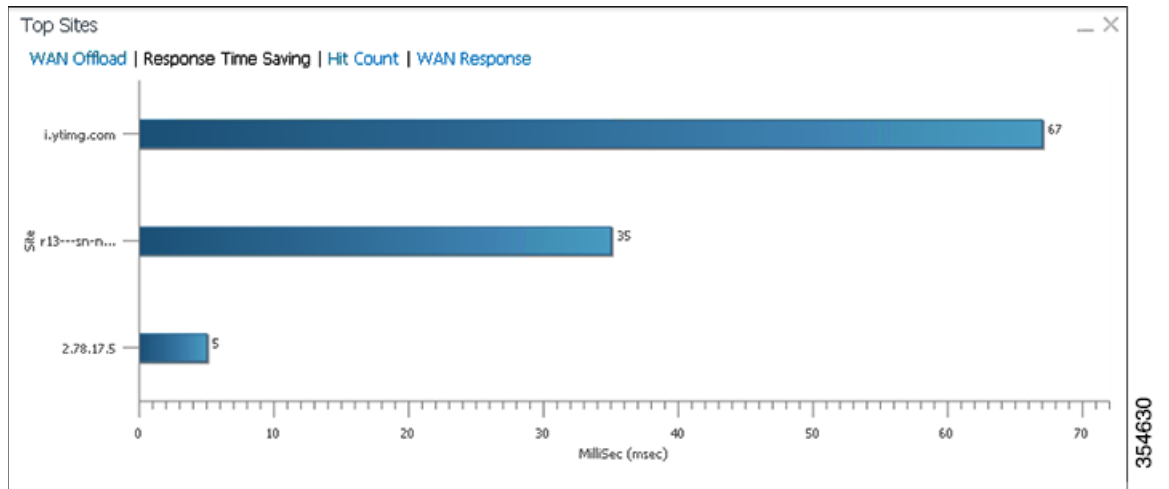

**Note**

Information in the Top Sites chart corresponds to the output for the **show statistics accelerator http object-cache EXEC** command. Top ten sites information is shown as top hosts information, in the Object cache top hosts ordered by: hit count, output section for 0 to 10 hosts. For more information on CLI commands, see the [Cisco Wide Area Application Services Command Reference Guide](#).

## Cache Statistics (Hits)

The Cache Statistics (Hits) chart displays information on cache hits or on data served from the cache, in bar chart format. For each type of Cache Statistics chart, you can specify a time frame of Last Hour, Last Day, Last Week, Last Month, or set a Custom one.

- The Cache Statistics Hits chart shows the percentage and the number of cache hits (in millions) over a specified time frame.

If you hover your mouse over a data point, the total percentage of cache hits for that data point is displayed.

If you hover your mouse over a bar, the number of hits, in millions, is displayed.

- The Cache Statistics Data Served from Cache chart shows the percentage and the amount of data served from cache (in MB) over a specified time frame.

If you hover your mouse over a data point, the total percentage of cache hits for that data point is displayed.

If you hover your mouse over a bar, the total amount, in MB, of data served from the cache, is displayed.

**Figure 15-13** Example of Cache Statistics Hits Chart Showing a Detailed View of a Data Point

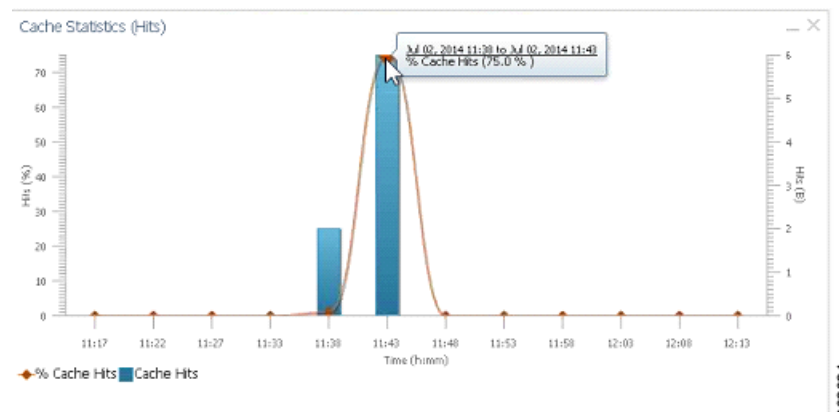

## Connection Trend Charts

This section describes these charts:

- [Optimized Connections Over Time](#)

- [Optimized vs Pass-Through Connections](#)

## Optimized Connections Over Time

The Optimized Connections Over Time chart displays the number of optimized connections over the selected time period. You can show the number of MAPI-reserved connections by checking the **MAPI Reserved Connections** check box. You can view the peak optimized connection values for all the data points in the chart by checking the **Peak Connections** check box. If you have opted to view the peak connections, the chart shows a combination of Optimized Connections as stacked legends and Peak Connections as overlaid lines for selected application/classifiers. In WAAS-XE devices, the Optimized Connections Over Time chart has only the Peak Connections option. You can customize the chart by choosing specific applications to be included. The default is all traffic.

The peak connection value is available for the following:

- **LAST HOUR**—The maximum value (optimized, pass-through connections counters) among the 12 data samples available for the last hour.
- **LAST DAY**—The maximum value (optimized, pass-through connection counters) among the 12 data samples for each hour. For example, if the optimized connection counter values are 10, 20, 30, 40, 50, 60, 70, 80, 90, 100, 110, and 120 for an hour, the peak optimized connection value would be 120.

This chart is available only when a specific WAAS device is selected and can be added only to the Connection Trend report.

## Optimized vs Pass-Through Connections

The Optimized vs Pass-Through Connections chart displays the total number of optimized and pass-through connections on a device or on all devices in a location. You can show the device connection limit, which is the maximum number of connections a device can support, by checking the **Device Connection Limit** check box. This option is available only at the device level. At the Location level, by default, the chart displays only the top five devices series based on the maximum connection limit usage. You can select the devices of your choice from the chart Settings page. The chart in the PDF report displays a maximum of 10 series.

You can view the peak pass-through connection values for all the data points in the chart by checking the **Peak Connections** check box.



### Note

This chart is available only when a specific WAAS device or location is selected, and can be added only to the Connection Trend report.

### Formula:

Pass-Through Connections for a Device = Total Pass-Through Connections for all applications

Optimized Connections for a Device = Total Optimized Connections for all applications

Device Connections limit usage % =  $100 * \text{Average Optimized connections} / \text{Device connection Limit}$   
where,

Average Optimized connections =  $\text{Sum of Optimized Connections} / \text{No. of samples}$

## AppNav Charts

This section describes these charts:

- [Total AppNav Traffic](#)
- [AppNav Policies](#)
- [Top 10 AppNav Policies](#)
- [Top 10 WAAS Node Group Distribution](#)
- [WAAS Node Group Distribution](#)
- [Pass-Through Reasons](#)
- [Top 10 Pass-Through Reasons](#)

### Total AppNav Traffic

The Total AppNav Traffic chart displays the total amount of distributed and pass-through traffic processed by the AppNav Cluster or ANC device. The units at the left side depend upon the range.

### AppNav Policies

The AppNav Policies chart displays a graph of the amount of intercepted, distributed, or pass-through traffic processed by the AppNav Cluster (ANC) or ANC device for each policy rule, depending on which tab you select. The units at the left side depend upon the range.

From the Show Details For drop-down list, select a policy rule for viewing.

### Top 10 AppNav Policies

The Top 10 AppNav Policies pie chart displays the amount of intercepted, distributed, or pass-through traffic processed by the AppNav Cluster or ANC device for the top nine policy rules with the most traffic, depending on which tab you select. Traffic for all other policy rules is grouped together into a tenth category named Other Traffic (shown only if it totals at least 0.1 percent of all traffic).

From the Show Details For drop-down list, select a policy rule for viewing.

### Top 10 WAAS Node Group Distribution

The Top 10 WAAS Node Group (WNG) Distribution pie chart displays the top nine WNGs to which traffic is distributed. Traffic for all other WNGs is grouped together into a tenth category named Other Traffic (shown only if it totals at least 0.1 percent of all traffic).

From the Show Details For drop-down list, select a WNG whose individual Cisco WAAS node details you want to view.

### WAAS Node Group Distribution

The WAAS Node Group Distribution chart displays a graph of the amount of traffic distributed to each WNG. The units at the left side depend upon the range.

From the Show Details For drop-down list, select a WNG whose individual Cisco WAAS node details you want to view.

## Pass-Through Reasons

The Pass-Through Reasons chart displays a graph of the amount of pass-through traffic for each of the pass-through reasons. The units at the left side depend upon the range.

From the Show Details For drop-down list, select a reason whose details you want to view.

## Top 10 Pass-Through Reasons

The Top 10 Pass-Through Reasons pie chart displays the top nine reasons because of which traffic is passed through. Traffic for all other reasons is grouped together into a tenth category named Other Traffic (shown only if it totals at least 0.1 percent of all traffic).

From the Show Details For drop-down list, select a reason whose details you want to view.

## Platform Charts

This section describes these charts:

- [CPU Utilization](#)
- [Disk Utilization](#)

### CPU Utilization

The CPU Utilization chart displays the percentage of CPU utilization for a device. This chart is available only when a specific WAAS device is selected. This chart can be added only to the Monitor > Reports > Reports Central > Resource Utilization report page.

### Disk Utilization

The Disk Utilization chart displays the percentage of disk utilization for a device. This chart is available only when a specific WAAS device is selected. This chart can be added only to the Monitor > Reports > Reports Central > Resource Utilization report page.

## WAAS Table Descriptions

This section describes tables that provide information on system, device, traffic and acceleration. For information on charts that you can choose to include in a dashboard or report, see [WAAS Chart Descriptions](#).

The following statistics details tables are available:

- [Traffic Summary Table](#)
- [Network Application Traffic Details Table](#)
- [HTTP Acceleration Statistics Table](#)
- [HTTPS Acceleration Statistics Table](#)
- [ICA Acceleration Statistics Table](#)
- [MAPI Acceleration Statistics Table](#)



- [NFS Acceleration Statistics Table](#)
- [SMB Acceleration Statistics Table](#)
- [SSL Acceleration Statistics Table](#)

You can sort the tables by clicking any column heading to sort the data in that column. A small triangle appears in the heading to indicate that a column is sorted. Click the triangle to reverse the sort order in the column.

For some values, different formulas are used at the system and device levels, and these formulas are noted in the table descriptions. The terms used in the tables are:

- Original Inbound—Traffic that is entering the WAAS device from the LAN (clients), and needs to be optimized before being sent out on the WAN to a peer WAAS device.
- Original Outbound—Traffic that is exiting the WAAS device to the LAN (clients) after being received on the WAN from a peer WAAS device.
- Optimized Inbound—Traffic that is entering the WAAS device from the WAN, and needs to be processed (deoptimized) before being sent out on the LAN to clients.
- Optimized Outbound—Traffic that is exiting the WAAS device to the WAN and a peer WAAS device after being optimized.
- Pass-Through—Traffic that is being passed through the WAAS device and is not optimized.

To get the statistics at the system, location, and device group levels, the Original Inbound, Original Outbound, Optimized Inbound, Optimized Outbound, Pass-through Client, and Pass-through Server bytes of all devices are added together. The Reduction % and Effective Capacity values are calculated using added values of all devices.

## Traffic Summary Table

This table is called the Network Traffic Summary, Device Traffic Summary, or Location Traffic Summary, depending on the context, and it displays a summary of traffic.

At the system and location levels, each row in the table displays the total traffic information for each device that is registered to the corresponding Central Manager or is in a particular location. At the device level, each row in the table displays the total traffic information for each application defined on the device. The data is described in [Table 15-4](#).

**Table 15-4**      **Traffic Summary Table**

| Table Column                              | Description and Formulas Used to Calculate Value                                                                                                                                                                                |
|-------------------------------------------|---------------------------------------------------------------------------------------------------------------------------------------------------------------------------------------------------------------------------------|
| Device                                    | Displays the device name. (Appears only at the system and location levels.)                                                                                                                                                     |
| Application                               | Displays the application name. (Appears only at the device level.)                                                                                                                                                              |
| Original Traffic (Excludes Pass-Through)  | Reports the amount of original traffic, excluding pass-through traffic.<br>System: $(\text{Original Outbound} + \text{Original Inbound}) / 2$<br>Device / Device Group: $\text{Original Inbound} + \text{Original Outbound}$    |
| Optimized Traffic (Excludes Pass-Through) | Reports the amount of optimized traffic, excluding pass-through traffic.<br>System: $(\text{Optimized Inbound} + \text{Optimized Outbound}) / 2$<br>Device/Device Group: $\text{Optimized Outbound} + \text{Optimized Inbound}$ |

Table 15-4 Traffic Summary Table

| Table Column         | Description and Formulas Used to Calculate Value                                                                                                                                                                                                                                                                                                                                                                                                                                                                                                                                                                                                                                                                                                                         |
|----------------------|--------------------------------------------------------------------------------------------------------------------------------------------------------------------------------------------------------------------------------------------------------------------------------------------------------------------------------------------------------------------------------------------------------------------------------------------------------------------------------------------------------------------------------------------------------------------------------------------------------------------------------------------------------------------------------------------------------------------------------------------------------------------------|
| Pass-Through Traffic | <p>Reports the amount of pass-through traffic. (This value is not applicable for WAAS Express devices.)</p> <p>System: (Pass-through Client + Pass-through Server) / 2</p> <p>Device/Device Group: Pass-through Client + Pass-through Server</p> <p>An asterisk (*) in the column heading indicates that a device whose data is included in this table is configured as a serial peer with another device and optimization is disabled between those two peer devices. The amount of pass-through traffic shown may be more than what is expected because the device passes through traffic coming from its peer. (For more information, see <a href="#">Information About Clustering Inline WAEs</a> in Chapter 5, “Configuring Traffic Interception.”)<sup>1</sup></p> |
| Reduction (%)        | <p>Reports the percentage of bytes saved, considering only optimized traffic.</p> <p>(Original Excl Pass-through – (Optimized)) * 100 / (Original Excl Pass-through)</p>                                                                                                                                                                                                                                                                                                                                                                                                                                                                                                                                                                                                 |
| Effective Capacity   | <p>Reports the effective bandwidth capacity of the WAN link as a result of optimization, as a multiplier of its base capacity, considering only optimized traffic.</p> <p><math>1 / (1 - \% \text{ Reduction Excl Pass-through})</math></p>                                                                                                                                                                                                                                                                                                                                                                                                                                                                                                                              |

- The number in the Pass-Through Traffic column represents the amount of traffic that is passed through that particular WAE (or, in the case of a location report, all the devices in the location). If the device is part of a serial inline cluster (that is, configured as a nonoptimizing peer with another device), the traffic that is shown as pass-through on one device may have been optimized by another device in the serial cluster. It is useful to know the amount of traffic that is not optimized by either of the devices in the cluster (in other words, passed through the entire cluster).

When the device closer to the LAN is not overloaded, the pass through numbers on that device accurately represent the overall pass-through traffic. But, if that device goes into overload, the second device in the cluster starts optimizing traffic that was passed through by the first one, which needs to be accounted for. In such a scenario, the overall pass-through numbers for the cluster can be obtained as follows. Note that this calculation has to be done even if the first device went into overload in the past and came out of it.

Consider that W1 and W2 are part of a serial cluster, and W1 is toward the LAN (closer to the client if the cluster is in the branch, or closer to the server if the cluster is in the data center) and W2 is toward the WAN. The amount of traffic that is passed through the cluster without optimization by either W1 or W2 can be obtained by the following formula: (W1 pass-through traffic) – (W2 original traffic)

## Network Application Traffic Details Table

The Network Application Traffic Details table is available at the system level and displays the total traffic information for each application. The data is the same as described in [Table 15-4](#) (except there is no Device column in this table).

## HTTP Acceleration Statistics Table

The HTTP Acceleration Statistics table is available at the system and device levels and displays HTTP acceleration details. The data is described in [Table 15-5](#).

**Table 15-5 HTTP Acceleration Statistics Table**

| Table Column                                      | Description and Formulas Used to Calculate Value                                                                                                                                                                                |
|---------------------------------------------------|---------------------------------------------------------------------------------------------------------------------------------------------------------------------------------------------------------------------------------|
| Device                                            | Displays the device name. (Appears only at the system level.)                                                                                                                                                                   |
| Start Time and End Time                           | Displays the start time and end time for the time period. (Appears only at the device level.)                                                                                                                                   |
| New Connections Handled                           | Reports the number of HTTP connections handled for the time period.                                                                                                                                                             |
| Average Active Connections/<br>Active Connections | Reports the average active number of connections currently being handled by the HTTP accelerator at the system level. At other levels, reports the number of active connections.                                                |
| New Bypassed Connections                          | Reports the number of connections initially received by the HTTP accelerator and then pushed down to the generic accelerator.                                                                                                   |
| Total Time Saved                                  | Reports the amount of time saved due to HTTP optimization.                                                                                                                                                                      |
| Total Round-Trip Time                             | Reports the total round-trip time for all connections plus the time for remotely served metadata cache misses.                                                                                                                  |
| % Time Saved                                      | Reports the percentage of connection time saved for all aggregated samples.<br><br>Total Time Saved / (Total Time Saved + Total Round Trip Time For All Connections + Total time for all remotely served metadata cache misses) |

## HTTPS Acceleration Statistics Table

The HTTPS Acceleration Statistics table is available at the system and device levels and displays HTTPS acceleration details. The data is described in [Table 15-6](#).

**Table 15-6 HTTPS Acceleration Statistics Table**

| Table Column                                      | Description and Formulas Used to Calculate Value                                                                                                                                                                |
|---------------------------------------------------|-----------------------------------------------------------------------------------------------------------------------------------------------------------------------------------------------------------------|
| Device                                            | Displays the device name. (Appears only at the system level.)                                                                                                                                                   |
| Start Time and End Time                           | Displays the start time and end time for the time period. (Appears only at the device level.)                                                                                                                   |
| New Connections Handled                           | Reports the number of HTTPS connections handled for the time period.                                                                                                                                            |
| Average Active Connections/<br>Active Connections | Reports the average number of connections currently being handled by the HTTP/SSL accelerator at the system level. At other levels, reports the number of active connections.                                   |
| Total Time Saved                                  | Reports the amount of time saved due to HTTPS optimization.                                                                                                                                                     |
| Total Round-Trip Time                             | Reports the total round-trip time for all connections plus the time for remotely served metadata cache misses.                                                                                                  |
| % Time Saved                                      | Reports the percentage of connection time saved for all aggregated samples.<br><br>Total Time Saved by cache hits / (Total Time Saved by cache hits + Total time for all remotely served metadata cache misses) |

## ICA Acceleration Statistics Table

The ICA Acceleration Statistics table is available at the system and device levels and displays ICA acceleration details. The data is described in [Table 15-7](#).

**Table 15-7** ICA Acceleration Statistics Table

| Table Column                                      | Description and Formulas Used to Calculate Value                                                                                                                         |
|---------------------------------------------------|--------------------------------------------------------------------------------------------------------------------------------------------------------------------------|
| Device                                            | Displays the device name. (Appears only at the system level. WAAS Express devices are not included.)                                                                     |
| Start Time and End Time                           | Displays the start time and end time for the time period. (Appears only at the device level.)                                                                            |
| New Connections Handled                           | Reports the number of ICA connections handled for the time period.                                                                                                       |
| Average Active Connections/<br>Active Connections | Reports the average number of connections currently being handled by the ICA accelerator at the system level. At other levels, reports the number of active connections. |
| Dropped Connections                               | Reports the number of connections dropped by the ICA accelerator.                                                                                                        |
| Bypassed Connections                              | Reports the number of connections initially received by the ICA accelerator and then pushed down to the generic accelerator.                                             |

## MAPI Acceleration Statistics Table

The MAPI Acceleration Statistics table is available at the system and device levels and displays MAPI acceleration details. The data is described in [Table 15-8](#).

**Table 15-8** MAPI Acceleration Statistics Table

| Table Column                                      | Description and Formulas Used to Calculate Value                                                                                                                          |
|---------------------------------------------------|---------------------------------------------------------------------------------------------------------------------------------------------------------------------------|
| Device                                            | Displays the device name. (Appears only at the system level. WAAS Express devices are not included.)                                                                      |
| Start Time and End Time                           | Displays the start time and end time for the time period. (Appears only at the device level.)                                                                             |
| New Connections Handled                           | Reports the number of MAPI connections handled for the time period.                                                                                                       |
| Average Active Connections/<br>Active Connections | Reports the average number of connections currently being handled by the MAPI accelerator at the system level. At other levels, reports the number of active connections. |
| New Bypassed Connections                          | Reports the number of connections initially received by the MAPI accelerator and then pushed down to the generic accelerator.                                             |
| New Local Request Count                           | Reports the number of client requests handled locally by the WAE.                                                                                                         |
| Avg. Local Response Time                          | Reports the average time used for local responses, in microseconds.                                                                                                       |
| New Remote Request Count                          | Reports the number of client requests handled remotely over the WAN.                                                                                                      |
| Avg. Remote Response Time                         | Reports the average time used for remote responses, in microseconds.                                                                                                      |
| Average Time Saved                                | Reports the average connection time saved for all aggregated samples, in microseconds.                                                                                    |

## NFS Acceleration Statistics Table

The NFS Acceleration Statistics table is available at the system and device levels and displays NFS acceleration details. The data is described in [Table 15-9](#).

**Table 15-9 NFS Acceleration Statistics Table**

| Table Column                                      | Description and Formulas Used to Calculate Value                                                                                                                                                                                                                                                                                                                                                                                                |
|---------------------------------------------------|-------------------------------------------------------------------------------------------------------------------------------------------------------------------------------------------------------------------------------------------------------------------------------------------------------------------------------------------------------------------------------------------------------------------------------------------------|
| Device                                            | Displays the device name. (Appears only at the system level. WAAS Express devices are not included.)                                                                                                                                                                                                                                                                                                                                            |
| Start Time and End Time                           | Displays the start time and end time for the time period. (Appears only at the device level.)                                                                                                                                                                                                                                                                                                                                                   |
| New Connections Handled                           | Reports the number of NFS connections handled for the time period.                                                                                                                                                                                                                                                                                                                                                                              |
| Average Active Connections/<br>Active Connections | Reports the average number of connections currently being handled by the NFS accelerator at the system level. At other levels, reports the number of active connections.                                                                                                                                                                                                                                                                        |
| New Bypassed Connections                          | Reports the number of connections initially received by the NFS accelerator and then pushed down to the generic accelerator.                                                                                                                                                                                                                                                                                                                    |
| New Local Request Count                           | Reports the number of client requests handled locally by the WAE.                                                                                                                                                                                                                                                                                                                                                                               |
| Avg. Local Response Time                          | Reports the average time used for local responses, in milliseconds.                                                                                                                                                                                                                                                                                                                                                                             |
| New Remote Request Count                          | Reports the number of client requests handled remotely over the WAN.                                                                                                                                                                                                                                                                                                                                                                            |
| Avg. Remote Response Time                         | Reports the average time used for remote responses, in milliseconds.                                                                                                                                                                                                                                                                                                                                                                            |
| % Time Saved                                      | Reports the percentage of connection time saved for all aggregated samples.<br>$\frac{(\text{Down} - \text{Up}) * 100}{(\text{Down})}$ If(Down != 0)<br>Here:<br>$\text{Down} = (\text{New local request count} + \text{New remote request count}) * \text{Avg. local response time}$ $\text{Up} = ((\text{New local request count} * \text{Avg. local response time}) + (\text{New remote request count} * \text{Avg. remote response time}))$ |

## SMB Acceleration Statistics Table

The SMB Acceleration Statistics table is available at the system and device levels and displays SMB acceleration details. The data is described in [Table 15-10](#).

**Table 15-10 SMB Acceleration Statistics Table**

| Table Column            | Description and Formulas Used to Calculate Value                                                     |
|-------------------------|------------------------------------------------------------------------------------------------------|
| Device                  | Displays the device name. (Appears only at the system level. WAAS Express devices are not included.) |
| Start Time and End Time | Displays the start time and end time for the time period. (Appears only at the device level.)        |
| New Connections Handled | Reports the number of SMB connections handled for the time period.                                   |

**Table 15-10 SMB Acceleration Statistics Table**

| Table Column                                      | Description and Formulas Used to Calculate Value                                                                                                                                                                |
|---------------------------------------------------|-----------------------------------------------------------------------------------------------------------------------------------------------------------------------------------------------------------------|
| Average Active Connections/<br>Active Connections | Reports the average number of connections currently being handled by the SMB accelerator at the system level. At other levels, reports the number of active connections.                                        |
| Bypassed Connections                              | Reports the number of connections initially received by the SMB accelerator and then pushed down to the generic accelerator.                                                                                    |
| Total Time Saved                                  | Reports the amount of time saved due to SMB optimization.                                                                                                                                                       |
| Total Round-Trip Time                             | Reports the total round-trip time for all connections plus the time for remotely served metadata cache misses.                                                                                                  |
| % Time Saved                                      | Reports the percentage of connection time saved for all aggregated samples.<br><br>Total Time Saved by cache hits / (Total Time Saved by cache hits + Total Time for all remotely served metadata cache misses) |

## SSL Acceleration Statistics Table

The SSL Acceleration Statistics table is available at the system and device levels and displays SSL acceleration details. The data is described in [Table 15-11](#).

**Table 15-11 SSL Acceleration Statistics Table**

| Table Column                                      | Description                                                                                                                                                              |
|---------------------------------------------------|--------------------------------------------------------------------------------------------------------------------------------------------------------------------------|
| Device                                            | Displays the device name. (Appears only at the system level.)                                                                                                            |
| Start Time and End Time                           | Displays the start time and end time for the time period. (Appears only at the device level.)                                                                            |
| New Connections Handled                           | Reports the number of SSL connections handled for the time period.                                                                                                       |
| Average Active Connections/<br>Active Connections | Reports the average number of connections currently being handled by the SSL accelerator at the system level. At other levels, reports the number of active connections. |
| New HTTPS Connections Handled                     | Reports the number of HTTPS connections handled by the SSL accelerator.                                                                                                  |
| Dropped Connections                               | Reports the number of connections dropped by the SSL accelerator.                                                                                                        |
| Bypassed Connections                              | Reports the number of connections initially received by the SSL accelerator and then pushed down to the generic accelerator.                                             |

## Using Predefined Reports to Monitor WAAS

The WAAS Central Manager includes a number of predefined reports that you can use to monitor system operation. These reports are available from the Monitor menu. The reports consist of a combination of specific charts and graphs and a statistical table displayed in the lower part of the WAAS Central Manager window.

You can customize these predefined reports by editing them with the Manage Report function available in the Monitor menu, as described in [Viewing and Editing a Report](#).

This section contains the following topics:

- [Predefined Reports Available by WAAS Level](#)
- [Location-Level Reports](#)
- [TCP Summary Report](#)
- [HTTP Acceleration Report](#)
- [HTTPS Acceleration Report](#)
- [SSL Acceleration Report](#)
- [MAPI Acceleration Report](#)
- [NFS Acceleration Report](#)
- [SMB Acceleration Report](#)
- [ICA Acceleration Report](#)
- [Summary Report](#)
- [Topology Report](#)
- [Connection Trend Report](#)
- [Connections Statistics Report](#)
- [Resource Utilization Report](#)
- [Disks Report](#)
- [AppNav Report](#)
- [Exported Reports](#)

## Predefined Reports Available by WAAS Level

This section contains the following tables:

- [Table 15-12](#), “Predefined Reports Available at System, AppNav Cluster, Location, and Device Level”
- [Table 15-13](#), “Predefined Reports Available at Specified Levels”

[Table 15-12](#) shows the predefined reports available at the WAAS system level, the AppNav Cluster level, the location level, and the device level.

**Table 15-12** *Predefined Reports Available at System, AppNav Cluster, Location, and Device Level*

| Report Type  | Available Reports                                                                      |
|--------------|----------------------------------------------------------------------------------------|
| Optimization | <ul style="list-style-type: none"> <li>• <a href="#">TCP Summary Report</a></li> </ul> |

| Report Type                                                            | Available Reports                                                                                                                                                                                                                                                                                                                                                                                                 |
|------------------------------------------------------------------------|-------------------------------------------------------------------------------------------------------------------------------------------------------------------------------------------------------------------------------------------------------------------------------------------------------------------------------------------------------------------------------------------------------------------|
| Acceleration (not all reports available for WAAS Express device level) | <ul style="list-style-type: none"> <li>• <a href="#">HTTP Acceleration Report</a></li> <li>• <a href="#">HTTPS Acceleration Report</a></li> <li>• <a href="#">SSL Acceleration Report</a></li> <li>• <a href="#">MAPI Acceleration Report</a></li> <li>• <a href="#">NFS Acceleration Report</a></li> <li>• <a href="#">SMB Acceleration Report</a></li> <li>• <a href="#">ICA Acceleration Report</a></li> </ul> |
| Caching and Akamai Connected Cache                                     | <ul style="list-style-type: none"> <li>• <a href="#">Cache Statistics (Hits)</a></li> <li>• <a href="#">Throughput Summary</a></li> <li>• <a href="#">HTTP: Bandwidth Savings</a></li> <li>• <a href="#">Top Sites</a></li> </ul>                                                                                                                                                                                 |

Table 15-13 shows the predefined reports available at specified WAAS levels.

**Table 15-13** Predefined Reports Available at Specified Levels

| WAAS Level                                                          | Report Type                                                                                                            | Available Reports                                                                                                                       |
|---------------------------------------------------------------------|------------------------------------------------------------------------------------------------------------------------|-----------------------------------------------------------------------------------------------------------------------------------------|
| System level                                                        | <ul style="list-style-type: none"> <li>• Network</li> </ul>                                                            | <ul style="list-style-type: none"> <li>• <a href="#">Summary Report</a></li> </ul>                                                      |
| System and Device levels                                            | <ul style="list-style-type: none"> <li>• Network/Peers</li> </ul>                                                      | <ul style="list-style-type: none"> <li>• <a href="#">Topology Report</a></li> </ul>                                                     |
| Device and Location levels                                          | <ul style="list-style-type: none"> <li>• Optimization</li> </ul>                                                       | <ul style="list-style-type: none"> <li>• <a href="#">Connection Trend Report</a></li> </ul>                                             |
| Device level                                                        | <ul style="list-style-type: none"> <li>• Optimization</li> </ul>                                                       | <ul style="list-style-type: none"> <li>• <a href="#">Connections Statistics Report</a></li> </ul>                                       |
|                                                                     | <ul style="list-style-type: none"> <li>• Acceleration</li> </ul>                                                       | <ul style="list-style-type: none"> <li>• <a href="#">SMB Acceleration Report</a></li> </ul>                                             |
|                                                                     | <ul style="list-style-type: none"> <li>• Platform (not available at WAAS Express or AppNav-XE device level)</li> </ul> | <ul style="list-style-type: none"> <li>• <a href="#">Resource Utilization Report</a></li> <li>• <a href="#">Disks Report</a></li> </ul> |
| AppNav Cluster level and Device level for AppNav Controller devices | <ul style="list-style-type: none"> <li>• AppNav</li> </ul>                                                             | <ul style="list-style-type: none"> <li>• <a href="#">AppNav Report</a></li> </ul>                                                       |



**Note**

In a WAAS network where there are 1000 or more WAEs, there may be a delay of up to 90 seconds to redisplay the table when you click a table column to sort a system-level report table. You may experience a similar delay when you click the **Print** icon in the taskbar before you see the report.

## Location-Level Reports

Location-level reports aggregate data from all the WAEs present in a particular location. For more information about locations, see [Working with Device Locations](#) in Chapter 3, “Using Device Groups and Device Locations.”

To view a location-level report, follow these steps:



- 
- Step 1** From the WAAS Central Manager menu, choose **Locations** > *location-name*.
- Step 2** From the WAAS Central Manager menu, choose **Monitor** and choose the report from the Optimization or Acceleration categories.
- 

When scheduling any report, you can also select one or more locations; the report will include data from all the devices within the selected locations. For more information, see [Scheduling a Report](#).

The maximum number of devices supported in a location-level report is 25 by default. This number is configurable up to 250 by the `System.monitoring.maxDevicePerLocation` system property. For more information, see [Modifying the Default System Configuration Properties](#) in Chapter 10, “Configuring Other System Settings.”

## TCP Summary Report

The Transmission Control Protocol (TCP) Summary report displays a summary of all traffic. The following charts and tables are included:

- [Traffic Summary](#)
- [Effective WAN Capacity](#)
- [Traffic Volume and Reduction](#)
- [Compression Summary](#)
- [Traffic Summary Over Time](#)
- [Compression Summary Over Time](#)
- [Throughput Summary, page 15-15](#) (included only at the device and location levels)
- [Traffic Summary Table](#)

## HTTP Acceleration Report

The HTTP Acceleration report displays the HTTP acceleration statistics. The following charts and tables are included:

- [HTTP: Estimated Time Savings](#)
- [HTTP: Effective WAN Capacity](#)
- [HTTP: Connection Details](#)
- [HTTP: Response Time Savings](#)
- [HTTP: Optimization Count](#)
- [HTTP: Optimization Techniques](#)
- [HTTP Acceleration Statistics Table](#)

The WAAS Central Manager provides monitoring information on the following types of caching: Basic, Standard, Advanced, Bypass, and Connected Cache. Except for the Top Sites chart, you can view monitoring information at the device, network, location, or AppNav cluster levels. The following charts are included:

- [Akamai Connected Cache Charts](#)

- [Cache Statistics \(Hits\)](#)
- [Throughput Summary](#)
- [HTTP: Bandwidth Savings](#)
- [Top Sites](#)

## HTTPS Acceleration Report

The HTTPS Acceleration report displays the HTTPS acceleration statistics. The following charts and tables are included:

- [HTTPS: Estimated Time Savings](#)
- [HTTPS: Effective WAN Capacity](#)
- [HTTPS: Connection Details](#)
- [HTTPS: Response Time Savings](#)
- [HTTPS: Optimization Count](#)
- [HTTPS: Optimization Techniques](#)
- [HTTPS Acceleration Statistics Table](#)

## SSL Acceleration Report

The SSL Acceleration report displays the SSL acceleration statistics. The following charts and tables are included:

- [SSL: Connection Details](#)
- [SSL: Effective WAN Capacity](#)
- [SSL: Acceleration Bypass Reason](#)
- [SSL Acceleration Statistics Table](#)

## MAPI Acceleration Report

The MAPI Acceleration report displays the MAPI acceleration statistics. The following charts and tables are included:

- [MAPI: Average Response Time Saved](#)
- [MAPI: Effective WAN Capacity](#)
- [MAPI: Connection Details](#)
- [MAPI: Request Optimization](#)
- [MAPI: Response Time Optimization](#)
- [MAPI: Average Accelerated Client Sessions](#)
- [MAPI: Acceleration Bypass Reason](#)
- [MAPI Acceleration Statistics Table](#)

## NFS Acceleration Report

The NFS Acceleration report displays the NFS acceleration statistics. The following charts and tables are included:

- [NFS: Estimated Time Savings](#)
- [NFS: Effective WAN Capacity](#)
- [NFS: Connection Details](#)
- [NFS: Request Optimization](#)
- [NFS: Response Time Optimization](#)
- [NFS: Versions Detected](#)
- [NFS: Acceleration Bypass Reason](#)
- [NFS Acceleration Statistics Table](#)

## SMB Acceleration Report

The SMB Acceleration report displays the SMB acceleration statistics. The following charts and tables are included:

- [SMB: Average Response Time Saved](#)
- [SMB: Effective WAN Capacity](#)
- [SMB: Connection Details](#)
- [SMB: Request Optimization](#)
- [SMB: Response Time Savings](#)
- [SMB: Client Average Throughput](#)
- [SMB: Versions Detected](#)
- [SMB Acceleration Statistics Table](#)

## ICA Acceleration Report

The ICA Acceleration report displays the ICA acceleration statistics. The following charts and tables are included:

- [ICA: Effective WAN Capacity](#)
- [ICA: Connection Details](#)
- [ICA: Client Versions](#)
- [ICA: Unaccelerated Reasons](#)
- [ICA Acceleration Statistics Table](#)

**Note**

The ICA charts in WAAS Version 5.0 and later are different from those used in Version 4.5. If you are viewing the data from a Version 4.5 WAAS device, the charts appear empty due to the different data that the device is collecting. The ICA data for Version 4.5 WAAS devices is available in the system-level TCP Summary Report. For more information, see [TCP Summary Report](#).

## Summary Report

The Summary Report is a predefined report that can be used to monitor system operation. It is available at the system level. This report displays the following charts and tables by default:

- [Traffic Summary](#)
- [Effective WAN Capacity](#)
- [Traffic Summary Over Time](#)
- [Traffic Volume and Reduction](#)
- [Compression Summary](#)
- [Compression Summary Over Time](#)
- [HTTP: Estimated Time Savings](#)
- [HTTP: Effective WAN Capacity](#)
- [MAPI: Effective WAN Capacity](#)
- [SSL: Effective WAN Capacity](#)
- [MAPI: Average Response Time Saved](#)
- [Network Application Traffic Details Table](#)

The Summary Report can be customized to display the charts that you require. Use the **Customize** taskbar icon to select the charts that you want to be displayed in this report. Only 12 charts can be displayed in the report.

## Topology Report

The Topology report at the system level displays a topology map that shows a graphical representation of all the connections between the WAAS devices.

The topology map uses blue squares to show connections between devices. Use the legend to the right of the grid to associate the device name with the number that appears at the top of the grid. Use the drop-down lists at the top of the window to perform the following tasks:

- Display connections between your various locations instead of between devices.
- Sort the grid by the number of connections instead of by device name.

Click the **View** icon next to the WAE to view a list of peer devices for a specific WAE. The Peer List window appears, which is the same as the device level Topology report.

At the device level, the Topology report lists all the peer devices connected to a specific WAE so that you can see the relationship between devices in your WAAS network. The Peer List window displays information about each peer device involved in optimized connections with this WAE. To go to the system level Topology report, click the **Topology** icon in the taskbar.

If a peer device is not registered with the WAAS Central Manager, the message **Unknown, this peer is not being managed by CM** is displayed for the name and **Unknown** is displayed for the IP address.



### Note

The WAAS Central Manager device does not have any peers because it does not participate with any WAEs to optimize traffic. For this reason, the topology feature is not available on the WAAS Central Manager device.

## Connection Trend Report

The Connection Trend Report displays the connection trends of applications on a device. The following charts are included:

- [Optimized Connections Over Time](#)
- [Optimized vs Pass-Through Connections](#)

## Connections Statistics Report

The Connections Statistics report displays a Connections Statistics table for the device. The table displays all the TCP connections handled by the device and corresponds to the **show statistics connection** EXEC mode command in WAE and the **show waas connection brief** command in WAAS Express.

You can choose to display a subset of connections identified by IP address and port by entering values in the Source/Destination IP Address and Source/Destination Port fields above the table and clicking **Submit**. To see the Connection Start Time for the active connections in appropriate time zones, you can select the time zone from the available values of **CM Local Time**, **Device Local Time** and **UTC** from the Show Connection Start Time drop-down list.

**Note**

In case of a clock or timezone change in the WAE, the exact time for device timezone is reflected after the configuration synchronization cycles.

The Connection Statistics table displays the following information about each connection:

- Source IP address and port.
- Destination IP address and port.
- Peer ID—Hostname of the peer device.
- Applied Policy/Bypass Reason—Displays icons representing the applied optimization policies, including TFO, DRE, LZ, and an application accelerator, respectively. (Hover your mouse over the icon to see its meaning.) If the connection is not optimized, the bypass reason is shown.
- Connection Start Time—Date and time at which the connection was started.
- Open Duration—Number of hours, minutes, and seconds that the connection has been open.
- Total number of original bytes.
- Total number of optimized bytes.
- Percentage of compression.
- Class map name—If no class map exists for the connection, this column contains a dash. To create a class map for this connection, click the radio button at the left of the row and then click the **Create Class-Map** taskbar icon to display the Optimization Class-Map pane. For details on creating a class map and match conditions, see [Chapter 12, “Configuring Application Acceleration”](#).

**Note**

If the WAE is inheriting policies from a device group, the Create Class-Map button is dimmed, to prevent a user from unknowingly overriding device group policies. To create a class map, you must first override the device group policy page and then return to the Connection Statistics report.

The data in the Connections Statistics table is retrieved from the device once when you view the table for the first time.

From the Connections Statistics table, you can perform the following tasks:

- Apply filter settings to display particular connections based on specific criteria, by choosing **Quick Filter** from the Show drop-list in the taskbar.
- Refresh the table by clicking the **Refresh** taskbar icon.
- Export the table to a spreadsheet by clicking the **Export** taskbar icon.
- View connection details by clicking the **Details** icon next to the connection entry.

The Connection Details window contains connection addresses, port information, policy information, and traffic statistics. It also displays graphs that plot real-time traffic statistics and are refreshed every two seconds.



---

**Note** In the Connection Details window, if the value for Percentage Compression is negative, the Percentage Compression and Effective Capacity values do not appear.

---

In some cases, the Central Manager is not able to fetch the Connections Statistics page details at the WAE device level. This happens when the WAE uses internal IP for management purpose with the Central Manager and external IP (NAT) for RPC or registration purpose with the WAAS Central Manager, and if the internal IP not reachable from the WAAS Central Manager.

## Resource Utilization Report

The Resource Utilization report displays the following charts:

- [CPU Utilization](#)
- [Disk Utilization](#)

## Disks Report

The Disks Report displays physical and logical disk information.

The report window displays the following information about each disk:

- Physical disk information, including the disk name, serial number, and disk size.
- Present status. The Present field will show either **Yes** if the disk is present or **Not Applicable** if the disk is administratively shut down.
- Operational status—NORMAL, REBUILD, BAD, UNKNOWN, or Online.
- Administrative status—ENABLED or DISABLED. When the Administrative Status field shows DISABLED, the Present field will show Not Applicable.
- Current and future disk encryption status.
- RAID level. For RAID-5 devices, the Disk Information window includes the RAID device name, RAID status, and RAID device size.
- Error information, if any errors are detected.

From this window, you can save all disk information details to an Excel spreadsheet by clicking the **Export Table** icon in the taskbar.

## AppNav Report

The AppNav report displays AppNav flow distribution information. This report is available at the AppNav Cluster level, where it shows statistics for the whole AppNav Cluster, and at the device level for AppNav Controllers (ANCs), where it shows statistics for a single ANC.

The following charts and tables are included:

- [Total AppNav Traffic](#)
- [AppNav Policies](#)
- [Top 10 AppNav Policies](#)
- [Top 10 WAAS Node Group Distribution](#)
- [WAAS Node Group Distribution](#)
- [Pass-Through Reasons](#)
- [Top 10 Pass-Through Reasons](#)

At the AppNav Cluster level, the following additional controls appear in the taskbar:

- The Scope drop-down list allows you to choose to display data for the whole cluster or for an individual ANC.
- The AppNav Policy Rule drop-down list allows you to choose the AppNav policy for which data is displayed (shown for WAAS appliance AppNav clusters only.)
- The Context drop-down list allows you to choose the AppNav context (or all contexts) for which data is displayed (shown for AppNav-XE clusters only.)



### Note

At the AppNav Cluster level, the charts may not show data if the configuration on all ANCs in the cluster does not match. To resolve this situation, choose **AppNav Clusters > cluster-name** from the Central Manager menu and click the taskbar icon named **Force Settings on all Devices in a Group**. After about 15 minutes, the AppNav charts will display data.

## Exported Reports

Using the spreadsheet icon in the Central Manager taskbar, you can export chart values to a CSV file.

[Table 15-14](#) provides descriptions of report column headings for exported reports. Because there are many report column headings, the table is divided into categories by types of traffic, in alphabetical order. For these heading descriptions, a time specification (for example, milliseconds) is not noted, as the time specification may change depending on the time period specified for the report (for example, hour or week).

week).

- [Akamai Connected Cache](#)
- [Akamai Connected Cache Top Sites](#)
- [Application, Time, and Time Saved](#)
- [Cache Control Header and Cache](#)

- Connections: Active, Dropped, Incomplete, Pending
- Connections: Handled, Optimized, Prepositioned
- Connections: Idle, Reused, Timeout
- Connections: Handoffs, Pass Through, Piped Through
- DRE and LZ Compression
- Locally Served and Remotely Served
- Round Trip Time (RTT)
- Session
- Sharepoint
- Throughput
- Transactions

**Table 15-14** Exported Report Column Headings

| Report Column Heading                   | Description                                                                                                                                                                                                                                                                                                                                                                                                                                                                                                                                                                                                                                                                                                                                                                                                                                                                                                                                                                                                                                                                                                |
|-----------------------------------------|------------------------------------------------------------------------------------------------------------------------------------------------------------------------------------------------------------------------------------------------------------------------------------------------------------------------------------------------------------------------------------------------------------------------------------------------------------------------------------------------------------------------------------------------------------------------------------------------------------------------------------------------------------------------------------------------------------------------------------------------------------------------------------------------------------------------------------------------------------------------------------------------------------------------------------------------------------------------------------------------------------------------------------------------------------------------------------------------------------|
| <b>Akamai Connected Cache</b>           |                                                                                                                                                                                                                                                                                                                                                                                                                                                                                                                                                                                                                                                                                                                                                                                                                                                                                                                                                                                                                                                                                                            |
| <b>ce_cachetype_hit_count</b>           | <p>For the Akamai Connect Cache Engine, exported reports show the following types of information:</p> <p>Hit Count—The top URLs by number of cache hits.</p> <p>Hit Miss—The number of object cache responses not cached.</p> <p>Hit Response—The number of object cache response bytes for cache-hit transactions.</p> <p>WAN Response—The top URLs by number of bytes served over the WAN.</p> <p>Depending on which cache types are enabled and what traffic is seen, the output may show statistics for any or all of the following cache types:</p> <ul style="list-style-type: none"> <li>• Connected Cache (example: <b>ce_connect_hit_count</b>)</li> <li>• Bypass (example: <b>ce_bypass_hit_miss</b>)</li> <li>• Standard, (example: <b>ce_standard_hit_response</b>)</li> <li>• Basic (example: <b>ce_basic_wan_response</b>)</li> <li>• Advanced (example: <b>ce_advanced_hit_count</b>)</li> <li>• OTT-youtube (example: <b>ce_ott_hit_miss</b>)</li> <li>• OTT-generic (example: <b>ce_ott-generic_hit_response</b>)</li> <li>• unknown (example: <b>ce_unknown_wan_response</b>)</li> </ul> |
| <b>ce_cachetype_hit_miss</b>            |                                                                                                                                                                                                                                                                                                                                                                                                                                                                                                                                                                                                                                                                                                                                                                                                                                                                                                                                                                                                                                                                                                            |
| <b>ce_cachetype_hit_response</b>        |                                                                                                                                                                                                                                                                                                                                                                                                                                                                                                                                                                                                                                                                                                                                                                                                                                                                                                                                                                                                                                                                                                            |
| <b>ce_cachetype_wan_response</b>        |                                                                                                                                                                                                                                                                                                                                                                                                                                                                                                                                                                                                                                                                                                                                                                                                                                                                                                                                                                                                                                                                                                            |
| <b>total_aggregate_time_saved</b>       | Aggregated amount of time saved due to Akamai Connect caching.                                                                                                                                                                                                                                                                                                                                                                                                                                                                                                                                                                                                                                                                                                                                                                                                                                                                                                                                                                                                                                             |
| <b>Akamai Connected Cache Top Sites</b> |                                                                                                                                                                                                                                                                                                                                                                                                                                                                                                                                                                                                                                                                                                                                                                                                                                                                                                                                                                                                                                                                                                            |
| <b>Hit Count</b>                        | The top URLs by number of cache hits.                                                                                                                                                                                                                                                                                                                                                                                                                                                                                                                                                                                                                                                                                                                                                                                                                                                                                                                                                                                                                                                                      |
| <b>Response Time Savings</b>            | The response time saved due to Akamai Connect caching.                                                                                                                                                                                                                                                                                                                                                                                                                                                                                                                                                                                                                                                                                                                                                                                                                                                                                                                                                                                                                                                     |



| Report Column Heading                                                            | Description                                                                                                                                                                                               |
|----------------------------------------------------------------------------------|-----------------------------------------------------------------------------------------------------------------------------------------------------------------------------------------------------------|
| <b>Site</b>                                                                      | The names of the top sites being served by the Akamai Cache Engine, in terms of hostname and traffic.                                                                                                     |
| <b>Timestamp</b>                                                                 | The date and time of the information recorded, for each row of the report.                                                                                                                                |
| <b>WAN Offload</b>                                                               | The top URLs by number of bytes served out of the cache, and as a result did not come over the WAN.                                                                                                       |
| <b>WAN Response</b>                                                              | The top URLs by number of bytes served over the WAN.                                                                                                                                                      |
| <b>Application, Time, and Time Saved</b>                                         |                                                                                                                                                                                                           |
| <b>timestamp</b>                                                                 | The date and time of the information recorded, for each row of the report.                                                                                                                                |
| <b>Application Name</b>                                                          | Type of application for the reported data, such as enterprise, backup, replication, file system, email and messaging, file system, storage, web, file transfer, streaming, printing, or remote desktop.   |
| <b>time_saved</b>                                                                | Total response time saved, for cache hit transactions. The time is incremented on the client side WAE by one RTT whenever an idle fast connection is reused instead of establishing a new WAN connection. |
| <b>total_adjusted_download_time</b>                                              | The total adjusted download time.                                                                                                                                                                         |
| <b>total_aggregate_time_saved</b>                                                | Aggregated amount of time saved due to Akamai Connect caching.                                                                                                                                            |
| <b>Cache Control Header and Cache</b>                                            |                                                                                                                                                                                                           |
| <b>httpao_requests_cache_control_denies_cached_resp</b>                          | Number of requests not to be cached, as specified by a Cache-Control header.                                                                                                                              |
| <b>httpao_responses_cache_control_prevents_caching</b>                           | Number of OK (200), Redirected (301), Not Modified (304), and Unauthorized (401) responses not to be cached, as specified by a Cache-Control header.                                                      |
| <b>httpao_long_url</b>                                                           | Number of responses not cached because the URL is longer than 255 characters. The URL length includes the length of the destination IP address.                                                           |
| <b>httpao_total_time_cache_miss</b><br><b>httpao_total_time_cache_miss_https</b> | For HTTP/S, total time for HTTP AO cache misses.                                                                                                                                                          |
| <b>Connections: Active, Dropped, Incomplete, Pending</b>                         |                                                                                                                                                                                                           |
| <b>active connections</b>                                                        | Number of WAN side connections currently established and either in use or free for fast connection use.                                                                                                   |
| <b>active_https_connections</b>                                                  | Number of active HTTPS connections.                                                                                                                                                                       |
| <b>maximum_active_connections</b>                                                | Maximum value reached by the Current Active Connections counter. Maximum Active Connections is reset if the accelerator is restarted or if statistics are cleared.                                        |
| <b>dropped_connections</b>                                                       | Number of connections dropped for any reason other than client/server socket errors or close (for example, out of resources).                                                                             |

| Report Column Heading                                     | Description                                                                                                                                                                                                                                                                                                    |
|-----------------------------------------------------------|----------------------------------------------------------------------------------------------------------------------------------------------------------------------------------------------------------------------------------------------------------------------------------------------------------------|
| <b>incomplete_connect</b>                                 | Number of SSL CONNECT requests with an incomplete message.                                                                                                                                                                                                                                                     |
| <b>pending_connections</b>                                | Number of connections pending to be accepted.                                                                                                                                                                                                                                                                  |
| <b>Connections: Handled, Optimized, Prepositioned</b>     |                                                                                                                                                                                                                                                                                                                |
| <b>handled_connections</b>                                | Number of connections handled since the accelerator was started or its statistics were last reset; incremented when a connection is accepted or re-used; never decremented.                                                                                                                                    |
| <b>handled_https_connections</b>                          | Number of HTTPS connections handled since the accelerator was started or its statistics were last reset; incremented when a connection is accepted or re-used; never decremented.                                                                                                                              |
| <b>optimized_connections</b>                              | Number of connections previously and currently optimized by the accelerator.                                                                                                                                                                                                                                   |
| <b>total_optimized_connections_https</b>                  | For HTTPS, the total number of optimized connections.                                                                                                                                                                                                                                                          |
| <b>Optimized Single Sided Connections</b>                 | Number of optimized connections using single-sided mode.                                                                                                                                                                                                                                                       |
| <b>preposition connections</b>                            | Number of prepositioned connections.                                                                                                                                                                                                                                                                           |
| <b>Opt TCP Only Connections</b>                           | Number of current active connections using TFO optimization only.                                                                                                                                                                                                                                              |
| <b>optimized TCP Plus Connections</b>                     | Number of current active connections using DRE/LZ compression/optimization or handled by an accelerator.                                                                                                                                                                                                       |
| <b>Connections: Idle, Reused, Timeout</b>                 |                                                                                                                                                                                                                                                                                                                |
| <b>idle</b>                                               | Number of Current Active Connections that are idle and available for reuse as a fast connection. Incremented when an in-use active connection becomes idle and is available for reuse as a fast connection; decremented an available idle active connection is reused or its idle timeout (5 secs) is reached. |
| <b>reused</b>                                             | Number of times a client-side idle active WAN connection was able to be reused instead of establishing a new WAN connection.                                                                                                                                                                                   |
| <b>reuse_failed</b>                                       | Number of times a client-side idle active WAN connection was attempted to be re-used but the reuse failed.                                                                                                                                                                                                     |
| <b>max_reused</b>                                         | Maximum number of times a single connection was reused. This is the “best case” of number of reuses on a single connection.                                                                                                                                                                                    |
| <b>reused_peer</b>                                        | Number of times a peer WAAS device connection was reused instead of establishing a new connection.                                                                                                                                                                                                             |
| <b>http_time_saved_fast_reuse</b>                         | Time saved by fast connection reuse.                                                                                                                                                                                                                                                                           |
| <b>ao_syn_hndling_timeouts</b>                            | Number of SYN (synchronize/start) timeouts because the AO accelerator was temporarily busy.                                                                                                                                                                                                                    |
| <b>Connections: Handoffs, Pass Through, Piped Through</b> |                                                                                                                                                                                                                                                                                                                |

| Report Column Heading                                                                              | Description                                                                                                                                                                                                          |
|----------------------------------------------------------------------------------------------------|----------------------------------------------------------------------------------------------------------------------------------------------------------------------------------------------------------------------|
| <b>handoff_failed</b>                                                                              | Number of connections attempted to be handed off but the handoff failed.                                                                                                                                             |
| <b>ssl_handoff</b>                                                                                 | Number of connections handed off to the SSL accelerator as a result of SSL CONNECT requests received by the HTTP accelerator.                                                                                        |
| <b>total_handoff</b>                                                                               | Total number of connections handed off.                                                                                                                                                                              |
| <b>PT Config Connections</b>                                                                       | Number of pass-through connections offloaded due to missing policy configurations.                                                                                                                                   |
| <b>PT Intermediate Connections</b>                                                                 | Number of pass-through connections due to an intermediate WAAS node.                                                                                                                                                 |
| <b>PT Other Connections</b>                                                                        | Number of pass-through connections offloaded due to other reasons.                                                                                                                                                   |
| <b>PT No Peer Connections</b>                                                                      | Number of pass-through connections offloaded due to the absence of a peer WAAS node.                                                                                                                                 |
| <b>pipe_through_connections</b>                                                                    | Number of connections bypassed by the SSL accelerator due to, for example, SSL cipher negotiated on the flow is not supported on the WAAS device, or the destination domain did not match domains to be accelerated. |
| <b>pipe_through_uncompressed</b>                                                                   | The number of connections bypassed                                                                                                                                                                                   |
| <b>DRE and LZ Compression</b>                                                                      |                                                                                                                                                                                                                      |
| <b>httpao_dre_hints_flush</b><br><b>httpao_dre_hints_flush_https</b>                               | For HTTP/S, number of DRE hints by SMB accelerator to flush data.                                                                                                                                                    |
| <b>httpao_dre_hints_skip_bytes</b><br><b>httpao_dre_hints_skip_bytes_https</b>                     | For HTTP/S, number of DRE hints by SMB accelerator to skip the header bytes.                                                                                                                                         |
| <b>httpao_dre_hints_skip_lz</b><br><b>httpao_dre_hints_skip_lz_https</b>                           | Number of DRE hints by SMB accelerator to skip LZ compression.                                                                                                                                                       |
| <b>httpao_accept_encoding_removed</b><br><b>httpao_accept_encoding_removed_https</b>               | Number of HTTP/S requests with Accept-Encoding removed from the HTTP/S header (preventing the server from compressing HTTP/S data and allowing the WAE to apply its own compression).                                |
| <b>Locally Served and Remotely Served</b>                                                          |                                                                                                                                                                                                                      |
| <b>httpao_locally_served_if_not_modified</b><br><b>httpao_locally_served_if_not_modified_https</b> | Number of locally served HTTP/S Not Modified (304) responses.                                                                                                                                                        |
| <b>httpao_locally_served_redirect</b><br><b>httpao_locally_served_redirect_https</b>               | Number of locally served HTTP Redirect (301) responses.                                                                                                                                                              |
| <b>httpao_locally_served_unauthorized</b><br><b>httpao_locally_served_unauthorized_https</b>       | Number of locally served HTTP/S Unauthorized (401) responses.                                                                                                                                                        |
| <b>httpao_remotely_served_if_not_modified</b>                                                      | Number of remotely served Not Modified (304) responses (cache misses).                                                                                                                                               |
| <b>httpao_remotely_served_redirect</b>                                                             | Number of remotely served Redirect (301) responses (cache misses).                                                                                                                                                   |

| Report Column Heading                                                                            | Description                                                                                                            |
|--------------------------------------------------------------------------------------------------|------------------------------------------------------------------------------------------------------------------------|
| <b>httpao_remotely_served_unauthorized</b>                                                       | Number of remotely served Unauthorized (401) responses (cache misses).                                                 |
| <b>Round Trip Time (RTT)</b>                                                                     |                                                                                                                        |
| <b>setup_rtt</b>                                                                                 | The initial RTT time, in milliseconds.                                                                                 |
| <b>rtt</b>                                                                                       | Round trip time saved for all WAN connections that have been established.                                              |
| <b>http_if_not_modified_cache_saved_rtt</b><br><b>http_if_not_modified_cache_saved_rtt_https</b> | For HTTP/S, round trip time saved by caching and locally serving Not Modified (304) responses, in milliseconds.        |
| <b>http_redirect_cache_saved_rtt</b><br><b>http_redirect_cache_saved_rtt_https</b>               | For HTTP/S, round trip time saved by caching and locally serving Redirected (301) responses.                           |
| <b>http_unauth_cache_saved_rtt</b><br><b>http_unauth_cache_saved_rtt_https</b>                   | For HTTP/S, round trip time saved by caching and locally serving Unauthorized (401) responses.                         |
| <b>total_rtt_saved_all_caches_https</b>                                                          | Total round trip time saved for all response types.                                                                    |
| <b>httpao_sharepoint_saved_rtt</b><br><b>httpao_sharepoint_saved_rtt_https</b>                   | For HTTP/S, total response time saved for HTTP AO in accessing SharePoint objects by enabling SharePoint optimization. |
| <b>Session</b>                                                                                   |                                                                                                                        |
| <b>httpao_move_session_to_v1_on_request</b>                                                      | The number of HTTP AO transactions moved to the NTLM Version 1 Security Model on request, for this session.            |
| <b>httpao_move_session_to_v1_on_response</b>                                                     | The number of HTTP AO transactions moved to the NTLM Version 1 Security Model on response, for this session.           |
| <b>httpao_pipelined_session</b>                                                                  | Number of HTTP AO pipelined transactions during the session.                                                           |
| <b>httpao_session_auth_required</b>                                                              | Number of HTTP AO Unauthorized (401) responses for the session.                                                        |
| <b>httpao_sharepoint_session_hit_count</b><br><b>httpao_sharepoint_session_hit_count_https</b>   | Number of HTTP/S sessions using the SharePoint optimization feature to access objects from the SharePoint server.      |
| <b>Sharepoint</b>                                                                                |                                                                                                                        |
| <b>httpao_sharepoint_saved_rtt</b><br><b>httpao_sharepoint_saved_rtt_https</b>                   | For HTTP/S, total response time saved for HTTP AO in accessing SharePoint objects by enabling SharePoint optimization. |
| <b>httpao_total_time_sharepoint_miss</b><br><b>httpao_total_time_sharepoint_miss_https</b>       | For HTTP/S, total time lost in accessing SharePoint data that is not already stored in cache.                          |
| <b>httpao_sharepoint_session_hit_count</b><br><b>httpao_sharepoint_session_hit_count_https</b>   | Number of HTTP/S sessions using the SharePoint optimization feature to access objects from the SharePoint server.      |
| <b>Throughput</b>                                                                                |                                                                                                                        |
| <b>Original Throughput In(bits/sec)</b>                                                          | Original input throughput, in bits per second.                                                                         |
| <b>Optimized Throughput Out(bits/sec)</b>                                                        | Optimized output throughput, in bits per second.                                                                       |
| <b>Original Throughput Out(bits/sec)</b>                                                         | Original output throughput, in bits per second.                                                                        |

| Report Column Heading                   | Description                                           |
|-----------------------------------------|-------------------------------------------------------|
| Optimized Throughput In(bits/sec)       | Optimized input throughput, in bits per second.       |
| Original Peak Throughput In(bits/sec)   | Original peak input throughput, in bits per second.   |
| Optimized Peak Throughput Out(bits/sec) | Optimized peak output throughput, in bits per second. |
| Original Peak Throughput Out(bits/sec)  | Original peak output throughput, in bits per second.  |
| Optimized Peak Throughput In(bits/sec)  | Optimized peak input throughput, in bits per second.  |
| <b>Transactions</b>                     |                                                       |
| httpao_handled_transaction              | Number of HTTP AO handled transactions.               |

## Managing Reports

The WAAS Central Manager allows you to edit any of the predefined reports and to create custom reports. Additionally, you can schedule reports to be generated periodically such as hourly, daily, weekly, or monthly. When a scheduled report is generated, a link to the report is e-mailed to notify the recipients.

This section contains the following topics:

- [Creating a Custom Report](#)
- [Viewing and Editing a Report](#)
- [Scheduling a Report](#)
- [Viewing or Deleting a Scheduled Report](#)

## Creating a Custom Report

A report consists of up to eight charts and tables. The system and device dashboard displays are examples of predefined reports, along with the other reports available in the Monitor menu.

Reports can be created only at the system level, not at the device level.

To create a custom report, follow these steps:

- 
- Step 1** From the WAAS Central Manager menu, choose **Monitor > Reports > Reports Central**.
  - Step 2** Click the **Create** taskbar icon. The Create Report pane appears, as shown in [Figure 15-14](#).

Figure 15-14 Create Report Pane

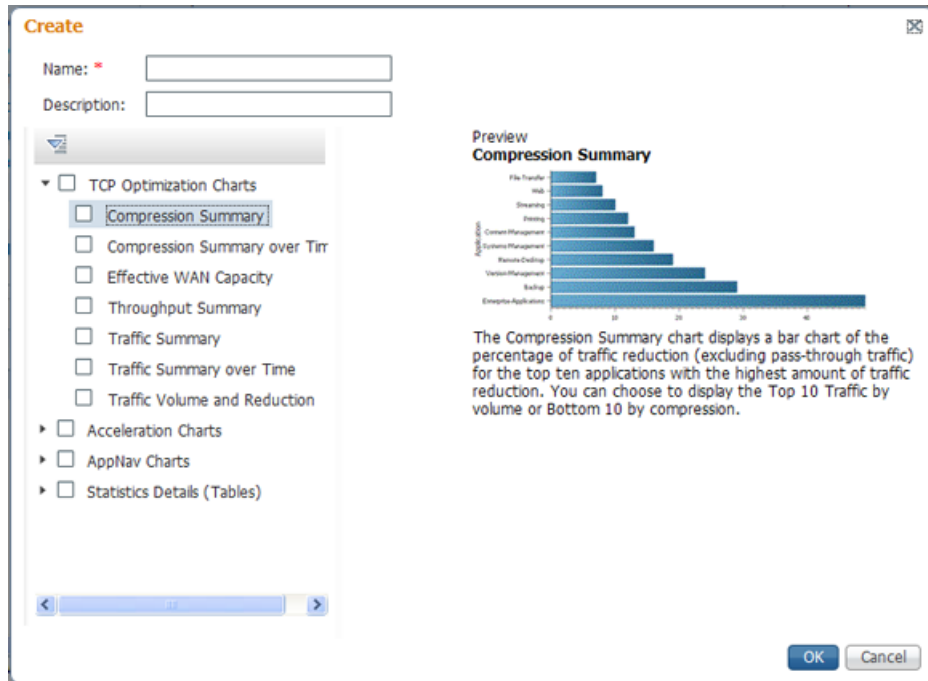

- Step 3** In the Name field, enter a name for the report. The maximum is 64 characters. Only numerals, letters, spaces, periods, hyphens, and underscores are allowed.
- Step 4** (Optional) In the Description field, enter a description of the report.
- Step 5** In the list at the left side of the pane, check the check box next to each chart and table that you want to be displayed in the report. See [WAAS Chart Descriptions](#) for a description of the charts.
- Expand the categories by clicking the small triangle next to the category name. See a preview and description of a chart by clicking the chart name. Tables are listed in the last category, Statistics Details.
- Step 6** Click **OK**.
- Step 7** (Optional) Customize any of the chart settings as follows:
- Display the report by clicking the report name in the Report Templates table.
  - You can customize report settings, such as the time frame and the time zone, as described in [Customizing a Dashboard or Report](#).
  - Click the **Edit** icon in the upper left of a chart to customize the chart settings. For more information, see [Configuring Chart Settings](#).
  - Click **OK**.
- Repeat the steps for each chart you want to customize.

Another way in which you can create a report is to copy a similar report that already exists and modify it into a new report. To copy a report, follow these steps:

- Step 1** From the WAAS Central Manager menu, choose **Monitor > Reports > Reports Central**.
- Step 2** Check the box next to the report that you want to copy.

- Step 3** Click the **Copy** taskbar icon. The copy report window appears.
  - Step 4** In the Name field, enter a name for the report.
  - Step 5** (Optional) In the Description field, enter a description of the report.
  - Step 6** Click **OK**.
- The report is added to the Reports table.
- 

## Viewing and Editing a Report

To view or edit a report, follow these steps:

- Step 1** From the WAAS Central Manager menu, choose **Monitor > Reports > Reports Central**.
  - Step 2** Click the name of the report that you want to view or edit.  
You can filter the list by choosing **Quick Filter** from the Show drop-down list and entering filter criteria.
  - Step 3** To change any of the charts or tables in the report, use the standard chart editing methods, as described in [Customizing a Dashboard or Report](#).
  - Step 4** Click **Save** to save the report, or click **Save As** to save the report under a different name.
- 

To delete a report from the Reports table, check the check box next to the corresponding report and click the **Delete** taskbar icon.

Admin users can view, edit, and delete reports created by all users and can view and edit predefined reports. Nonadmin users can view, edit, and delete only reports created by themselves, and can view and edit predefined reports.

## Scheduling a Report

You can schedule reports to be generated once or periodically, such as daily, weekly, or monthly. When a scheduled report is generated, a copy of the report can be emailed.

**Note**

You cannot delete a scheduled custom report after you have scheduled it and it is in pending status. You can delete a report only after it has been generated.

---

To schedule a report, follow these steps:

- Step 1** From the WAAS Central Manager menu, choose **Monitor > Reports > Reports Central**.
- Step 2** Check the check box next to the report that you want to schedule.
- Step 3** Click the **Schedule** icon in the taskbar. The scheduling window appears, as shown in [Figure 15-15](#).

Figure 15-15 Scheduling a Report

**Schedule Report - Network TCP Summary**

Schedule Date: 06/12/2012

Hours: 9

Minutes: 25

Frequency: Once

No. of Reports: 1 (1-1825)

Email Id: (Comma separated - 200 characters max)

Email Subject: (200 characters max)

Select: Device(s)

Select Device(s) Selected 0 | Total 2

| Name       |                          |
|------------|--------------------------|
| WAE-231-03 | <input type="checkbox"/> |
| wae-231-02 | <input type="checkbox"/> |

Show All

OK Cancel

- Step 4** In the Date field, enter the schedule date in the format DD/MM/YYYY, or click the calendar icon to display a calendar from which to choose the date.
- Step 5** In the Hours drop-down list, choose the hours. The time represents the local time at the WAAS Central Manager.
- Step 6** In the Minutes drop-down list, choose the minutes. The time represents the local time at the WAAS Central Manager.
- Step 7** In the Frequency drop-down list, choose the report frequency (Once, Hourly, Daily, Weekly, or Monthly).
- Step 8** In the No. of Reports field, enter the number of times a reoccurring report is to be generated. You can schedule it to be generated for up to 1825 times. After being generated the specified number of times, the report is no longer generated.
- Step 9** Select the **Email PDF** or **Email CSV** check box to receive the report in the format of your choice.
- Step 10** In the Email Id field (enabled only when the **Email PDF** or **Email CSV** check box is checked), enter the e-mail addresses of the report recipients, separated by commas.
- Step 11** In the Email Subject field, enter the subject of the email message.
- Step 12** From the Select drop-down list, choose an option (Device(s), DeviceGroup, Cluster, or Location) to display a list of the chosen entities.
- Step 13** In the Select entity area, choose the devices that are to be included in the statistics for the report. Check the check box next to each device, device group, cluster, or location that you want to include.
- To locate an entity in a long list, choose **Quick Filter** from the Show drop-down list and enter the complete or partial entity name in the field above the list. The search is case sensitive.
- Step 14** Click **OK**.



- Step 15** Configure the e-mail server settings for e-mail notification when reports are generated. For more information, see [Configuring the E-mail Notification Server](#) in Chapter 10, “Configuring Other System Settings.”

**Note**

In a WAAS network where there are 1000 or more WAEs, a scheduled report might take up to 4 minutes to generate. And if you schedule more than one report at the same time, the reports will be generated with a delay of up to 20 minutes, depending on the number of reports and devices.

## Viewing or Deleting a Scheduled Report

To view or delete a scheduled report, follow these steps:

- Step 1** From the WAAS Central Manager menu, choose **Monitor > Reports > Reports Central**.
- The lower part of the Reports window lists the completed and pending scheduled reports, depending on the tab you choose. (You can use the Show filter above the table to filter the reports that are displayed.)
- Step 2** (Optional) To view a completed report instance in the Completed Reports tab, click the **Completed** link in the Status column.
-  **Note** For each completed instance of a scheduled report, the Frequency column shows Once and the Completed Time shows the date and time that the report was generated.
- Step 3** (Optional) If you want to view a list of pending reports, click the **Pending Reports** tab.
- Step 4** (Optional) If you want to delete a report in either the Completed Reports or Pending Reports tabs, check the box next to one or more report instances that you want to delete and click the **Delete** taskbar icon.

WAAS stores the 10 most recently completed or failed report instances for each custom report. This number is configurable by the System.monitoring.maxReports system property. For details on changing this property, see [Modifying the Default System Configuration Properties](#) in Chapter 10, “Configuring Other System Settings.”

Admin users can view reports scheduled by all users or the name of the report creator. Nonadmin users can view only reports scheduled by themselves.

Any changes to predefined report settings are stored separately for individual users. That is, if one user changes a predefined scheduled report, only that user sees the changes, and other users (including admin users) continue to see the report with default settings.

Reports scheduled by an external user are deleted if the maximum limit of days without a login passes and the user is deleted. For more information, see the cdm.remoteuser.deletionDaysLimit system configuration property in [Chapter 10, “Configuring Other System Settings.”](#)

**Note**

You cannot delete a scheduled custom report after you have scheduled it and it is in pending status. You can delete a report only after it has been generated.

# Configuring Flow Monitoring

Flow-monitoring applications collect traffic data that is used for application trend studies, network planning, and vendor-deployment impact studies. This section describes how to configure the flow monitoring feature on the WAE, and includes the following topics:

- [Configuring Flowing Monitoring with NetQoS](#)
- [Configuring Flow Monitoring with NetFlow v9](#)
- [Troubleshooting Flow Monitoring Information](#)

## Configuring Flowing Monitoring with NetQoS

This section has the following topics:

- [About Flow Monitoring with NetQoS](#)
- [Configuration Considerations for Flow Monitoring with NetQoS](#)
- [Procedure for Configuring Flow Monitoring with NetQoS](#)
- [Example: Using NetQoS for Flow Monitoring](#)

### About Flow Monitoring with NetQoS

The NetQoS monitoring application can interoperate with the WAAS software to provide flow monitoring. To integrate this application with the WAAS software, configure the NetQoS FlowAgent module on the WAE devices. The NetQoS FlowAgent module on the WAE collects important metrics of packet flows, which are then sent across the network to the NetQoS SuperAgent. This monitoring agent analyzes the data and generates reports. For this feature to work, additional configuration is required on the NetQoS FlowAgent. (See the [Example: Using NetQoS for Flow Monitoring](#).)

The monitoring agent comprises two modules: the console (or host) and the collector. The WAE initiates two types of connections to these two monitoring agent modules: a *temporary connection to the console* and a *persistent connection to the collector*.

### Configuration Considerations for Flow Monitoring with NetQoS

Consider the following when you configure flow monitoring with NetQoS:

- Configure the console IP address on the WAE by entering the **flow monitor tcpstat-v1 host** configuration mode command in either the WAE CLI or through the Central Manager GUI. This temporary connection is referred to as the *control connection*.
- The control connection uses TCP port 7878. Its purpose is to obtain the IP address and port number of the collector to which the WAE is assigned.
- The WAE also pulls the configuration information regarding which servers are to be monitored over the control connection. After the WAE obtains the IP address and port number of the collector, the WAE opens a persistent connection to the collector. Collected summary data for the servers that are being monitored is sent over this persistent connection.
- You can place the console (or host) module and the collector module on a single device or on separate devices. These connections are independent of one another. Failure of one connection does not cause the failure of the other connection.

- You can view the state of these connections and various operation statistics display with the **show statistics flow monitor tcpstat-v1** EXEC mode command. Connection errors and data transfer errors trigger alarms on the WAE and in the Central Manager GUI. For information on flow monitoring alarms, see [Troubleshooting Flow Monitoring Information](#).
- To display debug information, use the **debug flow monitor tcpstat-v1** EXEC mode command.

## Procedure for Configuring Flow Monitoring with NetQos

To configure NetQoS flow monitoring on your WAEs using the Central Manager GUI, follow these steps:

- 
- Step 1** Create a new device group for configuring flow monitoring on multiple devices by choosing **Device Groups > device-group-name > Create New Device Group**.
    - a. When you create a device group, check the **Automatically assign all newly activated devices to this group** check box to enable this option.
    - b. Add your existing WAE devices to this new device group.
  - Step 2** In the Device Group listing window, click the **Edit** icon next to the name of the flow monitoring configuration device group that you want to configure.
  - Step 3** Choose **Configure > Monitoring > Flow Monitor**. The Flow Monitor Settings for Device Group window appears.
  - Step 4** In the Destination IP Address field, enter the IP address of the monitoring agent console.

This configuration allows the WAE to establish a temporary connection (a control connection) to the console for the purpose of obtaining the IP address of the collector device. You must configure the collector IP address information from the console device. (See the configuration documentation for the NetQoS flow monitoring application software.)
  - Step 5** Check the **Enable Flow Monitor** check box.
  - Step 6** Click **Submit** to apply the settings to the devices in this device group.
- 

To configure NetQoS flow monitoring on the WAE using the CLI, follow these steps:

- 
- Step 1** Register the WAE with the IP address of the monitoring agent console.

```
WAE(config)# flow monitor tcpstat-v1 host 10.1.2.3
```

This configuration allows the WAE to establish a temporary connection (a control connection) to the console (or host) for the purpose of obtaining the IP address of the collector device. You must configure the collector IP address information from the console device. (See the configuration documentation for the NetQoS flow monitoring application software.)
  - Step 2** Enable flow monitoring on the WAE appliance.

```
WAE(config)# flow monitor tcpstat-v1 enable
```
  - Step 3** Check the configuration by using the **show running-config** EXEC command.

## Example: Using NetQoS for Flow Monitoring

NetQoS integrates with the WAAS software by running the NetQoS FlowAgent on WAE devices. FlowAgent is a software module developed by NetQoS that resides on a WAE appliance. The FlowAgent collects metrics about the packet flows, which are then sent across the network to a NetQoS SuperAgent. The SuperAgent measures the round-trip times, server response times, and data transfer times, and then analyzes the data and generates reports.

**Note**

When you use flow monitoring with the NetQoS SuperAgent, the flow monitor on the WAE captures optimized traffic only.

To configure flow monitoring with NetQoS, follow these steps:

- Step 1** From the WAE CLI or Central Manager GUI, enter the SuperAgent Master Console IP address in the Destination IP Address field on your WAE appliances.
- If you are configuring multiple WAAS devices through a device group, wait for the configuration to propagate to all the devices in the device list.
- Step 2** From the NetQoS SuperAgent console, assign a WAE to a SuperAgent Aggregator (known as the collector in WAAS terminology) and configure the NetQoS networks, servers, and applications entities.

**Note**

For information about using the NetQoS SuperAgent Master Console and configuring NetQoS SuperAgent entities, go to <http://support.ca.com>

## Configuring Flow Monitoring with NetFlow v9

This section has the following topics:

- [About Flow Monitoring with NetFlow v9](#)
- [Configuration Considerations for Flow Monitoring with NetFlow v9](#)
- [Procedure for Configuring Flow Monitoring with NetFlow v9](#)
- [Disabling NetFlow v9](#)
- [NetFlow v9 Exported Fields](#)
- [NetFlow v9 Pass-Through Reasons](#)

## About Flow Monitoring with NetFlow v9

NetFlow v9 is a template-based protocol developed by Cisco Systems to collect IP traffic information. The NetFlow v9 record format consists of a packet header followed by a template flowset of data flowset. A template flowset contains a description of the fields to be sent through in the data flowset. A data flowset is a collection of the data records containing flow information that is put into an export packet.

WAAS v5.3.1 and later provide the following features for Netflow v9:

- Unlike NetFlow v5, which used a fixed format, NetFlow v9 utilizes a template format. All WAAS optimization engines can use this template format to export data to collectors such as Cisco Prime and Solarwinds.
- The template format allows new features to be quickly added to NetFlow v9.
- Templates are verified every few minutes for changes, and sent out hourly to provide collectors with field information for data records.
- NetFlow v9 uses WAAS transaction log information and adds an exporter code to allow data to be sent to external devices.
- NetFlow v9 can be used on all WAAS optimization engines; it is not used with WAAS AppNav.
- By default, all WAAS class maps are monitored. If you would like to have specific class maps to not be monitored, see [Disabling NetFlow v9](#).

## Configuration Considerations for Flow Monitoring with NetFlow v9

To configure NetFlow v9 on your WAEs with either the Central Manager GUI or the CLI, configure four monitoring areas:

- Flow Record—Contains the WAAS-specific flow information you want to send to the collector.
- Flow Exporter—Contains the destination details for the exported information, and the format for this information.
- Flow Monitor—Specifies which flow records are going to which flow exporter.
- Class Map—For WAAS v5.3.1 and above, monitors are enabled globally on all class map policies by default. If you do not want a particular device monitored, manually disable monitoring for that device.

## Procedure for Configuring Flow Monitoring with NetFlow v9

To configure NetFlow v9 flow monitoring on the WAE using the CLI, follow these steps:

- Step 1** Use the following command to create a flow record to configure which fields to collect as part of Netflow export:

```
WAE(config)# flow record RecordName
WAE(config)# collect waas ?
```

**Table 15-15** Collection Parameters

| Collection Parameter | Description                                |
|----------------------|--------------------------------------------|
| application-name     | Collects application name for the flow.    |
| bytes                | Collects byte counts for the flow.         |
| class-name           | Collects class name for the flow.          |
| connection-mode      | Collects connection mode for the flow.     |
| dre                  | Collects DRE details for the flow.         |
| lz                   | Collects LZ details for the flow.          |
| packets              | Collects packet counts for the flow.       |
| passthrough-reason   | Collects pass-through reason for the flow. |

- Step 2** Use the following command to create the flow exporter, which includes the destination IP address and port for the Netflow:

```
WAE(config)# flow exporter ExporterName
WAE(config-flow_exporter)# destination 2.2.2.2
WAE(config-flow_exporter)# description Descriptive name
WAE(config-flow_exporter)# export-protocol IPFIX
WAE(config-flow_exporter)# transport udp 12000
WAE(config-flow_exporter)# exit
```

- Step 3** Use the following command to create the flow monitor and associate the flow record with the flow exporter:

```
WAE(config)# flow monitor MonitorName
WAE(config-flow_monitor)# description Descriptivename
WAE(config-flow_monitor)# exporter ExporterName
WAE(config-flow_monitor)# record RecordName
WAE(config-flow_monitor)# enable
```

## Disabling NetFlow v9

By default, flow monitoring is enabled on all devices. Use the following command to disable monitoring for a particular class:

```
WAE(config)# policy-map type waas PmapName
WAE(config)# class ClassName
WAE(config)# {no} flow-monitor enable
```

## NetFlow v9 Exported Fields

In Netflow v9, there are several fields that can be provided to the Netflow collector. The following table provides some examples of these fields:

**Table 15-16 Netflow v9 Exported Fields**

| Exported Field      | Description and Corresponding Number Value                                                                                                                                     |
|---------------------|--------------------------------------------------------------------------------------------------------------------------------------------------------------------------------|
| Segment ID          | The segment of the optimized flow that the values are from: 1, 2, 4, 8, or 16. A value of 1 is the unoptimized side on the Edge WAE, and a value of 16 is a pass-through flow. |
| Source IP           | Source IP address.                                                                                                                                                             |
| Destination IP      | Destination IP address.                                                                                                                                                        |
| NextHop             | IP address of next-hop router.                                                                                                                                                 |
| Input Interface     | SNMP index of input interface.                                                                                                                                                 |
| Output Interface    | SNMP index of output interface.                                                                                                                                                |
| Source Port         | TCP/UDP source port number or equivalent.                                                                                                                                      |
| Destination Port    | TCP/UDP destination port number or equivalent.                                                                                                                                 |
| TCP Flags           | Cumulative OR of TCP flags.                                                                                                                                                    |
| Packets             | Packets in the flow.                                                                                                                                                           |
| Bytes               | Unused bytes.                                                                                                                                                                  |
| Start Time          | System uptime at start of flow.                                                                                                                                                |
| End Time            | System uptime when the last packet of the flow is received.                                                                                                                    |
| Protocol            | IP protocol type, for example, TCP=6, UDP=17.                                                                                                                                  |
| Type of Service     | Type of service.                                                                                                                                                               |
| Source ASN          | Autonomous System Number of the source, either origin or peer.                                                                                                                 |
| Destination ASN     | Autonomous System Number of the destination, either origin or peer.                                                                                                            |
| Source Mask         | Source address of the prefix mask, in bits.                                                                                                                                    |
| Destination Mask    | Destination address of the prefix mask, in bits.                                                                                                                               |
| Application Name    | Name of the application traffic on the connection.                                                                                                                             |
| Class Name          | Class name.                                                                                                                                                                    |
| Connection Mode     | Current connection mode. Value of 1 (TFO), 3 (TFO + DRE), 5 (TFO + LZ) or 7 (TFO + DRE + LZ).                                                                                  |
| Pass-Through Reason | Reason the traffic was not optimized.                                                                                                                                          |
| Bytes Received      | Number of bytes received.                                                                                                                                                      |
| Bytes Sent          | Number of bytes sent.                                                                                                                                                          |
| Packets Received    | Number of packets received.                                                                                                                                                    |
| Packets Sent        | Number of packets sent.                                                                                                                                                        |
| DRE In Bytes        | Number of DRE bytes before compression.                                                                                                                                        |
| DRE Out Bytes       | Number of DRE bytes after compression.                                                                                                                                         |
| DRE Encode Latency  | Amount of latency incurred during DRE encode operation against an optimized connection.                                                                                        |

|                    |                                                                                                   |
|--------------------|---------------------------------------------------------------------------------------------------|
| DRE Decode Latency | Amount of latency incurred during DRE decode operation against an optimized connection.           |
| LZ In Bytes        | Number of LZ bytes before compression.                                                            |
| LZ Out Bytes       | Number of LZ bytes after decompression.                                                           |
| LZ Encode Latency  | The amount of latency (transmission delay) associated with the LZ compressed message operation.   |
| LZ Decode Latency  | The amount of latency (transmission delay) associated with the LZ decompressed message operation. |
| Original Bytes     | Number of unoptimized bytes.                                                                      |
| Optimized Bytes    | Number of optimized bytes.                                                                        |

## NetFlow v9 Pass-Through Reasons

Pass-Through reasons are sent to the collector. [Table 15-17](#) shows pass-through numbers and associated reasons.

**Table 15-17** Pass-Through Number and Pass-Through Reason

| Pass-Through Number | Pass-Through Reason                 |
|---------------------|-------------------------------------|
| 0                   | PE_CONN_UNKNOWN                     |
| 1                   | PE_CONN_PT_APP_CONFIG               |
| 2                   | PE_CONN_PT_GLB_CONFIG               |
| 3                   | PE_CONN_PT_OVERLOAD                 |
| 4                   | PE_CONN_PT_CPU_OVERLOAD             |
| 5                   | PE_CONN_PT_IN_PROGRESS              |
| 6                   | PE_CONN_PT_PE_INT_ERROR             |
| 7                   | PE_CONN_PT_DYN_BYPASS               |
| 8                   | PE_CONN_INT_CLIENT                  |
| 9                   | PE_CONN_INT_SERVER                  |
| 10                  | PE_CONN_ACCEL_OPTIMIZED             |
| 11                  | PE_CONN_ACCEL_NON_OPTIMIZED         |
| 12                  | PE_CONN_APP_DYN_MITCH_OPTIMIZED     |
| 13                  | PE_CONN_APP_DYN_MITCH_NON_OPTIMIZED |
| 14                  | PE_CONN_OPT_TCP_PLUS                |
| 15                  | PE_CONN_ORIG_TCP_PLUS               |
| 16                  | PE_CONN_OPT_PREPOSITION             |
| 17                  | PE_CONN_ORIG_PREPOSITION            |
| 18                  | PE_CONN_OPT_TCP_ONLY                |
| 19                  | PE_CONN_ORIGIN_TCP_ONLY             |
| 20                  | PE_CONN_PT_NO_PEER                  |
| 21                  | PE_CONN_PT_RJCT_CAPABILITIES        |



|    |                                 |
|----|---------------------------------|
| 22 | PE_CONN_PT_RJCT_RESOURCES       |
| 23 | PE_CONN_PT_NO_LICENSE           |
| 24 | PE_CONN_PT_ASYMMETRIC           |
| 25 | PE_CONN_PT_INTERMEDIATE         |
| 26 | PE_CONN_PT_FB_INT_ERROR         |
| 27 | PE_CONN_PT_AD_INT_ERROR         |
| 28 | PE_CONN_PT_SQ_INT_ERROR         |
| 29 | PE_CONN_PT_APP_OVERRIDE         |
| 30 | PE_CONN_PT_SVR_BLACKLIST        |
| 31 | PE_CONN_PT_AD_VER_MISMATCH      |
| 32 | PE_CONN_PT_AD_AO_INCOMPAT       |
| 33 | PE_CONN_PT_AD_AOIM_PROGRESS     |
| 34 | PE_CONN_PT_DIRM_VER_MISMATCH    |
| 35 | PE_CONN_PT_DIRM_INT_ERROR       |
| 36 | PE_CONN_PT_PEER_OVERRIDE        |
| 37 | PE_CONN_PT_AD_OPT_PARSE_FAIL    |
| 38 | PE_CONN_PT_AD_SERIAL_MODE_PEER  |
| 39 | PE_CONN_PT_INTERCEPTION_ACL     |
| 40 | PE_CONN_PT_WCCP_SHUTDOWN_ACTIVE |
| 41 | PE_CONN_PT_AD_IP_FRAG           |

## Troubleshooting Flow Monitoring Information

This section has the following topics:

- [Alarms for Flow Monitoring](#)
- [Commands Used to Troubleshoot Flow Monitoring](#)

### Alarms for Flow Monitoring

Table 15-18 shows the four different alarms that may be raised when errors occur with flow monitoring.

**Table 15-18** Alarms for Flow Monitoring

| Name           | Severity | Description                                        |
|----------------|----------|----------------------------------------------------|
| CONTROL_CONN   | Major    | Indicates a problem with the control connection.   |
| COLLECTOR_CONN | Major    | Indicates a problem with the collector connection. |

| Name               | Severity | Description                                                                                                                                                                                                                                                                                                                                             |
|--------------------|----------|---------------------------------------------------------------------------------------------------------------------------------------------------------------------------------------------------------------------------------------------------------------------------------------------------------------------------------------------------------|
| SUMMARY_COLLECTION | Minor    | Indicates a problem with the collection of packet summary information.<br><br>Summary packets may be dropped because the buffer queue limit has been reached or because of a TFO (Transport File Optimization) error, such as not being able to allocate memory.<br><br>Summary packet collection may also be dependent on the available WAN bandwidth. |
| DATA_UPDATE        | Minor    | Indicates a problem with the ability of the WAE to send updates to the collector agent.                                                                                                                                                                                                                                                                 |

## Commands Used to Troubleshoot Flow Monitoring

Table 15-19 shows the commands used to troubleshoot flow monitoring.

**Table 15-19** *Commands Used to Troubleshoot Flow Monitoring*

| Command Type                     | Command                                                                                                                                          |
|----------------------------------|--------------------------------------------------------------------------------------------------------------------------------------------------|
| <b>show</b> commands             | show flow record <i>RecordName</i><br>show flow record <i>RecordName</i> template<br>show flow <i>ExporterName</i> exporter<br>show flow monitor |
| <b>show statistics</b> commands  | show statistics flow monitor <i>MonitorName</i><br>show statistics flow exporter <i>ExporterName</i>                                             |
| <b>clear statistics</b> commands | clear statistics flow monitor <i>MonitorName</i><br>clear statistics flow exporter <i>ExporterName</i>                                           |
| <b>tcpdump</b> commands          | tcpdump                                                                                                                                          |



## Troubleshooting Your WAAS Network

---

This chapter describes the troubleshooting and diagnostics tools available in the Cisco WAAS Central Manager that can help you identify and resolve issues with your WAAS system.

For additional advanced Cisco WAAS troubleshooting information, see the [Cisco WAAS Troubleshooting Guide for Release 4.1.3 and Later](#) on Cisco DocWiki. For information on flow monitoring, see [Configuring Flow Monitoring](#) in Chapter 15, “Monitoring Your WAAS Network.”



### Note

Throughout this chapter, the term Cisco WAAS device is used to refer collectively to the WAAS Central Manager and Cisco Wide Area Application Engines (WAEs) in your network. The term WAE refers to WAE and Wide Area Application Virtual Engine (WAVE) appliances, Cisco Service Ready Engine Service Module (SRE-SM) modules running WAAS, and Cisco Virtual WAAS (vWAAS) instances.

---

This chapter contains the following sections:

- [WAAS Troubleshooting Guidelines](#)
- [Gathering WAAS Troubleshooting Information](#)
- [Verifying the WAAS Image](#)
- [WAAS Central Manager Alarm Panel](#)
- [Troubleshooting Devices Using Alerts](#)
- [Using the show and clear Commands from the Central Manager](#)
- [Configuring and Viewing Logs](#)
- [Using Diagnostic Tests](#)
- [Using the Kernel Debugger](#)
- [Using WAAS TCP Traceroute](#)
- [Verifying WAAS Physical Connectivity](#)
- [Contacting Cisco Technical Support](#)

## WAAS Troubleshooting Guidelines

To troubleshoot your WAAS system, follow these general guidelines:

**Table 16-1 Troubleshooting Guidelines**

| Troubleshooting Guideline                                                                                                                                                                     | Description                                                                                                                                                                                                                                                                                                                                                                                                                                              |
|-----------------------------------------------------------------------------------------------------------------------------------------------------------------------------------------------|----------------------------------------------------------------------------------------------------------------------------------------------------------------------------------------------------------------------------------------------------------------------------------------------------------------------------------------------------------------------------------------------------------------------------------------------------------|
| 1. Maintain a consistent and recommended software version across all your WAAS devices.                                                                                                       | <ul style="list-style-type: none"> <li>If versions must differ, the Central Manager must be running the highest version. See <a href="#">Verifying the Current WAAS Image</a> to determine the version in use.</li> </ul>                                                                                                                                                                                                                                |
| 2. See the WAAS Release Note for your software version.                                                                                                                                       | <ul style="list-style-type: none"> <li>See the <a href="#">Release Note for Cisco Wide Area Application Services</a> for the latest features, operating considerations, caveats, and CLI command changes.</li> </ul>                                                                                                                                                                                                                                     |
| 3. Before you introduce configuration changes on the WAAS Central Manager, use the CMS backup feature to save your configuration.                                                             | <ul style="list-style-type: none"> <li>If you run into problems with the new configuration, you can restore the previous configuration. See the “Backing Up and Restoring your WAAS System” section in the <a href="#">Cisco Wide Area Application Services Configuration Guide</a> for the Cisco Wide Area Application Services Configuration Guide. Troubleshoot any problems with new configuration changes immediately after making them.</li> </ul> |
| 4. Verify that your configuration is correct for your network application.                                                                                                                    | <ul style="list-style-type: none"> <li>Make any required changes to the running-config file, and then test the configuration. If it is satisfactory, save it to the startup-config file using the copy running-config startup-config command.</li> </ul>                                                                                                                                                                                                 |
| 5. Enable system message logging.                                                                                                                                                             | <ul style="list-style-type: none"> <li>See <a href="#">Configuring and Viewing Logs</a>.</li> </ul>                                                                                                                                                                                                                                                                                                                                                      |
| 6. Run the diagnostic tool to verify device functionality and connectivity.                                                                                                                   | <ul style="list-style-type: none"> <li>See <a href="#">Using Diagnostic Tests</a>.</li> </ul>                                                                                                                                                                                                                                                                                                                                                            |
| 7. Verify the physical connectivity between WAAS peers and to the application servers.                                                                                                        | <ul style="list-style-type: none"> <li>See <a href="#">Verifying WAAS Physical Connectivity</a>.</li> </ul>                                                                                                                                                                                                                                                                                                                                              |
| 8. Gather information that defines the specific symptoms.                                                                                                                                     | <ul style="list-style-type: none"> <li>See <a href="#">Gathering WAAS Troubleshooting Information</a>.</li> </ul>                                                                                                                                                                                                                                                                                                                                        |
| 9. Troubleshooting other problems:                                                                                                                                                            | <ul style="list-style-type: none"> <li>For further information on problems including hardware or disk problems, or the system passing through more traffic than it is optimizing, see the <a href="#">Cisco WAAS Troubleshooting Guide for Release 4.1.3 and Later</a>.</li> </ul>                                                                                                                                                                       |
| 10. After you have determined that your troubleshooting attempts have not resolved the problem, contact the Cisco Technical Assistance Center (TAC) or your technical support representative. | <ul style="list-style-type: none"> <li>See <a href="#">Contacting Cisco Technical Support</a>.</li> </ul>                                                                                                                                                                                                                                                                                                                                                |

## Gathering WAAS Troubleshooting Information

This section contains the following topics:

- [Rebooting the WAAS Device](#)
- [Using the copy tech-support Command](#)
- [Using show Commands](#)
- [Using show Commands for WCCP Deployments](#)
- [Generating a System Report](#)
- [Capturing and Analyzing Packets](#)

## Rebooting the WAAS Device

**Caution**

Do not reboot the WAAS device unless it is absolutely necessary. Some information that is important to troubleshooting may not survive a reboot. Try to gather as much information as possible before rebooting.

## Using the copy tech-support Command

In most cases, you can gather the information you need to troubleshoot the device with the **copy tech-support** command. This command runs many **show** commands that are useful for troubleshooting, and it gathers the output into a single file.

You can redirect the output of the **copy tech-support** command to a disk file, an FTP server, or a TFTP server, using the following syntax:

```
copy tech-support { disk filename | ftp { hostname | ip-address } remotedirectory remotefilename | tftp { hostname | ip-address } remotefilename }
```

## Using show Commands

You can use several **show EXEC** commands to gather information specific to the symptoms you are observing in your device.

- **show alarms**
- **show accelerator**
- **show license**
- **show statistics connection**
- **show statistics tfo**
- **show interface**

## Using show Commands for WCCP Deployments

For WCCP deployments, use the following commands on the WAE:

- **show wccp gre**
- **show wccp routers**
- **show wccp wide-area-engine**
- **show wccp flows**
- **show egress-methods**

For WCCP deployments, use the following commands on the router or switch (for each service group, where applicable):

- **show ip wccp**
- **show ip wccp interfaces detail**
- **show ip wccp *service***

- **show ip wccp *service* detail**

For WCCP deployments when hashing is used, use the following commands on the router or switch:

- **show tcam counts**
- **show mls stat**
- **show mls netflow table detail**
- **show mls netflow ip count**
- **show mls netflow ip sw-installed count**
- **show mls netflow ip sw-installed detail**
- **show fm interface *interface\_name***

For WCCP deployments when masking used, use the following commands on the router or switch:

- **show ip wccp *service* mask**
- **show ip wccp *service* merge**
- **show tcam interface *interface\_name* acl {in | out} ip**
- **show tcam interface *interface\_name* acl {in | out} ip detail**

## Generating a System Report

A system report (sysreport) is a comprehensive report that you will need before you contact Cisco technical support. You can generate a sysreport by running the **copy sysreport** command.

The system report contains the output from many commands and logs on the system, including **show** commands, network statistics, graphs, log contents, configuration settings and statistics. It can take some time to generate a system report and it can be from 30 - 100 MB in size or larger. The system report contains many more elements than are included in the **copy tech-support** command, and is generally needed when contacting Cisco technical support.

Consider these guidelines when you generate a system report:

- Before generating a system report, use the **test** command to run the diagnostic tests so that this information is included in the system report.
- When generating a system report on a Central Manager (or standby Central Manager), you should first make a database backup by using the **cms database backup** command.
- When generating a system report, do not use any command options that limit the report to a specific time period, as this could cause information even within that time period not to be included.

To generate a sysreport and store it to an FTP server, use this form of the command:

```
copy sysreport ftp server-ip remote-directory remote-file-name
```

For example:

```
wae# copy sysreport ftp 10.10.10.5 /reports waelreport
```

## Capturing and Analyzing Packets

Capturing packets (sometimes referred to as a "TCP dump") is a useful aid in troubleshooting connectivity problems with the WAAS device or for monitoring suspicious activity.

The WAAS device can track packet information for network traffic that passes through it. The attributes of the packet are defined by an ACL. The WAAS device buffers the captured packets, and you can copy the buffered contents to a file or to a remote server. You can also display the captured packet information on your console or terminal.

Two packet capture utilities are available: **tcpdump** and **tethereal**. These commands require admin privileges.

Consider these guidelines when you use **tcpdump** or **tethereal** to capture packets:

- By default, these commands capture only the first 64 bytes of each packet. We recommend that you use the **-s 1600** option to capture full packet data.
- If you will be taking large traces, use **tcpdump** to create rolling packet captures in multiple files. (The **-C** option sets the maximum size of each captured file in KB and the **-M** option sets the maximum number of log files to create.)
- If you need to filter the packets captured, use **tethereal** with the **-R read** filter option. You can use **tcpdump** to create a large packet capture, then use **tethereal** against the captured file to perform filtering.
- Be careful when using **tcpdump** in a WCCP environment because **tcpdump** filters do not look within the GRE wrapper. You will need to use **tethereal** if you need to do that.
- With both commands, use the **-i any** option to capture all interfaces, or separate telnet sessions to capture on separate interfaces. Use **^c** (CTRL+c) to stop the packet capture.
- For detailed information on how to use **tcpdump** and **tethereal**, see the [Cisco Wide Area Application Services Command Reference](#).

There are several packet analysis tools that you can use to analyze packet capture files after you have captured them, including Wireshark, Ethereal, Microsoft Netmon and Sniffer Pro.

## Verifying the WAAS Image

This section contains the following topics:

- [Verifying the Current WAAS Image](#)
- [Verifying a Pending WAAS Image](#)

### Verifying the Current WAAS Image

Use the **show version** command to display the version of the software image that is currently running in your WAAS device. The command output includes:

- Copyright information
- Software Release number, for example:  
“Cisco Wide Area Application Services Software Release 6.2.3
- Device model and WAAS Version, for example:  
oe-vwaas-6.2.3.17
- Most recent compiled date and time
- Most recent restart date and time
- Device uptime, weeks, hours, minutes, and seconds

You can use the **show version** command from the CLI or from the WAAS Central Manager:

To use the *show version* command from the CLI:

```
wae# show version
```

To use the *show version* command from the WAAS Central Manager:

- 
- Step 1** Navigate to **Devices > DeviceName > Monitor > CLI Commands > show commands**
  - Step 2** From the show commands dropdown list, select **show version**
  - Step 3** Click **Submit**.
- 

## Verifying a Pending WAAS Image

Use the *show version pending* to verify that there is no pending software upgrade (waiting for a device reboot). You should see the message "No pending version".

You can use the show version command from the CLI or from the WAAS Central Manager:

To use the *show version pending* command from the CLI:

```
wae# show version pending
```

To use the *show version pending* command from the WAAS Central Manager:

- 
- Step 1** Navigate to **Devices > DeviceName > Monitor > CLI Commands > show commands**
  - Step 2** From the show commands dropdown list, select **show version**
  - Step 3** In the Arguments field, enter **pending**.
  - Step 4** Click **Submit**.
- 

## WAAS Central Manager Alarm Panel

This section has the following sections:

- [Viewing the Alarm Panel](#)
- [Acknowledging an Alarm](#)
- [Filtering and Sorting Alarms](#)
- [Device Alarms](#)

### Viewing the Alarm Panel

The alarm panel provides a near real-time view of incoming alarms and refreshes every two minutes to reflect updates to the system alarm database.

To view the alarms panel, click **Alarms** at the bottom right side of the Central Manager window.

Only Active alarms can be acknowledged in the alarm panel. Pending, Offline, and Inactive alarms cannot be acknowledged in the alarm panel.



The alarm panel also allows you to filter your view of the alarms in the list. Filtering allows you to find alarms in the list that match the criteria that you set.

Figure 16-1 shows the alarm panel.

**Figure 16-1 Alarm Panel**

|   | Device                              | IP Address | Status | Severity | Description                                                        | New |
|---|-------------------------------------|------------|--------|----------|--------------------------------------------------------------------|-----|
| 1 | <input type="checkbox"/> WAE-231-03 | 2.43.65.52 | Online | Major    | Cluster protocol on device cannot communicate with peer SN ("10.   | NEW |
| 2 | <input type="checkbox"/> WAE-231-03 | 2.43.65.52 | Online | Major    | WCCP router 2.43.65.1 unreachable for service id: 61.              | NEW |
| 3 | <input type="checkbox"/> WAE-231-03 | 2.43.65.52 | Online | Major    | SNG WING-Default has become unavailable                            | NEW |
| 4 | <input type="checkbox"/> WAE-231-03 | 2.43.65.52 | Online | Minor    | WCCP router 2.43.65.1 unusable for service id: 61 reason: Not reas | NEW |
| 5 | <input type="checkbox"/> WAE-231-03 | 2.43.65.52 | Online | Minor    | no_encryption_service, SR_NONE                                     | NEW |

## Acknowledging an Alarm

To acknowledge an active alarm, follow these steps:

- 
- Step 1** In the alarm panel, check the check box next to the name of the alarm that you want to acknowledge.
- Step 2** Click the **Acknowledge** taskbar icon.

The **Acknowledge Alarm Comments** dialog box that allows you to enter comments about the alarm is displayed.

- Step 3** Enter a comment and click **OK**. Alternatively, click **Cancel** to return to the alarm panel without completing the acknowledge action.

Comments enable you to share information about the cause or solution of a particular problem that caused the alarm. The comments field accepts up to 512 characters. You can use any combination of alpha, numeric, and special characters in this field.

---

## Filtering and Sorting Alarms

To filter and sort the alarms displayed in the alarm panel, follow these steps:

- 
- Step 1** From the Show drop-down list, choose one of the following filtering options:
- All
  - Quick Filter
  - Unacknowledged Alarms
  - Acknowledged Alarms

- **Alarms for *device-name*** (shown in the device context)

**Step 2** If you chose Quick Filter, enter the match criteria in one or more fields above the list.

**Step 3** To sort alarm entries, click a column header.

Entries are sorted alphabetically (in ASCII order). The sort order (ascending or descending) is indicated by an arrow in the column header.

**Step 4** Choose **All** to clear the filter.

---

## Device Alarms

Device alarms are associated with device objects and pertain to applications and services running on your WAAS devices. Device alarms are defined by the reporting application or service. Device alarms can also reflect reporting problems between the device and the WAAS Central Manager GUI. [Table 16-2](#) describes the various device alarms that can appear.

**Table 16-2** *Device Alarms for Reporting Problems*

| Alarm                             | Alarm Severity | Device Status | Description                                                                                                                                                             |
|-----------------------------------|----------------|---------------|-------------------------------------------------------------------------------------------------------------------------------------------------------------------------|
| Device is offline                 | Critical       | Offline       | The device has failed to communicate with the WAAS Central Manager.                                                                                                     |
| Device is pending                 | Major          | Pending       | The device status cannot be determined. This status can appear after a new device is registered, but before the first configuration synchronization has been performed. |
| Device is inactive                | Minor          | Inactive      | The device has not yet been activated or accepted by the WAAS Central Manager.                                                                                          |
| Device has lower software version | Minor          | Online        | The device has an earlier software version than the WAAS Central Manager, and it may not support some features.                                                         |

## Troubleshooting Devices Using Alerts

The WAAS Central Manager GUI allows you to view the alarms on each device and troubleshoot a device in the Troubleshooting Devices window.

To troubleshoot a device from the Troubleshooting Devices window, follow these steps:

---

**Step 1** From the WAAS Central Manager menu, choose **Devices > All Devices**.

**Step 2** Click the device alarm light bar in the Device Status column to view the alarms on a single device.

The Troubleshooting Devices pane appears, either in the WAAS Central Manager window or as a separate dialog box. (See [Figure 16-2](#).)

**Figure 16-2** Troubleshooting Devices Window

| Device Name     | IP Address   | Status | Severity | Alarm Information                                                                                                                                                                                         |
|-----------------|--------------|--------|----------|-----------------------------------------------------------------------------------------------------------------------------------------------------------------------------------------------------------|
| Scale-SE9808-DC | 2.76.254.129 | Online | Major    | Major: Service 61: Configured WCCP mask (src-ip-mask 0xf dst-ip-mask 0x0) is incompatible with operational mask in farm                                                                                   |
|                 |              |        | Major    | Major: Service 62: Configured WCCP mask (src-ip-mask 0x0 dst-ip-mask 0xf) is incompatible with operational mask in farm                                                                                   |
|                 |              |        | Critical | Critical: Device failed to join existing cluster as it detected potential degradation of the cluster if this device were to join. Interception path will remain down until the device exits joining state |
|                 |              |        | Major    | Major: Cluster protocol on device cannot communicate with peer SC ("2.76.82.13")                                                                                                                          |
|                 |              |        | Major    | Major: Cluster protocol on device cannot communicate with peer SC ("2.76.82.14")                                                                                                                          |

- Step 3** In the Alarm Information column, hover your mouse over an alarm message until the Troubleshooting tools contextual menu appears. The pop-up menu provides links to the troubleshooting and monitoring windows in the WAAS Central Manager GUI.
- Step 4** From the drop-down list that is displayed, choose the troubleshooting tool that you want to use, and click the link. The link takes you to the appropriate window in the WAAS Central Manager GUI. [Table 16-3](#) describes the tools available for device alarms.

You can view the Troubleshooting Devices window for all devices by choosing **Monitor > Troubleshoot > Alerts** from the global context.

**Table 16-3** Troubleshooting Tools for Device Alarms

| Item                | Navigation                                                                 | Description                                                                                                                                          |
|---------------------|----------------------------------------------------------------------------|------------------------------------------------------------------------------------------------------------------------------------------------------|
| Update Software     | Choose <i>device</i> , <b>Admin &gt; Versioning &gt; Software Update</b>   | Displays the Software Update window for this device. Appears only if the device software version is lower than that of the Central Manager.          |
| Edit/Monitor Device | Device dashboard                                                           | Displays the Device Dashboard for configuration.                                                                                                     |
| Telnet to Device    | Opens a Telnet window                                                      | Initiates a Telnet session using the device IP address.                                                                                              |
| View Device Log     | Choose <i>device</i> , <b>Admin &gt; History &gt; Logs</b>                 | Displays system message logs filtered for this device.                                                                                               |
| Run Show Commands   | Choose <i>device</i> , <b>Monitor &gt; CLI Commands &gt; show Commands</b> | Displays the device <b>show</b> command tool. For more information, see <a href="#">Using the show and clear Commands from the Central Manager</a> . |

## Using the show and clear Commands from the Central Manager

You can use the **show** and **clear** EXEC commands from either the WAAS CLI or the WAAS Central Manager. To use the **show** and **clear** command from the CLI, see the [Cisco Wide Area Application Services Command Reference](#).

To use the **show** and **clear** commands from the WAAS Central Manager, follow these steps:

- 
- Step 1** From the WAAS Central Manager menu, choose **Devices** > *device-name*.
  - Step 2** Choose **Monitor** > **CLI Commands** > **Show Commands** or **Clear Commands**.
  - Step 3** From the Command drop-down list, choose either a **show** or **clear** command.
  - Step 4** Enter arguments for the command, if any.
  - Step 5** Click **Submit** to display the command output.

A window displays the command output for that device.

---



**Note** The **show** and **clear** CLI commands that are available differ depending on the type of device that you select.

---

## Configuring and Viewing Logs

This section contains the following topics:

- [Configuring System Logging](#)
- [Configuring Transaction Logging](#)
- [Viewing the System Message Log](#)
- [Viewing the Audit Trail Log](#)
- [Viewing a Device Log](#)
- [CLI Commands for Verifying and Viewing Logs and System Image](#)

### Configuring System Logging

Use the WAAS system logging feature to set specific parameters for the system log file (syslog). This file contains authentication entries, privilege-level settings, and administrative details. The system log file is located in the system file system (sysfs) partition as /local1/syslog.txt.

To enable system logging, follow these steps:

- 
- Step 1** From the WAAS Central Manager menu, choose **Devices** > *device-name* (or **Device Groups** > *device-group-name*).
  - Step 2** Choose **Configure** > **Monitoring** > **Log Settings** > **System Log**. The System Log Settings window appears. (See [Figure 16-3](#).)

Figure 16-3 System Log Settings Window

The screenshot shows the 'System Log' configuration page in the Cisco WAE interface. The breadcrumb trail is 'Devices > WAE-231-03 > Configure > Monitoring > Log Settings > System Log'. The page title is 'System Log' and it shows 'Current applied settings from Device, WAE-231-03'. There are three main sections: 'Console Settings', 'Disk Settings', and 'Host Settings'. 'Console Settings' includes an 'Enable' checkbox and a 'Priority' dropdown menu currently set to 'warning'. 'Disk Settings' includes a checked 'Enable Disk Settings' checkbox, a 'File Name' text box containing '/local1/syslog.txt', a 'Priority' dropdown menu set to 'notice', and a 'Recycle' text box containing '10000000' with a note '(1000000-50000000)'. 'Host Settings' includes a 'Facility' dropdown menu set to 'Do Not Set'. Below these sections is a table for adding servers with columns for Hostname, Priority, Port, and Rate Limit. The table has one row with 'warning' priority and '514' port. At the bottom are 'Submit' and 'Reset' buttons. The status bar at the bottom right shows 'Alarms 0 0 5 0' and a user ID '346130'.

**Step 3** Enable system log files to be sent to the console:

- a. In the Console Settings section, check the **Enable** check box.
- b. From the Priority drop-down list, choose the severity level of the message that should be sent to the specified remote syslog host. The default priority-code is *warning* (level 4). Each syslog host is capable of receiving a different level of event messages. (See [Table 16-4](#) for a list of priority levels.)

**Step 4** Enable syslog files to be sent to a disk:

- a. In the Disk Settings section, check the **Enable Disk Settings** check box. This setting is checked by default.
- b. In the File Name field, enter a path and a filename where the syslog files will be stored on a disk.
- c. From the Priority drop-down list, choose the severity level of the message that should be sent to the specified remote syslog host. The default priority code is *warning* (level 4). Each syslog host is capable of receiving a different level of event messages. (See [Table 16-4](#) for a list of priority levels.)
- d. In the Recycle field, specify the size of the syslog file (in bytes) that can be recycled when it is stored on a disk. (The default value of the file size is 10000000.)

Whenever the current log file size surpasses the recycle size, the log file is rotated. (The default recycle size for the log file is 10,000,000 bytes.) The log file cycles through a maximum of five rotations, and each rotation is saved as *log\_file\_name.[1-5]* under the same directory as the original log.

The rotated log file is specified in the File Name field (or by using the **logging disk filename** command).

- Step 5** Enable syslog files to be sent to a host server:
- In the Host Settings section, from the Facility drop-down list, choose the appropriate facility.
  - Click the **Add Server** taskbar icon above the host server list. You can add up to four host servers to which syslog messages can be sent. For more information.
  - In the Hostname field, enter a hostname or IP address (IPv4 or IPv6) of the remote syslog host. You must specify at least one hostname if you have enabled system logging to a host.
  - From the Priority drop-down list, choose the severity level of the message that should be sent to the specified remote syslog host. The default priority code is *warning* (level 4). Each syslog host is capable of receiving a different level of event messages. (See [Table 16-4](#) for a list of priority levels.)
  - In the Port field, specify the destination port on the remote host to which the WAAS device should send the message. The default port number is 514.
  - In the Range Limit field, specify the number of messages per second that are allowed to be sent to the remote syslog host. To limit bandwidth and other resource consumption, messages to the remote syslog host can be rate limited. If this limit is exceeded, the specified remote syslog host drops the messages. There is no default rate limit, and by default, all syslog messages are sent to all of the configured syslog hosts.

- Step 6** Click **Submit**.

To configure system logging from the CLI, you can use the **logging** global configuration command.

This section contains the following topics:

- [Priority Levels](#)
- [Multiple Hosts for System Logging](#)

## Priority Levels

[Table 16-4](#) lists the different priority levels of detail that can be sent to the recipient of syslog messages for a corresponding event.

**Table 16-4** System Logging Priority Levels and Descriptions

| Priority Code | Condition   | Description                        |
|---------------|-------------|------------------------------------|
| 0             | Emergency   | System is unusable.                |
| 1             | Alert       | Immediate action needed.           |
| 2             | Critical    | Critical conditions.               |
| 3             | Error       | Error conditions.                  |
| 4             | Warning     | Warning conditions.                |
| 5             | Notice      | Normal but significant conditions. |
| 6             | Information | Informational messages.            |
| 7             | Debug       | Debugging messages.                |

Each syslog host can receive different priority levels of syslog messages. You can configure different syslog hosts with a different syslog message priority code to enable the WAAS device to send varying levels of syslog messages to the four external syslog hosts. For example, a WAAS device can be configured to send messages that have a priority code of *error* (level 3) to the remote syslog host that has an IP address of 10.10.10.1 and messages that have a priority code of *warning* (level 4) to the remote syslog host that has an IP address of 10.10.10.2.

**Note**

Setting a logging priority to Levels 1-4 can be CPU-intensive, and can generate a large amount of output.

To achieve syslog host redundancy or failover to a different syslog host, you must configure multiple syslog hosts on the WAAS device and assign the same priority code to each configured syslog host, for example, assigning a priority code of *critical* (level 2) to syslog host 1, syslog host 2, and syslog host 3.

In addition to configuring up to four logging hosts, you can also configure the following for multiple syslog hosts:

- A port number that is different from the default port number, 514, on the WAAS device to send syslog messages to a logging host.
- A rate limit for the syslog messages, which limits the rate at which messages are sent to the remote syslog server (messages per second) in order to control the amount of bandwidth used by syslog messages.

## Multiple Hosts for System Logging

Each syslog host can receive different priority levels of syslog messages. You can configure different syslog hosts with a different syslog message priority code to enable the WAAS device to send varying levels of syslog messages to the four external syslog hosts. For example, a WAAS device can be configured to send messages that have a priority code of *error* (level 3) to the remote syslog host that has an IP address of 10.10.10.1 and messages that have a priority code of *warning* (level 4) to the remote syslog host that has an IP address of 10.10.10.2.

To achieve syslog host redundancy or failover to a different syslog host, you must configure multiple syslog hosts on the WAAS device and assign the same priority code to each configured syslog host, for example, assigning a priority code of *critical* (level 2) to syslog host 1, syslog host 2, and syslog host 3.

In addition to configuring up to four logging hosts, you can also configure the following for multiple syslog hosts:

- A port number that is different from the default port number, 514, on the WAAS device to send syslog messages to a logging host.
- A rate limit for the syslog messages, which limits the rate at which messages are sent to the remote syslog server (messages per second) in order to control the amount of bandwidth used by syslog messages.

## Configuring Transaction Logging

This section contains the following topics:

- [Enabling Transaction Logging](#)
- [Transaction Logs](#)

## Enabling Transaction Logging

To enable transaction logging for TFO flows and video streams, follow these steps:

- Step 1** From the WAAS Central Manager menu, choose **Devices** > *device-name* (or **Device Groups** > *device-group-name*).
- Step 2** Choose **Configure** > **Monitoring** > **Log Settings** > **Transaction Log** for TFO transaction logging or **Configure** > **Monitoring** > **Log Settings** > **Video Acceleration Transaction Log** for video transaction logging. The Transaction Log Settings window appears. (See [Figure 16-4](#).) (The Video Transaction Log Settings window looks the same, but does not include the General Settings area at the top.)

**Figure 16-4** Transaction Log Settings Window

Transaction Log Settings for WAE, doc-waas-wae

Current settings: None (Using Factory Defaults)

**General Settings**

TFO Transaction Log Enable:

Access Control List Name:

**Archive Settings**

Max size of Archive File:  (KB) (1000-2000000)

Archive occurs:

every  (seconds) 120-604800

every hour  at  (minutes after the hour) 0-59

every  (minutes)

every day  at  (hh:mm) 0:0-23:59

every  (hours)

every week on  Sun  Mon  Tue  Wed  Thu  Fri  Sat

at:  (hh:mm) 0:0-23:59

**Export Settings**

Enable Export:

Compress Files before Export:

Export occurs:

every  (minutes) 1-10080

every hour  at  (minutes after the hour) 0-59

every  (minutes)

every day  at  (hh:mm) 0:0-23:59

every  (hours)

every week on  Sun  Mon  Tue  Wed  Thu  Fri  Sat

at:  (hh:mm) 0:0-23:59

Submit Cancel

- Step 3** Under the General Settings area title, check the **TFO Transaction Log Enable** check box to enable transaction logging. (This check box does not appear for video transaction logging.)
- The fields on the window become active.
- Step 4** (Optional) In the Access Control List Name field, enter the name of an access control list that you want to use to limit transaction logging. If you specify an access control list, only transactions from hosts that are defined in that access list are logged. (This field does not appear for video transaction logging.)
- Use the **ip access-list** global configuration command to define an access list.
- Step 5** Under the Archive Settings area title, specify values for the following fields:



- **Max Size of Archive File**—Maximum size (in kilobytes) of the archive file to be maintained on the local disk. This value is the maximum size of the archive file to be maintained on the local disk. The range is 1000 to 2000000. The default is 2000000.
- **Archive Occurs Every (interval)**—Interval at which the working log data is cleared and moved into the archive log.

**Step 6** Configure the fields in the Export Settings area to export the transaction log file to an FTP server.

Table 16-5 describes the fields in the Export Settings area.

**Table 16-5 Export Settings**

| Field                          | Function                                                                                                                                                                                                                                                                                                                                                                                                                                                                                                                                                                                                                                                                                                                                                                                                                                                                                                                                                                                                                         |
|--------------------------------|----------------------------------------------------------------------------------------------------------------------------------------------------------------------------------------------------------------------------------------------------------------------------------------------------------------------------------------------------------------------------------------------------------------------------------------------------------------------------------------------------------------------------------------------------------------------------------------------------------------------------------------------------------------------------------------------------------------------------------------------------------------------------------------------------------------------------------------------------------------------------------------------------------------------------------------------------------------------------------------------------------------------------------|
| Enable Export                  | Enables transaction logging to be exported to an FTP server.                                                                                                                                                                                                                                                                                                                                                                                                                                                                                                                                                                                                                                                                                                                                                                                                                                                                                                                                                                     |
| Compress Files before Export   | Enables compression of archived log files into gzip format before exporting them to external FTP servers.                                                                                                                                                                                                                                                                                                                                                                                                                                                                                                                                                                                                                                                                                                                                                                                                                                                                                                                        |
| Export occurs every (interval) | Interval at which the working log should be cleared by moving data to the FTP server.                                                                                                                                                                                                                                                                                                                                                                                                                                                                                                                                                                                                                                                                                                                                                                                                                                                                                                                                            |
| Export Server                  | <p>The FTP export feature can support up to four servers. Each server must be configured with a username, password, and directory that are valid for that server.</p> <ul style="list-style-type: none"> <li>• <b>Export Server</b>—The IP address or hostname of the FTP server.</li> <li>• <b>Name</b>—The user ID of the account used to access the FTP server.</li> <li>• <b>Password/Confirm Password</b>—The password of the FTP user account specified in the Name field. You must enter this password in both the Password and Confirm Password fields. Do not use the following characters: space, backward single quote ( ` ), double quote ( " ), pipe (   ), or question mark ( ? ).</li> <li>• <b>Directory</b>—The name of a working directory that will contain the transaction logs on the FTP server. The user specified in the Name field must have write permission to this directory.</li> <li>• <b>SFTP</b>—If the specified FTP server is a secure FTP server, check the <b>SFTP</b> check box.</li> </ul> |

**Step 7** Click **Submit**.

A **Click Submit to Save** message appears in red next to the Current Settings name when there are pending changes to be saved after you have applied default or device group settings. You can also revert to the previously configured settings by clicking **Reset**. The Reset button, which is visible only when you have applied default or group settings to change the current device settings, but have not yet submitted the changes.

If you try to leave this window without saving the modified settings, a dialog box with a warning message prompts you to submit the changes.



**Note** This dialog box is displayed only if you are using the Internet Explorer browser.

To enable and configure transaction logging from the CLI, use the **transaction-logs** global configuration command.

## Transaction Logs

TFO transaction logs are maintained in the local disk in the `/local1/logs/tfo` directory. Video (Windows media) logs are maintained in the `/local1/logs/wmt/wms-90` directory.

When you enable transaction logging, you can specify the interval at which the working log should be archived, by moving the data to an archive log. The archive log files are located on the local disk in the `local/local1/logs/working.log` directory.

Because multiple archive files are saved, the filename includes the time stamp of when the file was archived. Because the files can be exported to an FTP or SFTP server, the filename also contains the IP address of this WAAS device.

The archive filenames for TFO transactions use this format:

`tfo_IPADDRESS_YYYYMMDD_HHMMSS.txt`.

The archive filenames for Windows media transactions use this format:

`wms_90_IPADDRESS_YYYYMMDD_HHMMSS.txt`.

The transaction log format is documented in [Appendix B, “Transaction Log Format.”](#)

## Viewing the System Message Log

Using the system message log feature of the WAAS Central Manager GUI, you can view information about events that have occurred in your WAAS network. The WAAS Central Manager logs the messages from registered devices with a severity level of *warning*, *error*, or *fatal*.

To view logged information pertaining to your WAAS network, follow these steps:

- 
- Step 1** From the WAAS Central Manager menu, choose **Admin > Logs > System Messages**. The System Message Log window appears.



---

**Note** If no name is available for a node, “Unavailable” is displayed. This situation might occur if a node has been deleted or has been reregistered with the WAAS software.

---

- Step 2** (Optional) Choose **Quick Filter** from the Show drop-down list, and enter a value in one or more fields to filter the log to include only the entries with the specified values.
- Step 3** (Optional) Truncate the message log to ensure that not as many messages appear in the table, by completing the following steps:
- a. Click the **Truncate** icon in the taskbar. The Truncate System Message Log pane appears.
  - b. Choose one of the following options:
    - **Size Truncation**—Limits the messages in the log to the number you specify. The log uses a first in, first out process to remove old messages once the log reaches the specified number.
    - **Date Truncation**—Limits the messages in the log to the number of days you specify.
    - **Message Truncation**—Removes messages that match the specified pattern from the log.

- c. Click **OK** after you have finished specifying the truncation parameters.
- 

## Viewing the Audit Trail Log

The WAAS Central Manager logs user activity in the system. The only activities that are logged are those activities that change the WAAS network. This feature provides accountability for users' actions by describing the time and action of the task. Logged activities include the following:

- Creation of WAAS network entities
- Modification and deletion of WAAS network entities
- System configurations
- Clearing the audit log

To view audit trail logs, follow these steps:

- 
- Step 1** From the WAAS Central Manager menu, choose **Admin > Logs > Audit Trail Logs**.  
The Audit Log window appears. All the logged activities in the WAAS Central Manager are listed by user, the IP address of the machine that was used, date and time, and operation that was logged.
  - Step 2** (Optional) Choose **Quick Filter** from the Show drop-down list, and enter a value in one or more fields to filter the log to include only the entries with the specified values.
- 

## Viewing a Device Log

To view information about events that have occurred on a specific device in your WAAS network, use the system message log feature that is available in the WAAS Central Manager GUI.

To view the events that have occurred on your entire WAAS network, see [Viewing the System Message Log](#).

To view the logged information for a WAAS device, follow these steps:

- 
- Step 1** From the WAAS Central Manager menu, choose **Devices > device-name**.
  - Step 2** Choose **Admin > Logs > Device Logs**. The Device Log window appears.
  - Step 3** (Optional) Choose **Quick Filter** from the Show drop-down list, and enter a value in one or more fields to filter the log to include only the entries with the specified values.
- 

## CLI Commands for Verifying and Viewing Logs and System Image

- **Verify the WAAS image**—Use the **show version** command to display the version of the software image that is currently running in your WAAS device. This command also displays information including device model and WAE uptime.

- **Verify no pending software**—Use the **show version pending** command to verify that there is no pending software upgrade (waiting for a device reboot).
- **Verify WAAS error logging**—General system error WAAS logging to the disk file `/local1/syslog.txt` is enabled by default. Use the **show logging** command to verify that logging is enabled.
- **Enable console logging**—Use the **(config) logging console enable** command to enable logging to the console. You can set the following logging priority levels: Alert (Priority 1), Critical (Priority 2), Error (Priority 3), Warning (Priority 4), Notice (Priority 5), Information (Priority 6), and Debug (Priority 7).



---

**Note** Setting a logging priority to Levels 1-4 can be CPU-intensive, and can generate a large amount of output.

---

- **Navigating and viewing log files**—The following directories are used for WAAS log files:
  - `/local1`—Root directory for all log files and location of `syslog.txt`
  - `/local1/logs`—Service log files (admin and transaction logs)
  - `/local1/errorlog`—Service log files (debug logs)
  - `/local1/errorlog/cifs`—CIFS internal log files (for WAAS versions earlier than Version 6.x)
  - `/local1/core_dir`—Process core dump files

Use the following commands to navigate and view these log files:

- `cd`
- `pwd`
- `dir`
- `type-tail filename line follow`
- `find-pattern`

## Using Diagnostic Tests

This section includes the following topics:

- [Device Diagnostics Using the Central Manager](#)
- [Device Diagnostics Using the CLI](#)
- [Akamai Connect Diagnostics Using the Central Manager](#)

## Device Diagnostics Using the Central Manager

The WAAS Central Manager includes a troubleshooting and diagnostic reporting facility.

To perform diagnostic tests, follow these steps:

- 
- Step 1** From the WAAS Central Manager menu, choose **Devices** > *device-name* (or **Device Groups** > *device-group-name*).
- Step 2** Choose **Monitor** > **Tools** > **Diagnostics Tests**. The Diagnostic Tool window appears.

- Step 3** Check the check box next to each diagnostic test you want to run, or check the top check box, Test, to run all tests. The following tests are available:
- Device Operation—Checks the device’s status and the presence of coredump files or alarms of major or critical severity.
  - Basic Configuration—Checks the device’s basic network configuration.
  - Basic Connectivity—Checks the device’s connectivity to configured external devices (DNS, authentication, NTP servers, and so forth).
  - Physical Interface—Checks the configuration and operation of the device’s physical interfaces.



---

**Note** A Virtual Interface test is available for vWAAS devices.

---

- Configuration Security—Checks the running configuration for potentially malicious (cross-site scripting [XSS]) entries.
- Traffic Optimization—Checks the TFO configuration and operation.
- WCCP Configuration and Operation—Checks the configuration and operation of WCCP traffic interception.
- Inline configuration and operation—Checks the configuration and operation of inline group interfaces.



---

**Note** The inline configuration and operation test is not available for vWAAS devices.

---

**Step 4** Click **Run**.

**Step 5** View the test results in the lower part of the window.



---

**Note** If any of the tests fail, error messages describe the problem and provide recommended solutions.

---

You can run the same diagnostic tests again and refresh the results by clicking the **Refresh** icon in the taskbar.

To print the results, click the **Print** icon in the taskbar.

## Device Diagnostics Using the CLI

Use the **test EXEC** command to perform diagnostic and connectivity tests.

Use network-level tools to intercept and analyze packets as they pass through your network. Two of these tools are TCPdump and Tethereal, which you can access from the CLI by using the **tcpdump** and **tethereal EXEC** commands.

The WAAS device also supports multiple debugging modes, which can be reached with the **debug EXEC** command. These modes allow you to troubleshoot problems from configuration errors to print spooler problems. We recommend that you use the **debug** command only at the direction of Cisco Technical Assistance Center (TAC).

The output associated with the **debug** command is written to either the syslog file in `/local1/syslog.txt` or the debug log associated with the module in the file `/local1/errorlog/module_name-errorlog.current` file.

The output associated with the **debug accelerator** *name module* command for an application accelerator is written to the file `ao-errorlog.currentname`, where *name* is the accelerator name. The accelerator information manager debug output is written to the `aoim-errorlog.current` file.

The debug log file associated with a module will be rotated to a backup file when the current file reaches its maximum size. The backup files are named as follows: *name-errorlog.#*, where *#* is the backup file number.

For **debug** commands, system logging must be enabled. The command that enables logging, **logging disk enable**, which is a global configuration command, is enabled by default.

If a **debug** command module uses the syslog for debug output, the **logging disk priority debug** global configuration command must be configured (the default is **logging disk priority notice**).

If a **debug** command module uses the debug log for output, the output can be filtered based on a priority-level configuration for the four different levels of debug log output:

- For filtering of critical debug messages only, use the global configuration command: **logging disk priority critical**.
- For filtering of critical and error-level debug messages, use the global configuration command: **logging disk priority error**.
- For filtering of critical, error, and trace debug level debug messages, use the global configuration command: **logging disk priority debug**.
- For seeing all debug log messages, including critical, error, trace and detail messages, use the following global configuration command: **logging disk priority detail**.

Regardless of the priority-level configuration, syslog messages at the LOG\_ERROR or higher severity will be automatically written to the debug log associated with a module.

For more details on these CLI commands, see *Cisco Wide Area Application Services Command Reference*.

## Akamai Connect Diagnostics Using the Central Manager

For Cisco WAAS devices with Akamai Connect, the Akamai Diagnostics screen (Figure 16-5) provides status information for the Akamai Connect license and Akamai Connect service, and enables you to unregister or synchronize selected devices.

To use Akamai Diagnostics, follow these steps:

- 
- Step 1** From the WAAS Central Manager menu, choose **Home > Monitor > Troubleshoot > Akamai Diagnostics**.

The Akamai Diagnostics screen appears (Figure 16-5).

Figure 16-5 Akamai Diagnostics Screen

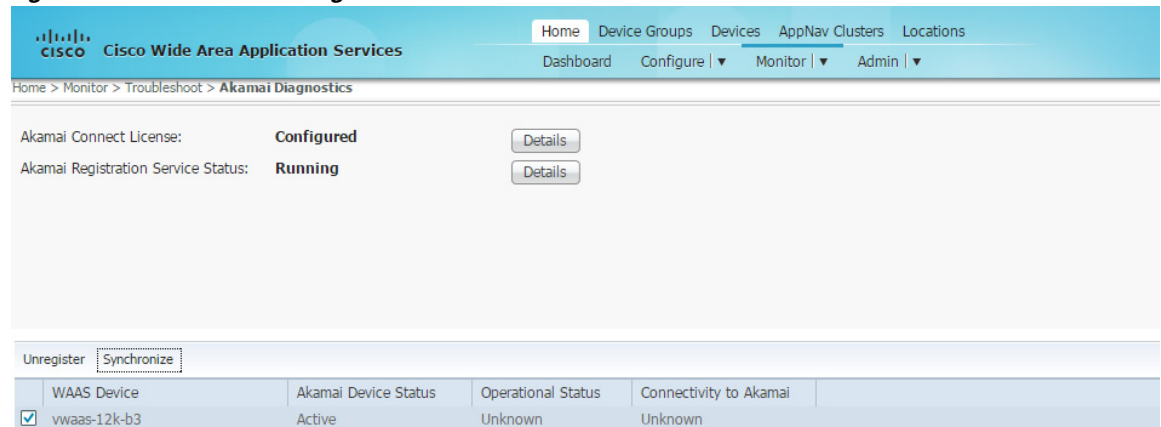

- Step 2** The upper section of the Akamai Diagnostics screen shows the Akamai Connect License status (Step 3) and the Akamai registration service status (Step 4).
- Step 3** Click the *Akamai Connect License* **Details** button to display a dialog box of additional information: The upper half of the dialog box provides details on the Akamai API credentials used by the WAAS Central Manager for this license (including API host, client ID, and customer ID). The lower half of the dialog box shows test information, with the message “Below are results of previous test. Please click “Test” button to get up-to-date results.”
- Click **Test** to test the connection to the API server.
  - A Device Registration Status table listing is displayed, showing the total number of devices, and with columns displaying each WAAS Device, Akamai ID, Akamai Device Status (ActivationInProgress or Active), and Akamai Operational Status (Disconnected, Connected, or Running).
- Step 4** Click the *Akamai Registration Service Status* **Details** button to display a dialog box that shows additional status information (including external HTTP proxy, last synchronization with Akamai, number of pending operations, and number of API errors).
- At the Akamai Registration Service Status dialog box, check the **Enable debugging Akamai API calls** check box to enable debugging of Akamai API calls. The Device Registration Service Status dialog box displays an API error log with the total number of API errors, and a table listing with columns labeled When, Device, Operation (such as Refresh All Devices), and Error Message (such as Read timed out(HTTP status code -1)).
- Step 5** The lower section of the Akamai Diagnostics screen is a table listing of WAAS devices with Akamai Connect, with columns for WAAS Device, Akamai Device Status (ActivationInProgress or Active), Operational Status (Disconnected, Connected, or Running), and Connectivity to Akamai (Disconnected, Activating, or Connected). The table heading provides two buttons: **Unregister** (Step 6) and **Synchronize** (Step 7).
- Step 6** To unregister a device from this table listing:
- Select the device(s).

- b. Click the **Unregister** button in the table heading.

The **Unregister** button triggers the removal of the device record on the Akamai server, and invalidates the entitlement key used by the Cache Engine to talk with Akamai Connect devices. The unregistered device can continue to function with transparent caching benefits, but it will not utilize Akamai Connected Cache or OTT caching benefits.

- c. When you click **Unregister**, the following warning message is displayed: “De-registering device(s) would prevent Akamai Connected Cache and OTT features from working on devices that have these features enabled. Please confirm de-registration of selected device(s).”
- d. Click **OK** to de-register to the selected device(s) or click **Cancel** to exit the procedure without de-registering the selected device(s).

- Step 7** Click the **Synchronize** button in the table heading.

- a. Synchronization between the Akamai server and the WAAS Central Manager occurs in specified time intervals automatically. The **Synchronize** button enables you to trigger synchronization between the Akamai server and all Akamai-registered WAAS devices,
- b. When you click **Synchronize**, it communicates with the Akamai server for the latest updates of all devices registered with the Central Manager, and the status of these devices is updated accordingly.

Note the following operating considerations when using the Synchronize button:

- The **Synchronize** button applies to all Akamai-enabled devices; it is not specific to a particular device update.
- You can check the last synchronization time from the Akamai Registration Service Status Details button, described in [Step 4](#).

## Using the Kernel Debugger

The WAAS Central Manager GUI allows you to enable or disable access to the kernel debugger (kdb). After being enabled, the kernel debugger is automatically activated when kernel problems occur.

To enable the kernel debugger, follow these steps:

- Step 1** From the WAAS Central Manager menu, choose **Devices > device-name** (or **Device Groups > device-group-name**).
- Step 2** Choose **Monitor > Tools > Kernel Debugger**. The Kernel Debugger window appears.
- Step 3** Check the **Enable** check box to enable the kernel debugger, and click **Submit**. (By default, this option is disabled.)

## Using WAAS TCP Traceroute

The WAAS TCP Traceroute tool can help you troubleshoot network and connection issues, including asymmetric paths. You can use it to find a list of WAAS nodes between the client and the server, and the configured and applied policies for a connection. From the Central Manager, you can choose any device in your WAAS network from which to run the traceroute.



To use the WAAS Central Manager TCP Traceroute tool, follow these steps:

- 
- Step 1** From the WAAS Central Manager menu, choose **Monitor > Troubleshoot > WAAS Tcptraceroute**. Alternatively, you can choose a device first and then choose this menu item to run the traceroute from that device.
- Step 2** From the WAAS Node drop-down list, choose a WAAS device from which to run the traceroute. (This item does not appear if you are in the device listing.)
- Step 3** In the Destination IP and Destination Port fields, enter the IP address and port of the destination for which you want to run the traceroute
- Step 4** Click **Run TCPTraceroute** to display the results.
- WAAS nodes in the traced path are displayed in the table below the fields. From the Show drop-down list, choose a filter setting to filter the devices, as needed. You can use a quick filter to filter any value, or show all devices.
- 

You can view traceroute information from the CLI by using the **waas-tcptrace EXEC** command.

Another troubleshooting tool that you can use to trace connections on a WAAS appliance ANC is the Connection Trace tool. For details, see [AppNav Connection Tracing](#) in Chapter 4, “Configuring AppNav.”

## Verifying WAAS Physical Connectivity

This section has the following topics:

- [Verifying Physical Connectivity Between Peer WAAS Devices](#)
- [Verifying Physical Connectivity Between WAAS Data Center and Application Server Hosts](#)

### Verifying Physical Connectivity Between Peer WAAS Devices

To verify physical connectivity between peer WAAS devices, follow these steps:

- 
- Step 1** Check all cable connections on the switch or router that may impact the WAAS device.
- Step 2** Use the **ping** command to send an ICMP Echo request to the peer WAE. For example:

```
WAE# ping 10.1.1.2 172.19.131.189
PING 172.19.131.189 (172.19.131.189) from 10.1.1.21 : 56(84) bytes of data.
 64 bytes from 172.19.131.189: icmp_seq=0 ttl=249 time=613 usec
 64 bytes from 172.19.131.189: icmp_seq=1 ttl=249 time=485 usec
 64 bytes from 172.19.131.189: icmp_seq=2 ttl=249 time=494 usec
 64 bytes from 172.19.131.189: icmp_seq=3 ttl=249 time=510 usec
 64 bytes from 172.19.131.189: icmp_seq=4 ttl=249 time=493 usec

--- 172.19.131.189 ping statistics ---
 5 packets transmitted, 5 packets received, 0% packet loss
 round-trip min/avg/max/mdev = 0.485/0.519/0.613/0.047 ms
```

- Step 3** If a device is one hop away and you are unable to reach the device, then ping the intermediary gateway. If the gateway is not reachable, use the **show ip routes** command to verify that the correct route is displayed.
- Step 4** If necessary, enter a static route for the gateway.

**Note**

Firewalls may block ICMP traffic, and ICMP traffic does not follow the WCCP redirection path. Therefore, using the ping command does not verify redirection or acceleration. As an alternative way to verify redirection or acceleration, we recommend that you use a third-party tool that performs a TCP-based ping.

## Verifying Physical Connectivity Between WAAS Data Center and Application Server Hosts

The procedure for verifying physical connectivity between WAAS data center and application server hosts is the same procedure as described in [Verifying Physical Connectivity Between Peer WAAS Devices](#).

## Contacting Cisco Technical Support

If you are unable to resolve a problem after using the troubleshooting suggestions in this chapter, contact the Cisco Technical Assistance Center (TAC) for assistance and further instructions. Before you call, have the following information ready to help your TAC engineer assist you as quickly as possible:

- Date that you received the WAAS hardware
- Chassis serial number
- Type of software and release number (if possible, enter the show version command)
- Maintenance agreement or warranty information
- A good problem description including:
  - What is the problem and what are the user visible symptoms?
  - Where and when it occurs
  - Error messages, alerts, and alarms seen
  - Steps to duplicate the problem
- Brief explanation of the steps that you have already taken to isolate and resolve the problem
- The diagnostic test output (see the "Running Diagnostics" section)
- A Central Manager database backup (use the cms database backup command)
- Information gathered in the "Gathering WAAS Troubleshooting Information" section.
- Topology diagrams, including network/wiring diagrams and logical diagrams
- Any other evidence of the problem such as packet captures, transaction logs, core files, WCCP show command output from routers/switches and WAEs, and other log files.

You can contact support in these ways:

- [Contact TAC](#)
- [Contact the Small Business Support Center \(SBSC\)](#)





# Configuring the Network Analysis Module

---

This chapter provides information about the integration of the Cisco Network Analysis Module (NAM) in the Wide Area Application Services (WAAS) Central Manager and describes how to configure and use the NAM.

This chapter includes the following sections:

- [Information About NAM Integration](#)
- [Prerequisites for NAM Integration](#)
- [Guidelines and Limitations for NAM Integration](#)
- [Configuring the NAM](#)
- [Monitoring and Analyzing Traffic](#)

## Information About NAM Integration

Cisco WAAS is enhanced with application performance-monitoring capabilities when you integrate the Cisco WAAS Central Manager with the NAM Traffic Analyzer software.

The NAM Traffic Analyzer software enables network managers to understand, manage, and improve how applications and services are delivered to end users by combining flow-based and packet-based analysis into one solution. With the NAM, you can perform traffic analysis of applications, hosts, and conversations, make performance-based measurements on application, server, and network latency, and use Quality of Service (QoS) metrics for network-based services and problem analysis using packet captures. The NAM includes an embedded, web-based Traffic Analyzer GUI that provides quick access to the configuration menus and presents easy-to-read performance monitoring and analysis on network traffic.

The architecture for WAAS Central Manager and NAM integration allows you to deploy NAM 5.1 in any form factor such as physical blade, or appliance.

## Prerequisites for NAM Integration

The NAM integration has the following prerequisites:

- Cisco WAAS 4.4.1 or later Central Manager is installed and configured.
- The NAM 5.1 hardware and software are installed.
- The following configurations are performed:

- HTTP or HTTPS is enabled.
- An admin web user account is created.
- A MonitorView web user account is created.
- Both the WAAS Central Manager and the client computer from which you connect to the Central Manager must be able to access the configured NAM server on the network.

For more information, see the [Cisco Catalyst 6500 Series Network Analysis Module \(NAM 3\) Installation and Configuration Guide](#), or the [Cisco Prime Network Analysis Module \(NAM\) for ISR G2 SRE Installation and Configuration Guide](#).

## Guidelines and Limitations for NAM Integration

The NAM integration feature has the following configuration guidelines and limitations:

### Supported Deployments

In WAAS v6.0.1 and later, the following types of deployments are supported:

- POC deployments
- Small and medium production networks that can be monitored by one instance of NAM ( physical blade, or appliance). In this release, only one NAM instance is supported, which means that large enterprises that require more than one NAM instance to handle their network capacity must be managed separately without the WAAS-CM integration.

### Limitations

- Certain browser settings can limit the functionality of the NAM integration. For example, if Internet Explorer privacy settings are set to the default, Medium, the integration does not work because of cookie restrictions. Specify the privacy settings as Low.
- When you print the NAM windows in PDF format, they do not produce the desired output.
- When duplicate data is reported by multiple WAE data sources, the NAM does not automatically remove duplicate data. Use the Data Source selector in the dashboards and charts to address this limitation.

## Configuring the NAM

This section includes the following topics:

- [Task Flow for Configuring the NAM](#)
- [Configuring the Basic Setup](#)
- [Configuring a Site](#)
- [Configuring a Cisco WAAS-Monitored Server](#)
- [Configuring a Data Source](#)
- [Setting Preferences for a NAM Module](#)
- [Launching the NAM User Interface](#)

## Task Flow for Configuring the NAM

This section includes the following topics:

- [Basic Configuration](#)
- [Advanced Configuration](#)

### Basic Configuration

The basic NAM configuration includes the following tasks:

- Configuring the setup (see [Configuring the Basic Setup](#)).
  - Connect to a NAM server by providing the server's IP address, protocol, and port.
  - Establish account credentials.
  - Associate a WAAS device group or WAAS Express device group with configured policies.
  - Enable Flow Agent.
- Configuring Sites—To display accurate data on charts and dashboards, every site on which WAAS is planned to be deployed must be configured on the NAM (see [Configuring a Site](#)).
  - Define sites
  - Use definition rules
  - Specify sites using subnets
- Configuring monitored servers (see [Configuring a Cisco WAAS-Monitored Server](#)).
  - Specify the servers to be monitored by the NAM using the WAAS device's flow monitoring.
  - Enabling NetFlow and flow agent data sources on the actual devices, with the NAM as the collector, to automatically create the device entries in the NAM.

### Advanced Configuration

Advanced NAM configuration includes the following tasks:

- Configuring and synchronizing user-defined Classifiers and Applications with the NAM (see [Synchronizing Classifiers and Applications](#)).
- Creating and editing an auto-created WAAS data source to monitor WAAS traffic statistics (see [Configuring a Data Source](#)).
- Changing system preferences (see [Setting Preferences for a NAM Module](#)).
- Launching the NAM user interface (see [Launching the NAM User Interface](#)).

## Configuring the Basic Setup

Only device group-level policy configurations are applicable for NAM.

- 
- Step 1** From the WAAS Central Manager menu, choose **Configure > Network Analysis Module > Basics > Setup**.
- The Setup window appears ([Figure 14-1](#)). This window allows you to configure the NAM IP address and accounts.

Figure 14-1 Setup Window

- Step 2** In the NAM Server area, provide the following information:
- Choose either **http** or **https** depending on the access that was configured during the installation of NAM.
  - Enter the hostname of the NAM server.
  - Enter the IP address of the NAM server.

**To set up a site or sites on the NAM module, perform the following steps:**

- Step 3** To use the pre-configured login credentials to access the NAM server, select the **Use Default credentials** option. Proceed to [Step 8](#).

The following preconfigured login credentials are used the Central Manager:

- Configuration user:
  - Username—admin
  - Password—admin
- MonitorView user:
  - Username—waasro
  - Password—waasrao



**Note** These credentials work only if you have configured the NAM with these details explicitly after installation.

- Step 4** In the **NAM Configuration User** field, enter the username of an existing configuration user on the NAM server.
- Step 5** In the **NAM Configuration Password** field, enter the password of the configuration user that was specified in [Step 4](#).



- Step 6** In the **NAM MonitorView User** field, enter the username of an existing collection-view user configured on the NAM server.
- Step 7** In the **NAM MonitorView Password** field, enter the password of the existing collection-view user that you specified in [Step 3](#).
- Step 8** Click the **Test Connectivity/Credentials** button, to verify if the NAM server is accessible and to check if the user credentials that you specified are valid.
- Step 9** The WAAS Integration Preferences area allows you to configure a WAAS device group to work with the NAM server:
- From the **Device Group** drop-down list, choose a device group from which Cisco WAAS applications and classifier definitions are pushed to the NAM when performing a synchronization operation.  
  
The AllWAASDevices or AllWAASExpressDevices device group is the default selection for POC deployments. For production deployments, choose a suitable device group with a subset of devices for which you require the NAM integration and APM functionality.
  - Check the **Enable Flow Agent** check box to enable sending flow agent reports from the Cisco WAAS devices in the selected device group to NAM.  
  
This check box is disabled for the WAAS Express device group because WAAS Express does not support the flow agent or flow monitor. In this scenario, you must use a NAM Performance Agent (PA) from Cisco IOS routers to view the response-time metrics. The NAM charts that display response times in the Central Manager also automatically handle the PA from routers.
  - Check the **Sync all classifiers/apps to NAM on submit** check box to initiate a classifier and application synchronization with NAM and to apply Cisco WAAS definitions automatically.
- Step 10** Click **Submit**.
- 

## Configuring a Site

A site is a collection of hosts—or network endpoints—partitioned into views that help you to monitor traffic and troubleshoot problems. These views allow you to see measurements of application performance on networks where Cisco WAAS devices are deployed and dashboards that show the traffic levels between sites and alarm levels per site. You can use other NAM features without defining any sites (the default configuration).

If you have set up sites, you can choose a particular site to view in the Interactive Report and view data relevant to that site only. In some cases, you can select both a client site and a server site to view data that pertains to the interaction between hosts at different sites.



### Note

If you configure multiple data sources for the same site, the same traffic might be accounted for more than once, which results in inflated traffic statistics. For example, if you configure the NAM to receive SPAN traffic for a particular site, and it is also receiving NetFlow records for that same site, both SPAN traffic and NetFlow records are combined into the traffic statistics. In this case, if you want to see only the statistics for a particular data source, use the Interactive Report window on the left side of the Sites window to specify both the site and data source.

---

**Note**

Classification of received data from data sources to sites is done only after the sites are configured. Any old data from these data sources (before the sites were configured) are counted under the default 'Unassigned' site.

The site definition is very flexible and can accommodate various scenarios. It is used not only for viewing data, but for data export and data retention as well. Typically, a site is defined by its subnets, but a site can also be defined using the following rules:

- Subnet (IP address prefix)
- Subnet from a data source
- Subnet from a given VLAN of a SPAN data source
- WAE device serving the site

We recommend that you define sites using subnets whenever possible.

**Note**

The same rule cannot be defined in multiple sites.

**Note**

If you are configuring a Cisco WAAS device, you must add the Cisco WAAS servers to the NAM. See [Auto Creating a New WAAS Device](#).

To display accurate data on charts and dashboards, you must configure every site on which Cisco WAAS is to be deployed on the NAM. To get a breakdown of the traffic volume and response time for each branch and data center, configure the IP subnets for all the sites that have WAAS deployed.

This section includes the following topics:

- [Definition Rules](#)
- [Viewing Defined Sites](#)
- [Defining a Site](#)
- [Detecting a Subnet](#)
- [Editing a Site](#)
- [Deleting a Site](#)

## Definition Rules

Typically, subnets alone are sufficient to define a site, for example:

```
Site Data-Center = subnet 172.20.0.0/16
```

In certain scenarios, when there are overlapping IP address spaces in the networks (for example, in private networks where hosts from different sites have the same IP addresses), you can use data sources or VLANs to differentiate the subnets, for example:

```
Site NewYork = subnet 10.11.0.0/16 from "NDE-NewYork" data source.
Site LosAngeles = subnet 10.11.0.0/16 from "NDE-LosAngeles" data source.
Site Sale-Dept = subnet 10.11.0.0/16 from VLAN 10 of "DATA PORT 1" data source.
Site Finance-Dept = subnet 10.11.0.0/16 from VLAN 12 of "DATA PORT 1" data source.
```

This section includes the following topics:

- [Specifying a Site Using WAE devices \(Cisco WAAS Data Sources\)](#)
- [Specifying a Site Using Multiple Rules](#)
- [Resolving Ambiguity \(Overlapping Site Definitions\)](#)

### Specifying a Site Using WAE devices (Cisco WAAS Data Sources)

For WAAS traffic, you can define a site associated with a WAE device without specifying the site's subnets. Simply select all of the WAAS data sources coming from the WAE devices serving that site.

Site SanJose = WAE-SJ-Client, WAE-SJ-CltWAN, and WAE-SJ-Passthrough data sources.

**Note**

We recommend that you use subnets to specify WAAS-optimized sites. Use this method only if the site's subnets cannot be determined.

### Specifying a Site Using Multiple Rules

You can define a site using a combination of multiple rules, as described in [Definition Rules](#). For example, if a site has both optimized and nonoptimized traffic, it can be defined using a combination of WAAS data sources and a subnet from a NetFlow Data Export (NDE) data source.

When you define a site using multiple data sources, ensure that those data sources do not have duplicated traffic to avoid counting the site traffic statistics twice.

### Resolving Ambiguity (Overlapping Site Definitions)

Conflicting rules are not allowed in site definitions. Of the following two scenarios, the second one is not allowed:

- 1.2.3.0/24 from SPAN1 = SiteA
- 1.2.3.0/24 from SPAN1 = SiteB

Using a prefix is the preferred method. The data source and VLAN are secondary. In the following two scenarios, the first receives higher priority:

- 1.2.3.0/24 = Site D
- WAE1-Client datasrc = Site E

The longest prefix has higher priority. It has the same data source and VLAN. In the following two scenarios, the first receives higher priority:

- 1.2.3.0/24 from SPAN1 = Site A
- 1.2.0.0/16 from SPAN1 = Site C

The more refined (specific) rule has higher priority. In the following two scenarios, the first receives higher priority.

- 1.2.3.0/24 from SPAN1 = Site A
- 1.2.3.0/24 (any datasrc) = Site D

## Viewing Defined Sites

To view a defined site, follow these steps:

---

**Step 1** From the WAAS Central Manager menu, choose **Configure > Network Analysis Module > Basics > Sites**.

The Sites window appears. The defined sites are listed in a table.

The following details are displayed:

- **Name**—Lists the name of the site.
  - **Description**—Describes what the site includes.
  - **Rule**—Lists the first rule that is assigned to the selected site. If you see ellipsis (...) next to the site rule, it means that multiple rules are created for that site. To see all the rules, click the **quick view** icon (after highlighting the site, click the small arrow on the right).
  - **Status**—Shows if the site is enabled or disabled.
- 

## Defining a Site

To define a site, follow these steps:

---

**Step 1** From the WAAS Central Manager menu, choose **Configure > Network Analysis Module > Basics > Sites**.

The Sites window appears. This window lists the sites that are set up on the NAM module.

**Step 2** Click **Create**.

The Sites Configuration window displays.

**Step 3** In the **Name** field, enter a name for the site.

**Step 4** In the **Description** field, enter a description for the site.

**Step 5** Check the **Disable Sites** check box if you want the NAM to skip this site when classifying traffic. This feature is useful if the site is no longer active, but you would still like to access historical site data in the database. Otherwise, you should delete sites that are not needed.

**Step 6** In the **Subnet** field, enter the IP address subnet (IPv4 or IPv6 address and mask); for example, 10.1.1.0/24.

**Step 7** Click the blue **i** to get information about the site rules.

**Step 8** Click **Detect** to tell the NAM to look for subnets in the traffic. See [Detecting a Subnet](#).

**Step 9** In the **Data Source** field, specify the data source from where the site traffic is coming from.



---

**Note** Leave this field blank if the site traffic is coming from multiple data sources.

---

**Step 10** In the **VLAN** field, specify the VLAN where the site traffic is coming from. This field is not valid for NDE and WAAS data sources.

Leave this field blank if the site traffic can come from multiple VLANs.

**Step 11** Click **Submit**.



---

**Note** The Unassigned site (with a description of Unclassified hosts) includes sites that do not match any of your site configurations. Sites are classified at the time the packets are processed.

---

## Detecting a Subnet

To detect a subnet, follow these steps:

---

**Step 1** Choose **Configure > Network Analysis Module > Basics > Sites > Sites Configuration**.

**Step 2** In the Sites Configuration window, click **Detect**.

The NAM looks for subnets detected within the past hour and the Subnet Configuration window is displayed. This window allows you to specify the details of the sources in which you want NAM to detect subnets.

**Step 3** In the **Subnet Mask** field, enter the subnet mask.



---

**Note** If the bit mask is less than 32, the NAM detects an IPv4 subnet. If the bit mask is between 32 and 64, the NAM detects an IPv6 subnet.

---

**Step 4** From the **Data Source** drop-down list, choose the data source in which you would like to detect subnets.

**Step 5** From the **Interface** drop-down list, choose the interface in which you would like to detect subnets.

**Step 6** In the **Filter Subnets within Network** field, enter an IPv4 or IPv6 address.

**Step 7** Check the **Unassigned site** check box to include sites that do not match any of your site configurations. Sites are classified at the time of packet processing.

**Step 8** Click **Detect**.

The NAM finds the subnets that meet the criteria that you entered.

---

## Editing a Site

To edit sites that have been created, follow these steps:



---

**Note** The Unassigned site cannot be edited or deleted.

---

---

**Step 1** Choose **Configure > Network Analysis Module > Basics > Sites**.

A list of configured sites is displayed.

**Step 2** Select the site that you want to edit.

**Step 3** Click **Edit**.

The Site Configuration window displays.

**Step 4** Edit the required field (**Name**, **Priority**, **Data Sources**, or **Prefix/Mask**).

**Step 5** Click **Submit**.

---

## Deleting a Site

To delete sites that have been created, follow these steps:



**Note** The Unassigned site cannot be deleted.

---

**Step 1** Choose **Configure > Network Analysis Module > Basics > Sites**.

A list of configured sites is displayed.

**Step 2** Select the site that you want to delete.

**Step 3** Click **Delete**.

---

## Configuring a Cisco WAAS-Monitored Server

Cisco WAAS-monitored servers specify the servers from which WAAS devices export traffic flow data to the NAM monitors. To enable WAAS monitoring, you must list the servers to be monitored by the NAM using the WAAS device's flow monitoring.



**Note** The NAM is unable to monitor WAAS traffic until you set up Cisco WAAS-monitored servers. The NAM displays the status of Cisco WAAS devices as pending until you set up Cisco WAAS-monitored servers.

---

This section includes the following topics:

- [Adding a Cisco WAAS-Monitored Server](#)
- [Deleting a Cisco WAAS-Monitored Server](#)

## Adding a Cisco WAAS-Monitored Server

To add a Cisco WAAS-monitored server, follow these steps:

---

**Step 1** Choose **Configure > Network Analysis Module > Basics > Monitored Servers**.

The WAAS Servers window appears.

**Step 2** Choose **Select All** to add all the servers, or select the required servers from the list.

**Step 3** Click **Add**.

---

## Deleting a Cisco WAAS-Monitored Server

To delete a Cisco WAAS-monitored server data source, follow these steps:

- 
- Step 1** Choose **Configure > Network Analysis Module > Basics > Monitored Servers**.  
The WAAS Servers window is displayed.
- Step 2** Choose the monitored WAAS server to delete, and click **Delete**.  
A confirmation dialog box asks you if you want to delete the selected Cisco WAAS-monitored server.
- Step 3** Click **OK** to delete the Cisco WAAS-monitored server.

## Synchronizing Classifiers and Applications

You can synchronize the WAAS classifier and application definitions with the application and application groups in the NAM. A classifier and an application in WAAS are equivalent to an application and application group respectively in the NAM. WAAS applications and classifier definitions from the device group specified during the setup configuration are matched with those in the NAM server that WAAS is connected to. WAAS classifiers can contain source and destination IP addresses while the NAM recognizes an application on the basis of port numbers. Hence, only the WAAS classifiers that contain port numbers are synchronized.

To view the results of the synchronization, follow these steps:

- 
- Step 1** Choose **Configure > Network Analysis Module > Advanced > Classifier/App Sync**.  
The **Classifier/App Sync Preferences** window appears.  
The Classifier/AppSync Preferences results are displayed under the following categories:
- **Conflicting classifiers/applications**—You can choose one or all the WAAS classifiers and applications for synchronization with the NAM. By default, all the classifier and applications are selected.
  - **NAM-only applications/application groups**—Applications and application groups in the NAM are displayed. If required, you can manually add the NAM-only applications and application group definitions in WAAS at the device-group or device levels.
- Step 2** To view the differences in classifier definitions in WAAS and the NAM, click on the arrow next to **Classifier Definition Differences**.
- Step 3** Choose the WAAS classifiers that you want to synchronize with the NAM applications and provide the required information to define the filter criteria.
- Step 4** Click **Go**.  
The differences in the definitions are displayed.
- Step 5** To view applications and application groups in the NAM, click on the arrow next to **NAM-Only Applications**. Information about the applications and application groups is displayed. If required, you can manually add these definitions in WAAS at the device-group or device levels.
- Step 6** To refresh the Classifier/App Sync page, click **Refresh**.
- Step 7** Click **Submit** to start the synchronization process.
-

## Configuring a Data Source

Data sources are the source of traffic for the NAM Traffic Analyzer. Some examples of this are physical data ports of the NAM, where you get SPAN (Switched Port Analyzer) data, a specific router or switch that sends NetFlow to the NAM, or a WAAS device segment that sends data to the NAM or ERSPAN (Encapsulated Remote Switched Port Analyzer) and that goes to the NAM's management port.

A new feature in NAM 5.0 is the auto discovery of data sources, using which you can click **Auto Create** so that the NAM can automatically discover the data sources. You can see details such as the IP addresses of devices that send packets to the NAM and the time at which the last NDE packet was received (in NAM 4.x, this feature was called Listening Mode).



### Note

If you have configured sites, you can assign data sources to that particular site. If you do assign data sources to a site, and you also configure the data sources, the two could overlap because sites can also be a primary view into data sources. If there is a mismatch between the two, you will not see any data.



### Note

We recommend that you configure a site using subnets instead of selecting a data source.

The following areas contain specific information about the types of data sources:

- SPAN
- ERSPAN
- VACL
- NetFlow
- WAAS

The NAM Data Sources window lists the data sources that are configured for that NAM module, and contains the following fields:

- Device—DATA PORT if it is a local physical port or the IP address of the learned device.
- Type—The source of traffic for the NAM.
  - DATA PORT if it is a local physical port.
  - WAAS, ERSPAN, or NETFLOW if a data stream is exported from the router, switch, or WAE device.
- Activity—Most recent activity.
- Status—ACTIVE or INACTIVE.
- Data Source—Name given to the data source.
- Data Source Details—Physical Port, or information about the data source being enabled or disabled.

This section includes the following topics:

- [Adding a Data Source for a New WAAS Device](#)
- [Auto Creating a New WAAS Device](#)
- [Editing a WAAS Data Source](#)
- [Deleting a WAAS Data Source](#)



## Adding a Data Source for a New WAAS Device

The NAM uses WAAS data sources to monitor traffic that is collected from different WAAS segments: Client, Client WAN, Server WAN, Server, and Passthrough. Each WAAS segment is represented by a data source. You can set up the NAM to monitor and report other traffic statistics of the WAAS data sources, such as application, host, and conversation information in addition to the monitored Response Time metrics.

Adding a WAAS device is not usually necessary because export-enabled WAAS devices are detected and added automatically.

To manually add a WAAS device to the list of devices monitored by the NAM:

---

**Step 1** Choose **Configure > Network Analysis Module > Advanced > Data Sources**.

**Step 2** Click **Create**.

The NAM Data Source Configuration dialog box is displayed.

**Step 3** Choose **WAAS** from the **Types** drop-down list.

**Step 4** In the **IP** field, enter the device IP address.

**Step 5** Check the check boxes pertaining to the appropriate WAAS segments.

You can configure the WAAS data sources to monitor the following WAAS segments:

- **Client**—Configures the WAE device to export the original (LAN side) TCP flows that originated from its clients to the NAM for monitoring.
- **Client WAN**—Configures the WAE device to export the optimized (WAN side) TCP flows that originated from its clients to the NAM for monitoring.
- **Server WAN**—Configures the WAE device to export the optimized (WAN side) TCP flows from its servers to the NAM for monitoring.
- **Server**—Configures the WAE device to export the original (LAN side) TCP flows from its servers to the NAM for monitoring.
- **Passthrough**—This setting configures the WAE device to export the TCP flows that are passed through unoptimized.

**Step 6** Click **Submit** to add the new WAAS custom data source.

---

## Auto Creating a New WAAS Device

If you have numerous WAE devices, you can set up the NAM to configure newly discovered WAE devices using a predefined configuration template using the NAM Auto Config option.



**Note**

---

If most of your WAE devices are edge WAE devices, you might want to set the **auto config** option as an edge device, and manually configure the data center WAE, for example, choose the **Client** segment for monitoring.

---

To auto create a new WAAS device, follow these steps:

---

**Step 1** Choose **Configure > Network Analysis Module > Advanced > Data Sources**.

- Step 2** The Data Sources window is displayed.
- Step 3** Click **Auto Create**.  
The NAM Data Source Configuration dialog box appears.
- Step 4** Check the **WAAS** check box.
- Step 5** Check the check boxes pertaining to the required segments. See [Adding a Data Source for a New WAAS Device](#), for more information.
- Step 6** Click **Submit** to add the new WAAS custom data source.
- 

## Editing a WAAS Data Source

To edit a WAAS device's custom data source, follow these steps:

- Step 1** Choose **Configure > Network Analysis Module > Advanced > Data Sources**.  
The Data Sources window is displayed.
- Step 2** Select the WAAS device that you want to modify, and click **Edit**. The NAM Data Source Configuration dialog box is displayed.
- Step 3** Modify the segments as required.
- Step 4** Click the **Edit** button to edit the WAAS custom data source.
- 

## Deleting a WAAS Data Source

To delete a WAAS custom data source, follow these steps:

- Step 1** Choose **Configure > Network Analysis Module > Advanced > Data Sources**.  
The data sources window is displayed.
- Step 2** Select the WAAS custom data source that you want to delete, and click **Delete**.  
A confirmation dialog box asks you to confirm that you want to delete the selected WAAS monitored server.
- Step 3** Click **OK** if you want to proceed with a deletion of the WAAS custom data source.
- 

## Setting Preferences for a NAM Module

You can configure characteristics such as NAM display, audit trail, and file format preferences for a NAM module.

- Step 1** Choose **Configure > Network Analysis Module > Advanced > Preferences**.  
The Preferences window is displayed.
- Step 2** Specify the following preferences:

- **Refresh Interval** (60-3600 sec)—Amount of time between the refresh of information on dashboards.
- **Top N Entries** (1-10)—Number of colored bars on the Top N charts.
- **Perform IP Host Name Resolution**—Wherever an IP address appears, it gets translated to a hostname via a DNS lookup.
- **Data Displayed In**—Data displayed in Bytes or Bits.
- **International Notation**—Choose the way you would like the numbers to appear.
- **Audit Trail**—The Audit Trail option displays a listing of recent critical activities that have been recorded in an internal syslog log file. Syslog messages can also be sent to an external log.

**Step 3** Click **Submit** to save your configurations.

---

## Launching the NAM User Interface

You can launch the NAM user interface to perform advanced configuration and monitoring tasks.

To launch the NAM user interface:

Choose **Configure > Network Analysis Module > Advanced > Launch NAM GUI**.

A new window or a tab (depending on your browser settings) opens, displaying a NAM session that uses the existing login credentials.

## Monitoring and Analyzing Traffic

The monitoring and analyzing traffic feature provides intuitive workflows and interactive reporting capabilities.

The monitoring and analyzing dashboards allow you to view network traffic, application performance, site performance, and alarms at a glance.

This section provides information about monitoring your network traffic and analyzing the information presented, and contains the following topics:

- [Navigation](#)
- [Top Talkers Dashboard](#)
- [Throughput Dashboards](#)
- [Performance Analysis Dashboards](#)

## Navigation

This section includes the following topics:

- [Interactive Report](#)
- [Saving Filter Parameters](#)
- [Setting up a Scheduled Export](#)

## Interactive Report

On most monitoring dashboards, you can use the Interactive Report on the left column to redefine the parameters of the information displayed in the dashboards. Click the **Filter** button to change the parameters of the information that appears in the charts.

You can choose from various parameters, such as the time interval for the data being displayed.



### Note

---

An asterisk represents required fields.

---

The reporting-time interval selection changes depending upon the dashboard that you are viewing, and the NAM platform that you are using:

- The NAM appliance supports the following short term intervals: Last 5 minutes, last 15 minutes, last 1 hour, last 4 hours, and last 8 hours.
- The Branch Routers (NME-NAM) support the following short term intervals: Last 5 minutes, last 15 minutes, and last 1 hour.
- The other platforms support the following short term intervals: Last 5 minutes, last 15 minutes, last 1 hour, and last 4 hours.
- The Long Term interval selections (Last 1 day, 1 week, and 1 month) are disabled from the following dashboards: RTP Streams, Voice Call Statistics, Calls Tables, RTP Conversations, Host Conversations, Conversations, and Response Time Details Views.
- A maximum interval for up to 1 hour is supported for the following dashboards: RTP Streams, Voice Call Statistics, Calls Tables, RTP Conversations, Host Conversations, Conversations, Response Time Details Views.



### Note

---

The From and To fields are enabled only when the Time Range is set to Custom.

---

## Saving Filter Parameters

After clicking the Filter button in the Interactive Report and selecting the desired parameters, you can then save these selections with the purpose of viewing that same data at a future time.

To save filter parameters, follow these steps:

- 
- Step 1** At the Interactive Report on the monitoring dashboard, enter a name in the **Filter Name** field.  
A filter is saved only if a filter name is entered. Only saved filters are persisted across multiple login sessions.
- Step 2** Click **Submit**.  
The filter is now saved and displayed underneath the Interactive Report. You can save up to five filters.
- 

## Setting up a Scheduled Export

You can create a Scheduled Export to have the dashboards extracted regularly and sent to you in CSV or HTML format.

You can set up scheduled jobs that will generate a daily report at a specified time, in the specified interval, and then e-mail it to a specified e-mail address. You can also obtain a report on the spot by clicking **Preview**, rather than wait for the scheduled time. This report can also be sent after you preview it.

To set up a Scheduled Export, follow these steps:

- 
- Step 1** On most windows under **Network Analysis**, the Interactive Report is available on the left side of the screen. Click the **Export** button in the **Interactive Report** area.
- The **Create Scheduled Report** window is displayed.
- Step 2** From the **Export Type** drop-down list, choose **Daily** or **Weekly**.
- Step 3** From the **Export Time** drop-down list (when you would like the report delivered to you), choose **Day** and **Hour**.
- Step 4** Choose the **Report Time** (if Daily) or the **Data Time Range** (if Weekly). This is the time interval you want measured.
- The Report Time for a daily report is restricted to the current 24 hours.
- The Report Time for a weekly report is always from 5:00 p.m to 5:00 p.m. (17:00 to 17:00), for however many days chosen.
- For example, if you choose Export Type Weekly, Data Time Range Last 2 Days, and Export Time: Day Wednesday and Hour 13:00, the report will show data from Sunday at 17:00 to Tuesday at 17:00.
- If you choose Export Time: Day Wednesday and Hour 18:00, the report will show data from Monday at 17:00 to Wednesday at 17:00.
- Step 5** Enter the e-mail address to which you would like the report delivered.
- Step 6** Choose the delivery option (HTML or CSV).
- Step 7** Enter the report description, that will appear at the end of the filename of the report delivered to you.
- Step 8** Depending on the task you want to perform, perform one or more of the following tasks:
- Click **Reset** to clear the values in the dialog box.
  - Click **Preview** to preview the report.
  - Click **Submit** to submit the request for the scheduled job.
  - Click **Cancel** to close the dialog box and return to the previous screen.
- 

## Top Talkers Dashboard

This section includes the following topics:

- [Top Talkers Traffic Summary Dashboard](#)
- [Top Talkers Details](#)

## Top Talkers Traffic Summary Dashboard

The Top Talkers Traffic Summary dashboard allows you to view the Top N Applications, Top N Application Groups, Top N Hosts (In and Out), IP Distribution by Bytes, Top N DSCP, and Top N VLAN that is being monitored on your network. It provides auto monitoring of traffic from all WAAS devices. You can view the Traffic Summary Dashboard by choosing **Monitor > Network Analysis Module > Overview**.

You can use the Interactive Report on the left to filter the information for a particular site, data source, VLAN, or reporting time interval. You can specify just one type of criteria and leave the others blank, or specify all of them. You can also choose to view the rate or cumulative data from the Interactive Report.

When you log in to the NAM for the first time, the default view is the Traffic Summary dashboard, and the top data source is selected by default.

The charts shown on this dashboard are as follows:

- **Top N Applications**  
The Top N Applications Chart enables you to view the traffic rate (bytes per second or bits per second) or traffic volume (bytes or bits), depending on the Interactive Report filter selection (data rate or cumulative, respectively). When you place your cursor over the colored bar, you will see the number of bytes per second collected or the total bytes over the last time interval.
- **Top N Application Groups**  
This chart shows a detailed analysis of the Top N application groups and the traffic rate or volume for this interval. In the Interactive Report, you can select either rate or cumulative, where rate indicates the bytes per second, and cumulative indicates the total number of bytes.
- **Top N Hosts (In and Out)**  
This chart displays the traffic rate (bytes per second or bits per second) or traffic volume (bytes or bits).
- **IP Distribution by Bytes**  
This chart shows the percentages of bytes that are distributed to IP protocols, for example, IPv4 TCP.
- **Top N DSCP**  
This chart shows statistics for the top Differentiated Services Code Point (DSCP) aggregation groups.
- **Top N VLAN**  
This chart shows the Top N VLAN statistics. In this chart, you might see VLAN 0, which is for traffic that does not have any VLAN tags.

To see a chart in table format, use the View as Chart or View as Grid toggle button at the bottom right corner of the chart. Alternatively, you can also click **Show as Image** to view the image and save it as a PNG file.

When viewing the data as a Grid, the numbers are formatted according to what you have configured in the Preferences window (**Configure > Network Analysis Module > Advanced > Preferences**). In the Preferences window, you can also configure the number of Top N entries you would like to display.

## Top Talkers Details

While you are in the process of deploying WAAS devices, you can get data to assist in the WAAS planning and configuration. For information about setting up WAN traffic, see [Adding a Data Source for a New WAAS Device](#).

The Top Talkers Detail window (**Monitor > Network Analysis Module > Top Talkers Details**), assists you in the predeployment process. Use the Interactive Report window to select the traffic you want to analyze for optimization. The Interactive Report window displays the Top Applications, Top Network Links, Top Clients, and Top Servers.

## Throughput Dashboards

This section includes the following topics:

- [Network Dashboard](#)
- [Top Applications Dashboard](#)
- [Application Dashboard](#)

## Network Dashboard

The Network dashboard enables you to view LAN versus WAN throughput for WAAS users both in the incoming and outgoing directions. To view these reports, configure interface groups that comprise WAN and LAN interfaces. The displayed information represents the total data collected since the collection was created, or since the NAM was restarted. To view the Network dashboard, choose **Monitor > Network Analysis Module > Throughput > Network**.

Choose an interface group view from the Interface Selector on the left side of the window to see traffic in the charts. Click the arrow icon to the left of the NDE data source name to display all interfaces groups, and then select an interface group view. If the charts show no data, and you see the message “Interface needs to be selected,” you have not yet chosen an interface group view.

Once chose the interface group view, you see the following charts populated:

- Interface Traffic (Ingress % Utilization and Egress % Utilization)
- Top N Applications—Ingress
- Top N Applications—Egress
- Top N Hosts—Ingress
- Top N Hosts—Egress
- Top N DSCP Aggr—Ingress
- Top N DSCP Aggr—Egress

You can enter the interface speed manually through the Interface capacity table, or the speed can be auto configured if the SNMP settings for the NDE device are entered in the data source table.

## Top Applications Dashboard

In the Top Applications dashboard, you can view the top applications by traffic rate over a selected time period and for the specified site or data source or both.

Applications Over Time shows you all of the applications that have been running for a specific time period. The color-coded legend shows you what the applications are running.

If you place your cursor over any of the data points, you get more details about the exact value for each of the applications that are running.

## Application Dashboard

- In the Application window (**Monitor > Network Analysis Module > Throughput > Application**), you can see the traffic level for a given application over a selected period of time. It is available under the . This window shows you the following:
  - A graph of application traffic over time.
  - Top hosts that transmit and receive traffic on that application for a selected time period.
  - Application Configuration that shows the criteria by which the NAM classifies packets as that application. This criteria is typically a list of TCP or UDP ports or both that identify the application.



**Note**

---

Note that some applications are identified by heuristic or other state-based algorithms.

---

## Performance Analysis Dashboards

This section includes the following topics:

- [Application Dashboard](#)
- [Conversation Multiple Segments Dashboard](#)

## Application Dashboard

The Application dashboard provides the transaction time performance for an application as well as the original and optimized traffic volume reported by the flow agent. Information about how the transaction time is broken up across client, WAN, and server segments is also provided. For example, if the transaction time is dominated by the server segment time (due to a slow server), WAAS may not be able to improve the performance as much as when it is dominated by WAN network time. To view the Application performance analysis dashboard, choose **Monitor > Network Analysis Module > Performance Analysis > Application**.

The charts that are available on this dashboard are as follows:

- Transaction Time (Client Experience)
- Traffic Volume and Compression Ratio
- Average Concurrent Connections (Optimized vs. Passthru)
- Multi-Segment Network Time (Client LAN - WAN - Server LAN)

## Conversation Multiple Segments Dashboard

The Conversation Multiple Segments dashboard correlates data from different data sources, and allows you to view and compare response time metrics from multiple WAAS segments (data sources). To view the Conversation Multiple Segments dashboard, choose **Monitor > Network Analysis Module > Performance Analysis > Conversation Multisegments**.



The Response Time Across Multiple Segments window shows the response time metrics of the selected server or client-server pair from applicable data sources.





# Configuring SNMP Monitoring

---

This chapter describes how to configure Simple Network Management Protocol (SNMP) traps, recipients, community strings, group associations, user security model groups, and user access permissions.



**Note**

---

Throughout this chapter, the term Cisco WAAS device is used to refer collectively to the WAAS Central Manager and WAEs in your network. The term WAE refers to WAE appliances, WAE Network Modules (the Cisco Network Modules-WAE family of devices), and Cisco Services Ready Engine service modules (SRE-SM) running WAAS.

---

This chapter contains the following sections:

- [Understanding SNMP](#)
- [Cisco-Supported MIBs](#)
- [Checklist for Configuring SNMP](#)
- [Preparing for SNMP Monitoring](#)
- [Enabling SNMP Traps](#)
- [Defining SNMP Triggers to generate User-Defined Traps](#)
- [Specifying the SNMP Host](#)
- [Specifying the SNMP Community String](#)
- [Creating SNMP Views](#)
- [Creating an SNMP Group](#)
- [Creating an SNMP User](#)
- [Configuring SNMP Asset Tag Settings](#)
- [Configuring SNMP Contact Settings](#)
- [Configuring SNMP Trap Source Settings](#)

## Understanding SNMP

SNMP is an interoperable standards-based protocol that allows for external monitoring of Cisco WAAS devices through an SNMP agent.

An SNMP-managed network consists of the following primary components:

- **Managed device**—A network node that contains an SNMP agent and resides on a managed network. Managed devices include routers, access servers, switches, bridges, hubs, computer hosts, and printers. Each WAAS device running the WAAS software has an SNMP agent.
- **SNMP agent**—A software module that resides on a managed device. An agent has local knowledge of management information and translates that information into a form that is compatible with SNMP. The SNMP agent gathers data from the MIB, which is the repository for information about device parameters and network data. The agent can also send traps, or notification of certain events, to the management system.
- **Management station**—Also known as the SNMP host, the management station uses SNMP to send the agent an SNMP Get request to obtain information from the WAAS device. The managed devices then collect and store management information and use SNMP to make this information available to the management station.

Before you can access this SNMP information, you must have deployed an SNMP management application on a management station. This SNMP management station is referred to as the SNMP host because it uses SNMP to send the device agent an SNMP Get request to obtain information from the WAAS device.

This section contains the following topics:

- [SNMP Communication Process](#)
- [Supported SNMP Versions](#)
- [SNMP Security Models and Security Levels](#)
- [Enabling the SNMP Agent on a WAAS Device](#)

## SNMP Communication Process

The SNMP management station and the SNMP agent that resides on a WAAS device use SNMP to communicate as follows:

1. The SNMP management station (the SNMP host) uses SNMP to request information from the WAAS device.
2. After receiving these SNMP requests, the SNMP agent on the WAAS device accesses a table that contains information about the individual device. This table, or database, is called a MIB.



**Note** The SNMP agent on the WAAS device only initiates communication with the SNMP host under unusual conditions; it will initiate communication when it has a trap it needs to send to the host. For more information on this topic, see [Enabling SNMP Traps](#).

3. After locating the specified information in the MIB, the agent uses SNMP to send the information to the SNMP management station.

Figure 17-1 illustrates these SNMP operations for an individual WAAS device.

Figure 17-1 SNMP Components in a Cisco WAAS Network

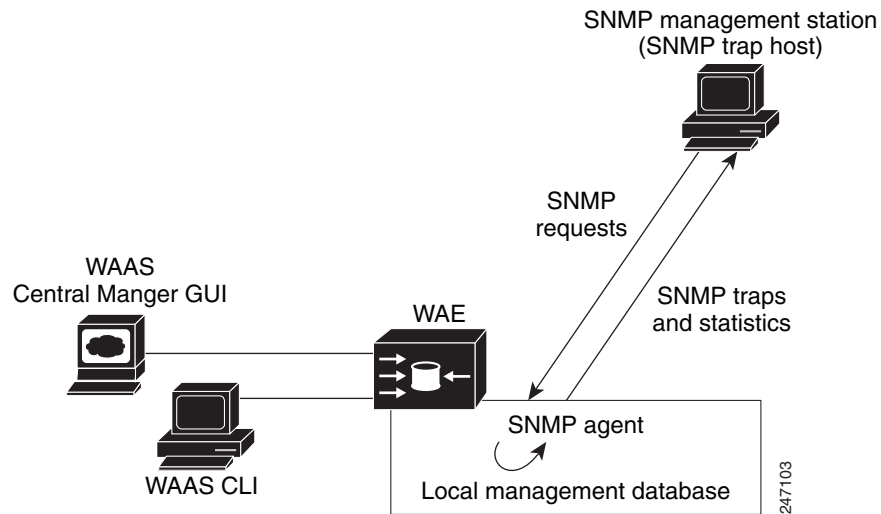

## Supported SNMP Versions

The WAAS software supports the following versions of SNMP:

- Version 1 (SNMPv1)—This is the initial implementation of SNMP. See RFC 1157 for a full description of its functionality.
- Version 2 (SNMPv2c)—This is the second release of SNMP, described in RFC 1902. It provides additions to data types, counter size, and protocol operations.
- Version 3 (SNMPv3)—This is the most recent version of SNMP, defined in RFC 2271 through RFC 2275.

Each Cisco device running WAAS software contains the software necessary to communicate information about device configuration and activity using SNMP.

## SNMP Security Models and Security Levels

SNMPv1 and SNMPv2c do not have any security (that is, authentication or privacy) features to keep SNMP packet traffic confidential. As a result, packets on the wire can be detected and SNMP community strings compromised.

To solve the security shortcomings of SNMPv1 and SNMPv2c, SNMPv3 provides secure access to WAAS devices by authenticating and encrypting packets over the network. The SNMP agent in the WAAS software supports SNMPv3 as well as SNMPv1 and SNMPv2c.

The following security features are provided in SNMPv3:

- Message integrity—Ensures that nothing has interfered with a packet during transmission.
- Authentication—Determines that the message is from a valid source.
- Encryption—Scrambles the contents of a packet to prevent it from being seen by an unauthorized source.

SNMPv3 provides security models as well as security levels. A security model is an authentication process that is set up for a user and the group in which the user resides. A security level is the permitted level of security within a security model. A combination of a security model and a security level determines which security process is used when an SNMP packet is handled. Three security models are available: SNMPv1, SNMPv2c, and SNMPv3.

Table 17-1 describes the combinations of security models and security levels.

**Table 17-1** *SNMP Security Models and Security Levels*

| Model | Level        | Authentication                                        | Encryption | Process                                                                                                                                                                                                                 |
|-------|--------------|-------------------------------------------------------|------------|-------------------------------------------------------------------------------------------------------------------------------------------------------------------------------------------------------------------------|
| v1    | noAuthNoPriv | Community string                                      | No         | Uses a community string match for user authentication.                                                                                                                                                                  |
| v2c   | noAuthNoPriv | Community string                                      | No         | Uses a community string match for user authentication.                                                                                                                                                                  |
| v3    | noAuthNoPriv | Username                                              | No         | Uses a username match for user authentication.                                                                                                                                                                          |
| v3    | AuthNoPriv   | Message Digest 5 (MD5) or Secure Hash Algorithm (SHA) | No         | Provides authentication based on the Hash-Based Message Authentication Code (HMAC)-MD5 or HMAC-SHA algorithms.                                                                                                          |
| v3    | AuthPriv     | MD5 or SHA                                            | Yes        | Provides authentication based on the HMAC-MD5 or HMAC-SHA algorithms. Provides Data Encryption Standard (DES) 56-bit encryption (packet authentication) based on the cipher block chaining (CBC)-DES (DES-56) standard. |

The SNMPv3 agent can be used in the following modes:

- noAuthNoPriv mode (that is, no security mechanisms turned on for packets)
- AuthNoPriv mode (for packets that do not have to be encrypted using the privacy algorithm [DES 56])
- AuthPriv mode (for packets that must be encrypted; privacy requires that authentication be performed on the packet)

Using SNMPv3, users can securely collect management information from their SNMP agents without worrying that the data has been tampered with. Also, confidential information, such as SNMP set packets that change a Content Engine's configuration, can be encrypted to prevent their contents from being exposed on the wire. Also, the group-based administrative model allows different users to access the same SNMP agent with varying access privileges.

## Cisco-Supported MIBs

This section contains the following topics:

- [About Cisco-Supported MIBs and CISCO-SMI](#)
- [Types of MIB Output for SNMP Monitoring](#)
- [Types of Cisco-Supported MIBs](#)
- [Downloading MIB Files](#)
- [Using MIBs to Monitor WAAS](#)

## About Cisco-Supported MIBs and CISCO-SMI

A Management Information Base (MIB) is a collection of managed objects, arranged in a hierarchical tree of MIB modules, groups, and objects:

- MIB module—Contains related MIB groups.

For example, CISCO-WAN-OPTIMIZATION-MIB contains many types of optimization groups, including **cwoAoStats** and **cwoTfoStats**.

MIB group—Contains the prefix for a set of related MIB objects, such as **cwoAoStats** (AO statistics) and **cwoTfoStats** (TFO statistics).

- MIB object—Provides information about a specific aspect of the specified MIB group.

For example:

- The **cwoAoStatsIsConfigured** MIB object indicates if the AO is configured or not.
- The **cwoTfoStatsLoadStatus** displays the current TFO load status (such as “operating normally” or “overloaded”).

The Structure of Management Information (SMI) defines the framework within which you can define or construct a MIB. The CISCO-SMI MIB group describes the structure of Cisco MIBs.

## Types of MIB Output for SNMP Monitoring

This section contains the following topics:

- [MB Output for Statistical Data](#)
- [MIB Output for Trend Data](#)

### MB Output for Statistical Data

MIB output can provide information about a device, interface, or process at a specified moment in time. [Figure 17-2](#) shows an example of MIB output of statistical data for the MIB object **cwoDreCacheStats**. This object displays DRE cache information, such as the current operational status, the portion of the disk space allocated for DRE cache, the age of the oldest data unit the data block, and the amount of data units replaced in the last hour.

**Figure 17-2** Sample MIB Output for DRE Cache Information with **cwoDreCacheStats**

```
CISCO-WAN-OPTIMIZATION-MIB::cwoDreCacheStatsStatus.0 = STRING: Usable
CISCO-WAN-OPTIMIZATION-MIB::cwoDreCacheStatsTotal.0 = Counter64: 77822 MB
CISCO-WAN-OPTIMIZATION-MIB::cwoDreCacheStatsUsed.0 = Gauge32: 96 percent
CISCO-WAN-OPTIMIZATION-MIB::cwoDreCacheStatsDataUnitUsage.0 = Counter64: 0 MB
CISCO-WAN-OPTIMIZATION-MIB::cwoDreCacheStatsReplacedOneHrDataUnit.0 = Counter64: 0 MB
CISCO-WAN-OPTIMIZATION-MIB::cwoDreCacheStatsDataUnitAge.0 = STRING: 0s
CISCO-WAN-OPTIMIZATION-MIB::cwoDreCacheStatsSigblockUsage.0 = Counter64: 1695 MB
CISCO-WAN-OPTIMIZATION-MIB::cwoDreCacheStatsReplacedOneHrSigblock.0 = Counter64: 0 MB
CISCO-WAN-OPTIMIZATION-MIB::cwoDreCacheStatsSigblockAge.0 = STRING: 14d17h
```

## MIB Output for Trend Data

The greatest value provided by MIBs may be in enabling SNMP monitoring to use the external MIB tool to gather statistics — and then provide trend data from these statistics, in either text or graphical format. This enables you to more easily identify anomalies in your WAAS network, and therefore to more effectively plan or modify your network.

For example, in the output shown in the above [Figure 17-2](#), the MIB `cwoDreCacheStatsUsed` provides information on the percentage of DRE disk space currently being used:

```
CISCO-WAN-OPTIMIZATION-MIB::cwoDreCacheStatsUsed.0 = Gauge32: 96 percent
```

If you want to monitor the trend of how DRE disk space is being used over a particular period of time, you could run the `cwoDreCacheStatsUsed` MIB for a specified time range. As shown below in [Figure 17-3](#), you could view data for a specified time range that displays the usage trend for the DRE cache disk space.

**Figure 17-3** Sample MIB Output for Percentage of DRE Disk Space Being Used

```
CISCO-WAN-OPTIMIZATION-MIB::cwoDreCacheStatsUsed.0 = Gauge32: 85 percent
CISCO-WAN-OPTIMIZATION-MIB::cwoDreCacheStatsUsed.0 = Gauge32: 91 percent
CISCO-WAN-OPTIMIZATION-MIB::cwoDreCacheStatsUsed.0 = Gauge32: 96 percent
CISCO-WAN-OPTIMIZATION-MIB::cwoDreCacheStatsUsed.0 = Gauge32: 98 percent
CISCO-WAN-OPTIMIZATION-MIB::cwoDreCacheStatsUsed.0 = Gauge32: 93 percent
```

For more information on MIB usage with SNMP monitoring, and for more examples of MIB output, see [Using MIBs to Monitor WAAS](#).

## Types of Cisco-Supported MIBs

This section describes the types of Cisco-supported MIBs, in alphabetical order by topic:

- [Akamai Connect \(CISCO-WAN-OPTIMIZATION-MIB\)](#)
- [Alarms \(CISCO-CONTENT-ENGINE-MIB\)](#)
- [AOs \(CISCO-WAN-OPTIMIZATION-MIB\)](#)
- [Applications \(CISCO-WAN-OPTIMIZATION-MIB\)](#)
- [AppNav \(CISCO-APPNAV-MIB\)](#)
- [Class Maps \(CISCO-WAN-OPTIMIZATION-MIB\)](#)
- [Configuration \(CISCO-CONFIG-MAN-MIB\)](#)
- [CPU and Memory \(CISCO-PROCESS-MIB\)](#)
- [Devices \(CISCO-CDP-MIB and CISCO-ENTITY-ASSET-MIB\)](#)
- [DRE Cache \(CISCO-WAN-OPTIMIZATION-MIB\)](#)
- [DRE Performance \(CISCO-WAN-OPTIMIZATION-MIB\)](#)
- [HTTP \(CISCO-WAN-OPTIMIZATION-MIB\)](#)
- [Interfaces \(IF-MIB\)](#)
- [IP Routing \(IP-MIB, IP-FORWARD-MIB, MIB-II\)](#)
- [MAPI \(CISCO-WAN-OPTIMIZATION-MIB\)](#)
- [NFS \(CISCO-WAN-OPTIMIZATION-MIB\)](#)



- Network Management (EVENT-MIB, HOST-RESOURCES-MIB)
- Policy Maps (CISCO-WAN-OPTIMIZATION-MIB)
- SMB (CISCO-WAN-OPTIMIZATION-MIB)
- SNMP (ENTITY, ISNMP, and SNMP MIB Groups)
- TFO (CISCO-WAN-OPTIMIZATION-MIB)

## Akamai Connect (CISCO-WAN-OPTIMIZATION-MIB)

Table 17-2 shows the Akamai Connect MIB objects associated with the **cwoAoHttpxStatsAKC** MIB object, for a specified caching mode: Standard, Basic, Bypass, or Advanced. For each Akamai Connect caching mode, there are MIB objects that provide the following types of information:

- Cache transactions—The Akamai Connect cache statistics for the total number of cache-hit transactions that were served from cache in the specified caching mode.
- Cache transactions percent—The percentage of total number of cache-hit HTTP transactions in the specified caching mode.
- Cache response time saved—The total response time saved for cache-hit HTTP transactions in the specified Akamai Connect cache mode, in milliseconds.
- Average cache response time saved—The average response time saved per cache-hit HTTP transaction in the specified Akamai Connect cache mode, in milliseconds.
- Response in bytes—The total number of response bytes saved for cache-hit HTTP transactions in the specified Akamai Connect cache mode.
- Response bytes percent—The percentage of total number of response bytes saved for cache-hit HTTP transactions in the specified Akamai Connect cache mode.
- Response time saved percent—The percentage of total response time saved for cache-hit HTTP transactions in the specified Akamai Connect cache mode.

Table 17-2 Akamai Connect MIB Objects

| MIB Object                    | Associated MIB Objects                                                                                                                                                                                                                                                                                                                                                                                                                                                                                                                                                                                                                   |
|-------------------------------|------------------------------------------------------------------------------------------------------------------------------------------------------------------------------------------------------------------------------------------------------------------------------------------------------------------------------------------------------------------------------------------------------------------------------------------------------------------------------------------------------------------------------------------------------------------------------------------------------------------------------------------|
| cwoAoHttpxStatsAKCStdEntry    | <p>Provides information about the Akamai Connect cache in <b>Standard mode</b> (default), in which Akamai Connect caches objects marked as cacheable, as well as objects with no explicit cache marker and with a last-modified date.</p> <ul style="list-style-type: none"> <li>• cwoAoHttpxStatsAKCStdCacheTrans</li> <li>• cwoAoHttpxStatsAKCStdCacheTransPercent</li> <li>• cwoAoHttpxStatsAKCStdCacheRespTimeSaved</li> <li>• cwoAoHttpxStatsAKCStdAvgCacheRespTimeSaved</li> <li>• cwoAoHttpxStatsAKCStdRespBytes</li> <li>• cwoAoHttpxStatsAKCStdRespBytesPercent</li> <li>• cwoAoHttpxStatsAKCStdRespTimeSavedPercent</li> </ul> |
| cwoAoHttpxStatsAKCBasicEntry  | <p>Provides information about the Akamai Connect cache in <b>Basic mode</b>, in which Akamai Connect caches only objects explicitly marked as cacheable.</p> <ul style="list-style-type: none"> <li>• cwoAoHttpxStatsAKCBasicCacheTrans</li> <li>• cwoAoHttpxStatsAKCBasicCacheTransPercent</li> <li>• cwoAoHttpxStatsAKCBasicRespBytes</li> <li>• cwoAoHttpxStatsAKCBasicRespBytesPercent</li> <li>• cwoAoHttpxStatsAKCBasicCacheRespTimeSaved</li> <li>• cwoAoHttpxStatsAKCBasicAvgCacheRespTimeSaved</li> <li>• cwoAoHttpxStatsAKCBasicRespTimeSavedPercent</li> </ul>                                                                |
| cwoAoHttpxStatsAKCByPassEntry | <p>Provides information about the Akamai Connect cache in <b>Bypass mode</b>, in which Akamai Connect caching is turned off for a configured site or sites.</p> <ul style="list-style-type: none"> <li>• cwoAoHttpxStatsAKCByPassCacheTrans</li> <li>• cwoAoHttpxStatsAKCByPassCacheTransPercent</li> <li>• cwoAoHttpxStatsAKCByPassCacheRespTimeSaved</li> <li>• cwoAoHttpxStatsAKCByPassAvgCacheRespTimeSaved</li> <li>• cwoAoHttpxStatsAKCByPassCacheRespTimeSavedPercent</li> <li>• cwoAoHttpxStatsAKCByPassRespBytes</li> <li>• cwoAoHttpxStatsAKCByPassRespBytesPercent</li> </ul>                                                 |

| MIB Object                   | Associated MIB Objects                                                                                                                                                                                                                                                                                                                                                                                                                                                                                                                                                                                                      |
|------------------------------|-----------------------------------------------------------------------------------------------------------------------------------------------------------------------------------------------------------------------------------------------------------------------------------------------------------------------------------------------------------------------------------------------------------------------------------------------------------------------------------------------------------------------------------------------------------------------------------------------------------------------------|
| cwoAoHttpxStatsAKCAdvEntry   | <p>Provides information about the Akamai Connect cache in <b>Advanced mode</b>, in which Akamai Connect caches media types more aggressively, and caches all object types for longer times, when there is no explicit expiration time.</p> <ul style="list-style-type: none"> <li>cwoAoHttpxStatsAKCAdvCacheTrans</li> <li>cwoAoHttpxStatsAKCAdvRespBytes</li> <li>cwoAoHttpxStatsAKCAdvCacheTransPercent</li> <li>cwoAoHttpxStatsAKCAdvRespBytesPercent</li> <li>cwoAoHttpxStatsAKCAdvCacheRespTimeSaved</li> <li>cwoAoHttpxStatsAKCAdvAvgCacheRespTimeSaved</li> <li>cwoAoHttpxStatsAKCAdvRespTimeSavedPercent</li> </ul> |
| cwoAoHttpxStatsAKCTotalEntry | <p>Provides summary information about the Akamai Connect cache, from all caching modes.</p> <ul style="list-style-type: none"> <li>cwoAoHttpxStatsAKCTotalCacheTrans</li> <li>cwoAoHttpxStatsAKCTotalRespBytes</li> <li>cwoAoHttpxStatsAKCTotalCacheTransPercent</li> <li>cwoAoHttpxStatsAKCTotalRespBytesPercent</li> <li>cwoAoHttpxStatsAKCTotalCacheRespTimeSaved</li> <li>cwoAoHttpxStatsAKCTotalAvgCacheRespTimeSaved</li> <li>cwoAoHttpxStatsAKCTotalRespTimeSavedPercent</li> </ul>                                                                                                                                  |

## Alarms (CISCO-CONTENT-ENGINE-MIB)

Table 17-3 describes **CISCO-CONTENT-ENGINE-MIB** objects that are used to verify if there are critical, major, or minor alarms raised on the system.

**Table 17-3** Alarms MIB Objects

| MIB Object            | Description                                                              |
|-----------------------|--------------------------------------------------------------------------|
| cceAlarmMinorCount    | The number of alarms currently raised with a severity level of Minor.    |
| cceAlarmMajorCount    | The number of alarms currently raised with a severity level of Major.    |
| cceAlarmCriticalCount | The number of alarms currently raised with a severity level of Critical. |

## AOs (CISCO-WAN-OPTIMIZATION-MIB)

The **CISCO-WAN-OPTIMIZATION-MIB** group displays information about the status and statistics associated with application optimizers.



The Application Optimizers (AOs), also known as Application Accelerators, statistics MIB group displays status information such as configuration or license information for AOs including HTTP, SSL, MAPI, SMB, and ICA.

This section contains the following tables for the **cwoAoStats** MIB objects:



- Table 17-4, “AO Name, Configuration, and License MIB Objects”

- Table 17-5, “AO Operational Status, Startup Time, and Reset Time MIB Objects”
- Table 17-6, “AO Summary Connection Information MIB Objects”
- Table 17-7, “AO Current Connection Information MIB Objects”
- Table 17-8, “AO Load Status and Bandwidth Information MIB Objects”

**Table 17-4 AO Name, Configuration, and License MIB Objects**

| MIB Object             | Description                                                                                                                                                                                                                                                              |
|------------------------|--------------------------------------------------------------------------------------------------------------------------------------------------------------------------------------------------------------------------------------------------------------------------|
| cwoAoStatsName         | The name of the AO, such as HTTP, SSL, MAPI, SMB, NFS, and ICA.                                                                                                                                                                                                          |
| cwoAoStatsIsConfigured | Indicates if the AO is configured or not.<br><br><br><b>Note</b> If the AO is not configured, then the <b>cwoAoStatsOperationalState</b> for this AO is Shutdown.                       |
| cwoAoStatsIsLicensed   | Indicates if the license for the AO is valid or not.<br><br><br><b>Note</b> If the license for the AO is not valid, then the <b>cwoAoStatsOperationalState</b> for this AO is Shutdown. |

**Table 17-5 AO Operational Status, Startup Time, and Reset Time MIB Objects**

|                            |                                                                                                                                                                                                                                                                                                                                                                                                                                                                                     |
|----------------------------|-------------------------------------------------------------------------------------------------------------------------------------------------------------------------------------------------------------------------------------------------------------------------------------------------------------------------------------------------------------------------------------------------------------------------------------------------------------------------------------|
| cwoAoStatsOperationalState | The operational state of the AO: <ul style="list-style-type: none"> <li>• shutdown (1)</li> <li>• initializing (2)</li> <li>• normalRunning (3)</li> <li>• normalDisabled (4)</li> <li>• licenseExpired (5)</li> <li>• cleaningup (6)</li> <li>• error (7)</li> </ul> <br><b>Note</b> If the AO is not configured or if the license for this AO is not valid, the operational state is Shutdown. |
| cwoAoStatsStartUpTime      | The date and time when the AO was started.                                                                                                                                                                                                                                                                                                                                                                                                                                          |
| cwoAoStatsLastResetTime    | The date and time of the last time the statistics of the AO were reset. When the specified AO's statistics are reset, then all statistics counters are also reset.<br><br><br><b>Note</b> When the specified AO is in the Shutdown state, the value of <b>cwoAoStatsStartUpTime</b> and <b>cwoAoStatsLastResetTime</b> is Null.                                                                  |

**cwoAoStats MIB Objects for AO Summary Connection Information****Table 17-6 AO Summary Connection Information MIB Objects**

| MIB Object                   | Description                                                                                                                            |
|------------------------------|----------------------------------------------------------------------------------------------------------------------------------------|
| cwoAoStatsTotalHandledConn   | Total number of connections handled by the AO since it was started or since its statistics were last reset.                            |
| cwoAoStatsTotalOptConn       | Total number of connections optimized by the AO since it was started or since its statistics were last reset.                          |
| cwoAoStatsTotalHandedOffConn | Total number of connections handed off to generic optimization by the AO since it was started or since its statistics were last reset. |
| cwoAoStatsTotalDroppedConn   | Total number of connections dropped by the AO since it was started or since its statistics were last reset.                            |

**Table 17-7 AO Current Connection Information MIB Objects**

| MIB Object                 | Description                                                                                        |
|----------------------------|----------------------------------------------------------------------------------------------------|
| cwoAoStatsActiveOptConn    | The number of active connections that are getting optimized by the AO.                             |
| cwoAoStatsMaxActiveOptConn | The maximum number of active TCP connections the AO can optimize.                                  |
| cwoAoStatsPendingConn      | The number of connections currently pending in the queue of connections to be optimized by the AO. |

**Table 17-8 AO Load Status and Bandwidth Information MIB Objects**

| MIB Object           | Description                                                                        |
|----------------------|------------------------------------------------------------------------------------|
| cwoAoStatsLoadStatus | The load status of the AO.                                                         |
| cwoAoStatsBwOpt      | The percentage bandwidth optimization achieved due to optimization done by the AO. |

**Applications (CISCO-WAN-OPTIMIZATION-MIB)**

The **cwoAppStats** MIB object displays information about application optimization and traffic.

**Table 17-9 Applications Information MIB Objects**

| MIB Object                | Description                                                                                                      |
|---------------------------|------------------------------------------------------------------------------------------------------------------|
| cwoAppStatsAppName        | The name of a particular application that is configured for optimization.                                        |
| cwoAppStatsOriginalBytes  | The total original traffic (uncompressed) in bytes of a particular application that has entered into the system. |
| cwoAppStatsOptimizedBytes | The total optimized traffic, in bytes, of a particular application.                                              |
| cwoAppStatsPTBytes        | The total pass-through traffic, in bytes, of a particular application.                                           |

## AppNav (CISCO-APPNAV-MIB)

The CISCO-APPNAV-MIB group displays information about AppNav when the WAAS device is in AppNav Controller mode.

This section contains the following topics:

- [AppNav Controller MIB Objects](#)
- [AppNav Controller Group MIB Objects](#)
- [AppNav Service Node MIB Objects](#)
- [AppNav Service Node Group MIB Objects](#)
- [AppNav Service Context MIB Objects](#)

### AppNav Controller MIB Objects

An AppNav Controller is a device that intercepts network traffic and, based on a flow policy, distributes that traffic to one more WAAS nodes for optimization. [Table 17-10](#) displays AppNav Controller MIB objects.

**Table 17-10** *AppNav Controller Group MIB Objects*

| MIB Object               | Description                                                                                                                                                                                                                                                                                                                                                                                                                       |
|--------------------------|-----------------------------------------------------------------------------------------------------------------------------------------------------------------------------------------------------------------------------------------------------------------------------------------------------------------------------------------------------------------------------------------------------------------------------------|
| cAppNavACIndex           | An index of the cAppNavACTable. The unique integer value generated for each entry must remain constant at least from one re-initialization of the entity's network management system to the next re-initialization.                                                                                                                                                                                                               |
| cAppNavACIpAddrType      | The address type of the cAppNavACIpAddr object. The cAppNavACEntries are only valid for address types of IPv4 and IPv6.                                                                                                                                                                                                                                                                                                           |
| cAppNavACIpaddr          | The IP address of the AppNav Controller.                                                                                                                                                                                                                                                                                                                                                                                          |
| cAppNavACServContextName | The name of the service context to which the specified AppNav Controller belongs.                                                                                                                                                                                                                                                                                                                                                 |
| cAppNavACACGName         | The name of the AppNav Controller Group to which the specified AppNav Controller belongs.                                                                                                                                                                                                                                                                                                                                         |
| cAppNavACCurrentCMState  | The current cluster membership state of the specified AppNav Controller. <ul style="list-style-type: none"> <li>• Green (1)—Operational with no error conditions</li> <li>• Yellow (2)—Degraded (overloaded, joining cluster, or has other noncritical operational issues)</li> <li>• Red (3)—Critical (one or more processes is in a critical state)</li> <li>• Gray (4)—Disabled</li> <li>• Black (5)—Unknown status</li> </ul> |

### AppNav Controller Group MIB Objects

An AppNav Controller Group is a group of AppNav Controllers that together provide the necessary intelligence for handling asymmetric flows and high availability. [Table 17-11](#) displays AppNav Controller Group MIB objects.

**Table 17-11** *AppNav Controller Group MIB Objects*

| MIB Object                | Description                                                                                                                                                                                                                 |
|---------------------------|-----------------------------------------------------------------------------------------------------------------------------------------------------------------------------------------------------------------------------|
| cAppNavACGIndex           | An index of the <b>AppNavACGTable</b> . The unique integer value generated for each entry must remain constant at least from one re-initialization of the entity's network management system to the next re-initialization. |
| cAppNavACGName            | The name of the AppNav Controller Group.                                                                                                                                                                                    |
| cAppNavACGServContextName | The service context to which the specified AppNav Controller Group belongs.                                                                                                                                                 |

### AppNav Service Node MIB Objects

A WAAS node is also known as a service node. [Table 17-12](#) displays AppNav service node MIB objects.

**Table 17-12** *AppNav Service Node MIB Objects*

| MIB Object               | Description                                                                                                                                                                                                                                                                                                                                                                                                                  |
|--------------------------|------------------------------------------------------------------------------------------------------------------------------------------------------------------------------------------------------------------------------------------------------------------------------------------------------------------------------------------------------------------------------------------------------------------------------|
| cAppNavSNIndex           | An index of the <b>cAppNavSNTable</b> . The unique integer value generated for each entry must remain constant at least from one re-initialization of the entity's network management system to the next re-initialization.                                                                                                                                                                                                  |
| cAppNavSNIpAddrType      | The address type of <b>cacSNIpAddr</b> . The <b>cacSNEntries</b> are valid for address types IPv4 and IPv6 only.                                                                                                                                                                                                                                                                                                             |
| cAppNavSNIpAddr          | The IP address of the specified service node.                                                                                                                                                                                                                                                                                                                                                                                |
| cAppNavSNServContextName | The name of the service context to which the specified service node belongs.                                                                                                                                                                                                                                                                                                                                                 |
| cAppNavSNSNGName         | The name of the service node group to which the specified service node belongs.                                                                                                                                                                                                                                                                                                                                              |
| cAppNavSNCurrentCMState  | The current cluster membership state of the specified service node. <ul style="list-style-type: none"> <li>• Green (1)—Operational with no error conditions</li> <li>• Yellow (2)—Degraded (overloaded, joining cluster, or has other noncritical operational issues)</li> <li>• Red (3)—Critical (one or more processes is in a critical state)</li> <li>• Gray (4)—Disabled</li> <li>• Black (5)—Unknown status</li> </ul> |

### AppNav Service Node Group MIB Objects

A WAAS node is also known as a service node. [Table 17-13](#) displays AppNav service node MIB objects.

**Table 17-13** *AppNav Service Node MIB Objects*

| <b>MIB Object</b>        | <b>Description</b>                                                                                                                                                                                                                                                                                                                                                                                                           |
|--------------------------|------------------------------------------------------------------------------------------------------------------------------------------------------------------------------------------------------------------------------------------------------------------------------------------------------------------------------------------------------------------------------------------------------------------------------|
| cAppNavSNIndex           | An index of the <b>cAppNavSNTable</b> . The unique integer value generated for each entry must remain constant at least from one re-initialization of the entity's network management system to the next re-initialization.                                                                                                                                                                                                  |
| cAppNavSNIpAddrType      | The address type of <b>cacSNIpAddr</b> . The <b>cacSNEntries</b> are valid for address types IPv4 and IPv6 only.                                                                                                                                                                                                                                                                                                             |
| cAppNavSNIpAddr          | The IP address of the specified service node.                                                                                                                                                                                                                                                                                                                                                                                |
| cAppNavSNServContextName | The name of the service context to which the specified service node belongs.                                                                                                                                                                                                                                                                                                                                                 |
| cAppNavSNSNGName         | The name of the service node group to which the specified service node belongs.                                                                                                                                                                                                                                                                                                                                              |
| cAppNavSNCurrentCMState  | The current cluster membership state of the specified service node. <ul style="list-style-type: none"> <li>• Green (1)—Operational with no error conditions</li> <li>• Yellow (2)—Degraded (overloaded, joining cluster, or has other noncritical operational issues)</li> <li>• Red (3)—Critical (one or more processes is in a critical state)</li> <li>• Gray (4)—Disabled</li> <li>• Black (5)—Unknown status</li> </ul> |

### AppNav Service Node Group MIB Objects

A Service Node Group is also known as a WAAS Node Group. [Table 17-14](#) displays AppNav Service Node Group MIB objects.

**Table 17-14** *AppNav Service Node Group Information MIB Objects*

| <b>MIB Object</b>         | <b>Description</b>                                                                                                                                                                                                           |
|---------------------------|------------------------------------------------------------------------------------------------------------------------------------------------------------------------------------------------------------------------------|
| cAppNavSNGIndex           | An index of the <b>cAppNavSNGTable</b> . The unique integer value generated for each entry must remain constant at least from one re-initialization of the entity's network management system to the next re-initialization. |
| cAppNavSNGName            | The name of the Service Node Group.                                                                                                                                                                                          |
| cAppNavSNGServContextName | The service context to which the specified Service Node Group belongs.                                                                                                                                                       |

### AppNav Service Context MIB Objects

A service context is used to tie the AppNav Controller group, service node group, and AppNav policy map together. [Table 17-15](#) displays the AppNav Service Context MIB objects.



**Table 17-15** *AppNav Service Context Information MIB Objects*

| MIB Object                    | Description                                                                                                                                                                                                                             |
|-------------------------------|-----------------------------------------------------------------------------------------------------------------------------------------------------------------------------------------------------------------------------------------|
| cAppNavServContextIndex       | An index of the <b>cAppNavServiceContextTable</b> . The unique integer value generated for each entry must remain constant at least from one re-initialization of the entity's network management system to the next re-initialization. |
| cAppNavServContextName        | The name of the service context.                                                                                                                                                                                                        |
| cAppNavServContextCurrOpState | The current operational state of the service context.                                                                                                                                                                                   |
| cAppNavServContextLastOpState | The last operational state of the service context.                                                                                                                                                                                      |
| cAppNavServContextIRState     | The Interception Readiness (IR) state of the service context.                                                                                                                                                                           |
| cAppNavServContextJoinState   | The Join state of the service context.                                                                                                                                                                                                  |

## Class Maps (CISCO-WAN-OPTIMIZATION-MIB)

AppNav class maps classify traffic according to one or more match conditions, such as peer device ID, or a mix of one peer device ID and the source IP, or destination IP, or destination port. [Table 17-16](#) shows class map information MIB objects.

**Table 17-16** *Class Map Information MIB Objects*

| MIB Object               | Description                                                                                                                                                                                 |
|--------------------------|---------------------------------------------------------------------------------------------------------------------------------------------------------------------------------------------|
| cwoCmapStatsType         | The class map type, such as HTTP, MAPI, NFS, or a custom class map.                                                                                                                         |
| cwoCmapStatsName         | The name of the class map.                                                                                                                                                                  |
| cwoCmapStatsDescr        | The descriptive information of the class map configured on the WAN optimization system. If the description is not configured for a given class map, then this string will be a NULL string. |
| cwoCmapStatsTotalConns   | The total number of connections processed by the class map.                                                                                                                                 |
| cwoCmapStatsTotalBytes   | The total number of bytes processed by the class map.                                                                                                                                       |
| cwoCmapStatsTotalPTConns | The total connections made as pass-through, due to some reason by the class map.                                                                                                            |
| cwoCmapStatsTotalPTBytes | The total number of bytes made pass-through by the class map.                                                                                                                               |

## Configuration (CISCO-CONFIG-MAN-MIB)

The CISCO-CONFIG-MAN-MIB group represents a model of configuration data that exists in various locations:

- Running—In use by the running system
- Terminal—Saved to whatever hardware is attached as the terminal
- Local—Saved locally in NVRAM or in flash memory
- Remote—Saved to a server on the network



### Note

The CISCO-CONFIG-MAN-MIB group includes only operations that are specifically related to configuration, although some of the system functions can be used for general file storage and transfer.

## CPU and Memory (CISCO-PROCESS-MIB)

The CISCO-PROCESS-MIB group displays memory and CPU usage on the device and also describes active system processes.

CPU utilization presents a status of how busy the system is. The numbers are a ratio of the current idle time over the longest idle time. (This information should be used as an estimate only.)

**Table 17-17 CPU and Memory Information MIB Objects**

| MIB Object         | Description                                                                       |
|--------------------|-----------------------------------------------------------------------------------|
| cpmCPUTotal1minRev | The overall CPU percentage showing how busy the system was in the last 1 minute.  |
| cpmCPUTotal5minRev | The overall CPU percentage showing how busy the system was in the last 5 minutes. |

## Devices (CISCO-CDP-MIB and CISCO-ENTITY-ASSET-MIB)

This section describes two MIB groups:

- [CISCO-CDP-MIB Group](#)
- [CISCO-ENTITY-ASSET-MIB Group](#)

### CISCO-CDP-MIB Group

The CISC-CDP-MIB group displays the **ifIndex** value of the local interface.

For example:

- For 802.3 repeaters on which the repeater ports do not have ifIndex values assigned, this value is a unique value for the port and is greater than any ifIndex value supported by the repeater.
- In this example, the specific port is indicated by the corresponding values of **cdpInterfaceGroup** and **cdpInterfacePort**, where these values correspond to the group number and the port number values of RFC 1516.

### CISCO-ENTITY-ASSET-MIB Group

The CISCO-ENTITY-ASSET-MIB group provides information about items in the **entPhysicalTable** MIB object, including part number, serial number, hardware version, firmware ID and software ID. A full description of these is provided in RFC 2037.

Note the following about information listed in **entPhysicalTable**:

- Displayed information includes the orderable part number, serial number, hardware revision, manufacturing assembly number and revision, firmware ID and revision (if any), and software ID and revision (if any) of relevant entities listed in **entPhysicalTable**. Entities that have none of this data available are not listed in this MIB.
- The **entPhysicalTable** is sparsely populated. Therefore, some variables may not exist for a particular entity at a particular time.

For example, a row that represents a powered-off module may have no values for software ID (**ceAssetSoftwareID**) and revision (**ceAssetSoftwareRevision**). Similarly, a power supply would probably never have firmware or software information listed in the table.

- The data may have other items encoded in it.

For example, a manufacturing date in the serial number, consider all data items to be a single unit. Do not decompose the items or parse them. Use only string equal and unequal operations on them.

## DRE Cache (CISCO-WAN-OPTIMIZATION-MIB)

Table 17-18 displays optimization DRE cache statistics MIB objects, which provide information such as the portion of disk space allocated for DRE cache or the percentage of DRE disk space currently being used.

**Table 17-18 DRE Cache Statistics MIB Objects**

| MIB Object                            | Description                                                                                                                                                                                                                                                                                                                                       |
|---------------------------------------|---------------------------------------------------------------------------------------------------------------------------------------------------------------------------------------------------------------------------------------------------------------------------------------------------------------------------------------------------|
| cwoDreCacheStatsStatus                | The status of the portion of the disk allocated for DRE cache: Initializing, Usable, or Failed.                                                                                                                                                                                                                                                   |
| cwoDreCacheStatsAge                   | The age of the oldest data present in the DRE cache. When new data is written to the DRE cache portion of the disk, it replaces the oldest data in the DRE cache.                                                                                                                                                                                 |
| cwoDreCacheStatsTotal                 | The portion of disk space allocated for DRE cache, in MB.<br><br>For example, if the total cache disk space is 708 MB, and the portion allocated for DRE cache is 10%, then the value of <b>cwoDreCacheStatsTotal</b> , as shown below in the sample output, is 70800 MB.                                                                         |
| cwoDreCacheStatsUsed                  | The percentage of DRE disk space currently being used.<br><br>For example, if the disk space allocated for DRE is 70800 MB, and the value of <b>cwoDreCacheStatsUsed</b> is 85%, as shown below in the sample output, this indicates that 60,180 MB of the DRE cache disk space is being used, and 10,620 MB of the DRE cache disk space is free. |
| cwoDreCacheStatsDataUnitUsage         | The DRE cache disk space currently being used, by data unit.                                                                                                                                                                                                                                                                                      |
| cwoDreCacheStatsReplacedOneHrDataUnit | The amount of data units replaced in the DRE cache in the last hour. Data is replaced on a First In/First Out (FIFO) order, and is stored in the DRE cache data block.                                                                                                                                                                            |
| cwoDreCacheStatsDataUnitAge           | The age of the oldest data unit in the data block. When new data is written to the data block when the data block is full, the oldest data unit is removed.                                                                                                                                                                                       |
| cwoDreCacheStatsSigblockUsage         | The DRE disk space currently used by the signature block.                                                                                                                                                                                                                                                                                         |
| cwoDreCacheStatsReplacedOneHrSigblock | The amount of cache replaced within the last hour by the signature block.                                                                                                                                                                                                                                                                         |
| cwoDreCacheStatsSigblockAge           | The time that the DRE Sigblock has been in the cache in days (d), hours (h), minutes (m), and seconds (s). For example, “1d1h” means 1 day, 1 hour.                                                                                                                                                                                               |

## DRE Performance (CISCO-WAN-OPTIMIZATION-MIB)

Table 17-19 displays DRE performance MIB objects, which provide information such as DRE compression ratio during decoding or the decoding average message size.

**Table 17-19 DRE Performance Statistics MIB Objects**

| MIB Object                              | Description                                                    |
|-----------------------------------------|----------------------------------------------------------------|
| cwoDrePerfStatsEncodeCompressionRatio   | The DRE compression ratio during encoding.                     |
| cwoDrePerfStatsEncodeCompressionLatency | The Encoding average latency introduced to compress a message. |
| cwoDrePerfStatsEncodeAvgMsgSize         | The Encoding average message size.                             |
| cwoDrePerfStatsDecodeCompressionRatio   | The DRE compression ratio during decoding.                     |
| cwoDrePerfStatsDecodeCompressionLatency | The Decoding average latency introduced to compress a message. |
| cwoDrePerfStatsDecodeAvgMsgSize         | The Decoding average message size.                             |

## HTTP (CISCO-WAN-OPTIMIZATION-MIB)

Table 17-20 shows the HTTP AO information MIB objects, which provide information such as the percentage estimated time saved due to optimizations done by HTTP AO since it was started or the total number of SharePoint Optimized HTTP sessions.

**Table 17-20 HTTP AO Information MIB Objects**

| MIB Object                     | Description                                                                                                                                                                                                                                                         |
|--------------------------------|---------------------------------------------------------------------------------------------------------------------------------------------------------------------------------------------------------------------------------------------------------------------|
| cwoAoHttpxStatsTotalSavedTime  | The total time saved due to optimizations done by HTTP AO since it was started.                                                                                                                                                                                     |
| cwoAoHttpxStatsTotalRTT        | The total Round Trip Time (RTT) for all the connections going through HTTP AO since it was started.                                                                                                                                                                 |
| cwoAoHttpxStatsTotalMDCMTime   | The Meta Data Cache Misses (MDCM) for HTTP AO since it was started.                                                                                                                                                                                                 |
| cwoAoHttpxStatsEstSavedTime    | The percentage estimated time saved due to optimizations done by HTTP AO since it was started.                                                                                                                                                                      |
| cwoAoHttpxStatsTotalSPSessions | The total number of SharePoint Optimized HTTP sessions.<br>This counter is incremented for every session on which SharePoint optimization can be performed. An HTTP session is tagged as a SharePoint Session based on the information present in the HTTP request. |

| MIB Object                       | Description                                                                                                                                                                                                                                                                                                                                                                                                                                                                                                                                                                        |
|----------------------------------|------------------------------------------------------------------------------------------------------------------------------------------------------------------------------------------------------------------------------------------------------------------------------------------------------------------------------------------------------------------------------------------------------------------------------------------------------------------------------------------------------------------------------------------------------------------------------------|
| cwoAoHttpxStatsTotalSPPFSessions | <p>The total number of SharePoint Pre-fetch optimized HTTP sessions.</p> <ul style="list-style-type: none"> <li>This counter is incremented for every session on which SharePoint pre-fetch optimization can be performed.</li> <li>An HTTP session is tagged as a SharePoint pre-fetch Session based on the information present in the HTTP request.</li> <li>A pre-fetch operation is one where the edge WAAS device fetches the next set of data (which it anticipates the client will request later) from the server based on the current HTTP Request information.</li> </ul> |
| cwoAoHttpxStatsTotalSPPFObjects  | <p>The total number of pre-fetched objects served locally for SharePoint pre-fetch sessions.</p> <ul style="list-style-type: none"> <li>The edge WAAS device maintains a local cache where the pre-fetched responses are saved.</li> <li>This object is incremented whenever the SharePoint client request is served from the pre-fetch cache.</li> </ul>                                                                                                                                                                                                                          |
| cwoAoHttpxStatsTotalSPRTTSaved   | <p>The total Round Trip Time (RTT) saved due to SharePoint pre-fetch optimizations since SharePoint pre-fetch optimization was started.</p>                                                                                                                                                                                                                                                                                                                                                                                                                                        |
| cwoAoHttpxStatsTotalSPPFMissTime | <p>The total time for SharePoint pre-fetch Cache Misses since SharePoint pre-fetch optimization was started.</p>                                                                                                                                                                                                                                                                                                                                                                                                                                                                   |

**Note**

Discontinuities in the value of these HTTP counters can occur at re-initialization of the HTTP AO. The last discontinuity time is indicated by the value of **cwoAoStatsLastResetTime** for the HTTP AO.

## Interfaces (IF-MIB)

The IF-MIB group supports querying for interface-related statistics including 64-bit interface counters. These counters include received and sent octets, unicast, multicast, and broadcast packets on the device interfaces. All the objects from ifXEntry are supported except for ifCounterDiscontinuityTime. This MIB is documented in RFC 2233.

Loopback interface interface information are not reported.

A transmission error or discard can point to Layer 1 or Layer 2 problems, such as a bad cable or a speed/duplex mismatch on a connected switch or router.

This section contains the following types of MIB objects for the IF-MIB group:

- [Interface Description MIB Object](#)
- [Interface Status MIB Objects](#)
- [Interface Discards MIB Objects](#)
- [Interface Errors MIB Objects](#)

## Interface Description MIB Object

The **ifDescr** MIB object displays information about the interface, including the name of the manufacturer, the product name, and the version of the hardware or software interface.

## Interface Status MIB Objects

This section describes two interface status MIB objects:

- **ifAdminStatus**—Displays the desired (specified) status of the interface:
  - up (1)—The interface is up and ready to transmit and receive network traffic.
  - down (2)—The interface is down.
  - testing (3)—In the Testing state, no operational packets can be passed.



---

**Note** At system startup, all interfaces start with **ifAdminStatus** down. After either management action or configuration information, **ifAdminStatus** is changed to either up or testing, or remains down.

---

- **ifOperStatus**—Displays the current operational status of the interface:
  - up (1)—The interface is up and ready to transmit and receive network traffic.
  - down (2)—The interface is down.
  - testing(3)—In the Testing state, no operational packets can be passed.
  - unknown(4)—The status of the interface cannot be determined.
  - dormant(5)—The interface is waiting for an external action.
  - notPresent(6)—The interface has a missing component; usually a missing hardware component.
  - lowerLayerDown(7)—The interface is down due to a lower-layer interface.



---

**Note** If **ifAdminStatus** is down, then **ifOperStatus** should also be down. If **ifAdminStatus** is up, then **ifOperStatus** should also be up.

---

## Interface Discards MIB Objects

**Table 17-21** *Interface Discards MIB Objects*

| MIB Object    | Description                                                                                                                                                                                                                                                                                                                      |
|---------------|----------------------------------------------------------------------------------------------------------------------------------------------------------------------------------------------------------------------------------------------------------------------------------------------------------------------------------|
| ifInDiscards  | Displays the number of inbound packets selected to be discarded, even though no errors have been detected to prevent their being deliverable to a higher-layer protocol. A possible reason for discarding such a packet is to free up buffer space.                                                                              |
| ifOutDiscards | The number of outbound packets selected to be discarded, even though no errors had been detected to prevent them from being transmitted. A possible reason for discarding such a packet is to free up buffer space.<br><br>The <b>ifInDiscards</b> MIB object is usually a subset of the <b>locIfInputQueueDrops</b> MIB object. |

**Note**

Discontinuities in the value of **ifInDiscards** or of **ifOutDiscards** can occur at re-initialization of the management system and at other times, as indicated by the value **ifCounterDiscontinuityTime**.

## Interface Errors MIB Objects

**Table 17-22** *Interface Errors MIB Objects*

| MIB Object  | Description                                                                                                                                                                                                                                                                                                                                 |
|-------------|---------------------------------------------------------------------------------------------------------------------------------------------------------------------------------------------------------------------------------------------------------------------------------------------------------------------------------------------|
| ifInErrors  | For packet-oriented interfaces, the number of inbound packets that contained errors preventing them from being deliverable to a higher-layer protocol. For character-oriented or fixed-length interfaces, the number of inbound transmission units that contained errors preventing them from being deliverable to a higher-layer protocol. |
| ifOutErrors | For packet-oriented interfaces, the number of outbound packets that could not be transmitted because of errors. For character-oriented or fixed-length interfaces, the number of outbound transmission units that could not be transmitted because of errors.                                                                               |

**Note**

Discontinuities in the value of **ifInErrors** or of **ifOutErrors** can occur at re-initialization of the management system and at other times, as indicated by the value **ifCounterDiscontinuityTime**.

## IP Routing (IP-MIB, IP-FORWARD-MIB, MIB-II)

This section contains the following MIB groups:

- [IP-MIB Group](#)
- [IP-FORWARD-MIB Group](#)
- [MIB-II Group](#)

### IP-MIB Group

The IP-MIB group manages IP and ICMP implementations, excluding their management of IP routes.

### IP-FORWARD-MIB Group

Displays Classless Inter-Domain Routing (CIDR) multi-path IP Routes.

### MIB-II Group

The MIB-II group is the Internet Standard MIB, and is used with network management protocols in TCP/IP-based internets. The MIB-II is documented in RFC 1213, and is found in the RFC1213-MIB file in the v1 directory on the download site (other MIBs are in the v2 directory).

**Note**

The following objects from this MIB are *not* supported:

- ifInUnknownProtos
- ifOutNUcastPkts
- ipRouteAge
- TcpConnEntry group

- egpInMsgs
- egpInErrors
- egpOutMsgs
- egpOutErrors
- EgpNeighEntry group
- egpAs
- atTable
- ipRouteTable

## MAPI (CISCO-WAN-OPTIMIZATION-MIB)

Table 17-23 displays the Message Application Programming Interface (MAPI) AO MIB objects.



### Note

For these MIB objects, discontinuities in the value of the counter can occur at re-initialization of the MAPI AO. The last discontinuity time is indicated by the value of **cwoAoStatsLastResetTime** for the MAPI AO.

**Table 17-23** MAPI AO MIB Objects

| MIB Object                      | Description                                                                                                          |
|---------------------------------|----------------------------------------------------------------------------------------------------------------------|
| cwoAoMapixStatsUnEncrALRT       | The Average Local Response Time (ALRT) for unencrypted connections of MAPI AO since it was started.                  |
| cwoAoMapixStatsUnEncrARRT       | The Average Remote Response Time (ARRT) for unencrypted connections of MAPI AO since it was started.                 |
| cwoAoMapixStatsTotalUnEncrLRs   | The total requests served locally for unencrypted connections by MAPI AO since it was started.                       |
| cwoAoMapixStatsTotalUnEncrRRs   | The total Remote Requests (RR) served by remote servers for unencrypted connections of MAPI AO since it was started. |
| cwoAoMapixStatsUnEncrAvgRedTime | The average time reduced for unencrypted connections due to optimizations done by MAPI AO since it was started.      |
| cwoAoMapixStatsEncrALRT         | The Average Local Response Time (ALRT) for encrypted connections of MAPI AO since it was started.                    |
| cwoAoMapixStatsEncrARRT         | The Average Remote Response Time (ARRT) for encrypted connections of MAPI AO since it was started.                   |
| cwoAoMapixStatsTotalEncrLRs     | The total requests served locally for encrypted connections by MAPI AO since it was started.                         |
| cwoAoMapixStatsTotalEncrRRs     | The total Remote Requests (RR) served by remote servers for encrypted connections by MAPI AO since it was started.   |
| cwoAoMapixStatsEncrAvgRedTime   | The average time reduced for encrypted connections due to optimizations done by MAPI AO since it was started.        |



## NFS (CISCO-WAN-OPTIMIZATION-MIB)

Table 17-24 displays the Network File System (NFS) application accelerator MIB objects.



### Note

For these MIB objects, discontinuities in the value of the counter can occur at re-initialization of the NFS AO. The last discontinuity time is indicated by the value of **cwoAoStatsLastResetTime** for the NFS AO.

**Table 17-24 NFS MIB Objects**

| MIB Object                 | Description                                                                                   |
|----------------------------|-----------------------------------------------------------------------------------------------|
| cwoAoNfsxStatsALRT         | Indicates the Average Local Response Time (ALRT) for the NFS AO since it was started.         |
| cwoAoNfsxStatsARRT         | Indicates the Average Remote Response Time (ARRT) for the NFS AO since it was started.        |
| cwoAoNfsxStatsTotalLRs     | The total requests served locally by the NFS AO since it was started.                         |
| cwoAoNfsxStatsTotalRRs     | The total Remote Requests (RR) served by remote servers for the NFS AO since it was started.  |
| cwoAoNfsxStatsEstTimeSaved | The percentage estimated time saved due to optimizations done by NFS AO since it was started. |

## Network Management (EVENT-MIB, HOST-RESOURCES-MIB)

This section contains the following MIB groups:

- [EVENT-MIB Group](#)
- [HOST-RESOURCES-MIB Group](#)

### EVENT-MIB Group

The EVENT-MIB group defines the event triggers and actions for network management purposes. This MIB is described in RFC 2981.

### HOST-RESOURCES-MIB Group

This MIB manages host systems. The term “host” implies any computer that communicates with other similar computers connected to the Internet.

The HOST-RESOURCES-MIB provides attributes that are common to all Internet hosts, for example, personal computers and systems that run variants of UNIX. It does not apply to devices whose primary function is communications services (terminal servers, routers, bridges, monitoring equipment).



### Note

The following objects from this MIB are *not* supported:

- HrPrinterEntry
- hrSWOSIndex
- hrSWInstalledGroup

## Policy Maps (CISCO-WAN-OPTIMIZATION-MIB)

Policy maps associate policy actions with class maps. [Table 17-25](#) shows the policy maps MIB objects, which display information such as the type of policy map or the total number of connections processed by the policy map since it has been active.

**Table 17-25 Policy Maps MIB Objects**

| MIB Object               | Description                                                                                                                                                                          |
|--------------------------|--------------------------------------------------------------------------------------------------------------------------------------------------------------------------------------|
| cwoPmapStatsType         | The type of policy map.                                                                                                                                                              |
| cwoPmapStatsName         | The name of the policy map.                                                                                                                                                          |
| cwoPmapStatsDescr        | The description of the policy map configured on the WAN optimization system. If a description is not configured for a particular policy map, this string will contain a NULL string. |
| cwoPmapStatsTotalConns   | The total number of connections processed by the policy map since it has been active.                                                                                                |
| cwoPmapStatsTotalBytes   | The total bytes processed by the policy map since it has been active.                                                                                                                |
| cwoPmapStatsTotalPTConns | The total connections made as pass-through connections, due to some reason by the policy map, since it has been active.                                                              |
| cwoPmapStatsTotalPTBytes | The total bytes made as pass-through, due to some reason by the policy map, since it has been active.                                                                                |

## SMB (CISCO-WAN-OPTIMIZATION-MIB)

The CISCO-WAN-OPTIMIZATION-MIB group displays information about the status and statistics associated with optimization and application accelerators.



### Note

For these MIB objects, discontinuities in the value of the counter can occur at re-initialization of the SMB AO. The last discontinuity time is indicated by the value of **cwoAoStatsLastResetTime** for the SMB AO.

This section describes the **cwoAoSmbxStats** MIB objects, and contains the following topics:

- [About SMB Statistics MIB Objects](#)
- [cwoAoSmbxStats MIB Objects for Cache Information](#)
- [cwoAoSmbxStats MIB Objects for Client and Server Information](#)
- [cwoAoSmbxStats MIB Objects for LAN and WAN Information](#)
- [cwoAoSmbxStats MIB Objects for RTT, Response Time, and File Information](#)
- [cwoAoSmbxStats MIB Objects for SMB Requests Information](#)

### About SMB Statistics MIB Objects

The Server Message Block (SMB) application accelerator (AO) transparently accelerates traffic and supports repositioning of files. It relies on automatic discovery. You can fine-tune this accelerator for specific traffic needs.

## cwoAoSmbxStats MIB Objects for Cache Information

Table 17-26 SMB AO Cache MIB Objects

| MIB Object                        | Description                                                                                                                                                                                       |
|-----------------------------------|---------------------------------------------------------------------------------------------------------------------------------------------------------------------------------------------------|
| cwoAoSmbxStatsBytesReadCache      | The total number of bytes read from the SMB AO cache (Read-ahead and Metadata cache) since it was started.                                                                                        |
| cwoAoSmbxStatsBytesWriteCache     | The total number of bytes written to SMB AO cache (Read-ahead and Metadata) since it was started.                                                                                                 |
| cwoAoSmbxStatsMDCacheHitCount     | The SMB AO Metadata cache hit count since SMB AO was started.                                                                                                                                     |
| cwoAoSmbxStatsMDCacheHitRate      | The SMB AO Metadata cache hit rate since it was started.                                                                                                                                          |
| cwoAoSmbxStatsMaxRACacheSize      | The maximum disk space that can be allocated for Read Ahead data in the SMB AO cache.                                                                                                             |
| cwoAoSmbxStatsMaxMDCacheSize      | The maximum disk space that can be allocated for Metadata in the SMB AO cache                                                                                                                     |
| cwoAoSmbxStatsRAEvictedAge        | The amount of time spent in the SMB AO Read Ahead cache by the resource that was last evicted since last update.                                                                                  |
|                                   |  <p><b>Note</b> If this amount is too short or too long, we recommend that you modify the size of the cache.</p> |
| cwoAoSmbxStatsTotalFilesInRACache | The total number of files in the SMB AO Read Ahead cache.                                                                                                                                         |

## cwoAoSmbxStats MIB Objects for Client and Server Information

Table 17-27 SMB AO Client and Server MIB Objects

| MIB Object                     | Description                                                                       |
|--------------------------------|-----------------------------------------------------------------------------------|
| cwoAoSmbxStatsBytesReadServer  | The total number of bytes read from file servers by SMB AO since it was started.  |
| cwoAoSmbxStatsBytesWriteServer | The total number of bytes written to file servers by SMB AO since it was started. |
| cwoAoSmbxStatsBytesReadClient  | The total number of bytes read by SMB AO clients since it was started.            |
| cwoAoSmbxStatsBytesWriteClient | The total number of bytes written by SMB AO clients since it was started.         |

## cwoAoSmbxStats MIB Objects for LAN and WAN Information

Table 17-28 SMB AO LAN and WAN MIB Objects

| MIB Object                     | Description                                                                                                                                                                                                                                                                                                |
|--------------------------------|------------------------------------------------------------------------------------------------------------------------------------------------------------------------------------------------------------------------------------------------------------------------------------------------------------|
| cwoAoSmbxStatsRdL4SignWANBytes | The total number of Layer 4 (L4) optimized signed bytes read from WAN by SMB AO since the SMB AO was started. L4 optimization includes TFO, DRE and LZ optimizations.                                                                                                                                      |
| cwoAoSmbxStatsWrL4SignWANBytes | The total number of Layer 4 (L4) optimized signed bytes written to WAN by SMB AO since SMB AO was started. L4 optimization includes TFO, DRE and LZ optimizations.                                                                                                                                         |
| cwoAoSmbxStatsRdSignLANBytes   | The total number of signed bytes read from LAN by SMB AO since the SMB AO was started.                                                                                                                                                                                                                     |
| cwoAoSmbxStatsWrSignLANBytes   | The total number of original signed bytes written to LAN by SMB AO since SMB AO was started.                                                                                                                                                                                                               |
|                                |  <p><b>Note</b> Discontinuities in the values of these counters can occur at re-initialization of the SMB AO. The last discontinuity time is indicated by the value of <b>cwoAoStatsLastResetTime</b> for the SMB AO.</p> |

## cwoAoSmbxStats MIB Objects for RTT, Response Time, and File Information

Table 17-29 SMB RTT, Response Time, and File Information MIB Objects

| MIB Object                        | Description                                                                     |
|-----------------------------------|---------------------------------------------------------------------------------|
| cwoAoSmbxStatsRTT                 | The total round trip time (RTT) for all SMB connections since it was started.   |
| cwoAoSmbxStatsTotalRespTimeSaving | The total response time saved due to SMB AO optimizations since it was started. |
| cwoAoSmbxStatsOpenFiles           | The number of files currently opened by the SMB AO.                             |

## cwoAoSmbxStats MIB Objects for SMB Requests Information

Table 17-30 SMB Requests MIB Objects

| MIB Object                    | Description                                                                                   |
|-------------------------------|-----------------------------------------------------------------------------------------------|
| cwoAoSmbxStatsProcessedReqs   | The total number of requests processed by the SMB AO since it was started.                    |
| cwoAoSmbxStatsActiveReqs      | The total number of active requests getting processed by the SMB AO.                          |
| cwoAoSmbxStatsTotalRemoteReqs | The total number of SMB requests sent to the remote file server since the SMB AO was started. |

| MIB Object                   | Description                                                                                           |
|------------------------------|-------------------------------------------------------------------------------------------------------|
| cwoAoSmbxStatsTotalLocalReqs | The total number of SMB requests served locally by the SMB AO since it was started.                   |
| cwoAoSmbxStatsRemoteAvgTime  | The average duration of time taken by the SMB AO to process all remote requests since it was started. |
| cwoAoSmbxStatsLocalAvgTime   | The average duration of time taken by the SMB AO to process all local requests since it was started.  |

## SNMP (ENTITY, ISNMP, and SNMP MIB Groups)

This section describes the following SNMP MIB groups:

- **ENTITY-MIB**—Represents multiple logical entities supported by a single SNMP agent. This MIB is documented in RFC 2737. The following objects are supported:
  - `entityPhysicalGroup`
  - `entityLogicalGroup`
  - `entConfigChange`
- **SNMP-FRAMEWORK-MIB**—Facilitates remote configuration and administration of the SNMP entity. This MIB is documented in RFC 2571.
- **SNMP-NOTIFICATION-MIB**—Contains objects for the remote configuration of the parameters used by an SNMP entity for the generation of notifications. This MIB is documented in RFC 3413.
- **SNMP-TARGET-MIB**—Provides information about specifying targets of management operations for notification filtering and for proxy forwarding. This MIB is documented in RFC 3413.
- **SNMP-USM-MIB**—Provides information on the User-based Security Model.
- **SNMP-VACM-MIB**—Provides information on the View-based Access Control Model.
- **SNMPv2-MIB**—For this MIB group, WAAS supports the following MIB objects:
  - **coldStart**—Signifies that the SNMPv2 entity, acting in an agent role, is reinitializing itself and that its configuration may have been altered.
  - **linkUp**—The link up trap/notification.
  - **linkDown**—The link down trap/notification.
  - **authenticationFailure**—Signifies that the SNMPv2 entity, acting in an agent role, has received a protocol message that is not properly authenticated. While all implementations of the SNMPv2 must be capable of generating this trap, the `snmpEnableAuthenTraps` object indicates whether this trap will be generated.

This MIB is documented in RFC 1907.

## TFO (CISCO-WAN-OPTIMIZATION-MIB)

The CISCO-WAN-OPTIMIZATION-MIB group displays information about the status and statistics associated with optimization and application accelerators.

This section describes the `cwoTfoStats` MIB objects, and contains the following topics:

- [About TFO Statistics MIB Objects](#)
- [cwoTfoStats MIB Object for TFO Load Status](#)

- [cwoTfoStats MIB Objects for TFO Summary Connection Information](#)
- [cwoTfoStats MIB Objects for TFO Current Connection Information](#)

### About TFO Statistics MIB Objects

WAAS uses a variety of Transport Flow Optimization (TFO) features to optimize TCP traffic intercepted by the WAAS devices. TFO protects communicating clients and servers from negative WAN conditions, such as bandwidth constraints, packet loss, congestion, and retransmission.

### cwoTfoStats MIB Object for TFO Load Status

**Table 17-31** TFO Load Status MIB Object

| MIB Object                       | Description                                                                                                                                                                                                                                                                                                                                                                                                                                                                                                                                                                                                                                                                                                                                                                             |
|----------------------------------|-----------------------------------------------------------------------------------------------------------------------------------------------------------------------------------------------------------------------------------------------------------------------------------------------------------------------------------------------------------------------------------------------------------------------------------------------------------------------------------------------------------------------------------------------------------------------------------------------------------------------------------------------------------------------------------------------------------------------------------------------------------------------------------------|
| cwoTfoStatsLoadStatus            | <p>Displays the current TFO load status:</p> <ul style="list-style-type: none"> <li>• Unknown (1)—TFO is in an unknown state, not active or disabled.</li> <li>• Green (2)—TFO is operating normally, within acceptable load limits.</li> <li>• Yellow (3)—TFO is overloaded, and new connections received may not be optimized.</li> <li>• Red (4)—TFO is not working properly, and both existing and new connections may not be optimized.</li> </ul> <p> <b>Note</b> If <b>cwoTfoStatsLoadStatus</b> shows Unknown (1), Yellow (3) or Red (4), then the TFO is either overloaded or has some other error condition, and no optimization can occur at any other level, such as DRE, LZ, or AO.</p> |
| cwoTfoStatsTotalOptConn          | The total number of connections optimized by the specified AO since it was started or since its statistics were last reset.                                                                                                                                                                                                                                                                                                                                                                                                                                                                                                                                                                                                                                                             |
| cwoTfoStatsTotalNormalClosedConn | The total number of optimized TCP connections that were closed normally since TFO was started, or since its statistics were last reset.                                                                                                                                                                                                                                                                                                                                                                                                                                                                                                                                                                                                                                                 |
| cwoTfoStatsResetConn             | The total number of optimized TCP connections that have been reset since TFO was started or since its statistics were last reset.                                                                                                                                                                                                                                                                                                                                                                                                                                                                                                                                                                                                                                                       |

## cwoTfoStats MIB Objects for TFO Summary Connection Information

Table 17-32 TFO Summary Connection MIB Objects

| MIB Object                       | Description                                                                                                                                                                                                                                                                                                                                                                                                                                                                                                                                                                                                                                                                                                                                                                   |
|----------------------------------|-------------------------------------------------------------------------------------------------------------------------------------------------------------------------------------------------------------------------------------------------------------------------------------------------------------------------------------------------------------------------------------------------------------------------------------------------------------------------------------------------------------------------------------------------------------------------------------------------------------------------------------------------------------------------------------------------------------------------------------------------------------------------------|
| cwoTfoStatsLoadStatus            | <p>Displays the current TFO load status:</p> <ul style="list-style-type: none"> <li>Unknown (1)—TFO is in an unknown state, not active or disabled.</li> <li>Green (2)—TFO is operating normally, within acceptable load limits.</li> <li>Yellow (3)—TFO is overloaded, and new connections received may not be optimized.</li> <li>Red (4)—TFO is not working properly, and both existing and new connections may not be optimized.</li> </ul> <p> <b>Note</b> If <b>cwoTfoStatsLoadStatus</b> shows Unknown (1), Yellow (3) or Red (4), then the TFO is either overloaded or has some other error condition, and no optimization can occur at any other level, such as DRE, LZ, or AO.</p> |
| cwoTfoStatsTotalOptConn          | The total number of connections optimized by the specified AO since it was started or since its statistics were last reset.                                                                                                                                                                                                                                                                                                                                                                                                                                                                                                                                                                                                                                                   |
| cwoTfoStatsTotalNormalClosedConn | The total number of optimized TCP connections that were closed normally since TFO was started, or since its statistics were last reset.                                                                                                                                                                                                                                                                                                                                                                                                                                                                                                                                                                                                                                       |
| cwoTfoStatsResetConn             | The total number of optimized TCP connections that have been reset since TFO was started or since its statistics were last reset.                                                                                                                                                                                                                                                                                                                                                                                                                                                                                                                                                                                                                                             |

## cwoTfoStats MIB Objects for TFO Current Connection Information

Table 17-33 TFO Current Connection MIB Objects

| MIB Object                      | Description                                                                                                                    |
|---------------------------------|--------------------------------------------------------------------------------------------------------------------------------|
| cwoTfoStatsActiveOptConn        | The number of active TCP connections that are getting optimized.                                                               |
| cwoTfoStatsMaxActiveConn        | The maximum number of active TCP connections that the specified device can optimize.                                           |
| cwoTfoStatsActivePTConn         | The number of active pass-through TCP connections.                                                                             |
| cwoTfoStatsActiveOptTCPPlusConn | The number of active TCP connections going through TCP plus other optimization.                                                |
| cwoTfoStatsActiveOptTCPOnlyConn | The number of active TCP connections going through TCP optimization only.                                                      |
| cwoTfoStatsActiveOptTCPPrepConn | The number of active TCP connections that were originated by an accelerator to acquire data in anticipation of its future use. |

| MIB Object                   | Description                                                                                 |
|------------------------------|---------------------------------------------------------------------------------------------|
| cwoTfoStatsStatsActiveADConn | The number of current active TCP connections in the auto-discovery state.                   |
| cwoTfoStatsReservedConn      | The number of TCP connections that are reserved for the MAPI accelerator.                   |
| cwoTfoStatsPendingConn       | The number of TCP connections that are pending in the queue of connections to be optimized. |

## Downloading MIB Files

You can download the MIB files for most of the MIBs that are supported by a device that is running the WAAS software from the following Cisco FTP site:

<ftp://ftp.cisco.com/pub/mibs/v2>

You can download the RFC1213-MIB file (for MIB-II) from the following Cisco FTP site:

<ftp://ftp.cisco.com/pub/mibs/v1>

The MIB objects that are defined in each MIB are described in the MIB files at the above FTP sites and are self-explanatory.

## Using MIBs to Monitor WAAS

This section contains usage examples and sample output for using MIB files to monitor WAAS:

- [Using MIBs to Display Alarm Status](#)
- [Using MIBs to Display AO Information and Status](#)
- [Using MIBs to Display DRE Cache and Performance Information](#)
- [Using MIBs to Display Interface Information](#)
- [Using MIBs to Display TFO Information](#)

### Using MIBs to Display Alarm Status

This section provides usage examples and sample output for WAAS alarm information. For more information on these MIBs, see [Alarms \(CISCO-CONTENT-ENGINE-MIB\)](#).

- To verify that there are no alarms on the system, use **cceAlarm**:

```
CISCO-CONTENT-ENGINE-MIB::cceAlarmMinorCount.0 = Gauge32: 0
CISCO-CONTENT-ENGINE-MIB::cceAlarmMajorCount.0 = Gauge32: 0
CISCO-CONTENT-ENGINE-MIB::cceAlarmCriticalCount.0 = Gauge32: 0
```

### Using MIBs to Display AO Information and Status

This section provides usage examples and sample MIB output for WAAS AO information and status. For more information on these MIBs, see [AOs \(CISCO-WAN-OPTIMIZATION-MIB\)](#).

- To verify the configuration status of WAAS AOs, use **cwoAoStatsIsConfigured**:

```
CISCO-WAN-OPTIMIZATION-MIB::cwoAoStatsIsConfigured."epm" = INTEGER: true(1)
CISCO-WAN-OPTIMIZATION-MIB::cwoAoStatsIsConfigured."ica" = INTEGER: false(2)
```



```
CISCO-WAN-OPTIMIZATION-MIB::cwoAoStatsIsConfigured."nfs" = INTEGER: true(1)
CISCO-WAN-OPTIMIZATION-MIB::cwoAoStatsIsConfigured."smb" = INTEGER: true(1)
CISCO-WAN-OPTIMIZATION-MIB::cwoAoStatsIsConfigured."ssl" = INTEGER: true(1)
CISCO-WAN-OPTIMIZATION-MIB::cwoAoStatsIsConfigured."http" = INTEGER: true(1)
CISCO-WAN-OPTIMIZATION-MIB::cwoAoStatsIsConfigured."mapi" = INTEGER: true(1)
```

- To verify the operational state of configured WAAS AOs, use **cwoAoStatsOperationalState**:

```
CISCO-WAN-OPTIMIZATION-MIB::cwoAoStatsOperationalState."epm" = INTEGER: normalRunning(3)
CISCO-WAN-OPTIMIZATION-MIB::cwoAoStatsOperationalState."ica" = INTEGER: shutdown(1)
CISCO-WAN-OPTIMIZATION-MIB::cwoAoStatsOperationalState."nfs" = INTEGER: normalRunning(3)
CISCO-WAN-OPTIMIZATION-MIB::cwoAoStatsOperationalState."smb" = INTEGER: normalRunning(3)
CISCO-WAN-OPTIMIZATION-MIB::cwoAoStatsOperationalState."ssl" = INTEGER: normalRunning(3)
```

## Using MIBs to Display DRE Cache and Performance Information

This section provides usage examples and sample MIB output for DRE cache and performance information.

For overview information on these MIBs, see [DRE Cache \(CISCO-WAN-OPTIMIZATION-MIB\)](#) and [DRE Performance \(CISCO-WAN-OPTIMIZATION-MIB\)](#).

- To verify if DRE is operational and the DRE is in a usable state (the DRE states are Initializing, Usable, Failed), use **cwoDreCacheStatsStatus**:

```
CISCO-WAN-OPTIMIZATION-MIB::cwoDreCacheStatsStatus.0 = STRING: Usable
```

- To display DRE cache age, use **cwoDreCacheStatsAge**:

```
CISCO-WAN-OPTIMIZATION-MIB::cwoDreCacheStatsAge.0 = STRING: 5d17h
```



### Note

On both branch and datacenter devices, the cache age should provide an effective capacity-to-reduction ratio. It is important that you baseline this value and set triggers according to your specific use case.

*For a datacenter device*, the cache age should be approximately 5-7 days. However, there are scenarios where your cache age could be much lower and WAAS is still providing a very good reduction ratio; for example, in replication or backup scenarios.

*For a branch device*, the cache age in practice will likely be more than 5-7 days.

- To display DRE cache information, including the portion of the disk space allocated for DRE cache, the age of the oldest data unit the data block, and the amount of data units replaced in the last hour, use **cwoDreCacheStats** MIB objects:

```
CISCO-WAN-OPTIMIZATION-MIB::cwoDreCacheStatsTotal.0 = Counter64: 77822 MB
CISCO-WAN-OPTIMIZATION-MIB::cwoDreCacheStatsUsed.0 = Gauge32: 96 percent
CISCO-WAN-OPTIMIZATION-MIB::cwoDreCacheStatsDataUnitUsage.0 = Counter64: 0 MB
CISCO-WAN-OPTIMIZATION-MIB::cwoDreCacheStatsReplacedOneHrDataUnit.0 = Counter64: 0 MB
CISCO-WAN-OPTIMIZATION-MIB::cwoDreCacheStatsDataUnitAge.0 = STRING: 0s
CISCO-WAN-OPTIMIZATION-MIB::cwoDreCacheStatsSigblockUsage.0 = Counter64: 1695 MB
CISCO-WAN-OPTIMIZATION-MIB::cwoDreCacheStatsReplacedOneHrSigblock.0 = Counter64: 0 MB
CISCO-WAN-OPTIMIZATION-MIB::cwoDreCacheStatsSigblockAge.0 = STRING: 14d17h
```

- To display compression ratio values, use **cwoDrePerfStats** MIB objects. For datacenter devices, it is especially useful to view Encode compression ratio values, and for branch devices, it is especially useful to view Decode compression ratio values.

```
CISCO-WAN-OPTIMIZATION-MIB::cwoDrePerfStatsEncodeCompressionRatio.0 = Gauge32: 9 percent
```

```
CISCO-WAN-OPTIMIZATION-MIB::cwoDrePerfStatsDecodeCompressionRatio.0 = Gauge32: 51 percent
```

- To display compression latency values, use **cwoDrePerfStats** MIB objects. For datacenter devices, it is especially useful to view Encode compression latency values, and for branch devices, it is especially useful to view Decode compression latency values.

```
CISCO-WAN-OPTIMIZATION-MIB::cwoDrePerfStatsEncodeCompressionLatency.0 = Counter64: 0 ms
CISCO-WAN-OPTIMIZATION-MIB::cwoDrePerfStatsDecodeCompressionLatency.0 = Counter64: 0 ms
```



**Note** Set a baseline for the latency value. If the latency value begins to deviate higher than normal, it could indicate a potential disk problem or failing disk, or it could indicate that a new traffic pattern is driving higher than normal disk input/output.

- To display the average size of all the messages handled by DRE during encoding or decoding, use **cwoDrePerfStats** MIB objects:

```
CISCO-WAN-OPTIMIZATION-MIB::cwoDrePerfStatsEncodeAvgMsgSize.0 = STRING: 1991 B
CISCO-WAN-OPTIMIZATION-MIB::cwoDrePerfStatsDecodeAvgMsgSize.0 = STRING: 1082 B
```

## Using MIBs to Display Interface Information

This section provides usage examples and sample MIB output for interface information—description, status, and transmission errors and discards. For more information on these MIBs, see [Interfaces \(IF-MIB\)](#).

- To check the up/down status of your interfaces, use **ifDescr**, **ifAdminStatus**, and **ifOperStatus**.

```
IF-MIB::ifDescr.1 = STRING: GigabitEthernet 0/0
IF-MIB::ifDescr.2 = STRING: GigabitEthernet 0/1
IF-MIB::ifAdminStatus.1 = INTEGER: up(1)
IF-MIB::ifAdminStatus.2 = INTEGER: up(1)
IF-MIB::ifOperStatus.1 = INTEGER: up(1)
IF-MIB::ifOperStatus.2 = INTEGER: down(2)
```

- To check if there are any transmission-related errors which could point to L1 and L2 problems (e.g. bad cable or speed/duplex mismatch on connected switch/router), use **ifInErrors** and **ifInDiscards**.

```
IF-MIB::ifInErrors.1 = Counter32: 0
IF-MIB::ifInErrors.2 = Counter32: 0
IF-MIB::ifOutErrors.1 = Counter32: 0
IF-MIB::ifOutErrors.2 = Counter32: 0
IF-MIB::ifInDiscards.1 = Counter32: 0
IF-MIB::ifInDiscards.2 = Counter32: 0
IF-MIB::ifOutDiscards.1 = Counter32: 0
IF-MIB::ifOutDiscards.2 = Counter32: 0
```

## Using MIBs to Display TFO Information

This section provides usage examples and sample MIB output for TFO information and status. For more information on these MIBs, see [TFO \(CISCO-WAN-OPTIMIZATION-MIB\)](#).

This section contains the following topics:

- [Performing Trend and Baseline Analysis with TFO MIBs](#)
- [Displaying Connection Information Using cwoTfoStats](#)
- [Displaying TFO Auto-Discovery and Load Status Information Using cwoTfoStats](#)

## Performing Trend and Baseline Analysis with TFO MIBs

To be able to assess what normal load and benefits WAAS provides for your network, we recommend that you perform some trend and baseline analysis. Then, based on the results, you can create traps and alerts if the counters are above or below your defined thresholds - whichever is appropriate for the specific counter.

To monitor the system to determine if, from a connection standpoint, you need a larger device, follow these steps:

- 
- Step 1** To verify key connection information, use the following MIB to verify the maximum number of connections the system can optimize.

```
CISCO-WAN-OPTIMIZATION-MIB::cwoTfoStatsMaxActiveConn.0 = Counter64: 750
```

- Step 2** Use the following MIB object to verify the total number of active optimized connections:

```
CISCO-WAN-OPTIMIZATION-MIB::cwoTfoStatsActiveOptConn.0 = Counter64: 21
```

- Step 3** After verifying the maximum number of connections and the total active optimized connections, you can do one of the following:

- Set an alert in your monitoring tool.
- Or
- Set an SNMP trap if the number gets close to the limit on a consistent basis.

For example, the WAAS poll interval is every 5 minutes. An alert is triggered if within a 1-hour or 4-hour period the *total number of active optimized connections* crosses 90% of the *maximum number of connections the system can optimize* 10 times.

For how to set an SNMP trap, see [Enabling SNMP Traps](#).

---

## Displaying Connection Information Using cwoTfoStats

To display connection information, use **cwoTfoStats** MIB objects:

```
CISCO-WAN-OPTIMIZATION-MIB::cwoTfoStatsTotalNormalClosedConn.0 = 0
CISCO-WAN-OPTIMIZATION-MIB::cwoTfoStatsPendingConn.0 = 0
CISCO-WAN-OPTIMIZATION-MIB::cwoTfoStatsReservedConn.0 = 0
CISCO-WAN-OPTIMIZATION-MIB::cwoTfoStatsResetConn.0 = 0
CISCO-WAN-OPTIMIZATION-MIB::cwoTfoStatsOptConn.0 = 0
CISCO-WAN-OPTIMIZATION-MIB::cwoTfoStatsMaxActiveConn.0 = 0
CISCO-WAN-OPTIMIZATION-MIB::cwoTfoStatsTotalOptConn.0 = 0
CISCO-WAN-OPTIMIZATION-MIB::cwoTfoStatsActivePTConn.0 = 0
```

## Displaying TFO Auto-Discovery and Load Status Information Using cwoTfoStats

To display TFO auto-discovery and load status information, use **cwoTfoStats**:

```
CISCO-WAN-OPTIMIZATION-MIB::cwoTfoStatsActiveADConn.0 = 0
CISCO-WAN-OPTIMIZATION-MIB::cwoTfoStatsLoadStatus.0 = INTEGER: green(2)
```



### Note

If the TFO load status shows Unknown(1), Yellow(3) or Red(4), then the TFO is overloaded or has some other error condition, and no optimization can occur at any other level, such as DRE, LZ, or AO.

---

## Enabling the SNMP Agent on a WAAS Device

By default, the SNMP agent on WAAS devices is disabled and an SNMP community string is not defined. The SNMP community string is used as a password for authentication when accessing the SNMP agent on a WAAS device. To be authenticated, the Community Name field of any SNMP message sent to the WAAS device must match the SNMP community string defined on the WAAS device.

The SNMP agent on a WAAS device is enabled when you define the SNMP community string on the device. The WAAS Central Manager GUI allows you to define the SNMP community string on a device or device group.

If the SNMPv3 protocol is going to be used for SNMP requests, the next step is to define an SNMP user account that can be used to access a WAAS device through SNMP. For more information on how to create an SNMPv3 user account on a WAAS device, see [Creating an SNMP User](#).

## Checklist for Configuring SNMP

[Table 17-34](#) describes the process for enabling SNMP monitoring on a WAAS device or device group.

**Table 17-34** Checklist for Configuring SNMP

| Task                                                   | Additional Information and Instructions                                                                                                                                                                                                                                                      |
|--------------------------------------------------------|----------------------------------------------------------------------------------------------------------------------------------------------------------------------------------------------------------------------------------------------------------------------------------------------|
| 1. Prepare for SNMP monitoring.                        | For more information, see <a href="#">Preparing for SNMP Monitoring</a> .                                                                                                                                                                                                                    |
| 2. Select the SNMP traps that you want to enable.      | The WAAS Central Manager provides a wide-range of traps that you can enable on a WAAS device or device group.<br><br>For more information, see <a href="#">Enabling SNMP Traps</a> . To define additional traps, see <a href="#">Defining SNMP Triggers to generate User-Defined Traps</a> . |
| 3. Specify the SNMP host that receives the SNMP traps. | Specify the SNMP host to that the WAAS device or device group should send their traps to. You can specify multiple hosts so different WAAS devices send traps to different hosts.<br><br>For more information, see <a href="#">Specifying the SNMP Host</a> .                                |
| 4. Specify the SNMP community string.                  | Specify the SNMP community string so external users can read or write to the MIB.<br><br>For more information, see <a href="#">Specifying the SNMP Community String</a> .                                                                                                                    |
| 5. Set up SNMP views.                                  | To restrict an SNMP group to a specific view, you must create a view that specifies the MIB subtree that you want the group to view.<br><br>For more information, see <a href="#">Creating SNMP Views</a> .                                                                                  |
| 6. Create an SNMP group.                               | You must set up an SNMP group if are going to create any SNMP users or want to restrict a group to view a specific MIB subtree.<br><br>For more information, see <a href="#">Creating an SNMP Group</a> .                                                                                    |
| 7. Create an SNMP user.                                | If the SNMPv3 protocol is going to be used for SNMP requests, you must create at least one SNMPv3 user account on the WAAS device in order for the WAAS device to be accessed through SNMP.<br><br>For more information, see <a href="#">Creating an SNMP User</a> .                         |
| 8. Configure SNMP contact settings.                    | For more information, see <a href="#">Configuring SNMP Contact Settings</a> .                                                                                                                                                                                                                |

## Preparing for SNMP Monitoring

Before you configure your WAAS network for SNMP monitoring, complete the following preparation tasks:

- Set up the SNMP host (management station) that the WAAS devices will use to send SNMP traps.
- Determine if all your WAAS devices will be sending traps to the same host, or to different hosts. Write down the IP address or hostname of each SNMP host.
- Obtain the community string used to access the SNMP agents.
- Determine if you want to create SNMP groups so you can restrict views by group.
- Determine what additional SNMP traps you need.
- Clock synchronization between the devices in a WAAS network is important. On each WAAS device, be sure to set up a Network Time Protocol (NTP) server to keep the clocks synchronized.

## Enabling SNMP Traps

To enable a WAAS device to send SNMP traps, follow these steps:

- 
- Step 1** From the WAAS Central Manager menu, choose **Devices** > *device-name* (or **Device Groups** > *device-group-name*).
- Step 2** Choose **Configure** > **Monitoring** > **SNMP** > **General Settings**. The SNMP General Settings window appears. (See [Figure 17-4](#).) [Table 17-35](#) describes the fields in this window.

Figure 17-4 SNMP General Settings Window

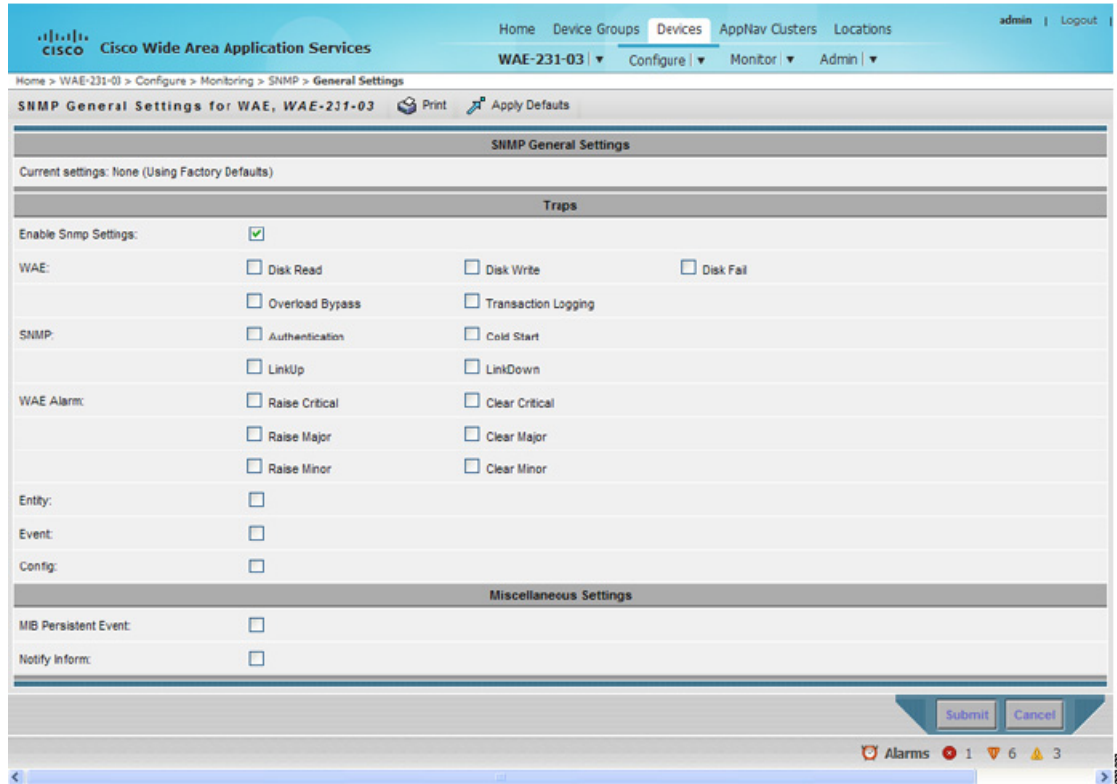

Table 17-35 SNMP General Settings

| GUI Parameter        | Function                                                                                                                                                                                                                                                                                                                                                                    |
|----------------------|-----------------------------------------------------------------------------------------------------------------------------------------------------------------------------------------------------------------------------------------------------------------------------------------------------------------------------------------------------------------------------|
| <b>Traps</b>         |                                                                                                                                                                                                                                                                                                                                                                             |
| Enable Snmp Settings | Enables SNMP traps.                                                                                                                                                                                                                                                                                                                                                         |
| WAE                  | Enables SNMP WAE traps: <ul style="list-style-type: none"> <li>• Disk Read—Enables disk read error trap.</li> <li>• Disk Write—Enables disk write error trap.</li> <li>• Disk Fail—Enables disk failure error trap.</li> <li>• Overload Bypass—Enables WCCP overload bypass error trap.</li> <li>• Transaction Logging—Enables transaction log write error trap.</li> </ul> |
| SNMP                 | Enables SNMP-specific traps: <ul style="list-style-type: none"> <li>• Authentication—Enables authentication trap.</li> <li>• Cold Start—Enables cold start trap.</li> <li>• LinkUp—Link up trap.</li> <li>• LinkDown—Link down trap.</li> </ul>                                                                                                                             |

Table 17-35 *SNMP General Settings (continued)*

| GUI Parameter                 | Function                                                                                                                                                                                                                                                                                                                                                                                                                                                                                                                                                                       |
|-------------------------------|--------------------------------------------------------------------------------------------------------------------------------------------------------------------------------------------------------------------------------------------------------------------------------------------------------------------------------------------------------------------------------------------------------------------------------------------------------------------------------------------------------------------------------------------------------------------------------|
| WAE Alarm                     | Enables WAE alarm traps: <ul style="list-style-type: none"> <li>• Raise Critical—Enables raise-critical alarm trap</li> <li>• Clear Critical—Enables clear-critical alarm trap</li> <li>• Raise Major—Enables raise-major alarm trap</li> <li>• Clear Major—Enables clear-major alarm trap</li> <li>• Raise Minor—Enables raise-minor alarm trap</li> <li>• Clear Minor—Enables clear-minor alarm trap</li> </ul>                                                                                                                                                              |
| Entity                        | Enables SNMP entity traps.                                                                                                                                                                                                                                                                                                                                                                                                                                                                                                                                                     |
| Event                         | Enables the Event MIB.                                                                                                                                                                                                                                                                                                                                                                                                                                                                                                                                                         |
| Config                        | Enables CiscoConfigManEvent error traps.                                                                                                                                                                                                                                                                                                                                                                                                                                                                                                                                       |
| <b>Miscellaneous Settings</b> |                                                                                                                                                                                                                                                                                                                                                                                                                                                                                                                                                                                |
| MIB Persistent Event          | Enables persistence for the SNMP Event MIB. (This check box is not shown when the selected device is a Central Manager.)                                                                                                                                                                                                                                                                                                                                                                                                                                                       |
| Notify Inform                 | Enables the SNMP notify inform request. Inform requests are more reliable than traps but consume more resources in the router and in the network.<br><br>Traps are unreliable because the receiver does not send any acknowledgment when it receives a trap. The sender cannot determine if the trap was received. However, an SNMP manager that receives an inform request acknowledges the message with an SNMP response. If the sender never receives a response, the inform request can be sent again. Thus, informs are more likely to reach their intended destinations. |

**Step 3** Check the appropriate check boxes to enable SNMP traps.

**Step 4** Click **Submit**.

A “Click Submit to Save” message appears in red next to the current settings when there are pending changes to be saved after you have applied default or device group settings. You can also revert to the previously configured window settings by clicking **Reset**. The Reset button is visible only when you apply default or device group settings to change the current device settings but the settings have not yet been submitted.

To enable SNMP traps from the CLI, you can use the **snmp-server enable traps** global configuration command.

To control access to the SNMP agent by an external SNMP server, use the **snmp-server access-list** global configuration command to apply an SNMP ACL.



**Note**

If you are using an SNMP server ACL, you must permit the loopback interface.

**Note**

If you override the device group settings from the SNMP General Settings window, the Central Manager deletes the SNMP community, SNMP group, SNMP user, SNMP view, and SNMP host settings. You are asked to confirm this behavior.

To define additional SNMP traps for other MIB objects of interest to your particular configuration, see [Defining SNMP Triggers to generate User-Defined Traps](#).

## Defining SNMP Triggers to generate User-Defined Traps

To define additional SNMP traps for other MIB objects of interest to your particular configuration, follow these steps to create additional SNMP triggers:

- Step 1** From the WAAS Central Manager menu, choose **Devices > device-name** (or **Device Groups > device-group-name**).
- Step 2** Choose **Configure > Monitoring > SNMP > Trigger**. The SNMP Trigger List Entries window appears. The columns in this window are the same as the parameters described in [Table 17-36](#).
- Step 3** In the taskbar, click the **Create New SNMP Trigger List Entry** icon. The Creating New SNMP Trigger window appears. [Table 17-36](#) describes the fields in this window.

**Table 17-36** Creating New SNMP Trigger Settings

| GUI Parameter | Function                                                                                                                                                                                                                                                                                                                                                                                                                                                                                                                                                                                                                                                                                                                                                                                                                                                                            |
|---------------|-------------------------------------------------------------------------------------------------------------------------------------------------------------------------------------------------------------------------------------------------------------------------------------------------------------------------------------------------------------------------------------------------------------------------------------------------------------------------------------------------------------------------------------------------------------------------------------------------------------------------------------------------------------------------------------------------------------------------------------------------------------------------------------------------------------------------------------------------------------------------------------|
| Trigger Name  | Custom defined name for the notification trigger that you want to monitor.                                                                                                                                                                                                                                                                                                                                                                                                                                                                                                                                                                                                                                                                                                                                                                                                          |
| MIB Name      | MIB variable name of the object that you want to monitor.                                                                                                                                                                                                                                                                                                                                                                                                                                                                                                                                                                                                                                                                                                                                                                                                                           |
| Wild Card     | (Optional) Check this check box if the MIB Name value is a wildcard. Note that this check box is disabled when editing the SNMP Trigger.                                                                                                                                                                                                                                                                                                                                                                                                                                                                                                                                                                                                                                                                                                                                            |
| Frequency     | Number of seconds (60–600) to wait between trigger samples.                                                                                                                                                                                                                                                                                                                                                                                                                                                                                                                                                                                                                                                                                                                                                                                                                         |
| Test          | Test used to trigger the SNMP trap. Choose one of the following tests: <ul style="list-style-type: none"> <li>• absent—A specified MIB object that was present at the last sampling is no longer present as of the current sampling.</li> <li>• equal—The value of the specified MIB object is equal to the specified threshold.</li> <li>• greater-than—The value of the specified MIB object is greater than the specified threshold value.</li> <li>• less-than—The value of the specified MIB object is less than the specified threshold value.</li> <li>• on-change—The value of the specified MIB object has changed since the last sampling.</li> <li>• present—A specified MIB object is present as of the current sampling that was not present at the previous sampling.</li> <li>• threshold- Configures a maximum and a minimum threshold for a MIB object.</li> </ul> |



**Table 17-36** *Creating New SNMP Trigger Settings (continued)*

| GUI Parameter                    | Function                                                                                                                                                                                                                                                                                                                |
|----------------------------------|-------------------------------------------------------------------------------------------------------------------------------------------------------------------------------------------------------------------------------------------------------------------------------------------------------------------------|
| Sample Type                      | (Optional) Sample type, as follows: <ul style="list-style-type: none"> <li>absolute—The test is evaluated against a fixed integer value between zero and 2147483647.</li> <li>delta—The test is evaluated against the change in the MIB object value between the current sampling and the previous sampling.</li> </ul> |
| Threshold Value                  | Threshold value of the MIB object. This field is not used if absent, on-change, or present is chosen in the Test drop-down list.                                                                                                                                                                                        |
| MIB Var1<br>MIB Var2<br>MIB Var3 | (Optional) Names of up to three alternate MIB variables to add to the notification. Validation of these names is not supported, so be sure to enter them correctly.                                                                                                                                                     |
| Comments                         | Description of the trap.                                                                                                                                                                                                                                                                                                |

**Step 4** In the appropriate fields, enter the MIB name, frequency, test, sample type, threshold value, and comments.



**Note** You can create valid triggers only on read-write and read-only MIB objects. If you create a trigger on a read-create MIB object, it is deleted from the Central Manager configuration after one data feed poll cycle.

**Step 5** Click **Submit**.

The new SNMP trigger is listed in the SNMP Trigger List window.

You can edit an SNMP trigger by clicking the **Edit** icon next to the MIB name in the SNMP Trigger List Entries window.

You can delete an SNMP trigger by clicking the **Edit** icon next to the MIB name and then clicking the **Delete** taskbar icon.



**Note** If you delete any of the default SNMP triggers, they will be restored after a reload.



**Note** When you upgrade a WAE from an earlier version to the 6.0 version, all triggers are deleted.

When you upgrade the Central Manager to 6.0, all the Device Group triggers will be copied to a WAE running a previous software version (if any) and all the Device Group triggers will be deleted. Also the Trigger Aggregate Settings will be set to false for all the WAES (running a version earlier than 6.0) that are being managed by the Central Manager (running version 6.0). This ensures that the DG triggers are no longer applied to any of the devices running a version earlier than 6.0.



**Note** When you downgrade a WAE from a 6.0 to an earlier release all the IPv6 configurations will be removed. All the triggers and the monitor user configurations are deleted.

You can use the **snmp trigger** global configuration command to define SNMP traps from the CLI. To control access to the SNMP agent by an external SNMP server, use the **snmp-server access-list** global configuration command to apply an SNMP ACL.

**Note**

If you are using an SNMP server ACL, you must permit the loopback interface.

## Aggregating SNMP Triggers

An individual WAE device can have custom SNMP triggers defined and can belong to device groups that have other custom SNMP triggers defined.

In the SNMP Trigger List Entries window, the Aggregate Settings radio button controls how SNMP triggers are aggregated for an individual device, as follows:

- Choose **Yes** if you want to configure the device with all custom SNMP triggers that are defined for itself and for device groups to which it belongs.
- Choose **No** if you want to limit the device to just the custom SNMP triggers that are defined for itself.

When you change the setting, you get the following confirmation message: “This option will take effect immediately and will affect the device configuration. Do you wish to continue?” Click **OK** to continue.

## Specifying the SNMP Host

Hosts are listed in the order in which they have been created. The maximum number of SNMP hosts that can be created is four.

To specify the SNMP host, follow these steps:

- Step 1** From the WAAS Central Manager menu, choose **Devices > device-name** (or **Device Groups > device-group-name**).
- Step 2** Choose **Configure > Monitoring > SNMP > Host**. The SNMP Hosts window appears.
- Step 3** In the taskbar, click the **Create New SNMP Host** icon. The Creating New SNMP Host window appears. [Table 17-37](#) describes the fields in this window.

**Table 17-37** *SNMP Host Settings*

| GUI Parameter  | Function                                                                                                                                                |
|----------------|---------------------------------------------------------------------------------------------------------------------------------------------------------|
| Trap Host      | Hostname or IP address of the SNMP trap host that is sent in SNMP trap messages from the WAE. This is a required field and now supports IPv6 addresses. |
| Community/User | Name of the SNMP community or user (64 characters maximum) that is sent in SNMP trap messages from the WAE. This is a required field.                   |

**Table 17-37** *SNMP Host Settings (continued)*

| GUI Parameter  | Function                                                                                                                                                                                                                                                                                                                                                                                                                                                                                                                                                                                                        |
|----------------|-----------------------------------------------------------------------------------------------------------------------------------------------------------------------------------------------------------------------------------------------------------------------------------------------------------------------------------------------------------------------------------------------------------------------------------------------------------------------------------------------------------------------------------------------------------------------------------------------------------------|
| Authentication | Security model to use for sending notification to the recipient of an SNMP trap operation. Choose one of the following options from the drop-down list: <ul style="list-style-type: none"> <li>• <b>No-auth</b>—Sends notification without any security mechanism.</li> <li>• <b>v2c</b>—Sends notification using Version 2c security.</li> <li>• <b>v3-auth</b>—Sends notification using SNMP Version 3 AuthNoPriv.</li> <li>• <b>v3-noauth</b>—Sends notification using SNMP Version 3 NoAuthNoPriv security.</li> <li>• <b>v3-priv</b>—Sends notification using SNMP Version 3 AuthPriv security.</li> </ul> |
| Retry          | Number of retries (1–10) allowed for the inform request. The default is 2 tries.                                                                                                                                                                                                                                                                                                                                                                                                                                                                                                                                |
| Timeout        | Timeout for the inform request in seconds (1–1000). The default is 15 seconds.                                                                                                                                                                                                                                                                                                                                                                                                                                                                                                                                  |

**Step 4** Enter the hostname or IP address of an SNMP trap host, SNMP community or user name, security model to send notification, and retry count and timeout for inform requests.

**Step 5** Click **Submit**.

To specify the SNMP host from the CLI, you can use the **snmp-server host** global configuration command.

## Specifying the SNMP Community String

An SNMP community string is the password used to access an SNMP agent that resides on WAAS devices. There are two types of community strings: group and read-write. Community strings enhance the security of your SNMP messages.

Community strings are listed in the order in which they have been created. The maximum number of SNMP communities that can be created is ten. By default, an SNMP agent is disabled, and a community string is not configured. When a community string is configured, it permits read-only access to all agents by default.

To enable the SNMP agent and configure a community string to permit access to the SNMP agent, follow these steps:

**Step 1** From the WAAS Central Manager menu, choose **Devices > device-name** (or **Device Groups > device-group-name**).

**Step 2** Choose **Configure > Monitoring > SNMP > Community**. The SNMP Community Strings window appears.

**Step 3** In the taskbar, click the **Create New SNMP Community String** icon. The Creating New SNMP Community String window appears. [Table 17-38](#) describes the fields in this window.

**Table 17-38** *SNMP Community Settings*

| GUI Parameter | Function                                                                                                                                                                                                                                                                                                                                                                                                                                                                                                                                                                                                                                                                                                                                                                                                                                                 |
|---------------|----------------------------------------------------------------------------------------------------------------------------------------------------------------------------------------------------------------------------------------------------------------------------------------------------------------------------------------------------------------------------------------------------------------------------------------------------------------------------------------------------------------------------------------------------------------------------------------------------------------------------------------------------------------------------------------------------------------------------------------------------------------------------------------------------------------------------------------------------------|
| Community     | Community string used as a password for authentication when you access the SNMP agent of the WAE. The “Community Name” field of any SNMP message sent to the WAE must match the community string defined here in order to be authenticated. Entering a community string enables the SNMP agent on the WAE. You can enter a maximum of 64 characters in this field.<br><br>This is a required field.                                                                                                                                                                                                                                                                                                                                                                                                                                                      |
| Group name/rw | Group to which the community string belongs. The Read/Write option allows a read or write group to be associated with this community string. The Read/Write option permits access to only a portion of the MIB subtree. Choose one of the following three options from the drop-down list: <ul style="list-style-type: none"> <li>• <b>None</b>—Choose this option if you do not want to specify a group name to be associated with the community string. The Group Name field remains disabled if you select this option.</li> <li>• <b>Group</b>—Choose this option if you want to specify a group name.</li> <li>• <b>Read/Write</b>—Choose this option if you want to allow read-write access to the group associated with a community string. The Group Name field remains disabled if you select this option.</li> </ul> This is a required field. |
| Group Name    | Name of the group to which the community string belongs. You can enter a maximum of 64 characters in this field. This field is available only if you have chosen the Group option in the previous field.                                                                                                                                                                                                                                                                                                                                                                                                                                                                                                                                                                                                                                                 |

**Step 4** In the appropriate fields, enter the community string, choose whether or not read-write access to the group is allowed, and enter the group name.

**Step 5** Click **Submit**.

To configure a community string from the CLI, you can use the **snmp-server community** global configuration command.

## Creating SNMP Views

To restrict a group of users to view a specific MIB tree, you must create an SNMP view using the WAAS Central Manager GUI. Once you create the view, you need to create an SNMP group and SNMP users that belong to this group as described in later sections.

Views are listed in the order in which they have been created. The maximum number of views that can be created is ten.

To create a Version 2 SNMP (SNMPv2) MIB view, follow these steps:

**Step 1** From the WAAS Central Manager menu, choose **Devices > device-name** (or **Device Groups > device-group-name**).

**Step 2** Choose **Configure > Monitoring > SNMP > View**. The SNMP Views window appears.

- Step 3** In the taskbar, click the **Create New View** icon. The Creating New SNMP View window appears. [Table 17-39](#) describes the fields in this window.

**Table 17-39** *SNMPv2 View Settings*

| GUI Parameter | Function                                                                                                                                                                                                                                                                                                                                  |
|---------------|-------------------------------------------------------------------------------------------------------------------------------------------------------------------------------------------------------------------------------------------------------------------------------------------------------------------------------------------|
| Name          | String representing the name of this family of view subtrees (64 characters maximum). The family name must be a valid MIB name such as ENTITY-MIB. This is a required field.                                                                                                                                                              |
| Family        | Object identifier (64 characters maximum) that identifies a subtree of the MIB. This is a required field.                                                                                                                                                                                                                                 |
| View Type     | View option that determines the inclusion or exclusion of the MIB family from the view. Choose one of the following two options from the drop-down list: <ul style="list-style-type: none"> <li>• <b>Included</b>—The MIB family is included in the view.</li> <li>• <b>Excluded</b>—The MIB family is excluded from the view.</li> </ul> |

- Step 4** In the appropriate fields, enter the view name, the family name, and the view type.
- Step 5** Click **Submit**.
- Step 6** Create an SNMP group that will be assigned to this view as described in the section that follows.

To create an SNMP view from the CLI, you can use the **snmp-server view** global configuration command.

## Creating an SNMP Group

You must set up an SNMP group if you are going to create any SNMP users or want to restrict a group of users to view a specific MIB subtree.

Groups are listed in the order in which they have been created. The maximum number of SNMP groups that can be created is ten.

To define a user security model group, follow these steps:

- Step 1** From the WAAS Central Manager menu, choose **Devices > device-name** (or **Device Groups > device-group-name**).
- Step 2** Choose **Configure > Monitoring > SNMP > Group**. The SNMP Group Strings for WAE window appears.
- Step 3** In the taskbar, click the **Create New SNMP Group String** icon. The Creating New SNMP Group String for WAE window appears. [Table 17-40](#) describes the fields in this window.

**Table 17-40** SNMP Group Settings

| GUI Parameter | Function                                                                                                                                                                                                                                                                                                                                                                                                                                                                                                                                                                                                                                                                                                                                                                                          |
|---------------|---------------------------------------------------------------------------------------------------------------------------------------------------------------------------------------------------------------------------------------------------------------------------------------------------------------------------------------------------------------------------------------------------------------------------------------------------------------------------------------------------------------------------------------------------------------------------------------------------------------------------------------------------------------------------------------------------------------------------------------------------------------------------------------------------|
| Name          | Name of the SNMP group. You can enter a maximum of 64 characters. This is a required field.                                                                                                                                                                                                                                                                                                                                                                                                                                                                                                                                                                                                                                                                                                       |
| Sec Model     | <p>Security model for the group. Choose one of the following options from the drop-down list:</p> <ul style="list-style-type: none"> <li><b>v1</b>—Version 1 security model (SNMP Version 1 [noAuthNoPriv]).</li> <li><b>v2c</b>—Version 2c security model (SNMP Version 2 [noAuthNoPriv]).</li> <li><b>v3-auth</b>—User security level SNMP Version 3 AuthNoPriv.</li> <li><b>v3-noauth</b>—User security level SNMP Version 3 noAuthNoPriv.</li> <li><b>v3-priv</b>—User security level SNMP Version 3 AuthPriv.</li> </ul> <p> <b>Note</b> A group defined with the SNMPv1 or SNMPv2c security model should not be associated with SNMP users; they should only be associated with the community strings.</p> |
| Read View     | <p>Name of the view (a maximum of 64 characters) that enables you only to view the contents of the agent. By default, no view is defined. In order to provide read access to users of the group, a view must be specified.</p> <p>For information on creating SNMP views, see <a href="#">Creating SNMP Views</a>.</p>                                                                                                                                                                                                                                                                                                                                                                                                                                                                            |
| Write View    | <p>Name of the view (a maximum of 64 characters) that enables you to enter data and configure the contents of the agent. By default, no view is defined.</p> <p>For information on creating SNMP views, see <a href="#">Creating SNMP Views</a>.</p>                                                                                                                                                                                                                                                                                                                                                                                                                                                                                                                                              |
| Notify View   | <p>Name of the view (a maximum of 64 characters) that enables you to specify a notify, inform, or trap. By default, no view is defined.</p> <p>For information on creating SNMP views, see <a href="#">Creating SNMP Views</a>.</p>                                                                                                                                                                                                                                                                                                                                                                                                                                                                                                                                                               |

- Step 4** In the appropriate fields, enter the SNMP group configuration name, the security model, and the names of the read, write, and notify views.
- Step 5** Click **Submit**.
- Step 6** Create SNMP users that belong to this new group as described in the section that follows.

---

To create an SNMP group from the CLI, you can use the **snmp-server group** global configuration command.

## Creating an SNMP User

Users are listed in the order in which they have been created. The maximum number of users that can be created is ten.

To define a user who can access the SNMP engine, follow these steps:

- Step 1** From the WAAS Central Manager menu, choose **Devices** > *device-name* (or **Device Groups** > *device-group-name*).
- Step 2** Choose **Configure** > **Monitoring** > **SNMP** > **User**. A list of SNMP users for the device or device group appears.
- Step 3** In the taskbar, click the **Create New SNMP User** icon. The Creating New SNMP User window appears. [Table 17-41](#) describes the fields in this window.

**Table 17-41** *SNMP User Settings*

| GUI Parameter            | Function                                                                                                                                                                                                                                                                                                                                                                                                                                                                                                                                                                     |
|--------------------------|------------------------------------------------------------------------------------------------------------------------------------------------------------------------------------------------------------------------------------------------------------------------------------------------------------------------------------------------------------------------------------------------------------------------------------------------------------------------------------------------------------------------------------------------------------------------------|
| Name                     | String representing the name of the user (32 characters maximum) who can access the device or device group. This is a required field.                                                                                                                                                                                                                                                                                                                                                                                                                                        |
| Group                    | Name of the group (64 characters maximum) to which the user belongs. This is a required field.                                                                                                                                                                                                                                                                                                                                                                                                                                                                               |
| Remote SNMP ID           | Globally unique identifier for a remote SNMP entity (10 to 64 characters). To send an SNMPv3 message to the WAE, at least one user with a remote SNMP ID must be configured on the WAE. The SNMP ID must be entered in octet string format. Only hexadecimal characters and the colon (:) are allowed in this field. If any colons appear in the entered string, they are removed when the page is submitted.                                                                                                                                                                |
| Authentication Algorithm | Authentication algorithm that ensures the integrity of SNMP packets during transmission. Choose one of the following three options from the drop-down list: <ul style="list-style-type: none"> <li>• <b>No-auth</b>—Requires no security mechanism to be turned on for SNMP packets.</li> <li>• <b>MD5</b>—Provides authentication based on the hash-based Message Authentication Code Message Digest 5 (HMAC-MD5) algorithm.</li> <li>• <b>SHA</b>—Provides authentication based on the hash-based Message Authentication Code Secure Hash (HMAC-SHA) algorithm.</li> </ul> |
| Authentication Password  | Alphanumeric string (256 characters maximum) that configures the user authentication (HMAC-MD5 or HMAC-SHA) password. The number of characters is adjusted to fit the display area if it exceeds the limit for display. The following special characters are not supported: space, backwards single quote (`), single quote ('), double quote ("), pipe ( ), or question mark (?).<br><br>This field is optional if the <b>no-auth</b> option is chosen for the authentication algorithm. Otherwise, this field must contain a value.                                        |
| Confirmation Password    | Authentication password for confirmation. The reentered password must be the same as the one entered in the previous field.                                                                                                                                                                                                                                                                                                                                                                                                                                                  |

Table 17-41 SNMP User Settings (continued)

| GUI Parameter         | Function                                                                                                                                                                                                                                                                                                                                                                                                                                                                                                              |
|-----------------------|-----------------------------------------------------------------------------------------------------------------------------------------------------------------------------------------------------------------------------------------------------------------------------------------------------------------------------------------------------------------------------------------------------------------------------------------------------------------------------------------------------------------------|
| Private Password      | Alphanumeric string (256 characters maximum) that configures the authentication (HMAC-MD5 or HMAC-SHA) parameters to enable the SNMP agent to receive packets from the SNMP host. The number of characters is adjusted to fit the display area if it exceeds the limit for display. The following special characters are not supported: space, backwards single quote (`), double quote ("), pipe ( ), or question mark (?).<br><br> |
|                       | <b>Note</b> For SNMPv3 users using WAAS Software Version 6.x and later, the private password must be a minimum of 8 alphanumeric characters and a maximum of 256 characters.                                                                                                                                                                                                                                                                                                                                          |
| Confirmation Password | Private password for confirmation. The reentered password must be the same as the one entered in the previous field.                                                                                                                                                                                                                                                                                                                                                                                                  |

- Step 4** In the appropriate fields, enter the username, the group to which the user belongs, the engine identity of the remote entity to which the user belongs, the authentication algorithm used to protect SNMP traffic from tampering, the user authentication parameters, and the authentication parameters for the packet.
- Step 5** Click **Submit**.

To create an SNMP user from the CLI, you can use the **snmp-server user** global configuration command.

Additionally, if you want to set up a monitor user to monitor the configured triggers, you can select it from the **Monitor User Settings** drop-down box.

Any SNMP V3 user can be configured as a Monitor User. All the SNMP users created with a group having V3 authentication other than v3-private are eligible to be a Monitor User. A monitor user cannot be deleted, while being in that role. Similarly the corresponding monitor user group also cannot be deleted when a monitor user is configured with that group.

To create a monitor user from the CLI, you can use the **snmp-server monitor user** global configuration command.

## Configuring SNMP Asset Tag Settings

To configure SNMP asset tag settings, which create values in the CISCO-ENTITY-ASSET-MIB, follow these steps:

- Step 1** From the WAAS Central Manager menu, choose **Devices > device-name** (or **Device Groups > device-group-name**).
- Step 2** Choose **Configure > Monitoring > SNMP > Asset Tag**. The SNMP Asset Tag Settings window appears.
- Step 3** In the Asset Tag Name field, enter a name for the asset tag.



**Step 4** Click **Submit**.

---

To configure SNMP asset tag settings from the CLI, you can use the **asset tag** global configuration command.

## Configuring SNMP Contact Settings

To configure SNMP contact settings, follow these steps:

- 
- Step 1** From the WAAS Central Manager menu, choose **Devices** > *device-name* (or **Device Groups** > *device-group-name*).
- Step 2** Choose **Configure** > **Monitoring** > **SNMP** > **Contact Information**. The SNMP Contact Settings window appears.
- Step 3** Enter a contact name and location in the provided fields.
- Step 4** Click **Submit**.
- 

To configure SNMP contact settings from the CLI, you can use the **snmp-server contact** global configuration command.

## Configuring SNMP Trap Source Settings

To configure the source interface from which SNMP traps are sent, follow these steps:

- 
- Step 1** From the WAAS Central Manager menu, choose **Devices** > *device-name*. (This setting is not supported from device groups.)
- Step 2** Choose **Configure** > **Monitoring** > **SNMP** > **Trap Source**. The SNMP Trap Source Settings window appears.
- Step 3** From the Trap Source drop-down list, choose the interface to be used as the trap source. From the available physical, standby, and port-channel interfaces, only those with IP addresses are shown in the list. For vWAAS devices, virtual interfaces with assigned IP addresses are shown in the list.



**Note** An interface assigned as a trap source cannot be removed until it is unassigned as a trap source.

---

**Step 4** Click **Submit**.

---

To configure SNMP trap source settings from the CLI, you can use the **snmp-server trap-source** global configuration command.





## Predefined Optimization Policy

---

The WAAS software includes over 200 predefined optimization policy rules that help your WAAS system classify and optimize some of the most common traffic on your network. [Table A-1](#) lists the predefined applications and class maps that WAAS will either optimize or pass through based on the policy rules that are provided with the system.

Before you create an optimization policy, we recommend that you review the predefined policy rules and modify them as appropriate. Often, you can more easily modify an existing policy rule than create a new one.

When reviewing [Table A-1](#), note the following information:

- The subheadings represent the application names, and the associated class maps are listed under these subheadings. For example, Authentication is a type of application and Kerberos is a class map for that application.
- Applications and class maps with the word (*monitored*) next to them are monitored by the WAAS Central Manager, which can monitor statistics for up to 25 applications and 25 class maps at a time. To view statistics for one of the unmonitored applications, use one of the following methods:
  - Use the WAAS CLI, which can display statistics for all applications and class maps on a WAAS device. For more information, see the *Cisco Wide Area Application Services Command Reference*.
  - Modify the application or class map settings so the WAAS Central Manager GUI displays statistics for the desired application or class map. For more information, see [Chapter 12, “Configuring Application Acceleration.”](#)
- WAAS Express devices have similar default policy rules but provide application acceleration only for HTTP, SSL, and SMB traffic. Where a different application accelerator is listed in [Table A-1](#), it is not part of the WAAS Action for a WAAS Express device.

The WAAS software uses the following optimization technologies based on the type of traffic that it encounters:

- TFO (transport flow optimization)—A collection of optimization technologies such as automatic windows scaling, increased buffering, and selective acknowledgment that optimize all TCP traffic over your network.
- DRE (data redundancy elimination)—A compression technology that reduces the size of transmitted data by removing redundant information before sending the shortened data stream over the WAN. DRE operates on significantly larger streams and maintains a much larger compression history than LZ compression. DRE can use bidirectional, unidirectional, or adaptive caching. Unless noted in [Table A-1](#), DRE caching is bidirectional.
- LZ (compression)—Another compression technology that operates on smaller data streams and keeps limited compression history compared to DRE.

- Application accelerator—A collection of individual application accelerators for the following traffic types: EPM, HTTP, ICA, MAPI, NFS, SSL, and streaming video. (Some application accelerators are not available on WAAS Express devices.)

**Table A-1** Predefined Traffic Policy Rules

| Application/Class Map                   | WAAS Action                   | Destination Ports                          |
|-----------------------------------------|-------------------------------|--------------------------------------------|
| class-default ( <i>monitored</i> )      | LZ+TFO+<br>DRE-adaptive       | All ports not included in other class maps |
| <b>Authentication</b>                   |                               |                                            |
| apple-sasl                              | Passthrough                   | 3659                                       |
| auth                                    | Passthrough                   | 113                                        |
| Kerberos                                | Passthrough                   | 88, 888, 2053                              |
| kerberos-adm ( <i>monitored</i> )       | Passthrough                   | 749                                        |
| klogin                                  | Passthrough                   | 543                                        |
| kpasswd                                 | Passthrough                   | 464                                        |
| kshell                                  | Passthrough                   | 544                                        |
| TACACS                                  | Passthrough                   | 49                                         |
| tell                                    | Passthrough                   | 754                                        |
| <b>Backup</b> ( <i>monitored</i> )      |                               |                                            |
| Amanda                                  | TFO                           | 10080                                      |
| backup-express                          | TFO                           | 6123                                       |
| CommVault                               | TFO                           | 8400–8403                                  |
| connected                               | TFO                           | 16384                                      |
| IBM-TSM                                 | LZ+TFO+<br>DRE-unidirectional | 1500-1502                                  |
| Legato-NetWorker                        | TFO                           | 7937, 7938, 7939                           |
| Legato-RepliStor                        | TFO                           | 7144, 7145                                 |
| Veritas-BackupExec ( <i>monitored</i> ) | TFO                           | 1125, 3527, 6101, 6102, 6106               |
| Veritas-NetBackup                       | TFO                           | 13720, 13721, 13782, 13785                 |
| <b>CAD</b>                              |                               |                                            |
| PDMWorks                                | LZ+TFO+DRE                    | 30000, 40000                               |
| <b>Call-Management</b>                  |                               |                                            |
| Cisco-CallManager                       | Passthrough                   | 2443, 2748                                 |
| cisco-q931-backhaul                     | Passthrough                   | 2428                                       |
| cisco-sccp                              | Passthrough                   | 2000–2002                                  |
| h323hostcall                            | Passthrough                   | 1720                                       |
| h323hostcallsc                          | Passthrough                   | 1300                                       |
| mgcp-callagent                          | Passthrough                   | 2727                                       |
| mgcp-gateway                            | Passthrough                   | 2427                                       |
| sip                                     | Passthrough                   | 5060                                       |

Table A-1 Predefined Traffic Policy Rules (continued)

| Application/Class Map                         | WAAS Action               | Destination Ports                                                              |
|-----------------------------------------------|---------------------------|--------------------------------------------------------------------------------|
| sip-tls                                       | Passthrough               | 5061                                                                           |
| VoIP-Control                                  | Passthrough               | 1718, 1719, 11000–11999                                                        |
| <b>Citrix</b>                                 |                           |                                                                                |
| Citrix ( <i>monitored</i> )                   | TFO+ ICA accelerator      | 1494, 2598, or a dynamic port associated with the <b>citrix</b> protocol match |
| <b>Conferencing</b>                           |                           |                                                                                |
| cuseeme                                       | Passthrough               | 7640, 7642, 7648, 7649                                                         |
| ezMeeting                                     | Passthrough               | 10101–10103, 26260, 26261                                                      |
| MS-NetMeeting ( <i>monitored</i> )            | Passthrough               | 522, 1503, 1731                                                                |
| proshare                                      | Passthrough               | 5713–5717                                                                      |
| PSOM-MTLS                                     | Passthrough               | 8057                                                                           |
| VocalTec                                      | Passthrough               | 1490, 6670, 25793, 22555                                                       |
| <b>Console</b>                                |                           |                                                                                |
| cmd                                           | Passthrough               | 514                                                                            |
| exec                                          | Passthrough               | 512                                                                            |
| login                                         | Passthrough               | 513                                                                            |
| sshell                                        | Passthrough               | 614                                                                            |
| Telnet                                        | Passthrough               | 23, 107                                                                        |
| Telnets                                       | Passthrough               | 992                                                                            |
| <b>Content-Management (<i>monitored</i>)</b>  |                           |                                                                                |
| dmdocbroker                                   | LZ+TFO+DRE                | 1489                                                                           |
| Filenet                                       | LZ+TFO+DRE                | 32768–32774                                                                    |
| <b>Directory-Services (<i>monitored</i>)</b>  |                           |                                                                                |
| LDAP                                          | LZ+TFO+DRE-unidirectional | 389, 8404                                                                      |
| ldaps                                         | Passthrough               | 636                                                                            |
| msft-gc                                       | LZ+TFO+DRE-unidirectional | 3268                                                                           |
| msft-gc-ssl                                   | Passthrough               | 3269                                                                           |
| <b>Email-and-Messaging (<i>monitored</i>)</b> |                           |                                                                                |
| ccmail                                        | LZ+TFO+DRE                | 3264                                                                           |
| groupwise                                     | LZ+TFO+DRE                | 1677, 2800, 3800, 7100, 7101, 7180, 7181, 7205, 9850                           |
| imap                                          | LZ+TFO+DRE                | 143                                                                            |
| imap3                                         | LZ+TFO+DRE                | 220                                                                            |
| imaps                                         | TFO                       | 993                                                                            |
| iso-tsap                                      | LZ+TFO+DRE                | 102                                                                            |

Table A-1 Predefined Traffic Policy Rules (continued)

| Application/Class Map                      | WAAS Action                     | Destination Ports                                                                                                                                         |
|--------------------------------------------|---------------------------------|-----------------------------------------------------------------------------------------------------------------------------------------------------------|
| lotusnote                                  | LZ+TFO+DRE                      | 1352                                                                                                                                                      |
| MAPI <sup>1</sup> (monitored)              | LZ+TFO+DRE+<br>MAPI accelerator | UUID:a4f1db00-ca47-1067-b31f-00dd0106<br>62da                                                                                                             |
| MDaemon                                    | LZ+TFO+DRE                      | 3000, 3001                                                                                                                                                |
| MS-Exchange-Directory-NSPI <sup>1</sup>    | Passthrough                     | UUID:f5cc5a18-4264-101a-8c59-08002b2f<br>8426                                                                                                             |
| MS-Exchange-Directory-RFR <sup>1</sup>     | Passthrough                     | UUID:1544f5e0-613c-11d1-93df-00c04fd7<br>bd09                                                                                                             |
| NNTP (monitored)                           | LZ+TFO+DRE                      | 119                                                                                                                                                       |
| nntps (monitored)                          | TFO                             | 563                                                                                                                                                       |
| openmail                                   | LZ+TFO+DRE                      | 5755, 5757, 5766, 5767, 5768, 5729                                                                                                                        |
| pcmail-srv                                 | LZ+TFO+DRE                      | 158                                                                                                                                                       |
| pop3                                       | LZ+TFO+DRE                      | 110                                                                                                                                                       |
| pop3s                                      | LZ+TFO+DRE                      | 995                                                                                                                                                       |
| QMTP                                       | TFO                             | 209                                                                                                                                                       |
| smtp (monitored)                           | LZ+TFO+DRE                      | 25                                                                                                                                                        |
| smtps                                      | TFO                             | 465                                                                                                                                                       |
| <b>Enterprise-Applications (monitored)</b> |                                 |                                                                                                                                                           |
| MS-GROOVE                                  | TFO                             | 2492                                                                                                                                                      |
| SAP (monitored)                            | LZ+TFO+DRE                      | 3200–3204, 3206–3219, 3221–3224,<br>3226–3259, 3261–3263, 3265–3267,<br>3270–3282, 3284–3305, 3307–3351,<br>3353–3388, 3390–3399, 3600–3658,<br>3662–3699 |
| Siebel                                     | LZ+TFO+DRE                      | 2320, 2321, 8448                                                                                                                                          |
| <b>File-System (monitored)</b>             |                                 |                                                                                                                                                           |
| afpovertcp                                 | LZ+TFO+DRE                      | 548                                                                                                                                                       |
| afs3                                       | LZ+TFO+DRE                      | 7000–7009                                                                                                                                                 |
| ncp                                        | LZ+TFO+DRE                      | 524                                                                                                                                                       |
| NFS                                        | LZ+TFO+DRE+<br>NFS accelerator  | 2049                                                                                                                                                      |
| sunrpc                                     | Passthrough                     | 111                                                                                                                                                       |
| <b>File-Transfer (monitored)</b>           |                                 |                                                                                                                                                           |
| BFTP                                       | LZ+TFO+DRE                      | 152                                                                                                                                                       |
| ftp (monitored)                            | Passthrough                     | 21                                                                                                                                                        |
| ftp-data <sup>2</sup>                      | LZ+TFO+DRE                      | 20 (source port)                                                                                                                                          |
| ftps                                       | TFO                             | 990                                                                                                                                                       |
| ftps-data <sup>2</sup>                     | Passthrough                     | 989 (source port)                                                                                                                                         |

Table A-1 Predefined Traffic Policy Rules (continued)

| Application/Class Map         | WAAS Action             | Destination Ports                                                                                                                                                                                                                        |
|-------------------------------|-------------------------|------------------------------------------------------------------------------------------------------------------------------------------------------------------------------------------------------------------------------------------|
| sftp                          | LZ+TFO+DRE              | 115                                                                                                                                                                                                                                      |
| TFTP                          | LZ+TFO+DRE              | 69                                                                                                                                                                                                                                       |
| TFTPS                         | TFO                     | 3713                                                                                                                                                                                                                                     |
| <b>Instant Messaging</b>      |                         |                                                                                                                                                                                                                                          |
| AOL                           | Passthrough             | 5190–5193                                                                                                                                                                                                                                |
| Apple-iChat                   | Passthrough             | 5297, 5298                                                                                                                                                                                                                               |
| ircs                          | Passthrough             | 994                                                                                                                                                                                                                                      |
| ircu                          | Passthrough             | 531, 6660–6665, 6667–6669                                                                                                                                                                                                                |
| msnp                          | Passthrough             | 1863, 6891–6900                                                                                                                                                                                                                          |
| sametime                      | Passthrough             | 1533                                                                                                                                                                                                                                     |
| talk                          | Passthrough             | 517                                                                                                                                                                                                                                      |
| xmpp-client                   | Passthrough             | 5222                                                                                                                                                                                                                                     |
| xmpp-server                   | Passthrough             | 5269                                                                                                                                                                                                                                     |
| Yahoo-Messenger               | Passthrough             | 5000, 5001, 5050, 5100                                                                                                                                                                                                                   |
| <b>Name Services</b>          |                         |                                                                                                                                                                                                                                          |
| DNS                           | Passthrough             | 53                                                                                                                                                                                                                                       |
| isns                          | Passthrough             | 3205                                                                                                                                                                                                                                     |
| nameserver                    | Passthrough             | 42                                                                                                                                                                                                                                       |
| netbios                       | Passthrough             | 137                                                                                                                                                                                                                                      |
| svrloc                        | Passthrough             | 427                                                                                                                                                                                                                                      |
| WINS ( <i>monitored</i> )     | Passthrough             | 1512                                                                                                                                                                                                                                     |
| <b>Other</b>                  |                         |                                                                                                                                                                                                                                          |
| Basic-TCP-services            | Passthrough             | 1–19                                                                                                                                                                                                                                     |
| BGP                           | Passthrough             | 179                                                                                                                                                                                                                                      |
| corba-iiop-ssl                | Passthrough             | 684                                                                                                                                                                                                                                      |
| epmap ( <i>monitored</i> )    | TFO, EPM<br>accelerator | 135                                                                                                                                                                                                                                      |
| msmq                          | LZ+TFO+DRE              | 1801, 2101, 2103, 2105                                                                                                                                                                                                                   |
| NTP                           | Passthrough             | 123                                                                                                                                                                                                                                      |
| Other-Secure                  | Passthrough             | 261, 448, 695, 994, 2252, 2478, 2479, 2482,<br>2484, 2679, 2762, 2998, 3077, 3078, 3183,<br>3191, 3220, 3410, 3424, 3471, 3496, 3509,<br>3529, 3539, 3660, 3661, 3747, 3864, 3885,<br>3896, 3897, 3995, 4031, 5007, 7674, 9802,<br>12109 |
| ssc-agent                     | LZ+TFO+DRE              | 2847, 2848, 2967, 2968, 38037, 38292                                                                                                                                                                                                     |
| Unclassified                  | LZ+TFO+DRE              |                                                                                                                                                                                                                                          |
| <b>P2P (<i>monitored</i>)</b> |                         |                                                                                                                                                                                                                                          |

**Table A-1** Predefined Traffic Policy Rules (continued)

| <b>Application/Class Map</b>      | <b>WAAS Action</b>            | <b>Destination Ports</b>           |
|-----------------------------------|-------------------------------|------------------------------------|
| BitTorrent                        | Passthrough                   | 6881–6889, 6969                    |
| eDonkey                           | Passthrough                   | 4661, 4662                         |
| Gnutella                          | Passthrough                   | 5634, 6346–6349, 6355              |
| Grouper                           | Passthrough                   | 8038                               |
| HotLine                           | Passthrough                   | 5500–5503                          |
| Kazaa                             | Passthrough                   | 1214                               |
| Laplink-ShareDirect               | Passthrough                   | 2705                               |
| Napster                           | Passthrough                   | 6666, 6677, 6688, 6700, 7777, 8875 |
| Qnext                             | Passthrough                   | 44, 5555                           |
| SoulSeek                          | Passthrough                   | 2234, 5534                         |
| WASTE                             | Passthrough                   | 1337                               |
| WinMX                             | Passthrough                   | 6699                               |
| <b>Printing (monitored)</b>       |                               |                                    |
| hp-pdl-datastr                    | LZ+TFO+DRE                    | 9100                               |
| IPP                               | LZ+TFO+DRE                    | 631                                |
| printer                           | LZ+TFO+DRE                    | 515                                |
| print-srv                         | LZ+TFO+DRE                    | 170                                |
| xprint-server                     | LZ+TFO+DRE                    | 8100                               |
| <b>Remote-Desktop (monitored)</b> |                               |                                    |
| Altiris-CarbonCopy                | Passthrough                   | 1680                               |
| citrixadmin                       | LZ+TFO+<br>DRE-unidirectional | 2513                               |
| citrixima                         | LZ+TFO+<br>DRE-unidirectional | 2512                               |
| citriximaclient (monitored)       | LZ+TFO+DRE                    | 2598                               |
| ControlIT                         | TFO                           | 799                                |
| Danware-NetOp                     | TFO                           | 6502                               |
| ica (monitored)                   | LZ+TFO+DRE                    | 1494                               |
| laplink                           | LZ+TFO+<br>DRE-unidirectional | 1547                               |
| Laplink-surfup-HTTPS              | TFO                           | 1184                               |
| ms-wbt-server (monitored)         | TFO                           | 3389                               |
| net-assistant                     | Passthrough                   | 3283                               |
| netrjs-3                          | TFO                           | 73                                 |
| pcanywheredata                    | TFO                           | 5631, 5632, 65301                  |
| radmin-port                       | TFO                           | 4899                               |
| Remote-Anything (monitored)       | TFO                           | 3999, 4000                         |



**Table A-1** Predefined Traffic Policy Rules (continued)

| Application/Class Map                 | WAAS Action                   | Destination Ports                         |
|---------------------------------------|-------------------------------|-------------------------------------------|
| timbuktu                              | TFO                           | 407                                       |
| timbuktu-srv                          | TFO                           | 1417–1420                                 |
| Vmware-VMConsole                      | TFO                           | 902                                       |
| VNC ( <i>monitored</i> )              | TFO                           | 5800–5809, 5900–5909                      |
| x11                                   | TFO                           | 6000–6063                                 |
| <b>Replication (<i>monitored</i>)</b> |                               |                                           |
| Double-Take                           | LZ+TFO+<br>DRE-unidirectional | 1100, 1105                                |
| EMC-Celerra-Replicator                | LZ+TFO+<br>DRE-adaptive       | 8888                                      |
| MS-AD-Replication <sup>1</sup>        | LZ+TFO+DRE                    | UUID:e3514235-4b06-11d1-ab04-00c04fc2dcd2 |
| ms-content-repl-srv                   | TFO                           | 507, 560                                  |
| MS-FRS <sup>1</sup>                   | LZ+TFO+DRE                    | UUID:f5cc59b4-4264-101a-8c59-08002b2f8426 |
| netapp-snapmirror                     | LZ+TFO+<br>DRE-adaptive       | 10565-10569                               |
| pcsync-http                           | LZ+TFO+DRE                    | 8444                                      |
| pcsync-https                          | TFO                           | 8443                                      |
| rrac                                  | TFO                           | 5678                                      |
| Rsync ( <i>monitored</i> )            | LZ+TFO+<br>DRE-unidirectional | 873                                       |
| <b>SQL (<i>monitored</i>)</b>         |                               |                                           |
| gds_db                                | LZ+TFO+DRE                    | 3050                                      |
| IBM-DB2                               | LZ+TFO+DRE                    | 523                                       |
| intersys-cache                        | LZ+TFO+DRE                    | 1972                                      |
| ms-olap4                              | TFO                           | 2383                                      |
| ms-sql-m                              | LZ+TFO+DRE                    | 1434                                      |
| MS-SQL-RPC <sup>1</sup>               | LZ+TFO+DRE                    | UUID:3f99b900-4d87-101b-99b7-aa0004007f07 |
| ms-sql-s ( <i>monitored</i> )         | LZ+TFO+DRE                    | 1433                                      |
| MySQL                                 | LZ+TFO+DRE                    | 3306                                      |
| Oracle                                | LZ+TFO+DRE                    | 66                                        |
| orasrv                                | LZ+TFO+DRE                    | 1521, 1525                                |
| Pervasive-SQL                         | LZ+TFO+DRE                    | 1583                                      |
| PostgreSQL                            | LZ+TFO+DRE                    | 5432                                      |
| sqlexec                               | LZ+TFO+DRE                    | 9088, 9089                                |
| sql-net                               | LZ+TFO+DRE                    | 150                                       |

**Table A-1** Predefined Traffic Policy Rules (continued)

| Application/Class Map                        | WAAS Action                                         | Destination Ports                         |
|----------------------------------------------|-----------------------------------------------------|-------------------------------------------|
| sqlserv                                      | LZ+TFO+DRE                                          | 118                                       |
| sqlsrv                                       | LZ+TFO+DRE                                          | 156                                       |
| ssql                                         | LZ+TFO+DRE                                          | 3352                                      |
| sybase-sqlany                                | LZ+TFO+DRE                                          | 1498, 2439, 2638, 3968                    |
| UniSQL                                       | LZ+TFO+DRE                                          | 1978, 1979                                |
| <b>SSH</b>                                   |                                                     |                                           |
| SSH ( <i>monitored</i> )                     | TFO                                                 | 22                                        |
| <b>SSL (<i>monitored</i>)</b>                |                                                     |                                           |
| HTTPS ( <i>monitored</i> )                   | TFO                                                 | 443                                       |
| <b>Storage (<i>monitored</i>)</b>            |                                                     |                                           |
| EMC-SRDFA-IP                                 | LZ+TFO+DRE                                          | 1748                                      |
| FCIP                                         | LZ+TFO                                              | 3225                                      |
| iFCP                                         | LZ+TFO+DRE                                          | 3420                                      |
| iscsi                                        | LZ+TFO+DRE                                          | 3260                                      |
| <b>Streaming (<i>monitored</i>)</b>          |                                                     |                                           |
| Liquid-Audio                                 | LZ+TFO+<br>DRE-unidirectional                       | 18888                                     |
| ms-streaming ( <i>monitored</i> )            | LZ+TFO+<br>DRE-unidirectional                       | 1755                                      |
| RTSP ( <i>monitored</i> )                    | LZ+TFO+<br>DRE-unidirectional<br>+Video accelerator | 554, 8554                                 |
| <b>Systems-Management (<i>monitored</i>)</b> |                                                     |                                           |
| BMC-Patrol                                   | Passthrough                                         | 6161, 6162, 6767, 6768, 8160, 8161, 10128 |
| eTrust-policy-Compliance                     | TFO                                                 | 1267                                      |
| flowmonitor                                  | LZ+TFO                                              | 7878                                      |
| HP-OpenView                                  | Passthrough                                         | 7426–7431, 7501, 7510                     |
| LANDesk                                      | LZ+TFO+DRE                                          | 9535, 9593–9595                           |
| NetIQ                                        | Passthrough                                         | 2220, 2735, 10113–10116                   |
| Netopia-netOctopus                           | Passthrough                                         | 1917, 1921                                |
| netviewdm                                    | Passthrough                                         | 729–731                                   |
| novadigm                                     | LZ+TFO+DRE                                          | 3460, 3461, 3464                          |
| novell-zen                                   | LZ+TFO+DRE                                          | 1761–1763, 2037, 2544, 8039               |
| objcall                                      | LZ+TFO+DRE                                          | 94, 627, 1965, 1580, 1581                 |
| WBEM                                         | Passthrough                                         | 5987–5990                                 |
| <b>Version-Management (<i>monitored</i>)</b> |                                                     |                                           |
| Clearcase                                    | LZ+TFO+DRE                                          | 371                                       |

**Table A-1** Predefined Traffic Policy Rules (continued)

| <b>Application/Class Map</b> | <b>WAAS Action</b>              | <b>Destination Ports</b>   |
|------------------------------|---------------------------------|----------------------------|
| cvspserver                   | LZ+TFO+DRE                      | 2401                       |
| <b>VPN</b>                   |                                 |                            |
| L2TP                         | TFO                             | 1701                       |
| OpenVPN                      | TFO                             | 1194                       |
| PPTP                         | TFO                             | 1723                       |
| <b>Web (monitored)</b>       |                                 |                            |
| HTTP (monitored)             | LZ+TFO+DRE+<br>HTTP accelerator | 80, 3128, 8000, 8080, 8088 |
| soap-http                    | LZ+TFO+<br>DRE-adaptive         | 7627                       |

1. These classifiers use the EPM service in WAAS to accelerate traffic. EPM-based applications do not have predefined ports so the application's UUID must be used to identify the traffic.
2. These classifiers identify the source port instead of the destination port.





# Transaction Log Format

You can use the transaction logging feature to log individual TCP transactions for a WAAS device. For information on configuring transaction logging, see the [Configuring Transaction Logging](#) in Chapter 16, “Troubleshooting Your WAAS Network.”

TFO transaction logs are kept on the local disk in the local/local1/logs/working.log directory.

There are several kinds of transaction log messages that have different templates, as follows

- Optimized Flow Start message:  
 Time\_Stamp :Conn\_ID :Src\_IP :Src\_Port :Dst\_IP :Dst\_Port :OT :Log\_type :Conn\_type :Peer\_ID  
 :App\_map\_name :App\_name :App\_classifier\_name :Flag\_directed\_mode :TFO\_cfgd\_policy  
 :TFO\_drvd\_policy :TFO\_peer\_policy :TFO\_neg\_policy :TFO\_applied\_policy :TFO\_reject\_reason  
 :AO\_cfgd\_policy :AO\_drvd\_policy :AO\_neg\_policy :AO\_reject\_reason :SSL\_reject\_reason :DSCP  
 :Link\_rtt
- Optimized Flow End Message:  
 Time\_Stamp :Conn\_ID :Src\_IP :Src\_Port :Dst\_IP :Dst\_Port :OT :Log\_type :Conn\_type  
 :AO\_neg\_policy :Original\_bytes\_read :Original\_bytes\_written :Optimized\_bytes\_read  
 :Optimized\_bytes\_written
- Pass Through Flow Message:  
 Time\_Stamp :Src\_IP :Src\_Port :Dst\_IP :Dst\_Port :BP :Bypass\_Reason :TFO\_cfgd\_policy  
 :TFO\_drvd\_policy :TFO\_peer\_policy :TFO\_reject\_reason :AO\_cfgd\_policy :AO\_drvd\_policy  
 :AO\_reject\_reason
- Optimized Flow TFO End Message:  
 Time\_Stamp :Conn\_ID :Src\_IP :Src\_Port :Dst\_IP :Dst\_Port :SODRE :END :Original\_bytes\_read  
 :Original\_bytes\_written :Optimized\_bytes\_read :Optimized\_bytes\_written :Conn\_close\_state
- System Restart Message:  
 Time\_Stamp :0 :0 :0 :0 :0 :RESTART

[Table B-1](#) describes the fields found in the transaction log messages.

**Table B-1** Transaction Log Field Descriptions

| Field            | Description                                               |
|------------------|-----------------------------------------------------------|
| Time_Stamp       | Time stamp indicating when the log message was generated. |
| Conn_ID          | A unique identifier for the connection.                   |
| Src_IP, Src_Port | Source IP address and port number for the connection.     |

**Table B-1 Transaction Log Field Descriptions (continued)**

| <b>Field</b>           | <b>Description</b>                                                                                                                                                                                                                                                                        |
|------------------------|-------------------------------------------------------------------------------------------------------------------------------------------------------------------------------------------------------------------------------------------------------------------------------------------|
| Dst_IP, Dst_Port       | Destination IP address and port number for connection.                                                                                                                                                                                                                                    |
| OT                     | Indicates an optimized connection.                                                                                                                                                                                                                                                        |
| BP                     | Indicates a pass-through connection.                                                                                                                                                                                                                                                      |
| SODRE                  | Indicates a log message generated by TFO.                                                                                                                                                                                                                                                 |
| Log_type               | START or END indicates the start or end of the flow.                                                                                                                                                                                                                                      |
| Conn_type              | Type of connection:<br>INTERNAL CLIENT—locally initiated connection from the WAE,<br>EXTERNAL CLIENT—WAE acting as branch device for the connection,<br>INTERNAL SERVER—locally terminated connection at the WAE,<br>EXTERNAL SERVER—WAE acting as data center device for the connection. |
| Peer_ID                | Device ID of the peer WAE.                                                                                                                                                                                                                                                                |
| App_map_name           | Map name.                                                                                                                                                                                                                                                                                 |
| App_classifier_name    | Classifier name.                                                                                                                                                                                                                                                                          |
| App_name               | Application name.                                                                                                                                                                                                                                                                         |
| TFO_cfgd_policy        | The TFO configured policy on the local device.                                                                                                                                                                                                                                            |
| TFO_drvd_policy        | The TFO derived policy on the local device based on the configured and dynamic conditions. This policy is used to negotiate with the peer WAE.                                                                                                                                            |
| TFO_peer_policy        | The TFO derived policy on the peer that is sent to the local device.                                                                                                                                                                                                                      |
| TFO_neg_policy         | The TFO negotiated policy, which is the lowest common policy between the derived and peer policies.                                                                                                                                                                                       |
| TFO_applied_policy     | The final policy applied to the connection. After the connection has been established, policy changes may be made to the connection based on the data on the connection, thus the applied policy can differ from the negotiated policy.                                                   |
| TFO_reject_reason      | Indicates the reason for a rejected connection. “None” indicates the reject reason is not set.                                                                                                                                                                                            |
| AO_cfgd_policy         | The application accelerator configured on the local device. This is derived from the accelerator configured in the corresponding policy.                                                                                                                                                  |
| AO_drvd_policy         | The application accelerator derived policy on the local device.                                                                                                                                                                                                                           |
| AO_neg_policy          | The application accelerator negotiated policy, which is the lowest common policy between the derived and peer policies.                                                                                                                                                                   |
| AO_reject_reason       | Indicates the reason an application accelerator rejected the connection. “None” indicates the reject reason is not set.                                                                                                                                                                   |
| SSL_reject_reason      | Indicates the reason the SSL accelerator rejected the connection. “None” indicates the reject reason is not set.                                                                                                                                                                          |
| DSCP                   | Differentiated Services Code Point value set on the outgoing connection.                                                                                                                                                                                                                  |
| Link_rtt               | Link round trip time in milliseconds.                                                                                                                                                                                                                                                     |
| Original_bytes_read    | Bytes read on the original side of the connection.                                                                                                                                                                                                                                        |
| Original_bytes_written | Bytes written on the original side of the connection.                                                                                                                                                                                                                                     |

**Table B-1 Transaction Log Field Descriptions (continued)**

| Field                   | Description                                                                      |
|-------------------------|----------------------------------------------------------------------------------|
| Optimized_bytes_read    | Bytes read on the optimized side of the connection.                              |
| Optimized_bytes_written | Bytes written on the optimized side of the connection.                           |
| RESTART                 | Indicates that the WAE was reloaded and the transaction log process was started. |

Here are some examples of transaction log messages:

### Fully Optimized on both sides (with SSL rejection)

```
Fri Jan 30 03:15:41 2009 :43 :2.57.223.130 :4808 :2.57.223.2 :443 :OT :START :EXTERNAL CLIENT
:00.14.5e.95.4c.85 :basic :SSL :HTTPS :F :(TFO) (TFO) (TFO) (TFO) (TFO) :<None> :(None) (None) (None) :<None>
:<Keepalive Timeout> :0 :0
Fri Jan 30 03:15:41 2009 :43 :2.57.223.130 :4808 :2.57.223.2 :443 :SODRE :END :0 :0 :0 :0 :0
Fri Jan 30 03:15:41 2009 :43 :2.57.223.130 :4808 :2.57.223.2 :443 :OT :END :EXTERNAL CLIENT :(None) :284 :806
:806 :28
```

### Fully Optimized on both sides

```
Mon Feb 2 14:31:21 2009 :16 :2.75.52.131 :4374 :2.75.52.3 :80 :OT :START :EXTERNAL CLIENT :00.14.5e.83.8c.cf
:basic :Web :HTTP :F :(DRE,LZ,TFO) (DRE,LZ,TFO) (DRE,LZ,TFO) (DRE,LZ,TFO) (DRE,LZ,TFO) :<None> :(HTTP) (HTTP)
(HTTP) :<None> :<None> :0 :0
Mon Feb 2 14:31:26 2009 :16 :2.75.52.131 :4374 :2.75.52.3 :80 :SODRE :END :370 :173 :299 :429 :0
Mon Feb 2 14:31:26 2009 :16 :2.75.52.131 :4374 :2.75.52.3 :80 :OT :END :EXTERNAL CLIENT :(HTTP) :0 :0 :299
:429
```

### Optimized with only DRE enabled

```
Mon Feb 2 14:48:31 2009 :27 :2.75.52.131 :4389 :2.75.52.2 :80 :OT :START :EXTERNAL CLIENT :00.14.5e.83.8c.cf
:basic :Web :HTTP :F :(DRE,TFO) (DRE,TFO) (DRE,LZ,TFO) (DRE,TFO) (DRE,TFO) :<None> :(HTTP) (HTTP) (HTTP)
:<None> :<None> :0 :0
Mon Feb 2 14:48:36 2009 :27 :2.75.52.131 :4389 :2.75.52.2 :80 :SODRE :END :246 :468 :636 :405 :0
Mon Feb 2 14:48:36 2009 :27 :2.75.52.131 :4389 :2.75.52.2 :80 :OT :END :EXTERNAL CLIENT :(HTTP) :0 :0 :636
:405
```

### Optimized with only LZ enabled

```
Mon Feb 2 14:39:12 2009 :20 :2.75.52.131 :4379 :2.75.52.3 :80 :OT :START :EXTERNAL CLIENT :00.14.5e.83.8c.cf
:basic :Web :HTTP :F :(LZ,TFO) (LZ,TFO) (DRE,LZ,TFO) (LZ,TFO) (LZ,TFO) :<None> :(HTTP) (HTTP) (HTTP) :<None>
:<None> :0 :0
Mon Feb 2 14:39:17 2009 :20 :2.75.52.131 :4379 :2.75.52.3 :80 :SODRE :END :370 :173 :219 :295 :0
Mon Feb 2 14:39:17 2009 :20 :2.75.52.131 :4379 :2.75.52.3 :80 :OT :END :EXTERNAL CLIENT :(HTTP) :0 :0 :219
:295
```

### Optimized with both DRE and LZ disabled

```
Mon Feb 2 14:49:36 2009 :28 :2.75.52.131 :4390 :2.75.52.2 :80 :OT :START :EXTERNAL CLIENT :00.14.5e.83.8c.cf
:basic :Web :HTTP :F :(TFO) (TFO) (DRE,LZ,TFO) (TFO) (TFO) :<None> :(HTTP) (HTTP) (HTTP) :<None> :<None> :0
:0
Mon Feb 2 14:49:41 2009 :28 :2.75.52.131 :4390 :2.75.52.2 :80 :OT :END :EXTERNAL CLIENT :(HTTP) :0 :0 :468
:246
```

### Pass-Through Connection

```
Thu Jul 24 03:09:34 2008 :2.75.52.130 :40027 :2.75.52.2 :80 :BP :GLB_CFG :(DRE,LZ,TFO) (None) (None) :<Global
Config> :(HTTP) (None) :<Global Config>
```

### System Restart

```
Sun Oct 25 17:46:32 2009 :0 :0 : 0 :0 :0 :RESTART
```





---

## Numerics

- 10 Gigabit Ethernet interfaces
  - modifying [6-7](#)

---

## A

- AAA accounting
  - configuring [7-34](#)
- AAA-based management systems [2-26, 7-2](#)
- acceleration
  - about [1-7, 13-1](#)
  - features [1-7](#)
  - TCP adaptive buffering settings [13-66](#)
  - TCP settings [13-64](#)
- accelerators
  - enabling [13-3](#)
- accelerator threshold [13-58](#)
- accounts
  - creating [8-4](#)
  - creation process [8-2](#)
  - deleting [8-6](#)
  - local CLI [8-2](#)
  - roles-based [8-2](#)
  - types [8-1](#)
  - viewing [8-8](#)
- ACL
  - interception [5-28](#)
  - See also* IP ACL
- action
  - full optimization (adaptive cache) [13-55](#)
  - full optimization (bidirectional cache) [13-55](#)
  - full optimization (unidirectional cache) [13-55](#)
  - passthrough [13-55](#)
  - TFO only [13-55](#)
  - TFO with DRE (Adaptive Cache) [13-55](#)
  - TFO with DRE (Bidirectional Cache) [13-55](#)
  - TFO with DRE (Unidirectional Cache) [13-55](#)
  - TFO with LZ compression [13-55](#)
  - types [13-55](#)
- activating devices [16-35](#)
- adaptive buffering, TFO [13-66](#)
- adding
  - charts [17-13](#)
- administrative login authentication and authorization
  - default [7-4](#)
  - for WAEs [7-2](#)
  - local database description [7-6](#)
  - overview of [7-1](#)
  - RADIUS overview [7-12](#)
  - TACACS+ overview [7-14](#)
  - Windows domain overview [7-16](#)
- administrative login authentication failover [7-27](#)
- alarm overload detection, enabling [10-23](#)
- alarm panel
  - system dashboard window [17-3](#)
- alarms
  - device reporting [17-4](#)
- alerts [17-5](#)
- application acceleration
  - about [1-7, 13-1](#)
  - enabling [13-3](#)
- application classifiers
  - creating [13-53](#)
  - match condition [13-57](#)
  - restoring [13-61](#)

- application definition
    - creating [13-52](#)
  - application list, viewing [13-59](#)
  - application policy
    - creating [13-53](#)
    - creation process [13-51](#)
    - position [13-62](#)
    - preparation tasks [13-51](#)
    - restoring defaults [13-61](#)
  - applications
    - monitoring [13-61, 17-2](#)
  - AppNav
    - adding and removing devices [4-43](#)
    - AppNav Cluster [4-2](#)
    - AppNav Controller [4-1](#)
    - AppNav Controller Group [4-2](#)
    - appnav-controller interception [5-57](#)
    - AppNav Controller Interface Modules [4-3](#)
    - class maps [4-5](#)
    - cluster settings [4-35](#)
    - cluster settings for WAAS node [4-42](#)
    - cluster wizard [4-15](#)
    - configuring [4-1, 4-11](#)
    - configuring class maps [4-22](#)
    - configuring policy rules [4-28](#)
    - connection statistics [4-51](#)
    - connection tracing [4-51](#)
    - controller settings [4-37](#)
    - deployment models [4-3](#)
    - interface wizard [4-20](#)
    - monitoring cluster [4-47](#)
    - policies [4-5](#)
    - policy [4-4](#)
    - service context [4-2](#)
    - WAAS Node [4-2](#)
    - WAAS Node Group [4-2](#)
    - WAAS node group settings [4-41](#)
    - WAAS node settings [4-40](#)
  - AppNav-XE
    - enabling WAAS service insertion on interfaces [6-17](#)
    - registration process [10-28](#)
    - reimporting a certificate to the Central Manager [10-34](#)
  - assigning
    - devices to a preposition directive [12-16](#)
    - devices to device groups [3-5](#)
    - devices to more than one device group [3-7](#)
  - audit trail logs
    - viewing [7-35, 17-62](#)
  - authentication
    - default feature values [7-4](#)
  - authentication databases, types of [7-2](#)
  - authentication servers
    - configuring [7-12, 7-14](#)
  - authorization
    - default feature values [7-4](#)
  - autodiscover [1-20](#)
  - autoregistration
    - DHCP server requirements [2-8](#)
- 
- ## B
- backing up
    - configuration files [11-6](#)
    - WAAS Central Manager [16-10](#)
    - WAE devices [16-12](#)
  - backup and restore
    - cms database [16-10](#)
  - banners
    - configuring [7-10](#)
  - BIC TCP [1-6](#)
  - BMC
    - enabling IPMI over LAN [10-26](#)
    - enabling IPMI SoL [10-27](#)
    - firmware update [10-25](#)
  - bootflags [16-22](#)
  - bridge group

- assigning physical interface [6-20](#)
- creating [6-19](#)
- bridge virtual interface
  - creating [6-20](#)
- browser support [2-10](#)

---

## C

CDP

- configuring [6-27](#)
- cdp enable command [5-41](#)
- cdp run command [5-40](#)
- Central Manager. *See* WAAS Central Manager
- certificate
  - reimporting [10-34](#)
- charts
  - adding [17-13](#)
  - customizing [17-10](#)
  - descriptions [17-14](#)
  - settings [17-14](#)
- Cisco.com
  - obtaining software files from [16-3](#)
- Cisco Discovery Protocol. *See* CDP
- Cisco Prime Network Single Sign-on configuration [7-32](#)
- classifier, creating [13-53](#)
- classifier report, viewing [13-60](#)
- clear statistics all command [7-26](#)
- clear statistics authentication command [7-26](#)
- clear statistics windows-domain command [7-26](#)
- CLI user
  - creating [8-4](#)
- clock
  - setting [10-5](#)
- clustering in inline mode [5-53](#)
- cms database
  - backup and restore procedure [16-10](#)
- cms database backup command [16-10](#)
- cms database restore command [16-11](#)

- coherency
  - age-based validation [12-4](#)
- compression, about [1-6](#)
- conditions
  - modifying or deleting from IP ACLs [9-6](#)
- configuring WAAS CM for single sign-on [7-33](#)
- congestion windows, about [6-24](#)
- connections
  - viewing TCP connections [17-40](#)
- Connections Statistics report [17-40](#)
- connection statistics, AppNav [4-51](#)
- connection tracing [4-51](#)
- controlled shutdown [16-36](#)
- copy disk ftp command [16-10](#)
- core WAE, about [1-9](#)
- corrupted system images
  - recovering from [16-19](#)
- CPU load threshold [13-59](#)
- creating
  - accounts [8-4](#)
  - application classifier [13-53](#)
  - application definition [13-52](#)
  - application policy [13-53](#)
  - local user [8-4](#)
  - match condition [13-57](#)
  - new software file [16-3](#)
  - preposition directive [12-11](#)
  - preposition schedule [12-17](#)
- current software version
  - determining [16-3](#)

---

## D

dashboard

- customizing [17-10](#)
- device [17-8](#)
- system [17-1](#)

database backup [16-10](#)

data coherency, about [12-3](#)

- data concurrency, about [12-5](#)
- data migration [2-27](#)
- data redundancy elimination, about [1-6](#)
- debug command [17-65](#)
- default status, restoring [16-12](#)
- deleting
  - accounts [8-6](#)
  - device groups [3-6](#)
  - locations [3-11](#)
  - roles [8-13](#)
  - software files [16-9](#)
  - user groups [8-20](#)
- device
  - alarms [17-4](#)
  - autodiscovery [1-20](#)
  - clock setting [10-5](#)
  - rebooting [16-35](#)
- Device Dashboard window [17-8](#)
- device groups
  - about [3-1](#)
  - adding and removing devices [3-5](#)
  - configuring [3-4](#)
  - creating [3-3](#)
  - creation process [3-2](#)
  - deleting [3-6](#)
  - enabling overlap [3-7](#)
  - force group settings [3-7](#)
  - list [3-6](#)
  - overriding settings [3-7](#)
  - setting configuration precedence [3-8](#)
- Device Home window. See Device Dashboard window
- device locations
  - about [3-10](#)
  - creating [3-10](#)
  - deleting [3-11](#)
- device logs, viewing [17-63](#)
- device registration information
  - recovering [16-23](#)
- devices
  - activating [16-35](#)
  - adding to device groups [3-5](#)
  - adding to multiple device groups [3-7](#)
  - impact of assigning to multiple groups [3-9](#)
  - overriding device group settings [3-8](#)
  - restarting [16-35](#)
  - topology [17-40](#)
  - viewing group assignments [3-6](#)
  - viewing information for [17-6, 17-36, 17-40](#)
- Devices window [17-6](#)
- DHCP
  - configuring interfaces for [6-14](#)
  - for autoregistration [2-8](#)
  - interface-level [2-9](#)
- DHCP server
  - requirements for autoregistration [2-8](#)
- diagnostic tests [17-64](#)
- Disabling NetFlow v9 [17-51](#)
- disabling WCCP flow redirection [5-17](#)
- disk-based software, missing
  - recovering from [16-22](#)
- disk encryption [16-31](#)
- disk handling
  - configuring error-handling methods [16-32](#)
  - configuring extended object cache [16-33](#)
- disks
  - monitoring [17-43](#)
- Disks report [17-43](#)
- DNS, configuring [6-27](#)
- domains
  - about [8-14](#)
  - adding entities [8-15](#)
  - assigning to user accounts [8-15](#)
  - assigning to user groups [8-19](#)
  - creating [8-14](#)
  - deleting [8-16](#)
  - modifying and deleting [8-16](#)
  - viewing [8-17](#)

downgrading [16-3](#)

DRE, about [1-6](#)

DRE settings

    configuring [13-7](#)

DSCP [13-56](#)

    global default [13-61](#)

dynamic shares

    creating for SMB accelerator [12-19](#)

---

## E

edge WAE, about [1-9](#)

egress methods

    configuring [5-30](#)

email server settings for reports [10-24](#)

enable command [7-15](#)

enabling

    optimization and accelerators [13-3](#)

    protocol chaining [13-49](#)

    SNMP [18-14](#)

    SNMP agent [18-13](#)

    traffic statistic collection [13-52](#)

    WCCP flow redirection [5-17](#)

encryption

    disk [16-31](#)

    enabling secure store [10-10](#)

entities

    adding to domains [8-15](#)

EPM accelerator

    enabling [13-3](#)

errors

    disk drives [16-32](#)

EtherChannel

    configuring [6-10](#)

Exec timeout

    configuring [7-10](#)

explicit congestion notification

    about [6-24](#)

extended object cache [16-33](#)

---

## F

failover, for administrative login authentication [7-27](#)

fast offline detection

    about [10-23](#)

    configuring [10-22](#)

file locking, about [12-5](#)

File Server Rename utility [11-13](#)

file servers

    supported [12-7](#)

file services [12-8](#)

    about [1-8](#)

    features [1-9](#)

    preparing for [12-7](#)

    SMB configuration process [12-19](#)

firewall, configuring for [6-29](#)

flash memory

    corrupted [16-19](#)

flow monitoring

    configuring [17-48](#)

force group settings [3-7](#)

full optimization (adaptive cache) action [13-55](#)

full optimization (bidirectional cache) action [13-55](#)

full optimization (unidirectional cache) action [13-55](#)

---

## G

generic GRE egress method [5-30](#)

generic routing encapsulation. *See* GRE encapsulation

Gigabit Ethernet interfaces

    modifying [6-7](#)

GRE encapsulation [5-14, 5-16](#)

GRE packet forwarding [5-16](#)

GRE tunnel, configuring on router [5-32](#)

groups. *See* user groups

---

**H**

- hardware clock [10-5](#)
- hardware devices supported [2-10](#)
- high bandwidth WAN link [2-7](#)
- HTTP accelerator
  - configuring [13-8](#)
  - enabling [13-3](#)
  - HTTPS settings [13-8](#)

---

**I**

- ICA accelerator
  - configuring [13-29](#)
  - configuring ICA over SSL [13-31](#)
- increased buffering [1-5](#)
- inline mode [5-43](#)
  - configuring IP address [5-52](#)
  - interface settings [5-47](#)
  - serial clustering [5-53](#)
  - VLAN configuration [5-53](#)
  - VLAN ID check [5-46](#)
- inline network adapter card [5-43](#)
- installing system software [16-12](#)
- intelligent message prediction [1-7](#)
- interception
  - appnav-controller [5-57](#)
  - inline [5-43](#)
  - policy-based routing [5-33](#)
- WCCP [5-11](#)
- interception ACL [5-28](#)
- interface
  - assigning to bridge group [6-20](#)
- interface-level DHCP
  - description [2-9](#)
- interface module inline mode [5-43](#)
- interfaces
  - configuring [6-1](#)
  - configuring virtual [6-14](#)
  - enabling AppNav-XE service insertion [6-17](#)
  - manually configuring for DHCP [6-14](#)
  - WAAS Express optimization [6-16](#)
- IP access control lists. *See* IP ACL
- IP ACL
  - adding conditions to [9-3](#)
  - applying to interface [9-6](#)
  - associating with application [9-6](#)
  - conditions, modifying or deleting [9-6](#)
  - configuration constraints [9-2](#)
  - creating new [9-3](#)
  - deleting [9-7](#)
  - on routers [2-25](#)
  - on WAEs [2-25](#)
  - overview [9-1](#)
- IP addresses
  - multiple, configuring on single interface [6-6](#)
  - static [2-9](#)
- IPMI over LAN
  - about [10-25](#)
  - enabling [10-26](#)
  - enabling SoL [10-27](#)
- IP routes
  - configuring [6-26](#)
- ip wccp command [5-10](#)
- ip wccp redirect-list command [5-10](#)
- ip web-cache redirect command [5-10](#)

---

**K**

- kernel debugger
  - enabling [17-63](#)

---

**L**

- Layer 2 redirection [5-16](#)
- LDAP server signing

- configuring on a Microsoft server [7-24](#)
  - configuring on a WAE [7-25](#)
  - disabling on a WAE [7-26](#)
  - overview of [7-24](#)
- licenses [10-3](#)
- line console carrier detection
  - configuring [7-11](#)
- load balancing [1-23, 5-12, 6-13](#)
- local CLI accounts, about [8-2](#)
- local user, creating [8-4](#)
- locations
  - about [3-10](#)
  - creating [3-10](#)
  - deleting [3-11](#)
- location tree
  - viewing [3-11](#)
- logging
  - configuring system logging [17-56](#)
  - message priority levels [17-58](#)
  - transaction log format [B-1](#)
  - transaction logging [17-59](#)
  - viewing audit trail log [17-62](#)
  - viewing device logs [17-63](#)
  - viewing system messages [17-62](#)
- login access
  - controlling [7-7](#)
- login authentication
  - about [2-25, 7-1](#)
- logs
  - severity levels in the WAE Device Manager [11-22](#)
  - viewing in the WAE Device Manager [11-21](#)
- lost administrator passwords
  - recovering [16-21](#)
- LZ compression, about [1-6](#)

---

## M

- management IP address [10-2](#)
- MAPI accelerator

- configuring [13-11](#)
  - enabling [13-3](#)
- match condition, creating [13-57](#)
- maximum segment size [13-65](#)
- message logs
  - viewing [17-62](#)
- message of the day settings
  - configuring [7-10](#)
- Message Signing Server Database [12-19](#)
- MIBs
  - supported [18-4](#)
- MIB traps
  - configuring using the WAE Device Manager [11-8](#)
- migration, data [2-27](#)
- missing disk-based software
  - recovering from [16-22](#)
- monitoring
  - applications [13-61, 17-2](#)
  - chart descriptions [17-14](#)
  - chart settings [17-14](#)
  - creating custom reports [17-44](#)
  - disk information [17-43](#)
  - flows with NetQoS [17-48](#)
  - predefined reports [17-35](#)
  - resource utilization [17-42](#)
  - system status [17-5](#)
  - using the WAE Device Manager [11-17](#)
  - with SNMP [18-1](#)
- multiple IP addresses
  - configuring on single interfaces [6-6](#)

---

## N

- NAS appliances [1-21](#)
- NAT address [10-2](#)
- NAT configuration [10-2](#)
- NetBIOS [10-2](#)
- NetFlow v9 [17-50](#)
- NetQoS monitoring [17-48](#)

network  
     viewing information for [17-1](#)  
 Network Time Protocol. *See* NTP  
 network traffic analyzer tool [17-65](#)  
 NFS accelerator  
     enabling [13-3](#)  
 notification settings  
     for alerts [11-9](#)  
     for reports [10-24](#)  
 NTP, configuring [10-5](#)

---

## O

obtaining software files [16-3](#)  
 operation prediction and batching [1-7](#)  
 optimization  
     configuring on WAAS Express interfaces [6-16](#)  
     enabling global features [13-3](#)

---

## P

packet forwarding method [5-14](#)  
     Layer 2 redirection [5-16](#)  
     Layer 3 GRE [5-16](#)  
 packet return [5-15](#)  
 passthrough action [13-55](#)  
 passwords  
     changing account [8-6, 8-7](#)  
     recovering administrator [16-21](#)  
 PBR, about [1-22](#)  
 policy-based routing  
     about [1-22](#)  
     configuration of interception [5-33](#)  
     overview of [2-20](#)  
     verifying next-hop availability [5-40](#)  
 policy report, viewing [13-60](#)  
 port channel interfaces  
     assigning physical interfaces [6-12](#)

    configuring [6-10](#)  
     load balancing [6-13](#)  
 ports  
     139 [2-6](#)  
         bypassing [2-7](#)  
     445 [2-6](#)  
 position, application policy [13-62](#)  
 power failure [16-19](#)  
 preposition  
     about [12-5](#)  
     checking status of [12-18](#)  
     creating directive [12-11](#)  
     scheduling [12-17](#)  
     viewing in the WAE Device Manager [11-14](#)  
 print accelerator [1-9](#)  
 print services  
     about [1-9](#)  
 priority levels [17-58](#)

---

## R

RADIUS  
     authentication overview [7-12](#)  
     configuring server [7-12](#)  
     database [7-2](#)  
     default configuration [7-4](#)  
 RAID [1-23](#)  
 RCP services, enabling [10-4](#)  
 rebooting devices [16-35](#)  
 receive buffer size [13-65](#)  
 recovering  
     device registration information [16-23](#)  
     from missing disk-based software [16-22](#)  
     lost administrator passwords [16-21](#)  
     system software [16-19](#)  
 redirection methods [5-1](#)  
 registering  
     AppNav-XE device [10-28](#)  
     WAAS Express device [10-28](#)



- WAEs in the WAE Device Manager [11-6](#)
  - reinstalling system software [16-12](#)
  - remote login
    - controlling access [7-7](#)
  - reports
    - configuring email server settings [10-24](#)
    - Connections Statistics [17-40](#)
    - creating custom [17-44](#)
    - customizing [17-10](#)
    - editing [17-46](#)
    - managing [17-44](#)
    - predefined [17-35](#)
    - resource utilization [17-42](#)
    - scheduling [17-46](#)
    - Topology [17-40](#)
    - viewing custom [17-46](#)
  - request redirection methods [5-1](#)
  - rescue system image [16-19](#)
  - resource utilization report [17-42](#)
  - restarting devices [16-35](#)
  - restoring
    - application classifiers [13-61](#)
    - application policies [13-61](#)
    - configuration files [11-7](#)
    - WAAS Central Manager [16-10](#)
    - WAE devices [16-12](#)
    - WAE to default condition [16-12](#)
  - retransmit time multiplier
    - about [6-24](#)
  - roles
    - about [8-9](#)
    - assigning to user accounts [8-12](#)
    - assigning to user groups [8-18](#)
    - creating and managing [8-10](#)
    - deleting [8-13](#)
    - modifying and deleting [8-13](#)
    - read-only access to services [8-10](#)
    - viewing [8-13](#)
    - viewing settings [8-13](#)
  - roles-based accounts
    - about [8-2, 8-3](#)
  - router
    - configuring WCCP transparent redirection on [5-6](#)
- 
- ## S
- SACK, about [1-5](#)
  - scheduling
    - preposition [12-17](#)
    - reports [17-46](#)
  - secure shell
    - configuring [7-7](#)
    - host keys [7-8](#)
  - secure store
    - changing key and password [10-15](#)
    - configuring [10-10](#)
    - disabling [10-17](#)
    - enabling on Central Manager [10-12](#)
    - enabling on standby Central Manager [10-13](#)
    - enabling on WAE [10-13](#)
  - security
    - disk encryption [16-31](#)
    - enabling secure store [10-10](#)
  - selective acknowledgement [1-5](#)
  - send buffer size [13-65](#)
  - send TCP keepalive [13-64](#)
  - serial clustering in inline mode [5-53](#)
  - service context, AppNav [4-2](#)
  - service password
    - configuring [5-10](#)
  - set ip next-hop verify-availability command [5-41](#)
  - shadow copy for shared folders [12-6](#)
  - show cdp neighbors command [5-40](#)
  - show command utility
    - for troubleshooting [17-66](#)
  - show version command [16-21](#)
  - shutting down WCCP [5-27](#)
  - Simple Network Management Protocol. *See* SNMP

- site and network planning [2-4](#)
  - SMB accelerator
    - configuring [12-19](#)
  - SNMP [1-24](#)
    - asset tag setting [18-25](#)
    - community settings [18-20](#)
    - configuration process [18-13](#)
    - configuring using the WAE Device Manager [11-8](#)
    - contact settings [18-25](#)
    - defining custom traps [18-17](#)
    - enabling [18-14](#)
    - enabling SNMP agent [18-13](#)
    - enabling traps [18-15](#)
    - group settings [18-22](#)
    - host settings [18-19](#)
    - manager
      - creating [18-3](#)
      - monitoring with [18-1](#)
      - preparation [18-14](#)
      - security models and security levels [18-4](#)
      - supported MIBs [18-4](#)
      - trap source settings [18-25](#)
      - user settings [18-23](#)
      - versions supported [18-3](#)
      - view settings [18-21](#)
  - software
    - recovering [16-19](#)
  - software clock [10-5](#)
  - software files
    - obtaining from Cisco.com [16-3](#)
  - software licenses [10-3](#)
  - software recovery [16-12](#)
  - software upgrades [16-3](#)
    - for multiple devices [16-7](#)
    - process [16-1](#)
  - software version
    - determining [16-3](#)
  - SSL
    - configuring [13-31](#)
  - standby Central Manager
    - switching to primary [16-29](#)
  - standby groups
    - of interfaces [6-3](#)
  - standby interfaces
    - assigning physical interfaces [6-6](#)
    - configuring [6-3](#)
    - primary interface [6-6](#)
  - starting WAE components [11-5](#)
  - static IP addresses [2-9](#)
  - static IP routes
    - configuring [6-26](#)
  - statistics, collecting [13-52](#)
  - stopping WAE components [11-5](#)
  - system configuration settings [10-17](#)
  - system dashboard
    - viewing system-wide information [17-1](#)
  - system event logging
    - configuring [17-56](#)
    - message priority levels [17-58](#)
    - viewing log [17-62](#)
  - system image
    - recovering [16-19](#)
  - system message log
    - using [17-56](#)
    - viewing [17-62](#)
  - system software
    - recovering [16-19](#)
  - system status
    - monitoring [17-5](#)
- 
- T**
- TACACS+
    - authentication and authorization, overview of [7-14](#)
    - database [7-2](#)
    - default configuration [7-4](#)
    - enable password attribute [7-15](#)
  - TACACS+ server

- configuring [7-14](#)
  - taskbar icons [1-16](#)
  - TCP
    - congestion windows [6-24](#)
    - explicit congestion notification [6-24](#)
    - parameter settings [6-22](#)
    - retransmit timer [6-24](#)
    - slow start [6-25](#)
    - viewing connections [17-40](#)
  - tcpdump command [17-65](#)
  - TCP initial window size, about [1-5](#)
  - TCP promiscuous mode service
    - overview of [2-24](#)
  - Telnet services
    - enabling [7-9](#)
  - Ten Gigabit Ethernet interfaces
    - modifying [6-7](#)
  - test command for troubleshooting [17-65](#)
  - tethered command [17-65](#)
  - TFO
    - about [1-4](#)
  - TFO adaptive buffering [13-66](#)
  - TFO and LZ compression action [13-55](#)
  - TFO features [1-4](#)
    - BIC TCP [1-6](#)
    - compression [1-6](#)
    - increased buffering [1-5](#)
    - selective acknowledgement [1-5](#)
    - TCP initial window size maximization [1-5](#)
    - Windows scaling [1-5](#)
  - TFO only action [13-55](#)
  - TFO with DRE (Adaptive Cache) action [13-55](#)
  - TFO with DRE (Bidirectional Cache) action [13-55](#)
  - TFO with DRE (Unidirectional Cache) action [13-55](#)
  - time zones
    - location abbreviations [10-7](#)
    - parameter settings for [10-5](#)
  - Topology report [17-40](#)
  - traceroute [17-66](#)
  - track command [5-42](#)
  - traffic statistics collection, enabling [13-52](#)
  - traffic statistics report [17-2](#)
    - chart descriptions [17-14](#)
  - transaction logging [17-59](#)
    - configuring [17-59](#)
    - log format [B-1](#)
  - transparent redirection, configuring on a router [5-6](#)
  - traps
    - defining SNMP [18-17](#)
    - enabling [18-15](#)
  - triggers
    - defining SNMP [18-17](#)
  - troubleshooting
    - CLI commands [17-65](#)
    - using show command utility [17-66](#)
    - with Central Manager diagnostic tests [17-64](#)
    - with TCPdump [17-65](#)
    - with Tethered [17-65](#)
    - with WAAS TCP Traceroute [17-66](#)
  - Troubleshooting Devices window [17-5](#)
- 
- ## U
- Unicode support [2-10](#)
  - upgrading
    - device groups [16-7](#)
    - process [16-1](#)
    - WAAS Central Manager device [16-5](#)
  - user accounts
    - adding domain entities [8-15](#)
    - assigning to domains [8-15](#)
    - audit trail logs
      - viewing [7-35, 17-62](#)
    - changing passwords [8-6, 8-7](#)
    - creating [8-4](#)
    - creation process [8-2](#)
    - deleting [8-6](#)
    - deleting domains [8-16](#)

- domains [8-14](#)
- managing [8-7](#)
- modifying and deleting [8-6](#)
- roles
  - assigning to [8-12](#)
  - creating [8-10](#)
  - modifying and deleting [8-13](#)
  - viewing [8-13](#)
- viewing [8-8](#)
- viewing domains [8-17](#)
- user authentication. *See* login authentication
- user groups
  - about [8-17](#)
  - assigning roles to [8-18](#)
  - assigning to domains [8-19](#)
  - creating [8-18](#)
  - deleting [8-20](#)
  - viewing [8-20](#)
- UTC offsets [10-8](#)
- See also* GMT offsets

---

## V

- version of software [16-3](#)
- video accelerator
  - configuring [13-23](#)
  - enabling [13-3](#)
- viewing
  - application list [13-59](#)
  - classifier report [13-60](#)
  - logs in the WAE device manager [11-21](#)
  - policy report [13-60](#)
  - role settings [8-13](#)
- virtual interfaces
  - modifying [6-14](#)
- VLAN ID check [5-46](#)
- VLAN support [5-45](#)

- vWAAS
  - virtual interface configuration [6-14](#)

---

## W

- WAAS
  - benefits [1-20](#)
  - interfaces [1-10](#)
- WAAS Central Manager
  - backing up [16-10](#)
  - restoring [16-10](#)
  - upgrading [16-5](#)
- WAAS Central Manager GUI
  - about [1-10](#)
  - accessing [1-11](#)
  - components [1-12](#)
  - taskbar icons [1-16](#)
- WAAS CLI, about [1-19](#)
- WAAS Express
  - configuring a device certificate [10-32](#)
  - configuring an NTP server [10-34](#)
  - configuring a user [10-30](#)
  - configuring optimization on interfaces [6-16](#)
  - enabling HTTP secure server [10-33](#)
  - importing Central Manager certificate [10-31](#)
  - installing a license [10-33](#)
  - registering with the Central Manager [10-34](#)
  - registration process [10-28](#)
  - reimporting a certificate to the Central Manager [10-34](#)
- WAAS interfaces
  - CLI [1-19](#)
  - WAAS Central Manager GUI [1-10](#)
  - WAE Device Manager GUI [1-18](#)
- WAAS networks
  - and IOP interoperability [2-11](#)
  - network planning for [2-1](#)

- traffic redirection methods [2-18](#)
- WAAS services, about [1-4](#)
- WAAS TCP Traceroute [17-66](#)
- WAE Device Manager
  - about [1-18, 11-1](#)
  - Configuration option [11-8](#)
  - Control option for the WAE [11-4](#)
  - logging out [11-3](#)
  - Notifier tab [11-9](#)
  - quick tour [11-2](#)
  - Utilities option [11-11](#)
  - workflow [11-3](#)
- WAE devices
  - backing up [16-12](#)
  - controlled shutdown [16-36](#)
  - modifying configuration properties [10-1](#)
  - restoring [16-12](#)
  - supported [2-10](#)
- WAE packet return [5-15](#)
- WAFS Cache Cleanup utility [11-12](#)
- WAVE devices supported [2-10](#)
- WCCP
  - about [1-22, 5-3, 5-11](#)
  - Cisco Express Forwarding (CEF) [5-15](#)
  - configuring interception on SCs [5-22](#)
  - configuring interception on WAEs [5-17](#)
  - flow redirection, enabling and disabling [5-17](#)
  - GRE packet return [5-30](#)
  - ports used [2-6](#)
  - shutting down [5-27](#)
- WCCP-based routing
  - advanced configuration for a router [5-6](#)
  - advantages and disadvantages [2-20](#)
  - configuration guidelines [5-4](#)
- web application filter
  - configuring [10-20](#)
- web browser support [2-10](#)
- Windows Authentication
  - configuring in the Central Manager [7-16](#)
- Windows domain server settings [7-17](#)
- Windows name services [6-28](#)
- Windows print accelerator, about [1-9](#)
- Windows scaling, about [1-5](#)

