

Cisco Spark Board 55

Installation Guide: Floor Stand

- FR Guide d'installation : fixation au sol
- ES Guía de instalación: soporte para suelo
- PT Manual de Instalação: suporte de Chão
- IT Guida per l'installazione: cavalletto
- DE Installationshandbuch: Bodenständer

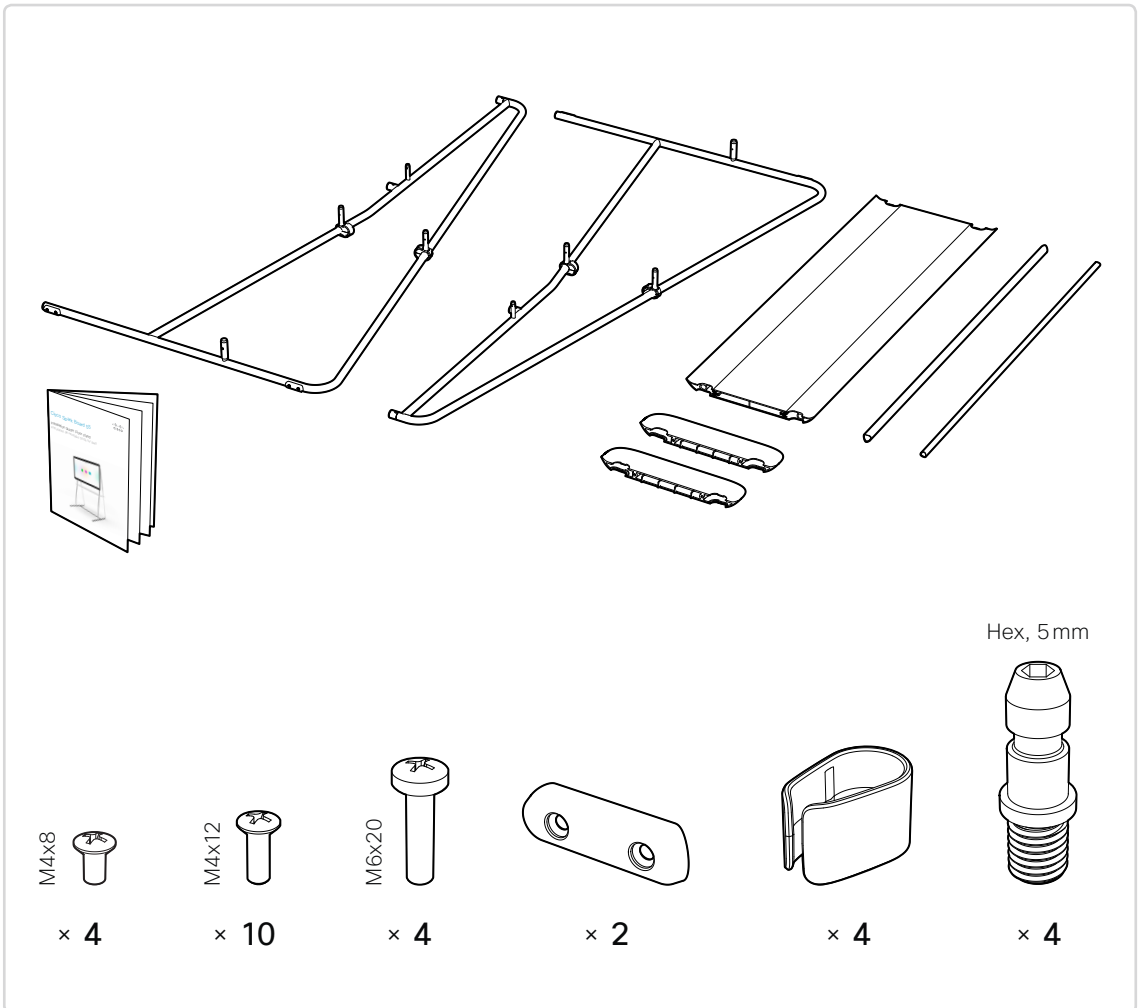

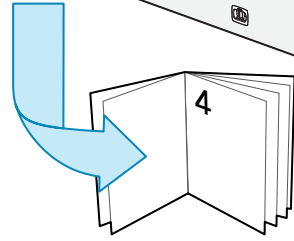
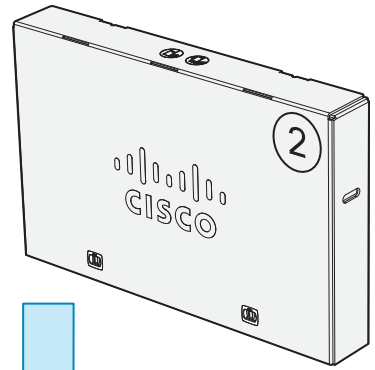
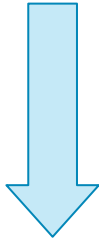
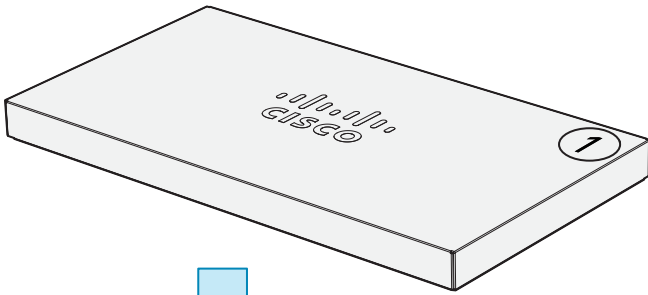



We recommend two people working together to mount this system.
Follow local regulations.

- FR Nous recommandons que deux personnes travaillent ensemble pour installer ce système. Respectez les réglementations locales en vigueur.
- ES Recomendamos montar el sistema entre dos personas. Siga las normativas locales.
- PT Recomendamos que a montagem deste sistema seja realizada por duas pessoas em conjunto. Siga as regulamentações locais.
- IT È consigliabile che il sistema venga installato da due persone. Attenersi alle norme locali.
- DE Für die Montage dieses Systems empfehlen wir die Zusammenarbeit von zwei Personen. Befolgen Sie die geltenden Bestimmungen.

Tools

Outils / Herramientas / Ferramentas / Utensili / Werkzeuge

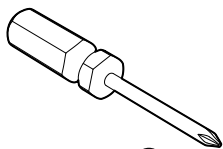

PH2 

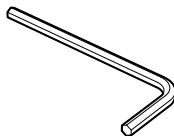

 Hex, 5 mm

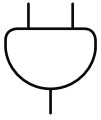

Power (100-240VAC, 3.5 A max, 50/60Hz)

Always use the provided power cable.

Keep the power plug and outlet easily accessible in case you need to disconnect the device from power.



FR Alimentation (100-240 V CA, 3,5 A max., 50/60 Hz)

Utilisez toujours le câble d'alimentation fourni.

Assurez-vous de pouvoir accéder facilement à la prise électrique au cas où vous auriez besoin de débrancher l'appareil.

ES Alimentación (100-240 VCA, 3,5 A máx., 50/60 Hz)

Utilice siempre el cable de alimentación proporcionado.

Mantenga el enchufe y la toma de corriente fácilmente accesibles por si tiene que desconectar el dispositivo de la fuente de alimentación.

PT Alimentação (100-240 V CA, 3,5 A máx, 50/60 Hz)

Utilize sempre o cabo de alimentação fornecido.

Mantenha a ficha e a tomada facilmente acessíveis no caso de precisar de desligar o dispositivo da alimentação.

IT Alimentazione (100-240 VAC, 3,5 A max, 50/60Hz)

Utilizzare sempre il cavo di alimentazione fornito.

Mantenere la spina e la presa di alimentazione facilmente accessibili nel caso occorra scollegare il dispositivo dall'alimentazione.

DE Stromaufnahme (100 bis 240 VAC, 3,5 A max., 50/60Hz)

Verwenden Sie immer das mitgelieferte Netzkabel.

Netzstecker und Steckdose sollten leicht zugänglich sein, falls Sie das Gerät von der Stromversorgung trennen müssen.

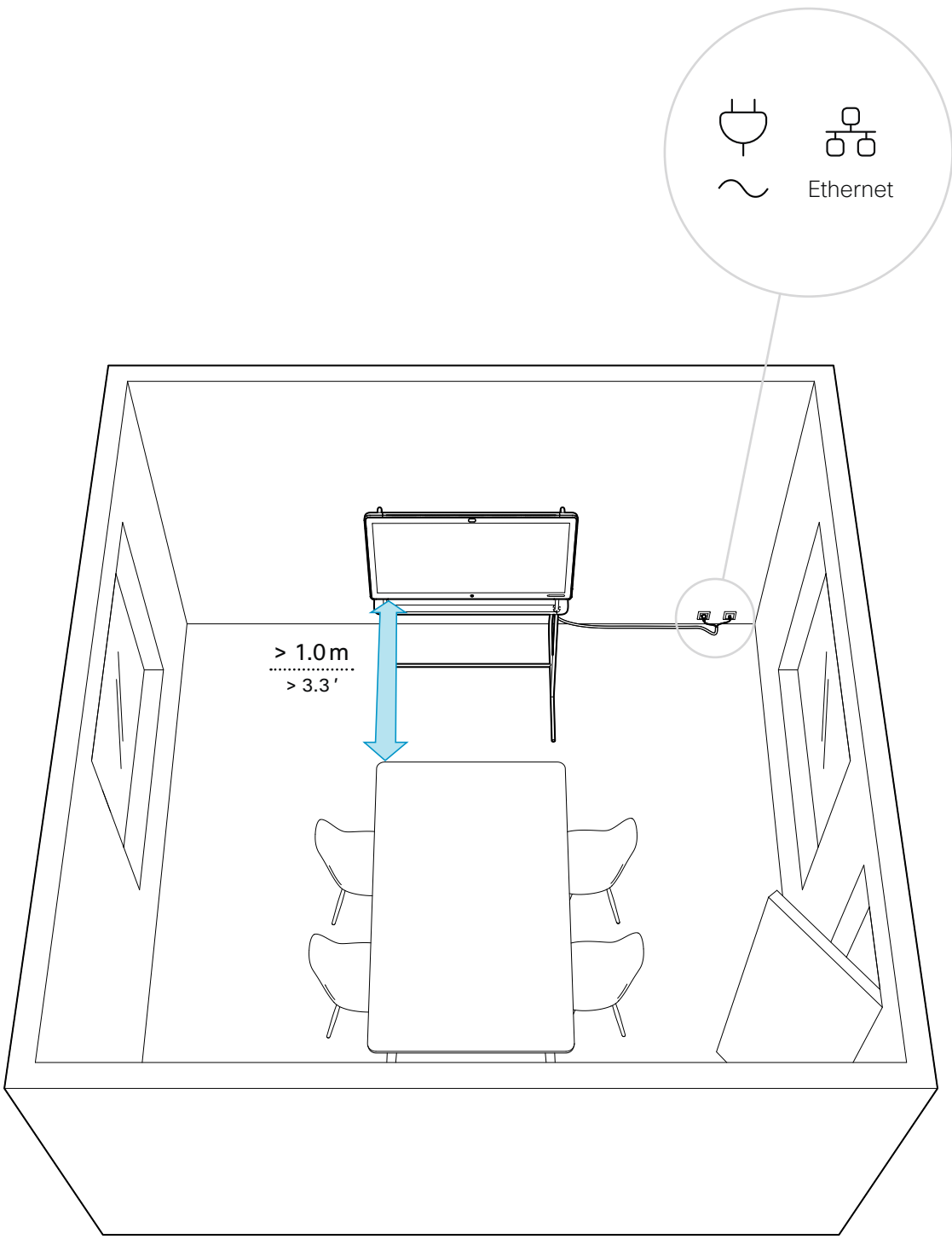

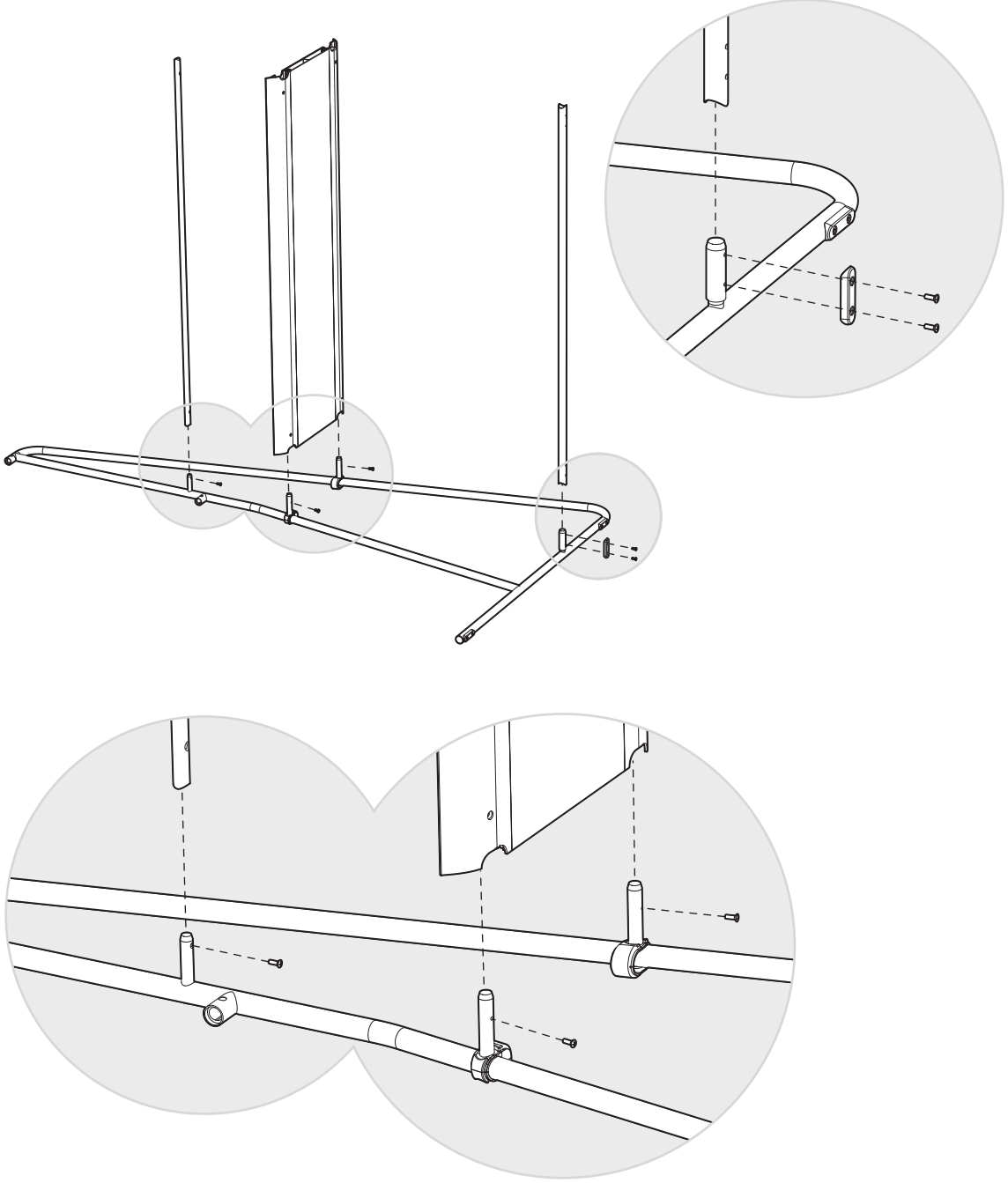

1

M4x12 × 5
PH2 ⊕
× 1

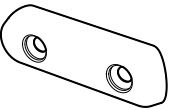

2

- M4x12  × 5
- PH2   × 1

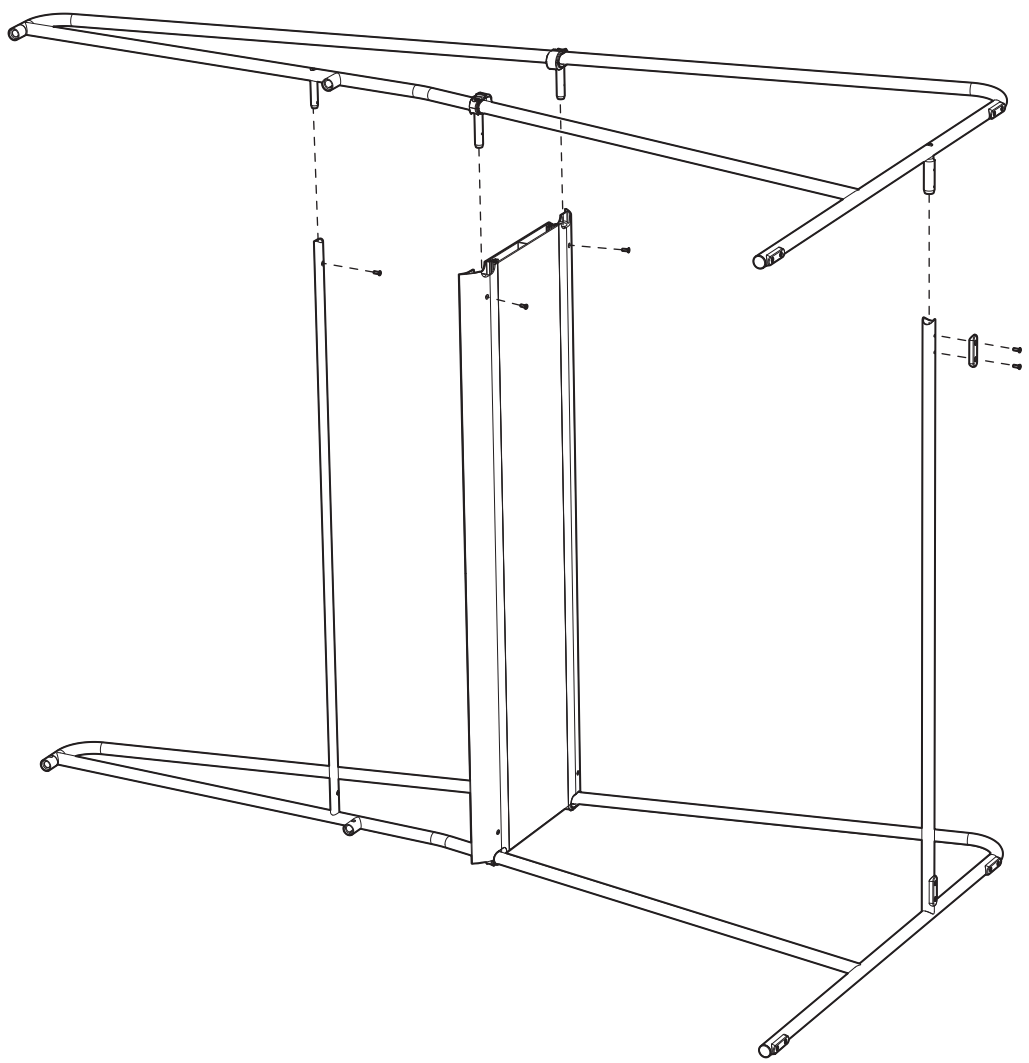

3

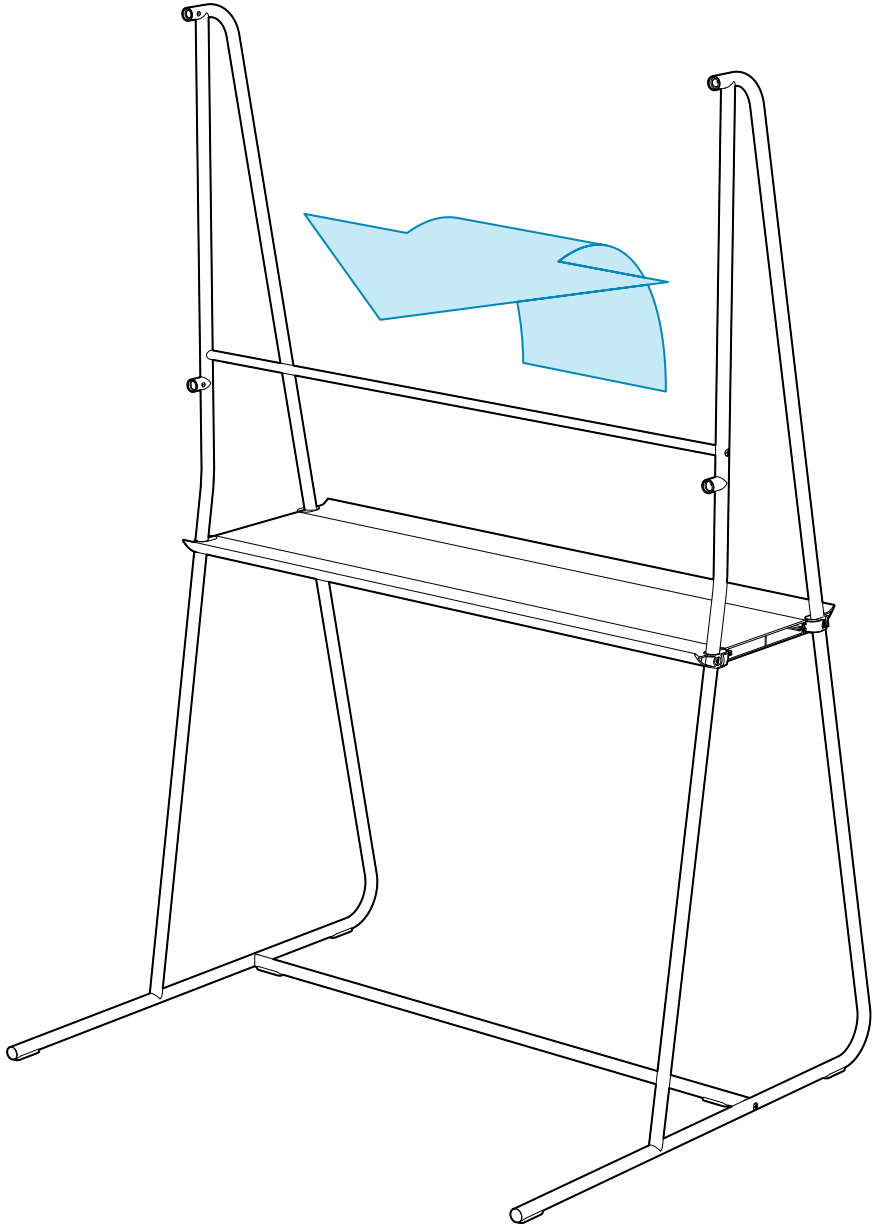

4

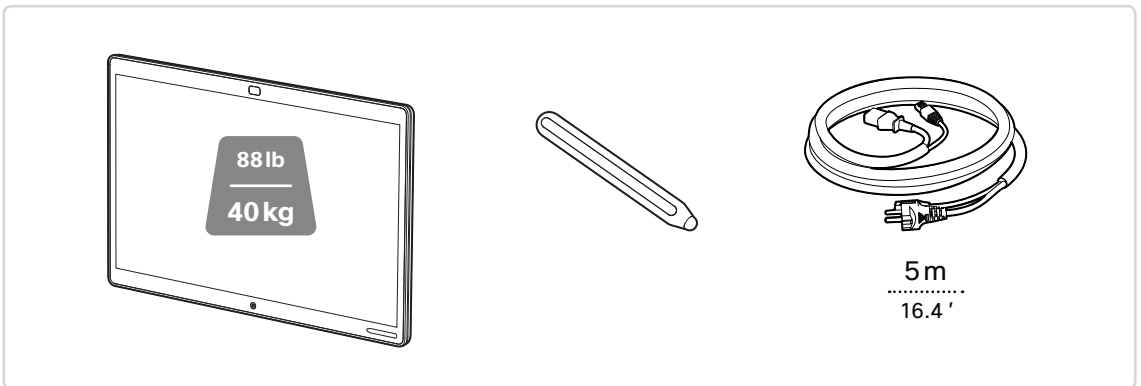
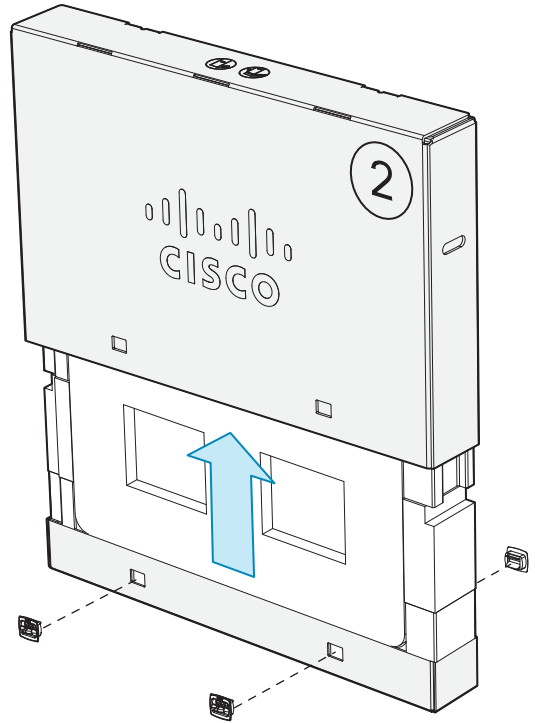
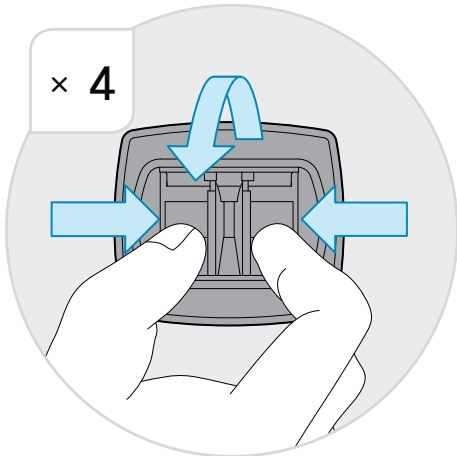

5



88lb
40kg

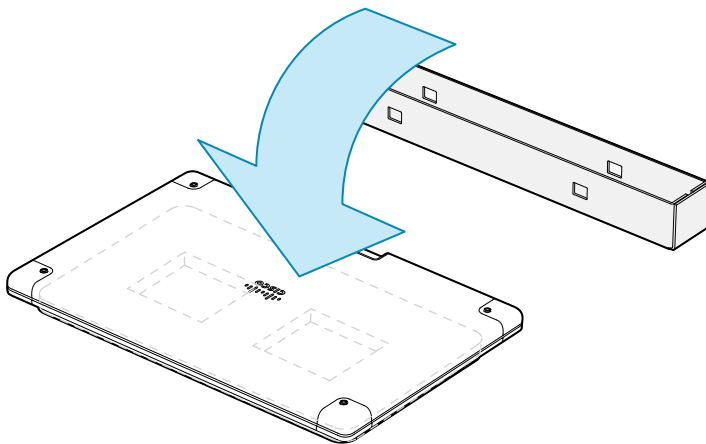
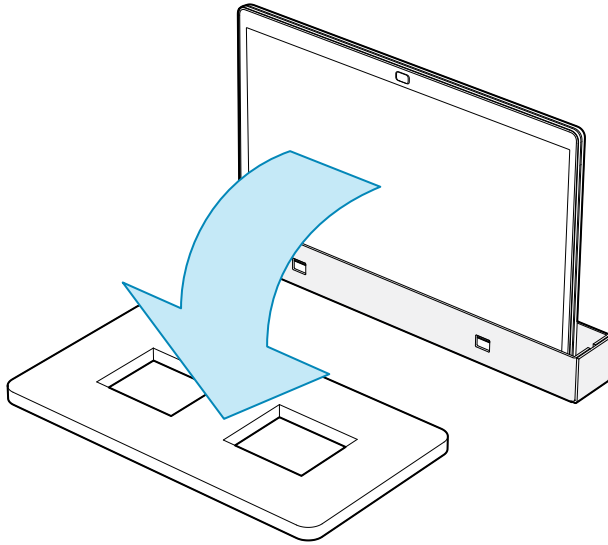

6

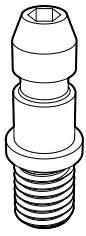

× 4

Hex, 5 mm

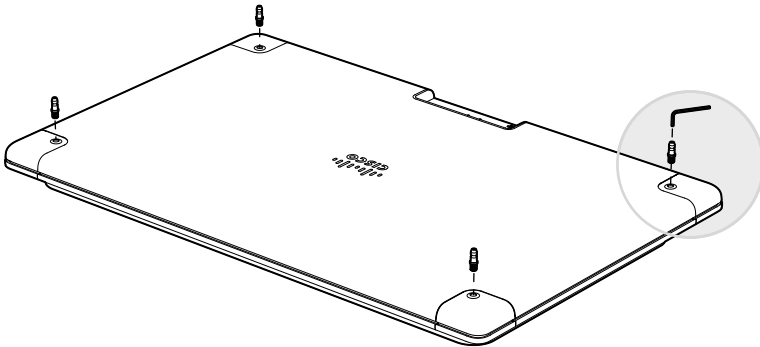
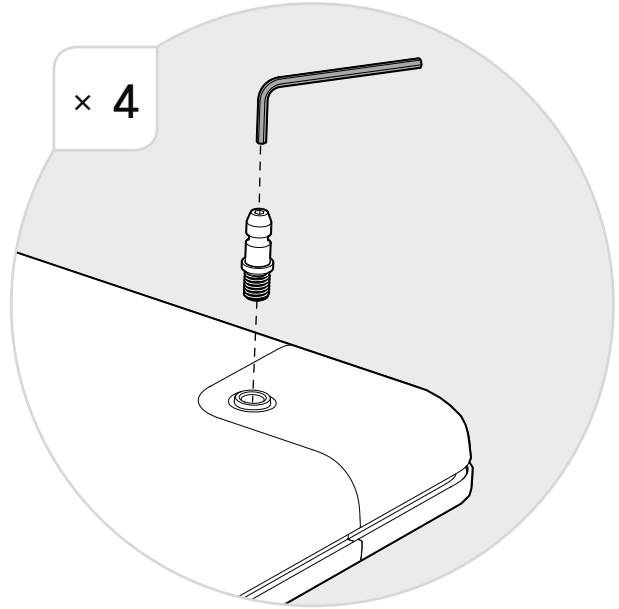

7



88lb
40 kg

M4x8
PH2



× 4

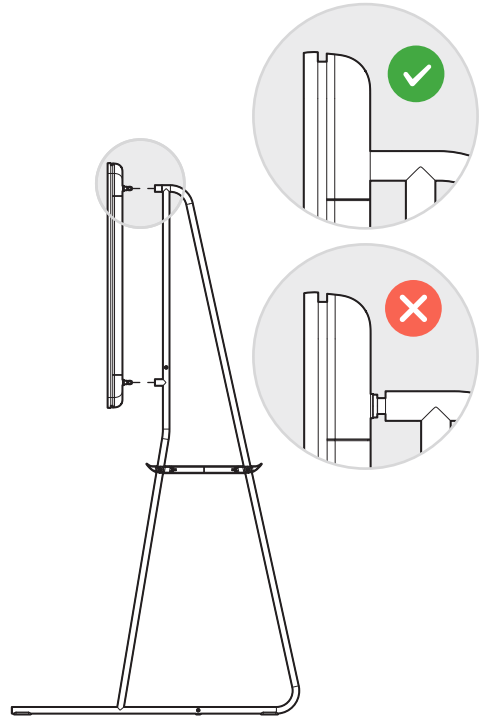
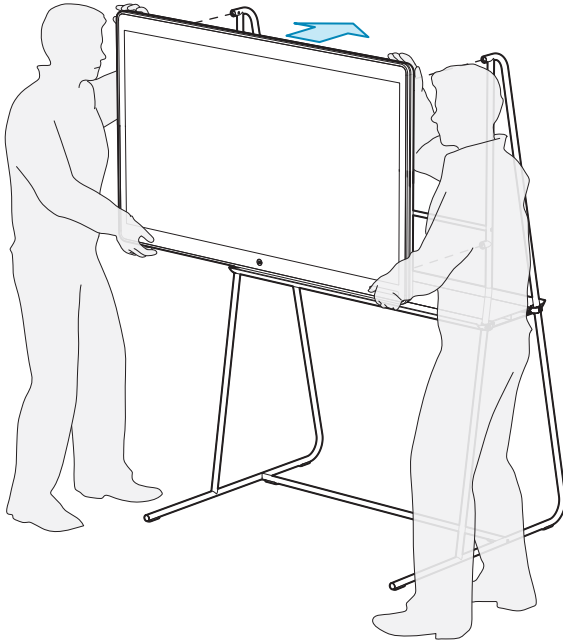

Hold the screen firmly in place until it is secured with four screws.

FR Maintenez l'écran fermement en place jusqu'à ce qu'il soit fixé avec quatre vis.

ES Sostenga la pantalla firmemente en su sitio hasta sujetarla con cuatro tornillos.

PT Mantenha firmemente o ecrã na devida posição até ficar preso com os quatro parafusos.

IT Mantenere lo schermo saldamente in posizione fino a quando sarà stato fissato con quattro viti.

DE Halten Sie den Bildschirm solange fest, bis er durch vier Schrauben gesichert ist.

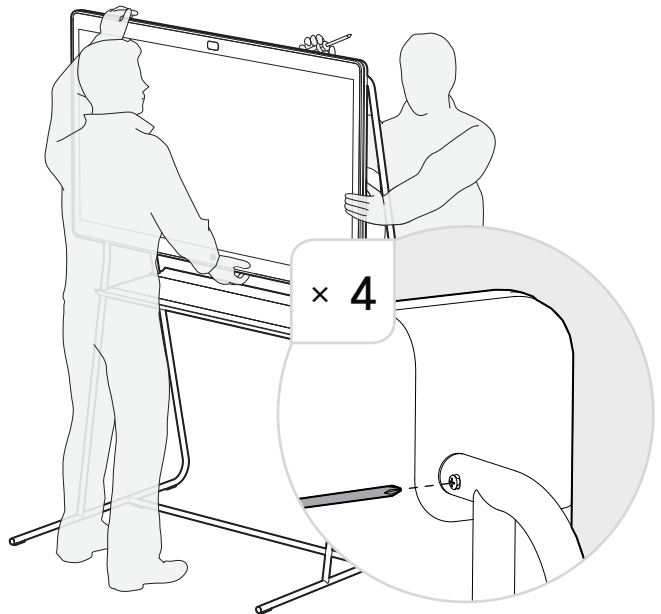

8

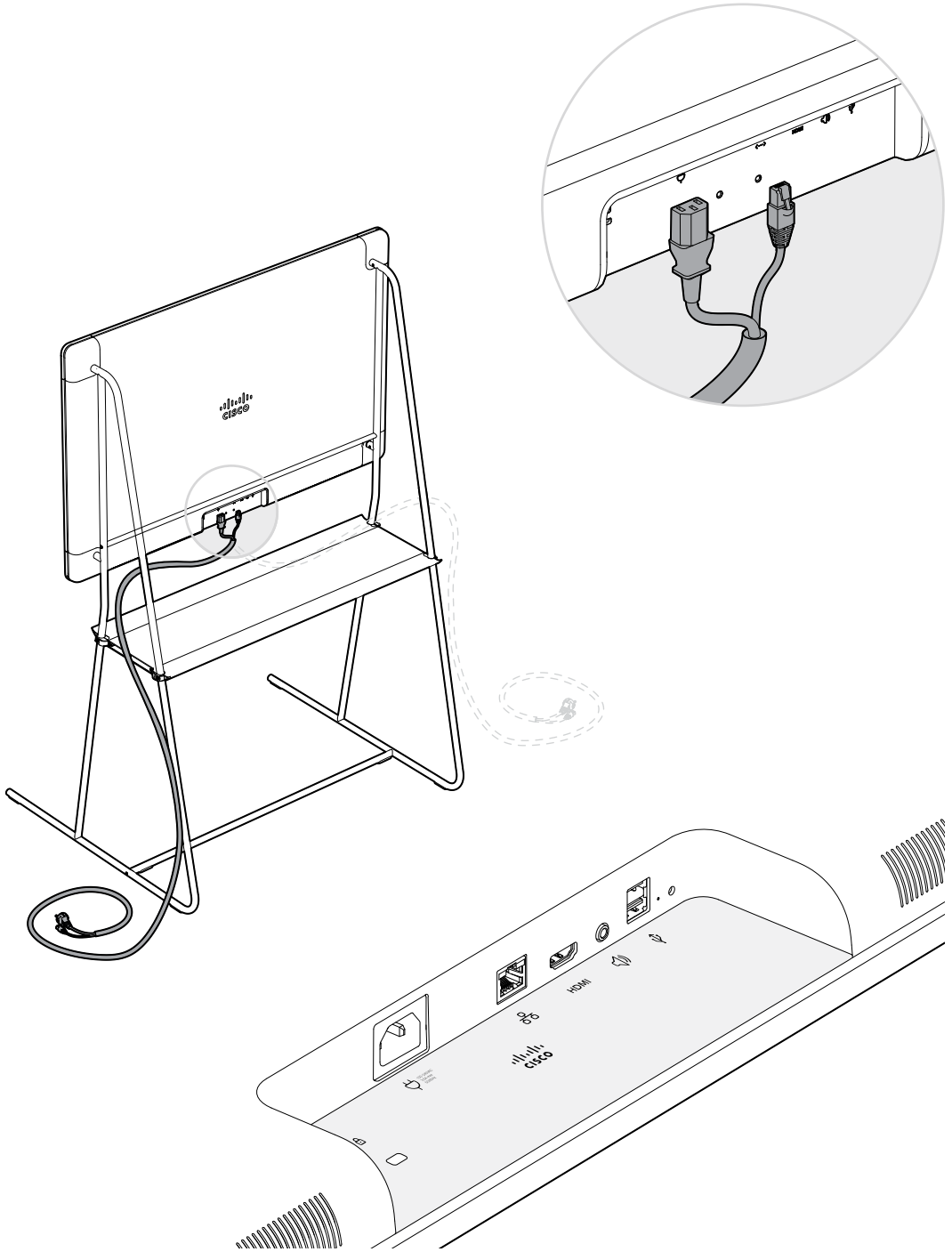
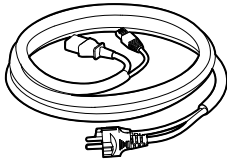

9

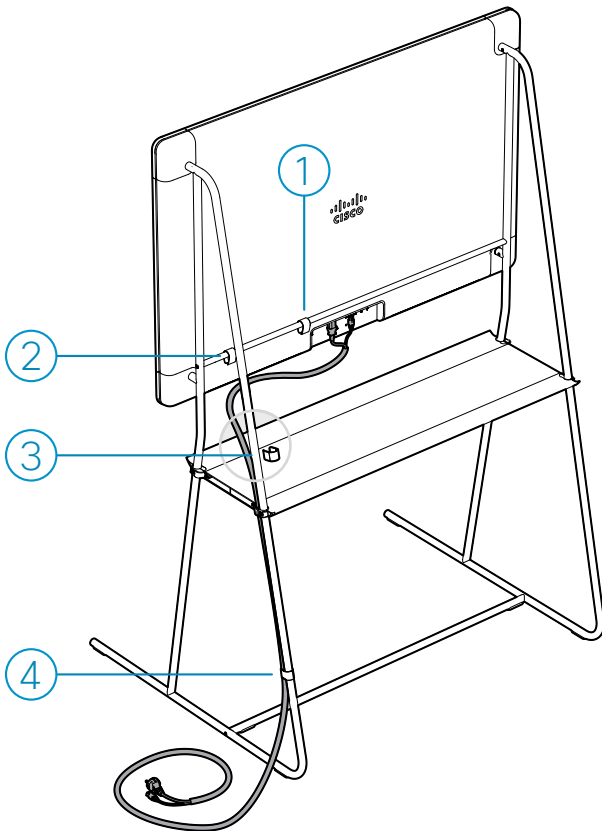
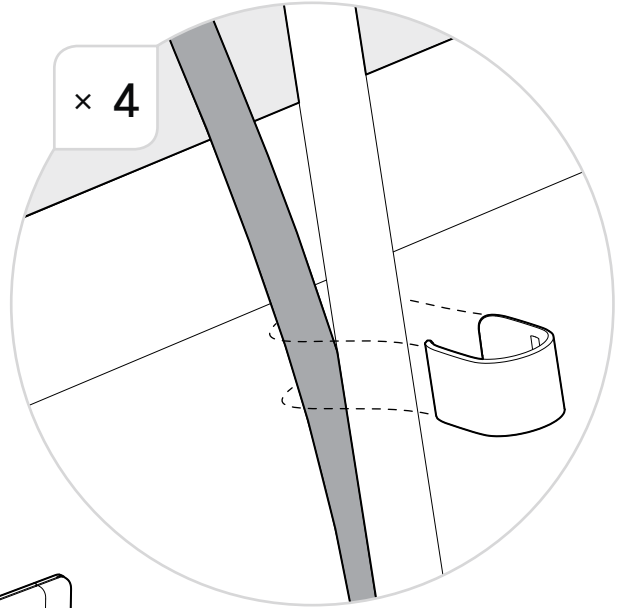
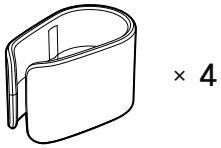

10

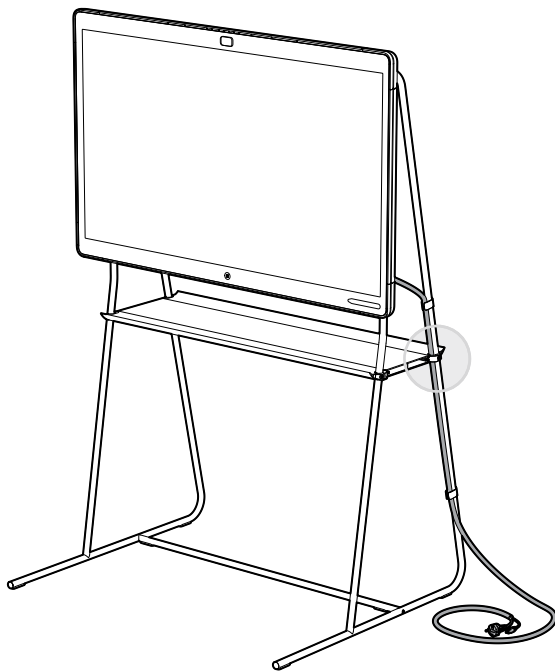
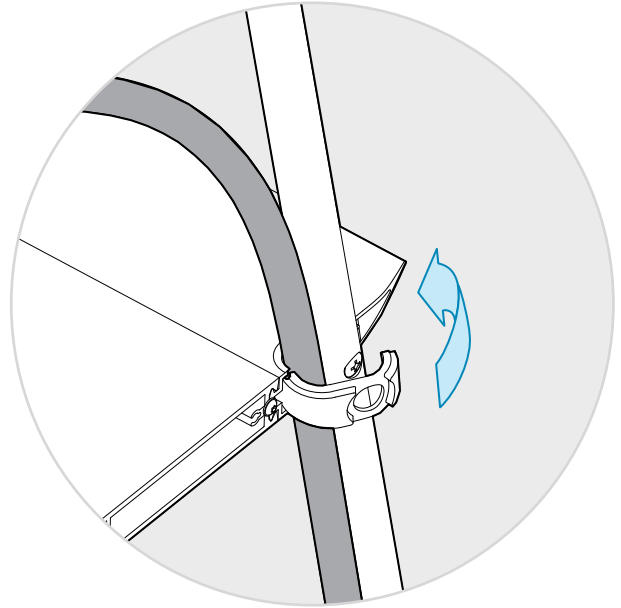

11

M6x20
PH2  × 4

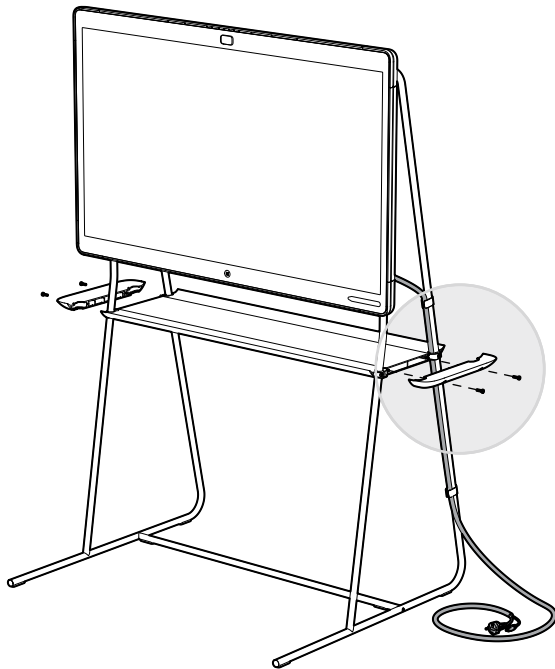
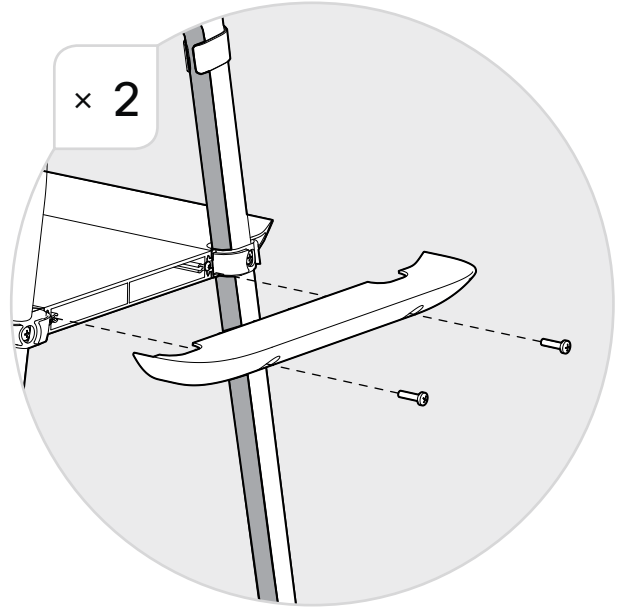

12

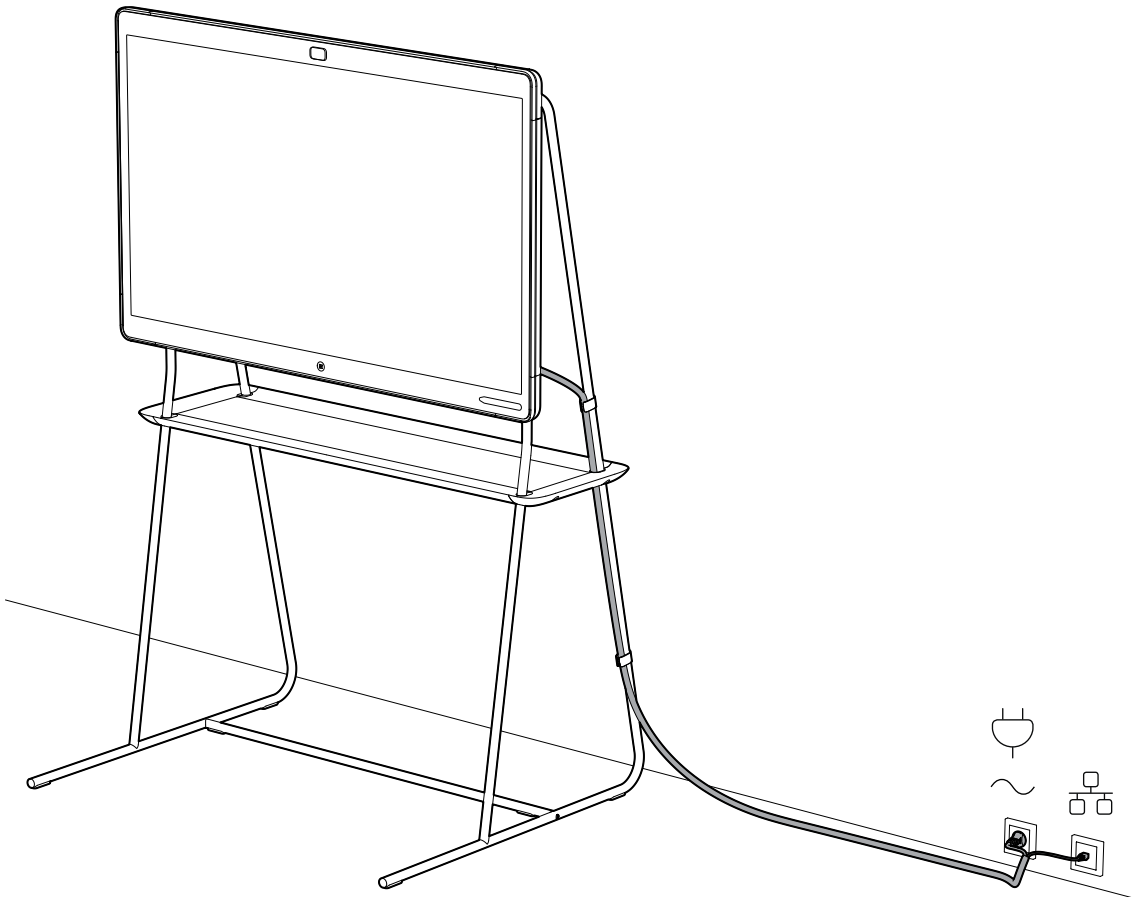

<http://help.ciscopark.com>

Look for Getting Started articles for the product.

- FR Consultez les guides d'utilisation du produit.
- ES Busque artículos en los que se explique cómo usar por primera vez el producto.
- PT Procure os artigos de Introdução relativos ao produto.
- IT Cercare la Guida introduttiva per il prodotto.
- DE Schauen Sie nach Onlinedokumentation zu den ersten Schritten mit dem Produkt.

Cisco Spark Board 55

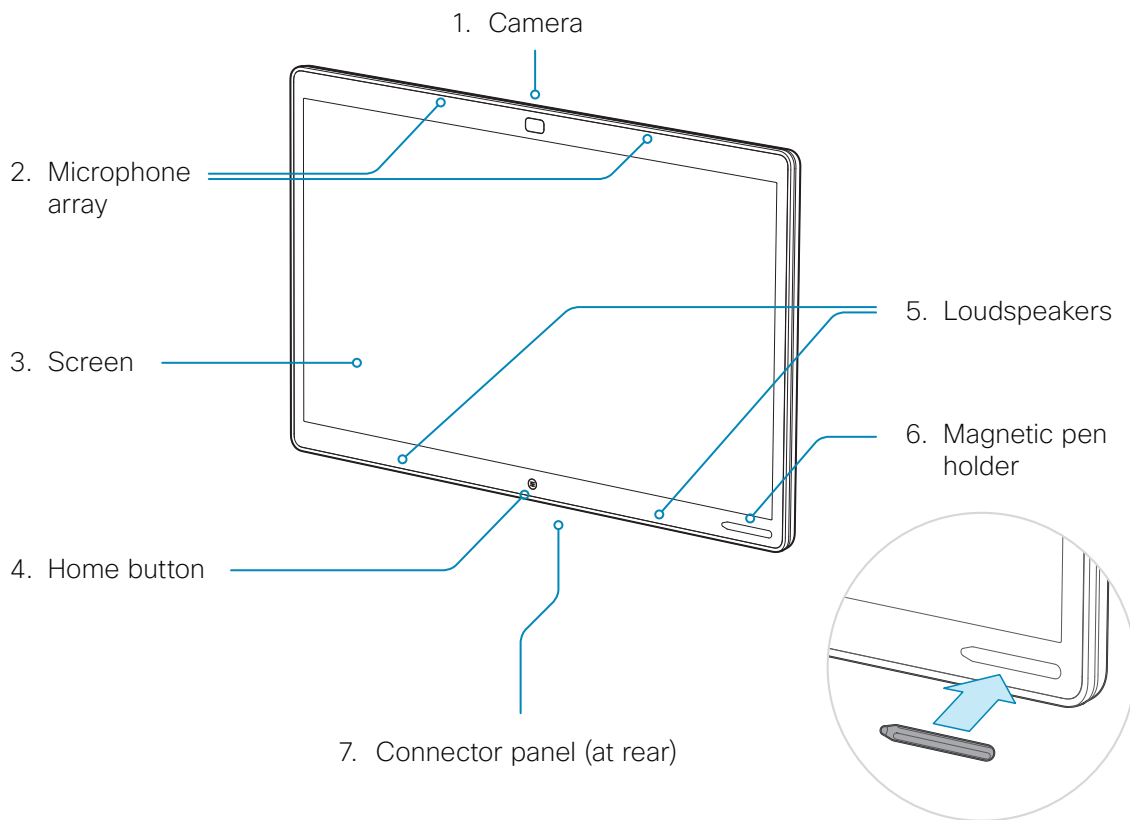

1. Camera

Caméra / Cámara / Câmara / Videocamera / Kamera

2. Microphone array

Matrice de microphones / Haz de micrófonos / Conjunto de microfones / Serie di microfoni / Mikrofon-Array

3. Screen

Écran / Pantalla / Ecrã / Display / Bildschirm

4. Home button

Bouton de menu / Botón de inicio / Botão de menu inicial / Pulsante Home / Home-Taste

5. Loudspeakers

Haut-parleurs / Altavoces / Altifalantes / Altoparlanti / Lautsprecher

6. Magnetic pen holder

Support magnétique pour stylet / Soporte magnético para rotulador / Suporte magnética para caneta / Supporto magnetico per lo stilo / Magnetischer Stifthalter

7. Connector panel (at rear)

Panneau de connexions (à l'arrière) / Panel de conexiones (en la parte posterior) / Painel de conectores (parte posterior) / Pannelo dei connettori (nella parte posteriore) / Anschlussfeld (auf der Rückseite)

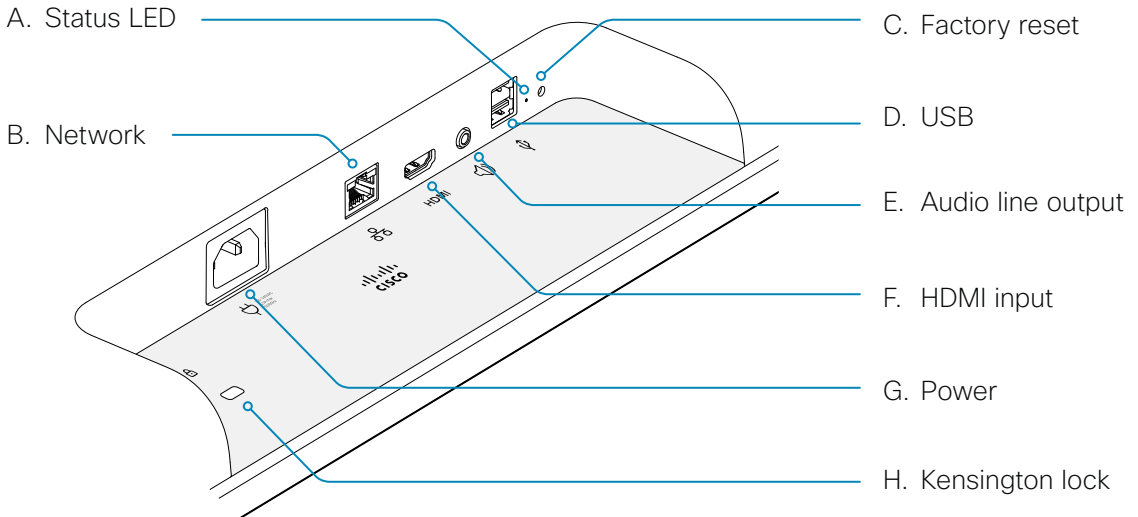

A. Status LED

Diode de statut / Estado LED / LED de estado / LED di stato / Status-LED

B. Network (Ethernet)

Réseau (Ethernet) / Red (Ethernet) / Rede (Ethernet) / Rete (Ethernet) / Netzwerk (Ethernet)

C. Factory reset

Rétablissement des paramètres d'usine / Restablecimiento de los parámetros de fábrica / Reposição de predefinições de fábrica / Ripristino dei valori predefiniti / Zurücksetzen auf Werkseinstellungen

D. 2 × USB 3.0

2 ports USB 3.0 / 2 × USB 3.0 / 2 × USB 3.0 / 2 × USB 3.0 / 2 × USB 3.0

E. Audio line output

Sortie de ligne audio / Salida de audio / Saída de áudio / Uscita di linea audio / Audioausgang

F. HDMI input

Entrée HDMI / Entrada de HDMI / Entrada HDMI / Ingresso HDMI / HDMI-Eingang

G. Power (100-240 VAC, 3.5A max, 50/60Hz)

Alimentation (100-240 V CA, 3,5 A max., 50/60 Hz) / Alimentación (100-240 VCA, 3,5 A máx., 50/60 Hz) / Alimentação (100-240V CA, 3,5A máx, 50/60Hz) / Alimentazione (100-240 VAC, 3,5 A max, 50/60Hz) / Eingangsleistung (100 bis 240 VAC, 3,5 A max., 50/60Hz)

H. Kensington lock

Verrou Kensington / Bloqueo Kensington / Cadeado Kensington / Blocco Kensington / Kensington-Lock

<http://help.ciscopark.com>

Additional support can be found in our on-line documentation. This includes regulatory compliance and safety information.

- FR Documents complémentaires d'aide en ligne. Informations relatives à la conformité et à la sécurité.
- ES Puede encontrar soporte adicional en nuestra documentación en línea. Se incluye la información de seguridad y de cumplimiento de las normas.
- PT Poderá encontrar suporte adicional na documentação online. Inclui regulamentação de conformidade e informações de segurança.
- IT Ulteriori informazioni sul prodotto sono disponibili nella documentazione online. Tale documentazione include la conformità alle normative e informazioni sulla sicurezza.
- DE Zusätzlichen Support finden Sie in unserer Onlinedokumentation, die u.a. Informationen zur Erfüllung gesetzlicher Auflagen sowie zur Sicherheit enthält.

<http://www.cisco.com/go/projectworkplace>

Explore the Cisco Project Workplace to find inspiration and guidelines when preparing your office or meeting room for video conferencing.

- FR Consultez le portail Cisco Project Workplace pour trouver l'inspiration et des guides lorsque vous préparez votre bureau ou votre salle pour une vidéoconférence.
- ES Explore Cisco Project Workplace para encontrar la inspiración y las directrices necesarias para preparar su oficina o sala de reuniones para videoconferencias.
- PT Explore o Cisco Project Workplace para encontrar inspiração e diretrizes ao preparar o seu escritório ou a sua sala de conferências para a realização de videoconferências.
- IT Consultate il Cisco Project Workplace per trovare spunti e linee guida per la predisposizione di uffici e sale riunioni per videoconferenze.
- DE Erkunden Sie Cisco Project Workplace, um Inspiration und Richtlinien für die Vorbereitung Ihres Büros oder Ihres Konferenzraums für Videokonferenzen zu finden.



Cisco Systems Inc.
Corporate Headquarters
170 West Tasman Dr.
San Jose, CA 95134
USA

<http://www.cisco.com/go/offices>

Cisco and the Cisco logo are trademarks or registered trademarks of Cisco and/or its affiliates in the U.S. and other countries. To view a list of Cisco trademarks, go to this URL: www.cisco.com/go/trademarks. Third-party trademarks mentioned are the property of their respective owners. The use of the word partner does not imply a partnership relationship between Cisco and any other company. (1110R)

FR Cisco et le logo Cisco sont des marques commerciales ou déposées de Cisco et/ou de ses filiales aux États-Unis et dans d'autres pays. Pour consulter la liste des marques commerciales de Cisco, visitez la page : www.cisco.com/go/trademarks. Les autres marques commerciales mentionnées dans le présent document sont la propriété de leurs détenteurs respectifs. L'utilisation du terme « partenaire » n'implique pas de relation de partenariat entre Cisco et toute autre entreprise. (1110R)

ES Cisco y el logotipo de Cisco son marcas comerciales o registradas de Cisco y/o sus filiales en Estados Unidos y otros países. Si desea consultar una lista de las marcas comerciales de Cisco, visite: www.cisco.com/go/trademarks. Las marcas comerciales de terceros que aquí se mencionan pertenecen a sus respectivos propietarios. El uso de la palabra "partner" no implica la existencia de una asociación entre Cisco y cualquier otra empresa. (1110R)

PT Cisco e o logótipo da Cisco são marcas comerciais ou marcas comerciais registadas da Cisco e/ou das respectivas empresas afiliadas nos EUA e noutros países. Para ver uma lista de marcas comerciais da Cisco, aceda a este URL: www.cisco.com/go/trademarks. As marcas comerciais de terceiros mencionadas são propriedade dos respectivos proprietários. A utilização da palavra parceiro não implica uma relação de parceria entre a Cisco e qualquer outra empresa. (1110R)

IT Cisco e il logo Cisco sono marchi o marchi registrati di Cisco e/o dei relativi affiliati negli Stati Uniti e in altri paesi. Per visualizzare l'elenco di marchi Cisco, visitare il sito Web all'indirizzo: www.cisco.com/go/trademarks. I marchi commerciali di terze parti citati sono proprietà dei rispettivi titolari. L'utilizzo del termine partner non implica una relazione di partnership tra Cisco e altre aziende. (1110R)

DE Cisco und das Cisco Logo sind Marken oder eingetragene Marken von Cisco und/oder Partnerunternehmen in den Vereinigten Staaten und anderen Ländern. Eine Liste der Cisco Marken finden Sie unter www.cisco.com/go/trademarks. Die genannten Marken anderer Anbieter sind Eigentum der jeweiligen Inhaber. Die Verwendung des Begriffs „Partner“ impliziert keine gesellschaftsrechtliche Beziehung zwischen Cisco und anderen Unternehmen. (1110R)