

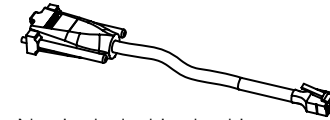

- 1** The kit consists of:
- Three cables of 6.5m length with repeaters
  - One ferrite to be clamped around the cable
  - Power supply to be connected to the camera
  - Mains cables fitting your region.

In addition you will need the cable that came with the Cisco TelePresence Codec.

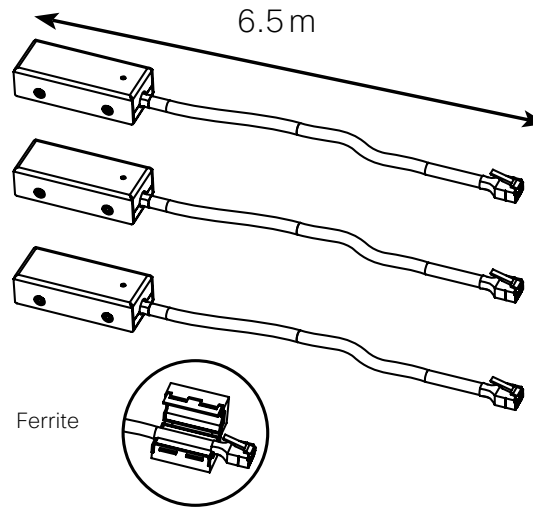

Not included in the kit  
(comes with your codec).

Power supply (not shown) & mains cables (not shown) as well as three cables and a ferrite are included in the kit.

- 2** Connect as shown. Maximum number of repeaters is 3. The cable from the last repeater to the codec must be maximum 5\* metres. This gives a maximum total length of 24.5\* metres.

The codec

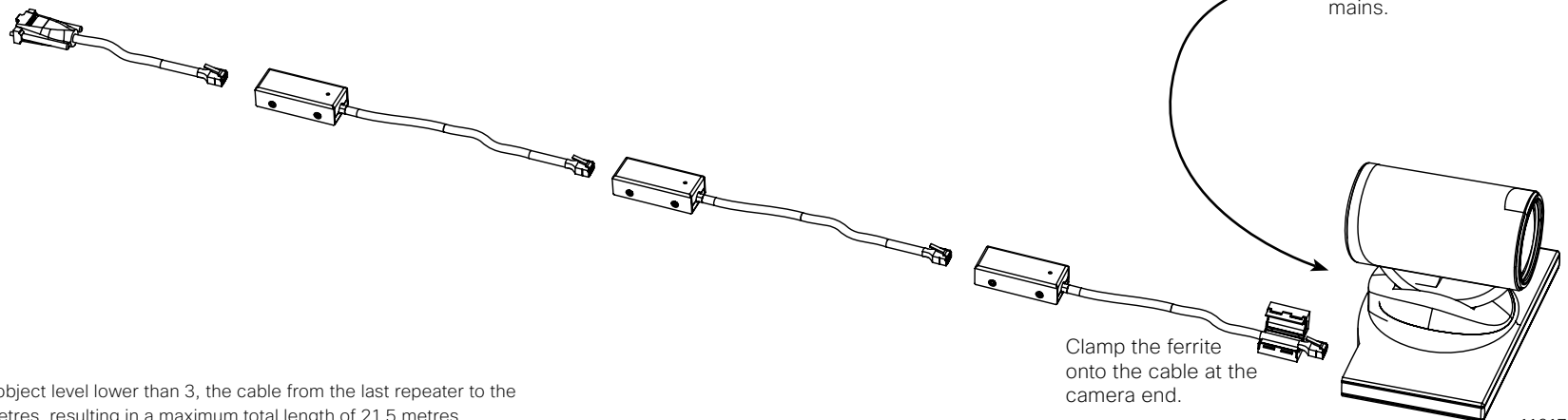

\* For Codec 6000 MXP with object level lower than 3, the cable from the last repeater to the codec must be maximum 2 metres, resulting in a maximum total length of 21.5 metres.