

# Cisco Compute Hyperconverged with Nutanix

## HCIAF240C M6 All-Flash Server

A printed version of this document is only a copy and not necessarily the latest version. Refer to the following link for the latest released version:

<https://www.cisco.com/c/en/us/products/hyperconverged-infrastructure/compute-hyperconverged/datasheet-listing.html>



# CONTENTS

<b>OVERVIEW</b>	<b>3</b>
<b>DETAILED VIEWS</b>	<b>5</b>
Chassis Front View - HClAF240C-M6SX (All-Flash)	5
Chassis Rear View - HClAF240C-M6SX (All-Flash)	6
<b>BASE SERVER STANDARD CAPABILITIES and FEATURES</b>	<b>8</b>
<b>CONFIGURING the SERVER</b>	<b>10</b>
STEP 1 VERIFY SERVER SKU	11
STEP 2 SELECT MANAGMENT MODE (REQUIRED)	12
STEP 3 SELECT RISER CARDS (REQUIRED)	13
STEP 4 SELECT CPU(s)	14
STEP 5 SELECT MEMORY	18
Memory Configurations, Features, and Modes	19
STEP 6 SELECT DRIVE CONTROLLERS	23
Cisco 12G SAS HBA	23
STEP 7 SELECT DRIVES	24
STEP 8 SELECT CISCO COMPUTE HYPERCONVERGED CONNECTIVITY (REQUIRED)	26
A. FI Managed Mode - HCI connectivity:	26
B. Intersight Standalone Mode (IS Managed) - HCI connectivity:	27
STEP 9 SELECT PCIe CARD(s) (OPTIONAL FOR FI MANAGED MODE)	28
ORDER OPTIONAL PCIe OPTION CARD ACCESSORIES	30
STEP 10 ORDER GPU CARDS (OPTIONAL)	31
STEP 11 ORDER POWER SUPPLY	32
STEP 12 SELECT INPUT POWER CORD(s)	33
STEP 13 ORDER TOOL-LESS RAIL KIT AND OPTIONAL REVERSIBLE CABLE MANAGEMENT ARM	37
STEP 14 ORDER SECURITY DEVICES (OPTIONAL)	38
STEP 15 SELECT HYPERVISOR	39
STEP 16 SELECT NUTANIX SOFTWARE AND NUTANIX PROFESSIONAL SERVICES	40
Top Level Nutanix Software And Professional Services PIDs	41
Nutanix Software And Professional Services PID Decoder	43
Nutanix Software PIDs and Description	44
Professional Services PIDs and Description	65
Nutanix Support:	76
Software With Professional Services PID Mapping	77
STEP 17 CISCO INTERSIGHT (REQUIRED)	86
<b>SUPPLEMENTAL MATERIAL</b>	<b>88</b>
Block Diagram	88
Hyperconverged Systems	89
Retrofit of Existing UCS Servers	90
Serial Port Details	93
KVM Cable	93
Chassis	94
Risers	96
Riser Card Configuration and Options	98
Riser 1A	98
Riser 2A	99
Riser 3A	100
Riser 3C	101
<b>UPGRADING or REPLACING CPUs</b>	<b>102</b>
<b>UPGRADING or REPLACING MEMORY</b>	<b>103</b>

---

# CONTENTS

**TECHNICAL SPECIFICATIONS . . . . . 104**  
    Dimensions and Weight . . . . . 104  
    Power Specifications . . . . . 105  
    Environmental Specifications . . . . . 109  
    Extended Operating Temperature Hardware Configuration Limits . . . . . 110  
    Compliance Requirements . . . . . 111

## OVERVIEW

Cisco Compute Hyperconverged with Nutanix is a hyperconverged infrastructure solution integrating Cisco's best-in-class compute (Cisco Unified Computing System), datacenter networking, and SaaS infrastructure management platform (Cisco Intersight) with Nutanix's market-leading hyperconverged storage software, Nutanix Cloud Platform

The Cisco Compute Hyperconverged with Nutanix family of appliances delivers pre-configured UCS servers that are ready to be deployed as nodes to form Nutanix clusters in a variety of configurations. Each server appliance contains three software layers: UCS server firmware, hypervisor (Nutanix AHV), and hyperconverged storage software (Nutanix AOS)

Physically, nodes are deployed into clusters, with a cluster consisting of Cisco Compute Hyperconverged All-Flash Servers. Clusters support a variety of workloads like virtual desktops, general-purpose server virtual machines in edge, data center and mission-critical high-performance environments.

The HCIAF240C M6 All-Flash Server extends the capabilities of Cisco's Compute Hyperconverged portfolio in a 2U form factor with the addition of the 3rd Gen Intel® Xeon® Scalable Processors (Ice Lake), 16 DIMM slots per CPU for 3200-MHz DDR4 DIMMs with DIMM capacity points up to 256GB.

### Cluster Scale:

Nutanix clusters can be scaled out to the max cluster server limit documented by Nutanix. The minimum depends on the management mode.

### Drives:

- HCIAF240C-M6SX (All-Flash) (see [1 on page 4](#)):
  - Up to 24 front SFF SAS/SATA SSDs.

### Drive Controllers:

The server provides two internal slots for the following:

- Two slots for Cisco 12G SAS pass-through HBAs. Each HBA controls up to 16 SAS/SATA drives

**These servers can be interconnected and managed in two different ways:**

**UCS Managed mode:** The nodes are connected to a pair of Cisco UCS® 6400 Series or a pair of Cisco UCS 6500 Series fabric interconnects and managed as a single system using UCS Manager. The minimum number of nodes in such a cluster is three. These clusters can support both general-purpose deployments and mission-critical high-performance environments.



**NOTE:** One-node and two-node clusters are not supported with this solution.

---

**Intersight Standalone mode:** The nodes are connected to a pair of Top-of-Rack (ToR) switches and servers are centrally managed using Cisco Intersight®. While a minimum of three nodes are required to deploy a standard Nutanix cluster, we also offer an option to deploy a single node cluster and a two-node cluster for Edge and branch locations and situations that already have a high-performance network fabric installed. Refer to Nutanix documentation on [single node](#).

See [Figure 1 on page 4](#) for front and rear views of all the configurations of the HClAF240C M6 All-Flash Server.

**Figure 1** Cisco HClAF240C M6 All-Flash Server

HClAF240C-M6SX (All-Flash)

24 Front drives are SAS/SATA

Front View (see [Figure 2 on page 5](#) for details)



Rear View (all slots shown unpopulated - see [Figure 3 on page 6](#) for details)



## DETAILED VIEWS

### Chassis Front View - HCIAF240C-M6SX (All-Flash)

Figure 2 shows the front View of the HCIAF240C-M6SX (All-Flash) Server configured with 24 front drives.

Figure 2 Chassis Front View: HCIAF240C-M6SX (All-Flash)

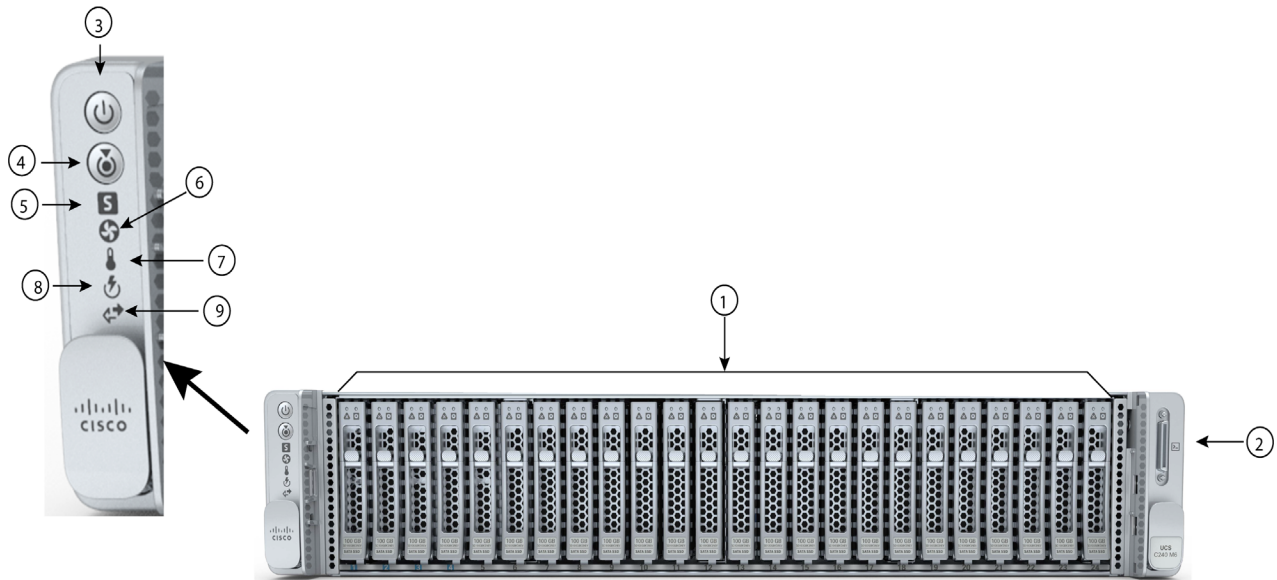

1	Drive bays 1- 24 support SAS/SATA solid state drives (SSDs) only	6	Fan status LED
2	KVM connector (used with KVM cable that provides two USB 2.0, one VGA, and one serial connector)	7	Temperature status LED
3	Power button/Power status LED	8	Power supply status LED
4	Unit Identification button/LED	9	Network link activity LED
5	System status LED	-	-

## Chassis Rear View - HCIAF240C-M6SX (All-Flash)

Figure 3 Chassis Rear View: HCIAF240C-M6SX (All-Flash)

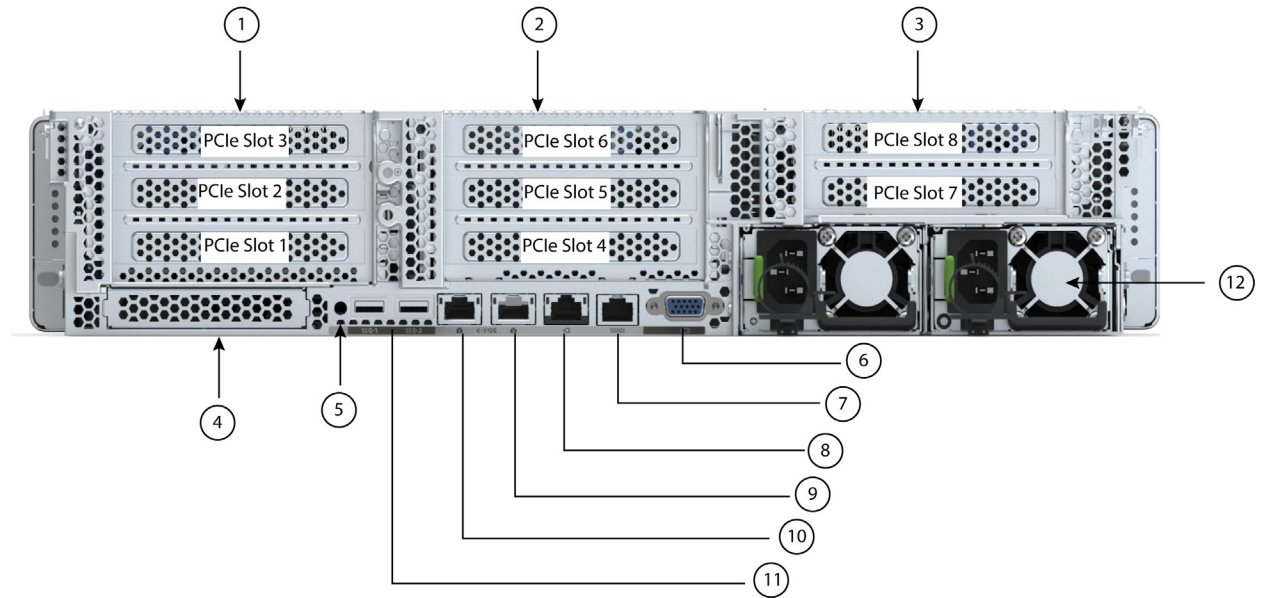

1	<p>There are two Riser 1 options:</p> <p>Riser 1A (CPU1 control)</p> <ul style="list-style-type: none"> <li>■ Supports three PCIe slots:                             <ul style="list-style-type: none"> <li>• Slot 1 is full-height, 3/4 length, x8, NCSI</li> <li>• Slot 2 is full-height, full-length, x16, NCSI</li> <li>• Slot 3 is full-height, full-length, x8, no NCSI</li> </ul> </li> </ul>	7	COM port (RJ45 connector)
2	<p>Riser 2A (CPU2 control)</p> <ul style="list-style-type: none"> <li>■ Supports three PCIe slots:                             <ul style="list-style-type: none"> <li>• Slot 4 is full-height, 3/4 length, x8</li> <li>• Slot 5 is full-height, full-length, x16</li> <li>• Slot 6 is full-height, full length, x8</li> </ul> </li> </ul>	8	1GBE dedicated Ethernet management port
3	<p>There are three Riser 3 options:</p> <p>Riser 3A (CPU2 control)</p> <ul style="list-style-type: none"> <li>■ Supports two PCIe slots:                             <ul style="list-style-type: none"> <li>• Slot 7 is full-height, full-length, x8, no NCSI</li> <li>• Slot 8 is full-height, full-length, x8, no NCSI</li> </ul> </li> </ul> <p>Riser 3C (for GPU, CPU2 control)</p> <ul style="list-style-type: none"> <li>■ Supports one full-height, full-length, double-wide GPU (PCIe slot 7 only), x16</li> <li>■ Slot 8 is blocked by double-wide GPU</li> </ul>	9 -10	<p>Dual 1/10GBE Ethernet ports (LAN1, LAN2)</p> <p>LAN1 is left connector,</p> <p>LAN2 is right connector</p>
4	Modular LAN-on-motherboard (mLOM) card slot (x16)	11	USB 3.0 ports (two)
5	System ID pushbutton/LED	12	Power supplies (two)
6	VGA display port (DB15 connector)	-	-

**NOTE:**

- For GPU support on a particular riser slot, see [Table 17 on page 31](#)
  - See [Riser Card Configuration and Options, page 98](#) for details.
-



## BASE SERVER STANDARD CAPABILITIES and FEATURES

*Table 1* lists the capabilities and features of the base server. Details about how to configure the server for a particular feature or capability (for example, number of processors, disk drives, or amount of memory) are provided in *CONFIGURING the SERVER, page 10*.

**Table 1 Capabilities and Features**

Capability/Feature	Description
Chassis	Two rack unit (2RU) chassis
CPU	One or two 3rd Gen Intel® Xeon® Scalable Processors (Ice Lake)
Chipset	Intel® C621A series chipset
Memory	32 slots for registered DIMMs (RDIMMs) or load-reduced DIMMs (LRDIMMs)
Multi-bit Error Protection	This server supports multi-bit error protection.
Video	<p>The Cisco Integrated Management Controller (CIMC) provides video using the Matrox G200e video/graphics controller:</p> <ul style="list-style-type: none"> <li>■ Integrated 2D graphics core with hardware acceleration</li> <li>■ Embedded DDR memory interface supports up to 512 MB of addressable memory (8 MB is allocated by default to video memory)</li> <li>■ Supports display resolutions up to 1920 x 1200 16bpp @ 60Hz</li> <li>■ High-speed integrated 24-bit RAMDAC</li> <li>■ Single lane PCI-Express host interface running at Gen 1 speed</li> </ul>
Power subsystem	<p>Up to two of the following hot-swappable power supplies:</p> <ul style="list-style-type: none"> <li>■ 1050 W (AC)</li> <li>■ 1050 W (DC)</li> <li>■ 1600 W (AC)</li> <li>■ 2300 W (AC)</li> </ul> <p>One power supply is mandatory; one more can be added for 1 + 1 redundancy.</p>
Front Panel	A front panel controller provides status indications and control buttons.
ACPI	This server supports the advanced configuration and power interface (ACPI) 6.2 standard.
Fans	Six hot-swappable fans for front-to-rear cooling
Expansion slots	<ul style="list-style-type: none"> <li>■ Riser 1A (3 PCIe slots)</li> <li>■ Riser 2A (3 PCIe slots)</li> <li>■ Riser 3A (2 PCIe slots)</li> <li>■ Riser 3C (1 full-length, double-wide GPU)</li> </ul> <p> <b>Note:</b> Not all risers are available in every server configuration option.</p> <p>For more details on the variations of riser 1, riser 2, and riser 3, see <a href="#">Riser Card Configuration and Options, page 98</a>.</p>

Capability/Feature	Description
Interfaces	<ul style="list-style-type: none"> <li>■ Rear panel                             <ul style="list-style-type: none"> <li>• One 1Gbase-T RJ-45 management port</li> <li>• Two 10Gbase-T LOM ports</li> <li>• One RS-232 serial port (RJ45 connector)</li> <li>• One DB15 VGA connector</li> <li>• Two USB 3.0 port connectors</li> <li>• One flexible modular LAN on motherboard (mLOM) slot that can accommodate various interface cards</li> </ul> </li> <li>■ Front panel                             <ul style="list-style-type: none"> <li>• One KVM console connector (supplies two USB 2.0 connectors, one VGA DB15 video connector, and one serial port (RS232) RJ45 connector)</li> </ul> </li> </ul>
Internal storage devices	<p><u>Drive storage:</u></p> <p><b>HCI AF240C-M6SX (All-Flash):</b></p> <ul style="list-style-type: none"> <li>■ Two to twenty-four SAS/SATA SSD or Two to twenty-four SED SAS/SATA SSD</li> </ul>
Integrated management processor	<p>Baseboard Management Controller (BMC) running Cisco Integrated Management Controller (CIMC) firmware.</p> <p>Depending on your CIMC settings, the CIMC can be accessed through the 1GE dedicated management port, the 1GE/10GE LOM ports, or a Cisco virtual interface card (VIC).</p> <p>CIMC manages certain components within the server, such as the Cisco 12G SAS HBA, when installed.</p>
Storage controllers	<p>Two 12G SAS HBAs plug into a dedicated slot.</p> <ul style="list-style-type: none"> <li>■ Cisco M6 12G SAS HBA:                             <ul style="list-style-type: none"> <li>• No RAID support</li> <li>• JBOD/Pass-through Mode support</li> <li>• Each HBA supports up to 16 SAS/SATA internal drives</li> </ul> </li> </ul>
Modular LAN on Motherboard (mLOM) slot	<p>The dedicated mLOM slot on the motherboard can flexibly accommodate the following cards:</p> <ul style="list-style-type: none"> <li>■ Cisco Virtual Interface Cards</li> </ul>
Intersight	Intersight provides server management capabilities
CIMC	Cisco Integrated Management Controller 4.2(3g) or later

## CONFIGURING the SERVER

Follow these steps to configure the HClAF240C M6 All-Flash Server:

- *STEP 1 VERIFY SERVER SKU, page 11*
- *STEP 2 SELECT MANAGMENT MODE (REQUIRED), page 12*
- *STEP 3 SELECT RISER CARDS (REQUIRED), page 13*
- *STEP 4 SELECT CPU(s), page 14*
- *STEP 5 SELECT MEMORY, page 18*
- *STEP 6 SELECT DRIVE CONTROLLERS, page 23*
- *STEP 7 SELECT DRIVES, page 24*
- *STEP 8 SELECT CISCO COMPUTE HYPERCONVERGED CONNECTIVITY (REQUIRED), page 26*
- *STEP 9 SELECT PCIe CARD(s) (OPTIONAL FOR FI MANAGED MODE), page 28*
- *STEP 10 ORDER GPU CARDS (OPTIONAL), page 31*
- *STEP 11 ORDER POWER SUPPLY, page 32*
- *STEP 12 SELECT INPUT POWER CORD(s), page 33*
- *STEP 13 ORDER TOOL-LESS RAIL KIT AND OPTIONAL REVERSIBLE CABLE MANAGEMENT ARM, page 37*
- *STEP 14 ORDER SECURITY DEVICES (OPTIONAL), page 38*
- *STEP 15 SELECT HYPERVISOR, page 39*
- *STEP 16 SELECT NUTANIX SOFTWARE AND NUTANIX PROFESSIONAL SERVICES, page 40*
- *STEP 17 CISCO INTERSIGHT (REQUIRED), page 86*

## STEP 1 VERIFY SERVER SKU

Table 2 PID of Major Line Bundle (MLB)

Product ID (PID)	Description
HCI-M6-MLB	Cisco Compute Hyperconverged M6 with Nutanix MLB This major line bundle (MLB) consists of the Cisco Compute Hyperconverged Server, with Intersight and Nutanix software PIDs.

Select one server product ID (PID) from [Table 3](#).

Table 3 PID of the HCIAF240C M6 All-Flash Server

Product ID (PID)	Description
HCIAF240C-M6SX <sup>1</sup> (All-Flash)	Cisco Compute Hyperconverged HCIAF240C M6 All-Flash Server <ul style="list-style-type: none"> <li>■ Includes 24 drive backplane.</li> <li>■ Front-loading drive bays 1–24 support 2.5-inch SAS/SATA drives.</li> <li>■ Does not include power supply, CPU, memory (DIMMs), Drives, SD cards, riser 1, riser 2, riser 3, tool-less rail kit, or PCIe cards.</li> </ul>

**Notes:**

1. This product may not be purchased outside of the approved bundles (must be ordered under the MLB).



**NOTE:** Use the steps on the following pages to configure the server with the components that you want to include.

## STEP 2 SELECT MANAGEMENT MODE (REQUIRED)

The available management modes are listed in [Table 4](#).

Table 4 Management Modes

Product ID (PID)	Description
HCI-FI-MANAGED-M6	Deployment mode for Server Managed by FI
HCI-IS-MANAGED-M6	Deployment mode for Standalone Server Managed by Intersight



### NOTE:

#### HCI Data Center with Fabric Interconnect:

- This deployment option connects the server to Cisco Fabric Interconnects operating in UCS Manager mode. The installation for this type of deployment is performed using the Nutanix Foundation VM.
- IMC standalone and Intersight Managed modes are not currently supported with this solution and UCS Manager with FIs must be used.
- UCS 4th Gen and 5th Gen fabric interconnects (6454, 64108, 6536) are supported with this solution
- If this deployment mode is selected, then HCI-MLOM from HCI Connectivity Mode must be selected from [STEP 8 SELECT CISCO COMPUTE HYPERCONVERGED CONNECTIVITY \(REQUIRED\), page 26](#) and additional cards should be selected from [STEP 9 SELECT PCIe CARD\(s\) \(OPTIONAL FOR FI MANAGED MODE\), page 28](#).

#### HCI with Intersight Standalone:

- This deployment option allows server nodes to be directly connected to existing Top of Rack (ToR) switches without the need for a pair of UCS Fabric Interconnects. The installation for this type of deployment must need Prism Central and Intersight.
- If this deployment mode is selected, then either HCI-MLOM or HCI-PCIE Connectivity Mode is must be selected from [STEP 8 SELECT CISCO COMPUTE HYPERCONVERGED CONNECTIVITY \(REQUIRED\), page 26](#)

### STEP 3 SELECT RISER CARDS (REQUIRED)

Select risers from [Table 5](#).

Table 5 PIDs of the Risers

Product ID (PID)	Description
HCI-RIS1A-240M6 (default riser)	C240 M6 Riser1A (controlled with CPU1) <ul style="list-style-type: none"> <li>■ PCIe Slot 1 (bottom slot): full height, 3/4 length, x8, NCSI</li> <li>■ PCIe Slot 2 (middle slot): full height, full length (GPU Card), x16, NCSI</li> <li>■ PCIe Slot 3 (top slot): full height, full length, x8</li> </ul>
UCSC-RIS2A-240M6 (default riser)	C240 M6 Riser2A (controlled with CPU2) <ul style="list-style-type: none"> <li>■ Slot 4 (bottom slot): full height, 3/4 length, x8, NCSI</li> <li>■ Slot 5 (middle slot): full height, full length (GPU Card), x16, NCSI</li> <li>■ Slot 6 (top slot): full height, full length, x8</li> </ul>
HCI-RIS3A-240M6 (default riser)	C240 M6 Riser3A (controlled with CPU2) <ul style="list-style-type: none"> <li>■ Slot 7 (bottom slot): full height, full length, x8</li> <li>■ Slot 8 (top slot): full height, full length, x8</li> </ul>
HCI-RIS3C-240M6 (GPU riser)	C240 M6 Riser 3C (controlled with CPU2) <ul style="list-style-type: none"> <li>■ Slot 7 supports one full-height, full-length, double-wide GPU (PCIe slot 7 only), x16</li> <li>■ Slot 8 blocked by double-wide GPU</li> </ul>



**NOTE:**

- Risers 1B and 3B are not supported in this solution. Only the 24 front facing drive slots can be populated with SSDs
- If there is any PCIe slot that does not have a card installed, you must order a blanking panel for that slot (UCSC-FBRS2-C240M6 = for riser 2 and UCSC-FBRS3-C240M6= for riser 3).

For additional details, see [Riser Card Configuration and Options, page 98](#).

## STEP 4 SELECT CPU(s)

The standard CPU features are:

- 3rd Gen Intel® Xeon® Scalable Processors (Ice Lake)
- Intel® C621A series chipset
- Cache size of up to 60 MB
- Up to 40 cores

### Select CPUs

The available CPUs are listed in [Table 6](#)

Table 6 Available CPUs

Product ID (PID)	Clock Freq (GHz)	Power (W)	Cache Size (MB)	Cores	UPI <sup>1</sup> Links (GT/s)	Highest DDR4 DIMM Clock Support (MHz) <sup>2</sup>
<b>8000 Series Processors</b>						
HCI-CPU-I8380	2.3	270	60	40	3 at 11.2	3200
HCI-CPU-I8368	2.4	270	57	38	3 at 11.2	3200
HCI-CPU-I8362	2.8	265	48	32	3 at 11.2	3200
HCI-CPU-I8360Y	2.4	250	54	36	3 at 11.2	3200
HCI-CPU-I8358P	2.6	240	48	32	3 at 11.2	3200
HCI-CPU-I8358	2.6	250	48	32	3 at 11.2	3200
HCI-CPU-I8352Y	2.2	205	48	32	3 at 11.2	3200
HCI-CPU-I8352V	2.1	195	54	36	3 at 11.2	2933
HCI-CPU-I8352M	2.3	185	48	32	3 at 11.2	2933
HCI-CPU-I8352S	2.2	205	48	32	3 at 11.2	3200
HCI-CPU-I8351N <sup>3</sup>	2.4	225	54	36	0	2933
<b>6000 Series Processors</b>						
HCI-CPU-I6354	3.0	205	39	18	3 at 11.2	3200
HCI-CPU-I6348	2.6	235	42	28	3 at 11.2	3200
HCI-CPU-I6346	3.1	205	36	16	3 at 11.2	3200
HCI-CPU-I6342	2.8	230	36	24	3 at 11.2	3200
HCI-CPU-I6338N	2.2	185	48	32	3 at 11.2	2666
HCI-CPU-I6338T	2.1	165	36	24	3 at 11.2	3200
HCI-CPU-I6338	2.0	205	48	32	3 at 11.2	3200
HCI-CPU-I6336Y	2.4	185	36	24	3 at 11.2	3200
HCI-CPU-I6334	3.6	165	18	8	3 at 11.2	3200
HCI-CPU-I6330N	2.2	165	42	28	3 at 11.2	2666

Table 6 Available CPUs

Product ID (PID)	Clock Freq (GHz)	Power (W)	Cache Size (MB)	Cores	UPI <sup>1</sup> Links (GT/s)	Highest DDR4 DIMM Clock Support (MHz) <sup>2</sup>
HCI-CPU-I6330	2.0	205	42	28	3 at 11.2	2933
HCI-CPU-I6326	2.9	185	24	16	3 at 11.2	3200
HCI-CPU-I6314U <sup>4</sup>	2.3	205	48	32	0	3200
HCI-CPU-I6312U <sup>5</sup>	2.4	185	36	24	0	3200
<b>5000 Series Processors</b>						
HCI-CPU-I5320T	2.3	150	30	20	3 at 11.2	2933
HCI-CPU-I5320	2.2	185	39	26	3 at 11.2	2933
HCI-CPU-I5318N	2.1	150	36	24	3 at 11.2	2666
HCI-CPU-I5318S	2.1	165	36	24	3 at 11.2	2933
HCI-CPU-I5318Y	2.1	165	36	24	3 at 11.2	2933
HCI-CPU-I5317	3.0	150	18	12	3 at 11.2	2933
HCI-CPU-I5315Y	3.2	140	12	8	3 at 11.2	2933
<b>4000 Series Processors</b>						
HCI-CPU-I4316	2.3	150	30	20	2 at 10.4	2666
HCI-CPU-I4314	2.4	135	24	16	2 at 10.4	2666
HCI-CPU-I4310T	2.3	105	15	10	2 at 10.4	2666
HCI-CPU-I4310	2.1	120	18	12	2 at 10.4	2666
HCI-CPU-I4309Y	2.8	105	12	8	2 at 10.4	2666

**Notes:**

1. UPI = Ultra Path Interconnect.
2. If higher or lower speed DIMMs are selected than what is shown in [Table 8 on page 19](#) for a given CPU speed, the DIMMs will be clocked at the lowest common denominator of CPU clock and DIMM clock.
3. The maximum number of HCI-CPU-I8351N CPUs is one
4. The maximum number of HCI-CPU-I6314U CPUs is one
5. The maximum number of HCI-CPU-I6312U CPUs is one



**CAUTION:** For systems configured with 3rd Gen Intel® Xeon® Scalable Processors (Ice Lake) operating above 28° C [82.4° F], a fan fault or executing workloads with extensive use of heavy instructions sets such as Intel® Advanced Vector Extensions 512 (Intel® AVX-512), may assert thermal and/or performance faults with an associated event recorded in the System Event Log (SEL).

If an NVIDIA A10 or A100 GPU is installed or rear HDDs are installed, the 28° C [82.4° F] restriction changes to 25° C [77° F]



Table 7 CPU Suffixes

CPU Suffix	Description	Features
N	Networking Optimized	Optimized for use in networking applications like L3 forwarding, 5G UPF, OVS DPDK, VPP FIB router, VPP IPsec, web server/NGINX, vEPC, vBNG, and vCMTS. SKUs have higher base frequency with lower TDPs to enable best performance/Watt
P	Cloud Optimized	SKU specifically designed for cloud IaaS environments to deliver higher frequencies at constrained TDPs
V	Cloud Optimized	SKUs specifically designed for cloud environments to deliver high rack density and maximize VM/cores per TCO\$
T	High T case	SKUs designed for Network Environment-Building System (NEBS) environments
U	1-socket Optimized	Optimized for targeted platforms adequately served by the cores, memory bandwidth and IO capacity available from a single processor
S	Max SGX enclave size	Supports Max SGX enclave size (512GB) to enhance and protect the most sensitive portions of a workload or service
M	Media and AI optimized	Media, AI and HPC Segment Optimized for lower TDP & higher frequencies delivering better perf/w
Y	Speed Select - Performance Profile	Intel® Speed Select Technology provides the ability to set a guaranteed base frequency for a specific number of cores, and assign this performance profile to a specific application/workload to guarantee performance requirements. It also provides the ability to configure settings during runtime and provide additional frequency profile configuration opportunities.

## Supported Configurations

---

### (1) One-CPU Configuration:

- Choose one CPU from any one of the rows of [Table 6 Available CPUs, page 14](#)

### (2) Two-CPU Configuration:

- Choose two identical CPUs from any one of the rows of [Table 6 Available CPUs, page 14](#)



#### NOTE:

- You cannot have two I8351N or two I6314U or I6312U CPUs in a two-CPU configuration.
  - If you configure a server with one I8351N CPU or one I6314U CPU or one I6312U CPU you cannot later upgrade to a 2-CPU system with two of these CPUs.
-

## STEP 5 SELECT MEMORY

The available memory main characteristics for the HCIAF240C M6 All-Flash Server are as follows:

- Clock speed: 3200 MHz
- Ranks per DIMM: 1, 2, 4, or 8
- Operational voltage: 1.2 V
- Registered ECC DDR4 DIMMS (RDIMMs), Load-reduced DIMMS (LRDIMMs),

Memory is organized with eight memory channels per CPU, with up to two DIMMs per channel, as shown in *Figure 4*.

Figure 4 HCIAF240C M6 All-Flash Server Memory Organization

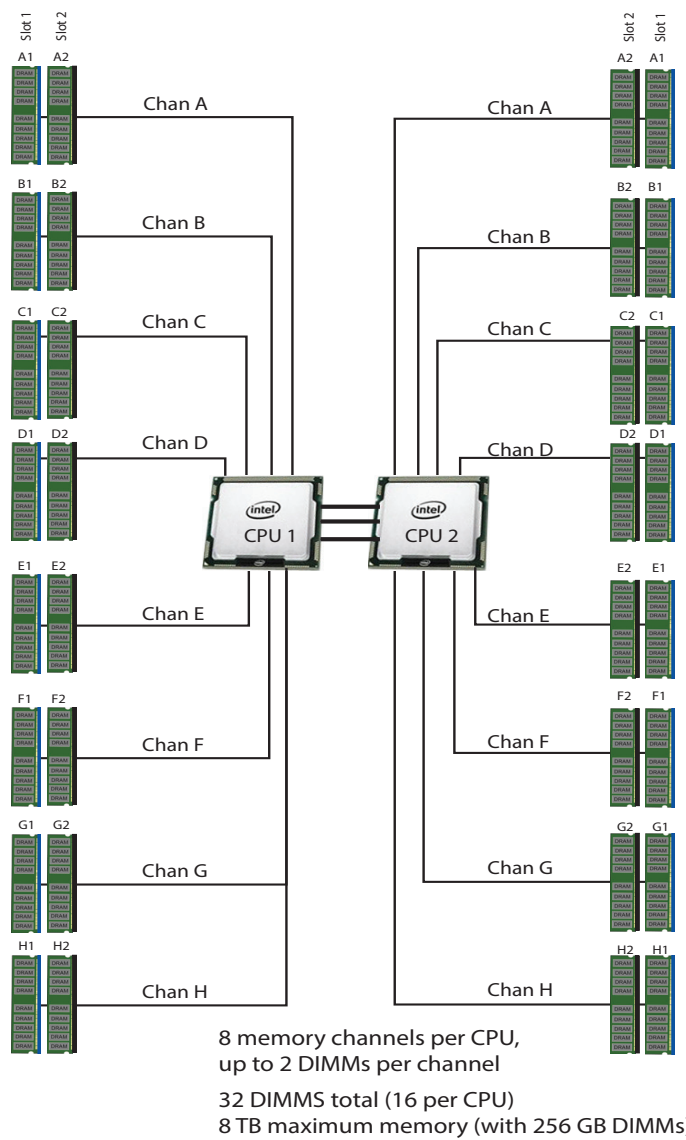

## Select DIMMs

The available memory DIMMs option are listed in [Table 8](#).

**Table 8 Available DDR4 DIMMs**

Product ID (PID)	PID Description	Voltage	Ranks /DIMM
<b>3200-MHz DIMMs</b>			
HCI-MR-X16G1RW	16GB RDIMM SRx4 3200 (8Gb)	1.2 V	1
HCI-MR-X32G1RW	32GB RDIMM SRx4 3200 (16Gb)	1.2 V	1
HCI-MR-X32G2RW	32GB RDIMM DRx4 3200 (8Gb)	1.2 V	2
HCI-MR-X64G2RW	64GB RDIMM DRx4 3200 (16Gb)	1.2 V	2
HCI-ML-128G4RW	128GB LRDIMM QRx4 3200 (16Gb) (non 3DS)	1.2 V	4
HCI-ML-256G8RW <sup>1</sup>	256GB LRDIMM 8Rx4 3200 (16Gb) (3DS)	1.2 V	8
<b>DIMM Blank<sup>2</sup></b>			
UCS-DIMM-BLK	UCS DIMM Blank		

**Notes:**

- 256GB DIMMs cannot be combined with GPU cards, and the ambient temperature shall be limited to a maximum of 28°C.
- Any empty DIMM slot must be populated with a DIMM blank to maintain proper cooling airflow.



**NOTE:**

- System performance is optimized when the DIMM type and quantity are equal for both CPUs, and when all channels are filled equally across the CPUs in the server.
- The selected DIMMs must be all of same type and number of DIMMs must be equal for both CPUs

## Memory Configurations, Features, and Modes

System speed is dependent on the CPU DIMM speed support. Refer to [Available CPUs, page 14](#) for DIMM speeds.

- The server supports the following memory reliability, availability, and serviceability (RAS) BIOS options (only one option can be chosen):
  - Adaptive Double Device Data Correction (ADDDC) (default)
  - Maximum performance
- For best performance, observe the following:
  - When one DIMM is used, it must be populated in DIMM slot 1 (farthest away from the CPU) of a given channel.
  - When single- or dual-rank DIMMs are populated in two DIMMs per channel (2DPC) configurations, always populate the higher number rank DIMM first (starting from

the farthest slot). For a 2DPC example, first populate with dual-rank DIMMs in DIMM slot 1. Then populate single-rank DIMMs in DIMM 2 slot.

- DIMMs for CPU 1 and CPU 2 (when populated) must always be configured identically.
- Cisco memory from previous generation servers (DDR3 and DDR4) is not compatible with the server.
- Memory can be configured in any number of DIMMs as pairs, although for optimal performance, see the following document  
[UCS M6 Memory Guide](#)

## Approved Configurations

### (1) 1-CPU configuration:

- Select from 1 to 16 DIMMs
  - 1, 2, 4, 6, 8, 12, or 16 DIMMs allowed
  - 3, 5, 7, 9, 10, 11, 13, 14, 15 DIMMs not allowed
  - DIMMs for both CPUs must be configured identically.

The DIMMs will be placed by the factory as shown in the following table.

#DIMMs	CPU 1 DIMM Placement in Channels (for identically ranked DIMMs)
1	(A1)
2	(A1, E1)
4	(A1, C1); (E1, G1)
6	(A1, C1); (D1, E1); (G1, H1)
8	(A1, C1); (D1, E1); (G1, H1); (B1, F1)
12	(A1, C1); (D1, E1); (G1, H1); (A2, C2); (D2, E2); (G2, H2)
16	(A1, B1); (C1, D1); (E1, F1); (G1, H1); (A2, B2); (C2, D2); (E2, F2); (G2, H2)

### (2) 2-CPU configuration:

- Select from 1 to 16 DIMMs per CPU
  - 1, 2, 4, 6, 8, 12, or 16 DIMMs allowed
  - 3, 5, 7, 9, 10, 11, 13, 14, 15 DIMMs not allowed
  - DIMMs for both CPUs must be configured identically.

The DIMMs will be placed by the factory as shown in the following table.

#DIMMs	CPU 1 DIMM Placement in Channels (for identically ranked DIMMs)	CPU 2 DIMM Placement in Channels (for identically ranked DIMMs)
1	(A1)	(A1)
2	(A1, E1)	(A1, E1)
4	(A1, C1); (E1, G1)	(A1, C1); (E1, G1)
6	(A1, C1); (D1, E1); (G1, H1)	(A1, C1); (D1, E1); (G1, H1)
8	(A1, C1); (D1, E1); (G1, H1); (B1, F1)	(A1, C1); (D1, E1); (G1, H1); (B1, F1)
12	(A1, C1); (D1, E1); (G1, H1); (A2, C2); (D2, E2); (G2, H2)	(A1, C1); (D1, E1); (G1, H1); (A2, C2); (D2, E2); (G2, H2)
16	(A1, B1); (C1, D1); (E1, F1); (G1, H1); (A2, B2); (C2, D2); (E2, F2); (G2, H2)	(A1, B1); (C1, D1); (E1, F1); (G1, H1); (A2, B2); (C2, D2); (E2, F2); (G2, H2)



**NOTE:** System performance is optimized when the DIMM type and quantity are equal for both CPUs, and when all channels are filled equally across the CPUs in the server.

**Table 9 3200-MHz DIMM Memory Speeds with Different Intel® Xeon® Ice Lake® Processors**

DIMM and CPU Frequencies (MHz)	DPC	LRDIMM (8Rx4)-256GB (MHz)	LRDIMM (4Rx4)-128GB (MHz)	RDIMM (2Rx4) - 64GB (MHz)	RDIMM (2Rx4) - 32GB (MHz)	RDIMM (1Rx4) - 16GB (MHz)
		1.2 V	1.2 V	1.2 V	1.2 V	1.2 V
DIMM = 3200 CPU = 3200	1DPC	3200	3200	3200	3200	3200
	2DPC	3200	3200	3200	3200	3200
DIMM = 3200 CPU = 2933	1DPC	2933	2933	2933	2933	2933
	2DPC	2933	2933	2933	2933	2933
DIMM = 3200 CPU = 2666	1DPC	2666	2666	2666	2666	2666
	2DPC	2666	2666	2666	2666	2666

**DIMM Rules**

- Allowed DIMM count for 1 CPU:
  - Minimum DIMM count = 1; Maximum DIMM count = 16
  - 1, 2, 4, 6, 8, 12, or 16 DIMMs allowed
  - 3, 5, 7, 9, 10, 11, 13, 14, or 15 DIMMs not allowed.
- Allowed DIMM count for 2 CPUs:
  - Minimum DIMM count = 2; Maximum DIMM count = 32
  - 2, 4, 8, 12, 16, 24, or 32 DIMMs allowed
  - 6, 10, 14, 18, 20, 22, 26, 28, or 30 DIMMs not allowed.
- DIMM Mixing:
  - Mixing different types of DIMM (RDIMM with any type of LRDIMM or 3DS LRDIMM with non-3DS LRDIMM) is not supported within a server.
  - Mixing RDIMM with RDIMM types is allowed if they are mixed in same quantities, in a balanced configuration.
  - Mixing 16GB, 32GB, and 64GB RDIMMs is supported.
  - 128GB and 256GB LRDIMMs cannot be mixed with other RDIMMs
  - 128GB non-3DS LRDIMMs cannot be mixed with 256GB 3DS LRDIMMs

## STEP 6 SELECT DRIVE CONTROLLERS

The following list summarizes how drives are controlled on the server:

- SAS/SATA drives are controlled through two Cisco 12G SAS pass-through HBAs.
- PCIe/NVMe drives are not supported in HClAF240C M6.

### Cisco 12G SAS HBA

This HBA supports up to 16 SAS or SATA drives operating at 3GBs, 6GBs, and 12Gbs. It supports JBOD or pass-through mode (not RAID) and plugs directly into the drive backplane. Two of these controllers are required to control 24 front drives.

#### Select Drive Controller Options

Select the following:

- Cisco 12G SAS HBA (see [Table 10](#)).

**Table 10 Hardware Controller Options**

Product ID (PID)	PID Description
<b>Controllers for Internal Drives</b>	
<b>Note that if a Cisco 12G SAS HBA is selected, it is factory-installed in the drive backplane connector.</b>	
HCl-SAS-240M6 <sup>1</sup>	Cisco 12G SAS HBA <ul style="list-style-type: none"> <li>■ Supports up to 16 internal SAS/SATA SSDs</li> <li>■ Supports JBOD or pass-through mode</li> </ul>

**Notes:**

1. Two of these controllers are required to control 24 front drives.



## STEP 7 SELECT DRIVES

The standard disk drive features are:

- 2.5-inch small form factor
- Hot-pluggable
- Drives come mounted in sleds

### Select Drives - HCIAF240C-M6SX (All-Flash)

The available drives are listed in [Table 11](#).



**NOTE:** Nutanix AOS supports a maximum of 216TB raw capacity per node.

**Table 11 Available Hot-Pluggable Sled-Mounted Drives**

Product ID (PID)	PID Description	Drive Type	Capacity
<b>Front Capacity Drive</b>			
HCI-SD19T6S1XEVM6	1.9TB 2.5 inch Enterprise Value 6G SATA SSD	SATA	1.9TB
HCI-SD38T6S1XEVM6	3.8TB 2.5 inch Enterprise Value 6G SATA SSD	SATA	3.8TB
HCI-SD38T6I1XEVM6	3.8TB 2.5in Enter Value 6G SATA Intel SSD	SATA	3.8TB
HCI-SD76T6S1XEVM6	7.6TB 2.5 inch Enterprise Value 6G SATA SSD	SATA	7.6TB
HCI-SD38TKA1XEVM6	3.8TB 2.5 inch Enterprise Value 12G SAS SSD	SAS	3.8TB
HCI-SD76TKA1XEVM6	7.6TB 2.5 inch Enterprise Value 12G SAS SSD	SAS	7.6TB
HCI-SD15TKA1XEVM6	15.3TB 2.5in Enter Value 12G SAS Kioxia G2 SSD	SAS	15.3TB
<b>Front SED Capacity Drive</b>			
HCI-SD38TBKNK9-M6	3.8TB Enterprise Value SAS SSD (1X FWPD, SED)	SAS	3.8TB
HCI-SD76TBKNK9-M6	7.6TB Enterprise value SAS SSD (1 DWPD, SED-FIPS)	SAS	7.6TB
HCI-SD38TBKANK9M6	3.8TB 2.5in Enterprise value 12G SAS SSD (1DWPD, SED-FIPS)	SAS	3.8TB
HCI-SD76TBKANK9M6	7.6TB Enterprise value SAS SSD (1 DWPD, SED-FIPS)	SAS	7.6TB
<b>Boot Drive</b>			
HCI-M2-240G-M6	240GB M.2 SATA SSD	SATA	240GB
HCI-M2-I240GB-M6	240GB M.2 SATA SSD	SATA	240GB
HCI-M2-HWRAID-M6	Cisco Boot optimized M.2 Raid controller		

Table 11 Available Hot-Pluggable Sled-Mounted Drives (*continued*)

Product ID (PID)	PID Description	Drive Type	Capacity
<p><b>NOTE:</b> Cisco uses solid state drives (SSDs) from a number of vendors. All solid state drives (SSDs) are subject to physical write limits and have varying maximum usage limitation specifications set by the manufacturer. Cisco will not replace any solid state drives (SSDs) that have exceeded any maximum usage specifications set by Cisco or the manufacturer, as determined solely by Cisco.</p>			

### Approved Configurations

---

- Two to twenty four capacity drives.
- Two boot drives with M.2 Raid controller



#### NOTE:

- Dual M.2 SATA SSD with the HW RAID controller is the only supported boot configuration for this solution.
- The Boot-Optimized RAID controller supports AHV and VMware Operating Systems.
- UCSM is supported for configuring of volumes and monitoring of the controller and installed SATA M.2 drives.
- The SATA M.2 drives can boot in UEFI mode only. Legacy boot mode is not supported.
- Hot-plug replacement is not supported. The server must be powered off.
- See [Figure 8 on page 94](#) for the location of the module connector on the motherboard. This connector accepts the boot-optimized RAID controller.

### Caveats

---

- SED drives can not be mixed with the non-SED drives.

## STEP 8 SELECT CISCO COMPUTE HYPERCONVERGED CONNECTIVITY (REQUIRED)

### A. FI Managed Mode - HCI connectivity:

The following connectivity and cards options are available, if you select the FI Managed Mode from the [STEP 2 SELECT MANAGEMENT MODE \(REQUIRED\)](#).

#### Select Connectivity

The available connectivity are listed in [Table 12](#).



**NOTE:**

- HCI MLOM Connectivity (HCI-MLOM) is mandatory for this solution.
- Minimum and maximum one MLOM card is available from the [Table 13](#).
- Supported configuration maximum is Single MLOM + Single VIC (select VIC under the riser PCIe VIC card option from [Table 16](#)).
- Additional NIC cards can be selected for user VM network traffic and will be directly connected to ToR (top of the rack), select NIC under the riser PCIe NIC options [Table 16](#).

**Table 12 Cisco Compute Hyperconverged Connectivity**

Product ID (PID)	Description	Max cards available per node	Requirement
HCI-MLOM-M6	Cisco VIC Connectivity	1	1 mLOM (Mandatory) + 1 PCIe VIC (optional) (select from <a href="#">Table 13</a> )

The available cards for the Cisco Compute Hyperconverged MLOM are listed in [Table 13](#)

**Table 13 Available Cards for the Cisco Compute Hyperconverged MLOM Connectivity**

Product ID (PID)	Description	Location	Card Size <sup>1</sup>
<b>MLOM Cards</b>			
HCI-M-V25-04	Cisco UCS VIC 1467 quad port 25G SFP28 mLOM	mLOM	HHHL, SS

**Notes:**

1. HHHL = half-height, half-length; FHHL = full-height, half-length; SS = single-slot; DS = double-slot. SFF = small form factor.

## B. Intersight Standalone Mode (IS Managed) - HCI connectivity:



**Golden Rule:** Mixing VIC and NIC in same server/cluster is not supported.

The following connectivity options are available, if you select the Intersight Standalone Mode (IS Managed) from the **STEP 2 SELECT MANAGEMENT MODE (REQUIRED)**.

### Select Connectivity

The available connectivity are listed in [Table 14](#).



#### NOTE:

- Either Cisco VIC Connectivity (HCI-MLOM) or Third Party NIC Connectivity (HCI-PCIE) is mandatory for this solution.
- Use HCI-MLOM for VIC based connectivity and HCI-PCIE for NIC based connectivity.
- Minimum and maximum **one** MLOM card is available from the [Table 14](#).
- When HCI-MLOM is selected up to three additional VIC can be selected from the [Table 16](#).
- When HCI-PCIE is selected up to two additional NIC can be selected from the table [Table 16](#).

**Table 14 Cisco Compute Hyperconverged Connectivity**

Product ID (PID)	Description	Max cards available per node	Requirement (Either HCI-MLOM or HCI-PCIE is Mandatory)
HCI-MLOM-M6	Cisco VIC Connectivity	1 MLOM VIC + 2 PCIe VIC	Select from MLOM VIC <a href="#">Table 15</a> and additional VIC in the riser slot from the <a href="#">Table 16</a>
HCI-PCIE-M6	Third Party NIC Connectivity	3 dual port or 3 quad port in PCIe riser slot	Select NIC cards under riser from <a href="#">Table 16</a>

The available cards for the MLOM connectivity are listed in [Table 15](#).

**Table 15 Available Cards for the Cisco Compute Hyperconverged MLOM Connectivity**

Product ID (PID)	Description	Location	Card Size <sup>1</sup>
<b>MLOM Cards</b>			
HCI-M-V25-04	Cisco UCS VIC 1467 quad port 25G SFP28 mLOM	mLOM	HHHL, SS

**Notes:**

1. HHHL = half-height, half-length; FHHL = full-height, half-length; SS = single-slot; DS = double-slot. SFF = small form factor.

## STEP 9 SELECT PCIe CARD(s) (OPTIONAL FOR FI MANAGED MODE)

For up-to-date server compatibility, please check the Hardware and Software compatibility list (HCL) at <https://ucshcltool.cloudapps.cisco.com/public/>.

The standard PCIe card offerings are:

- Virtual Interface Cards (VICs)
- Network Interface Cards (NICs)



**NOTE:** In FI managed mode additional 3rd party NIC cards can be selected. These are for **User VM traffic** only, i.e these can act as uplink ports for vSwitches to carry user VM network traffic. These NICs are directly connected to the Top-Of-Rack Switch and Cannot be connected to Fabric interconnect

### Select Option Cards

The available option cards are listed in [Table 16](#)

**Table 16 Available PCIe Option Cards**

Product ID (PID)	PID Description	Location	Card Size <sup>1</sup>	Supported Management Mode
<b>Virtual Interface Cards (VICs)</b>				
HCI-PCIE-C25Q-04	Cisco UCS VIC 1455 Quad Port 10/25G SFP28 CNA PCIE	Riser 1 or 2	HHHL, SS	IS Managed Mode FI Managed Mode
<b>Network Interface Cards (NICs)</b>				
<b>10GbE NICs</b>				
HCI-P-ID10GC-M6	Cisco-Intel X710T2LG 2x10GBE RJ45 PCIe NIC	Riser 1, 2, or 3	HHHL, SS	FI Managed Mode (User VM traffic only)
HCI-P-IQ10GC-M6	Cisco-Intel X710T4LG 4x10GBE RJ45 PCIe NIC	Riser 1, 2, or 3	HHHL, SS	FI Managed Mode (User VM traffic only)
<b>25GbE NICs</b>				
HCI-P-I8D25GF-M6 <sup>2</sup>	Cisco-Intel E810XXVDA2 2x25/10GBE SFP28 PCIe NIC	Riser 1, 2, or 3	HHHL, SS	IS Managed Mode FI Managed Mode (User VM traffic only)
HCI-P-I8Q25GF-M6 <sup>3</sup>	Cisco-Intel E810XXVDA4L 4x25/10GBE SFP28 PCIe NIC	Riser 1, 2, or 3	FHHL, SS	IS Managed Mode FI Managed Mode (User VM traffic only)
<b>100GbE NICs</b>				
HCI-P-I8D100GF-M6 <sup>3,4</sup>	Cisco-Intel E810CQDA2 2x100 GbE QSFP28 PCIe NIC	Riser 1, 2, or 3	HHHL, SS	FI Managed Mode (User VM traffic only)

**Notes:**

1. HHHL = half-height, half-length; FHHL = full-height, half-length; SS = single-slot; DS = double-slot. SFF = small form factor.
2. When present, the recommended Fan Speed Control policy setting is balanced.

**Caveats**

- For 1-CPU systems:
  - Only PCIe slots 1, 2, and 3 on PCIe riser 1A are available for a 1-CPU system.
  - The PCIe slots on riser 2 are not supported on 1-CPU systems. The riser 2 slots are full-height PCIe slots 4, 5, and 6 (see [Figure 3 on page 6](#)). These are the slots in the middle when looking at the rear of the server. Slot 4 is the bottom slot.
  - The PCIe slots on riser 3 are not supported on 1-CPU systems. The riser 3 slots are full-height PCIe slots 7 and 8 (see [Figure 3 on page 6](#)). These are the slots on the right when looking at the rear of the server. Slot 7 is the bottom slot.
  - Only a single plug-in PCIe VIC card is supported and must be installed in slot 2 in addition to the one mandatory mLOM VIC card installed in the mLOM slot. If you order a double-width GPU, it must be installed in slot 2; then a PCIe VIC can be installed in slot 1. See [Table 17 on page 31](#). See [Table 16 on page 28](#) for the selection of plug-in and mLOM VIC cards. See also [Table 1 on page 8](#) and [HCIAF240C M6 All-Flash Server Riser Connector Locations](#) for the PCIe slot physical descriptions.
- For 2-CPU systems:
  - The following PCIe slots are available:
    - Three on PCIe riser 1A (PCIe slots 1, 2, and 3),
    - Three on PCIe riser 2A (PCIe slots 4, 5, and 6),
    - Two on PCIe riser 3A (PCIe slots 7 and 8).
  - You must order an mLOM VIC card to be installed in the mLOM slot internal to the chassis. You can also have PCIe VICs in slot 2 and slot 5 and thus have two PCIe VICs and one mLOM VIC in operation at the same time. If you order a double width GPU, it must be installed in slots 2, 4 or 7; then two PCIe VIC can be installed in slot 1 and slot 4. See [Table 16 on page 28](#) for the selection of plug-in and mLOM VIC cards. See also [Table 1 on page 8](#) and [HCIAF240C M6 All-Flash Server Riser Connector Locations](#) for the PCIe slot physical descriptions.
  - If GPUs are installed in slot 2 of riser 1A or slot 5 of riser 2A, the NCSI capability automatically switches over to slot 1 of riser 1A or slot 4 of Riser 2A. Therefore, Cisco PCIe VICs can be installed in slots 1 and 4 if GPUs are installed in slots 2 and 5. If you order multiple GPUs, they must be installed as shown in [Table 17 on page 31](#).
  - The server supports up to four PCIe Cisco VICs plus an MLOM VIC
 

However, single wire management is supported on only one VIC at a time. If multiple VICs are installed on a server, only one slot has NCSI enabled at a time and for single wire management, priority goes to the MLOM slot, then slot 2, then slot 5

for NCSI management traffic. When multiple cards are installed, connect the single wire management cables in the priority order mentioned above.

<https://ucshcltool.cloudapps.cisco.com/public/>

## ORDER OPTIONAL PCIe OPTION CARD ACCESSORIES

- For list of supported optics and cables for VIC 1455 refer to the VIC 1400 series data sheets at the following link:
  - <https://www.cisco.com/c/en/us/products/collateral/interfaces-modules/unified-computing-system-adapters/datasheet-c78-741130.html>
- The information in the preceding tables was compiled from testing conducted by Cisco Transceiver Module Group (TMG) and vendors. The latest compatibility with optical modules and DACs can be found at <https://tmgmatrix.cisco.com/>.

## STEP 10 ORDER GPU CARDS (OPTIONAL)



**NOTE:** When a GPU is ordered, the server comes with low-profile heatsinks PID (HCI-HSLP-M6=) and need to select special air duct PID (HCI-ADGPU-245M6=) for double-wide GPUs.

### Select GPU Options

The available GPU PCIe options and their riser slot compatibilities are listed in [Table 17](#)

Table 17 Available PCIe GPU Cards<sup>1</sup>

GPU Product ID (PID)	PID Description	Card Size	Max GPU per Node	Riser Slot Compatibility			
				Riser 1A (Gen 4)	Riser 2 (Gen 4)	Riser 3A <sup>2</sup> (Gen 4)	Riser 3C <sup>3</sup>
HCI-GPU-A10-M6	TESLA A10, PASSIVE, 150W, 24GB	Single-wide	5	slot 2&3	slot 5&6	N/A	slot 7
HCI-GPU-A30-M6	TESLA A30, PASSIVE, 180W, 24GB	Double-wide	3	slot 2	slot 5	N/A	slot 7
HCI-GPU-A40-M6	TESLA A40 RTX, PASSIVE, 300W, 48GB	Double-wide	3	slot 2	slot 5	N/A	slot 7
HCI-GPU-A100-80-M6	TESLA A100, PASSIVE, 300W, 80GB	Double-wide	3	slot 2	slot 5	N/A	slot 7
HCI-GPU-A16-M6	NVIDIA A16 PCIE 250W 4X16GB	Double-wide	3	slot 2	slot 5	N/A	slot 7

**Notes:**

1. Refer to [installation guide](#) for the GPU related information
2. Riser 3A does not accept GPUs
3. The server supports one full-height, full-length, double-wide GPU (PCIe slot 7 only) in Riser 3C.



**NOTE:**

- All GPU cards must be procured from Cisco as there is a unique SBIOS ID required by CIMC and UCSM.
- If you are adding GPUs later, accessories/cables needed along with the GPU spare.
- GPUs cannot be mixed.



## STEP 11 ORDER POWER SUPPLY

Power supplies share a common electrical and physical design that allows for hot-plug and tool-less installation into M6 HCI-Series servers. Each power supply is certified for high-efficiency operation and offer multiple power output options. This allows users to “right-size” based on server configuration, which improves power efficiency, lower overall energy costs and avoid stranded capacity in the data center. Use the power calculator at the following link to determine the needed power based on the options chosen (CPUs, drives, memory, and so on):

<http://ucspowercalc.cisco.com>



**WARNING:**

- Starting 1st January 2024, only Titanium rated PSUs are allowed to be shipped to European Union (EU), European Economic Area (EEA), United Kingdom (UK), Switzerland and other countries that adopted Lot 9 Regulation.
- DC PSUs are not impacted by Lot 9 Regulation and are EU/UK Lot 9 compliant

Table 18 Power Supply

Product ID (PID)	PID Description
<b>PSU (Input High Line 210VAC)</b>	
HCI-PSU1-1050W-M6	UCS 1050W AC PSU Platinum (Not EU/UK Lot 9 Compliant)
HCI-PSUV21050DCM6 <sup>1</sup>	1050W DC power supply for Rack servers <b>Platinum</b>
HCI-PSU1-1200W-M6	1200W Titanium power supply for C-Series Servers
HCI-PSU1-1600W-M6	UCS 1600W AC PSU Platinum (Not EU/UK Lot 9 Compliant)
HCI-PSU1-2300W-M6 <sup>2</sup>	2300W Power supply for Rack servers <b>Titanium</b>
<b>PSU (Input Low Line 110VAC)</b>	
HCI-PSU1-1050W-M6	UCS 1050W AC PSU Platinum (Not EU/UK Lot 9 Compliant)
HCI-PSUV21050DCM6 <sup>1</sup>	1050W DC power supply for Rack servers <b>Platinum</b>
HCI-PSU1-1200W-M6	1200W Titanium power supply for C-Series Servers
HCI-PSU1-2300W-M6	2300W Power supply for Rack servers <b>Titanium</b>

**Notes:**

1. DC PSUs are not impacted by Lot 9 Regulation and are EU/UK Lot 9 compliant
2. The 2300 W power supply uses a different power connector than the rest of the power supplies, so you must use different power cables to connect it. See [Table 19 on page 33](#) and [Table 20 on page 36](#).



**NOTE:** In a server with two power supplies, both power supplies must be identical.

## STEP 12 SELECT INPUT POWER CORD(S)

Using [Table 19](#) and [Table 20](#), select the appropriate AC power cords. You can select a minimum of no power cords and a maximum of two. If you select the option R2XX-DMYPWRCORD, no power cord is shipped with the server.



**NOTE:** [Table 19](#) lists the power cords for servers that use power supplies less than 2300 W. [Table 20](#) lists the power cords for servers that use 2300 W power supplies. Note that the power cords for 2300 W power supplies use a C19 connector so they only fit the 2300 W power supply connector.

**Table 19 Available Power Cords (for server PSUs less than 2300 W)**

Product ID (PID)	PID Description	Images
NO-POWER-CORD	ECO friendly green option, no power cable will be shipped	
CAB-48DC-40A-8AWG	C-Series -48VDC PSU Power Cord, 3.5M, 3 Wire, 8AWG, 40A	
CAB-N5K6A-NA	Power Cord, 200/240V 6A, North America	
CAB-AC-L620-C13	AC Power Cord, NEMA L6-20 - C13, 2M/6.5ft	
CAB-C13-CBN	CABASY,WIRE,JUMPER CORD, 27" L, C13/C14, 10A/250V	
CAB-C13-C14-2M	CABASY,WIRE,JUMPER CORD, PWR, 2 Meter, C13/C14,10A/250V	

Table 19 Available Power Cords (for server PSUs less than 2300 W)

Product ID (PID)	PID Description	Images
CAB-C13-C14-AC	CORD,PWR,JMP,IEC60320/C14,IEC60320/C13, 3.0M	
CAB-250V-10A-AR	Power Cord, 250V, 10A, Argentina	
CAB-9K10A-AU	Power Cord, 250VAC 10A 3112 Plug, Australia	
CAB-250V-10A-CN	AC Power Cord - 250V, 10A - PRC	
CAB-9K10A-EU	Power Cord, 250VAC 10A CEE 7/7 Plug, EU	
CAB-250V-10A-ID	Power Cord, 250V, 10A, India	
CAB-C13-C14-3M-IN	Power Cord Jumper, C13-C14 Connectors, 3 Meter Length, India	Image not available
CAB-C13-C14-IN	Power Cord Jumper,C13-C14 Connectors,1.4 Meter Length, India	Image not available
CAB-250V-10A-IS	Power Cord, SFS, 250V, 10A, Israel	

Table 19 Available Power Cords (for server PSUs less than 2300 W)

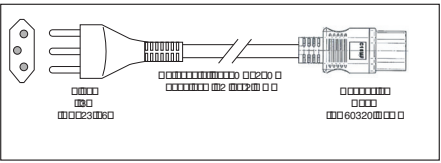
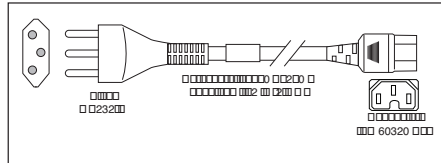
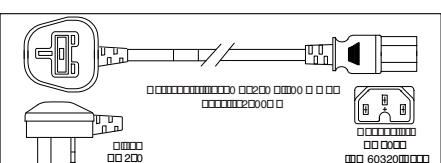
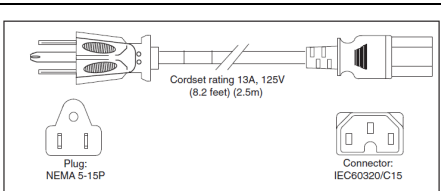
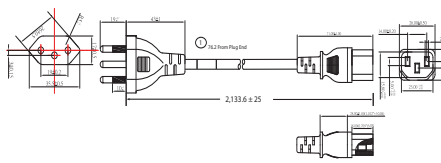
Product ID (PID)	PID Description	Images
CAB-9K10A-IT	Power Cord, 250VAC 10A CEI 23-16/VII Plug, Italy	
CAB-9K10A-SW	Power Cord, 250VAC 10A MP232 Plug, Switzerland	
CAB-9K10A-UK	Power Cord, 250VAC 10A BS1363 Plug (13 A fuse), UK	
CAB-9K12A-NA <sup>1</sup>	Power Cord, 125VAC 13A NEMA 5-15 Plug, North America	
CAB-250V-10A-BR	Power Cord - 250V, 10A - Brazil	
CAB-C13-C14-2M-JP	Power Cord C13-C14, 2M/6.5ft Japan PSE mark	Image not available
CAB-9K10A-KOR <sup>1</sup>	Power Cord, 125VAC 13A KSC8305 Plug, Korea	Image not available
CAB-ACTW	AC Power Cord (Taiwan), C13, EL 302, 2.3M	Image not available
CAB-JPN-3PIN	Japan, 90-125VAC 12A NEMA 5-15 Plug, 2.4m	Image not available
CAB-48DC-40A-INT	C-Series -48VDC PSU PWR Cord, 3.5M, 3 Wire, 8AWG, 40A (INT)	Image not available
CAB-48DC-40A-AS	C-Series -48VDC PSU PWR Cord, 3.5M, 3Wire, 8AWG, 40A (AS/NZ)	Image not available

Notes:

1. This power cord is rated to 125V and only supported for PSU rated at 1050W or less

Table 20 Available Power Cords (for servers with 2300 W PSUs)

Product ID (PID)	PID Description	Images
CAB-C19-CBN	Cabinet Jumper Power Cord, 250 VAC 16A, C20-C19 Connectors	Not applicable
CAB-S132-C19-ISRL	S132 to IEC-C19 14ft Israeli	Image not available
CAB-IR2073-C19-AR	IRSM 2073 to IEC-C19 14ft Argen	Image not available
CAB-BS1363-C19-UK	BS-1363 to IEC-C19 14ft UK	Image not available
CAB-SABS-C19-IND	SABS 164-1 to IEC-C19 India	Image not available
CAB-C2316-C19-IT	CEI 23-16 to IEC-C19 14ft Italy	Image not available
CAB-L520P-C19-US	NEMA L5-20 to IEC-C19 6ft US	Image not available
CAB-US515P-C19-US	NEMA 5-15 to IEC-C19 13ft US	Image not available
CAB-US520-C19-US	NEMA 5-20 to IEC-C19 14ft US	Image not available
CAB-US620P-C19-US	NEMA 6-20 to IEC-C19 13ft US	Image not available

## STEP 13 ORDER TOOL-LESS RAIL KIT AND OPTIONAL REVERSIBLE CABLE MANAGEMENT ARM

### Select a Tool-less Rail Kit

---

Select a tool-less rail kit (or no rail kit) from [Table 21](#).

Table 21 Tool-less Rail Kit Options

Product ID (PID)	PID Description
HCI-RAIL-M6	Ball Bearing Rail Kit for C220 & C240 M6 rack servers
HCI-RAIL-NONE	No rail kit option



**NOTE:** Cisco recommends a minimum quantity of 1 Rail Kit.

---

### Select an Optional Reversible Cable Management Arm

---

The reversible cable management arm mounts on either the right or left slide rails at the rear of the server and is used for cable management. Use [Table 22](#) to order a cable management arm.

Table 22 Cable Management Arm

Product ID (PID)	PID Description
HCI-CMA-C240M6	Reversible CMA for C240 M6 ball bearing rail kit

For more information about the tool-less rail kit and cable management arm, see the [Cisco server Installation and Service Guide](#).



**NOTE:** If you plan to rackmount your HCIAF240C M6 All-Flash Server, you must order a tool-less rail kit. The same rail kits and CMAs are used for M5 and M6 servers.

---

## STEP 14 ORDER SECURITY DEVICES (OPTIONAL)

A Trusted Platform Module (TPM) is a computer chip (microcontroller) that can securely store artifacts used to authenticate the platform (server). These artifacts can include passwords, certificates, or encryption keys. A TPM can also be used to store platform measurements that help ensure that the platform remains trustworthy. Authentication (ensuring that the platform can prove that it is what it claims to be) and attestation (a process helping to prove that a platform is trustworthy and has not been breached) are necessary steps to ensure safer computing in all environments.

A chassis intrusion switch gives a notification of any unauthorized mechanical access into the server.

The security device ordering information is listed in [Table 23](#).

**Table 23 Security Devices**

Product ID (PID)	PID Description
HCI-TPM-002C-M6	TPM 2.0, TCG, FIPS140-2, CC EAL4+ Certified, for M6 servers
HCI-INT-SW02-M6	C220 and C240 M6 Chassis Intrusion Switch
HCI-TPM-OPT-OUT-M6	OPT OUT, TPM 2.0, TCG, FIPS140-2, CC EAL4+ Certified <sup>1</sup>

**Notes:**

1. Please note that Microsoft certification requires a TPM 2.0 for bare-metal or guest VM deployments. Opt-out of the TPM 2.0 voids the Microsoft certification



**NOTE:**

- The TPM module used in this system conforms to TPM 2.0, as defined by the Trusted Computing Group (TCG). It is also SPI-based.
- TPM installation is supported after-factory. However, a TPM installs with a one-way screw and cannot be replaced, upgraded, or moved to another server. If a server with a TPM is returned, the replacement server must be ordered with a new TPM.

## STEP 15 SELECT HYPERVISOR

Cisco Hypervisor options are available as follows.

Table 24 Hypervisor

Product ID (PID)	PID Description
HCI-AOSAHV-SWK9M6	HCI AOS AHV SW



**NOTE:**

- This solution supports AHV hypervisor option. The Nutanix Foundation VM will perform bare-metal imaging for either hypervisor at time of install for FI management mode (HCI-FI-MANAGED-M6).
- For IS Management mode (HCI-IS-MANAGED-M6) bare metal image can be performed thorough Prism Central.





## STEP 16 SELECT NUTANIX SOFTWARE AND NUTANIX PROFESSIONAL SERVICES

- *Top Level Nutanix Software And Professional Services PIDs, page 41*
  - *Table 25, Top Level Nutanix Software And Professional Services PIDs*
- *Nutanix Software And Professional Services PID Decoder, page 43*
  - *Table 26.0, Nutanix Software PID Decoder (WW-XX-YY-ZZ)*
  - *Table 26.1, Nutanix Professional Services PID Decoder (WW-XX-YY-ZZ)*
- *Nutanix Software PIDs and Description, page 44*
  - *Table 29.0, Nutanix Cloud Infrastructure (NCI)*
  - *Table 29.1, Nutanix Cloud Infrastructure Data (NCI-D)*
  - *Table 29.2, Nutanix Cloud Infrastructure Edge (NCI-Edge)*
  - *Table 29.3, Nutanix Cloud Manager (NCM)*
  - *Table 29.4, Nutanix Cloud Platform (NCP)*
  - *Table 29.5, Nutanix Unified Storage™ (NUS)*
  - *Table 29.6, Nutanix Data Lens (NDL)*
  - *Table 29.7, End User Computing (EUC)*
- *Professional Services PIDs and Description, page 65*
  - *Table 30.0, NCI Design Workshop*
  - *Table 30.1, NCI Cluster Deployment or Expansion*
  - *Table 30.2, Virtual Machine Migration Workshop*
  - *Table 30.3, Virtual Machine Migration*
  - *Table 30.4, NCM Self-Service Design Workshop*
  - *Table 30.5, NCM Intelligent Operations Design Workshop*
  - *Table 30.6, NCM Intelligent Operations Deployment*
  - *Table 30.7, FastTrack for NCM Self-Service*
  - *Table 30.8, FastTrack for NCM Cost Governance*
  - *Table 30.9, Nutanix Flexible Credits*
- *Nutanix Support:, page 76*
- *Software With Professional Services PID Mapping, page 77*
  - *Table 32.0, Nutanix Software NCI, NCI-D, NCI-Edge, EUC, NCP (NCI-PRO), NCP (NCI-ULT) 1 YEAR SUBSCRIPTION with professional services PID Mapping*
  - *Table 32.1, Nutanix Software NCI, NCI-D, NCI-Edge, EUC, NCP (NCI-PRO), NCP (NCI-ULT) 3 YEAR SUBSCRIPTION with professional services PID Mapping*
  - *Table 33.0, Nutanix Software NCM STR 1 YEAR SUBSCRIPTION with professional services PID Mapping*
  - *Table 33.1, Nutanix Software NCM STR 3 YEAR AND ABOVE SUBSCRIPTION with Professional Services PID Mapping*
  - *Table 34, Nutanix Software NCM PRO, NCM ULT, NCP (NCM-PRO), NCP (NCM-ULT) 1 YEAR AND 3 YEAR & ABOVE SUBSCRIPTION with Professional services*

## Top Level Nutanix Software And Professional Services PIDs

Table 25 Top Level Nutanix Software And Professional Services PIDs

ATO Product ID (PID)	Description
NTX-SW	<p>Nutanix Software 3Y and above</p> <hr/>  <b>NOTE:</b> Please refer to the complete list of <a href="#">Nutanix Software PIDs and Description, page 44</a>
NTX-SW-1Y	<p>Nutanix Software 1Y</p> <hr/>  <b>NOTE:</b> Please refer to the complete list of <a href="#">Nutanix Software PIDs and Description, page 44</a>
NTX-SW-PS	<p>Nutanix Professional Service</p> <hr/>  <b>NOTE:</b> Please refer to the complete list of <a href="#">Professional Services PIDs and Description, page 65</a>

**NOTE:****(1) 1 Year Subscription term:**

- All Nutanix software package subscription requires **mandatory** attach of Nutanix Professional Services.

**(2) 3 Year Subscription term:**

- For Nutanix Cloud Infrastructure (NCI) software, it is **recommended** to attach Nutanix Professional Services during ordering.
- For Nutanix Cloud Manager (NCM) software, only Professional (PRO) subscription and Ultimate (ULT) subscription requires **mandatory** Nutanix Professional Services.

**(3) Any future expansion opportunity does not require **mandatory** Nutanix Professional Services attach.**

**(4) Cisco and Nutanix products are each subject to their own terms and conditions, including support timelines and milestones. This includes the Nutanix Cloud Platform software and qualified Cisco UCS hardware platforms sold together as part of the Cisco Compute Hyperconverged with Nutanix solution. Carefully review [Nutanix's EoL portal](#) for support timelines by hardware platform. Cisco's UCS hardware support milestones may not align with Nutanix's support milestones. Therefore, it is important to plan your hardware and software refresh cycles based on the earlier of the two dates (hardware support from Cisco and software support from Nutanix). It is your responsibility to check the Nutanix software term length desired against the support time frames for the quoted UCS hardware platform.**

Nutanix licenses are transferable to newer generation Cisco UCS platforms subject to Nutanix's end user license agreement. Refer to [Nutanix's Support FAQs](#) for details and definitions of Nutanix's End of Life and End of Support Life milestones. Refer to [Cisco's EoL policy](#) for details and definitions of Cisco's End of Life and Last Date of Support milestones.

---

## Nutanix Software And Professional Services PID Decoder

Table 26.0 Nutanix Software PID Decoder (WW-XX-YY-ZZ)

Identifier#1 (WW)	Identifier#2 (XX)	Identifier#3 (YY)	Identifier#4 (ZZ)
Nutanix Product Family:  NT	Nutanix Software Type/Category:  <b>NCI:</b> Nutanix Cloud Infrastructure <b>NCI-D:</b> Nutanix Cloud Infrastructure Data <b>NCI-E:</b> Nutanix Cloud Infrastructure Edge <b>NCM:</b> Nutanix Cloud Manager <b>NCP:</b> Nutanix Cloud Platform <b>NUS:</b> Nutanix Unified Storage™ <b>NDL:</b> Nutanix Data Lens <b>EUC:</b> End User Computing	License Tiers:  <b>STR:</b> Starter <b>PRO:</b> Professional <b>ULT:</b> Ultimate	Support Tier:  <b>PR:</b> Production <b>MC:</b> Mission Critical <b>FP:</b> US Federal Production <b>FM:</b> US Federal Mission Critical
<b>NOTE:</b> Note for example "NT-NCI-STR-PR" PID can be decoded as, NT=Nutanix, NCI=Nutanix Cloud Infrastructure, STR=Starter, PR=Production			

Table 26.1 Nutanix Professional Services PID Decoder (WW-XX-YY-ZZ)

Identifier#1 (WW)	Identifier#2 (XX)	Identifier#3 (YY)	Identifier#4 (ZZ)
Nutanix Product Family:  NT	Nutanix Professional Services Offering:  <b>Design</b> W-DS: NCI Design Workshop W-SSD: NCM Self-Service Design Workshop W-OD: NCM Intelligent Operations Design Workshop <b>Deploy</b> S-DP: NCI Cluster Deployment or Expansion S-OP: NCM Intelligent Operations Deployment F-SS: FastTrack for NCM Self-Service F-CG: FastTrack for NCM Cost Governance <b>Migrate</b> W-MG: Virtual Machine Migration Workshop S-MG-VM: Virtual Machine Migration <b>Custom</b> FLEX-CST-CR: Flexible Credits	Nutanix Product Tier:  <b>STR:</b> Starter <b>PRO:</b> Professional <b>ULT:</b> Ultimate	Nutanix Professional Services Option:  <b>Design</b> ED: Enhanced Documentation SD: Standard Documentation <b>Deploy</b> AV-PB: Pro AHV Nodes Base AV-PV: Pro AHV Nodes Variable EX-PB: Pro ESX Nodes Base EX-PV: Pro ESX Nodes Variable AV-SB: Starter AHV Nodes Base AV-SV: Starter AHV Nodes Variable EX-SB: Starter ESX Nodes Base EX-SV: Starter ESX Nodes Variable AVB: Starter AHV Nodes Base AVV: Starter AHV Nodes Variable EXB: Starter ESX Nodes Base EXV: Starter ESX Nodes Variable AV-UB: Ultimate AHV Nodes Base AV-UV: Ultimate AHV Nodes Variable EX-UB: Ultimate ESX Nodes Base EX-UV: Ultimate ESX Nodes Variable
<b>NOTE:</b> Note for example "NT-W-DS-STR-SD" PID can be decoded as, NT=Nutanix, W-DS= Design Workshop, STR=Starter, SD= Standard Documentation			

## Nutanix Software PIDs and Description

Table 27 Software Options and Metric

Software Option	Software Description	Metric
Nutanix Cloud Infrastructure (NCI)	NCI is a complete software stack to unify your hybrid cloud infrastructure including compute, storage and network, hypervisors, and containers, in public or enterprise clouds	Per Core
Nutanix Cloud Infrastructure Data (NCI-D)	Delivers rich data and storage services but does not include Nutanix compute and networking capabilities. No support for AHV	Per Core
Nutanix Cloud Infrastructure Edge (NCI-Edge)	Nutanix Cloud Infrastructure - Edge (NCI-Edge) provides a distributed infrastructure platform for small edge deployments. NCI-Edge provides the same capabilities as NCI, combining compute, storage, and networking resources from a cluster of servers into a single logical pool with integrated resiliency, security, performance, and simplified administration.	Per VM
Nutanix Cloud Manager (NCM)	NCM offers intelligent operations, self service and orchestration, visibility and governance of spend, security and teams	Per Core
Nutanix Cloud Platform (NCP)	Bundle for NCI and NCM	Per Core
Nutanix Unified Storage™ (NUS)	Nutanix Unified Storage™ (NUS) is a software-defined data services platform that consolidates the management and protection of siloed block, file, and object storage into a single, unified platform.	Per TIB
Nutanix Data Lens (NDL)	Nutanix Data Lens is a SaaS-based cyberstorage solution offering ransomware resilience and global data visibility for unstructured data on Nutanix Unified Storage (NUS).	Per TIB
End User Computing (EUC)	on-prem VDI and Desktop as a Service (DaaS) use cases	Per User

Table 28 Nutanix Software License Tiers

NCI Starter	NCI Professional	NCI Ultimate
<p>Core set of software functionality</p> <p><b>Ideal for:</b> Small-scale deployments with a limited set of workloads (on-prem only)</p>	<p>Rich data services, resilience and management features</p> <p><b>Ideal for:</b> Running multiple applications or large-scale single workload deployments (on-prem or in public clouds)</p>	<p>Full suite of Nutanix software capabilities to tackle complex infrastructure challenges</p> <p><b>Ideal for:</b> Multi-site deployments and advanced security requirements (on-prem or in public clouds)</p>



**NOTE:**

- Prism Central will be required for all licensing actions.
- Licenses are portable across Cisco hardware platforms in HCL.

**(1) Nutanix Cloud Infrastructure (NCI):**

Nutanix Cloud Infrastructure (NCI) converges the entire datacenter stack, including compute, storage, storage networking, and virtualization and is at the core of creating a hyperconverged infrastructure environment. Complex and expensive legacy infrastructure is replaced by NCI, running on industry-standard servers loaded with the latest hardware technologies. This allows enterprises to deploy what you need for the short term, and scale on-demand as infrastructure needs increase over time. Each server, often referred to as a node in the context of HCI, is an x86 platform with direct-attached storage drives. NCI software runs on each node, distributing all operating functions across the cluster for superior performance and resilience, and enabling seamless scalability.

**NOTE:**

- For more information about Nutanix Cloud Infrastructure (NCI), please visit <https://www.nutanix.com/products/nutanix-cloud-infrastructure>
- For more information about Nutanix Cloud Platform software options, please visit <https://www.nutanix.com/products/cloud-platform/software-options>
- Please note that the Federal Support program is reserved for US Federal accounts. US Federal accounts must select Federal Support Tier for the order to be fulfilled. If a non-Federal account selects a Federal Support program, Nutanix may not fulfill the order. Additionally, Nutanix's Mixed Support Level Guidelines(<https://www.nutanix.com/support-services/product-support/support-policies-and-faqs?show=accordion-4>) requires all software assets within a cluster to have the same support level, else software support will default to the lower option.
- Sellers in the Federal space need to ensure they have the Federal Support SKU's on the quote and order. All orders without the Federal Support SKU's will be rejected by Nutanix. Refer this Knowledge base article for more info: <https://compute.kb.cisco.com/article/nutanix-support-for-federal-customers.html>

**Table 29.0 Nutanix Cloud Infrastructure (NCI)**

Product ID (PID)	PID Description
<b>STR - STARTER</b>	
NT-NCI-STR-PR	Subscription, Nutanix Cloud Infrastructure (NCI) Starter Software License & Production Software Support Service for 1 CPU Core
NT-NCI-STR-MC	Subscription, Nutanix Cloud Infrastructure (NCI) Starter Software License & Mission Critical Software Support Service for 1 CPU Core
NT-NCI-STR-FP	Subscription, Nutanix Cloud Infrastructure (NCI) Starter Software License & Federal Production Software Support Service for 1 CPU Core
NT-NCI-STR-FM	Subscription, Nutanix Cloud Infrastructure (NCI) Starter Software License & Federal Mission Critical Software Support Service for 1 CPU Core
<b>PRO - PROFESSIONAL</b>	
NT-NCI-PRO-PR	Subscription, Nutanix Cloud Infrastructure (NCI) Pro Software License & Production Software Support Service for 1 CPU Core
NT-NCI-PRO-MC	Subscription, Nutanix Cloud Infrastructure (NCI) Pro Software License & Mission Critical Software Support Service for 1 CPU Core

**Table 29.0 Nutanix Cloud Infrastructure (NCI)**

NT-NCI-PRO-FP	Subscription, Nutanix Cloud Infrastructure (NCI) Pro Software License & Federal Production Software Support Service for 1 CPU Core
NT-NCI-PRO-FM	Subscription, Nutanix Cloud Infrastructure (NCI) Pro Software License & Federal Mission Critical Software Support Service for 1 CPU Core
<b>ULT - ULTIMATE</b>	
NT-NCI-ULT-PR	Subscription, Nutanix Cloud Infrastructure (NCI) Ultimate Software License & Production Software Support Service for 1 CPU Core
NT-NCI-ULT-MC	Subscription, Nutanix Cloud Infrastructure (NCI) Ultimate Software License & Mission Critical Software Support Service for 1 CPU Core
NT-NCI-ULT-FP	Subscription, Nutanix Cloud Infrastructure (NCI) Ultimate Software License & Federal Production Software Support Service for 1 CPU Core
NT-NCI-ULT-FM	Subscription, Nutanix Cloud Infrastructure (NCI) Ultimate Software License & Federal Mission Critical Software Support Service for 1 CPU Core
<b>ADVANCED REPLICATION</b>	
NT-A-NCI-ADR-PR	Subscription, Nutanix Cloud Infrastructure (NCI) Advanced Replication add-on Software License & Production Software Support Service for 1 CPU Core
NT-A-NCI-ADR-MC	Subscription, Nutanix Cloud Infrastructure (NCI) Advanced Replication add-on Software License & Mission Critical Software Support Service for 1 CPU Core
NT-A-NCI-ADR-FP	Subscription, Nutanix Cloud Infrastructure (NCI) Advanced Replication add-on Software License & Federal Production Software Support Service for 1 CPU Core
NT-A-NCI-ADR-FM	Subscription, Nutanix Cloud Infrastructure (NCI) Advanced Replication add-on Software License & Federal Mission Critical Software Support Service for 1 CPU Core
<b>KUBERNETES</b>	
NT-A-NCI-NKS-PR	Subscription, Nutanix Cloud Infrastructure (NCI) Kubernetes Engine add-on Software License & Production Software Support Service for 1 CPU Core
NT-A-NCI-NKS-MC	Subscription, Nutanix Cloud Infrastructure (NCI) Kubernetes Engine add-on Software License & Mission Critical Software Support Service for 1 CPU Core
NT-A-NCI-NKS-FP	Subscription, Nutanix Cloud Infrastructure (NCI) Kubernetes Engine add-on Software License & Federal Production Software Support Service for 1 CPU Core
NT-A-NCI-NKS-FM	Subscription, Nutanix Cloud Infrastructure (NCI) Kubernetes Engine add-on Software License & Federal Mission Critical Software Support Service for 1 CPU Core
<b>SECURITY</b>	
NT-A-NCI-SEC-PR	Subscription, Nutanix Cloud Infrastructure (NCI) Security add-on Software License & Production Software Support Service for 1 CPU Core
NT-A-NCI-SEC-MC	Subscription, Nutanix Cloud Infrastructure (NCI) Security add-on Software License & Mission Critical Software Support Service for 1 CPU Core

Table 29.0 Nutanix Cloud Infrastructure (NCI)

NT-A-NCI-SEC-FP	Subscription, Nutanix Cloud Infrastructure (NCI) Security add-on Software License & Federal Production Software Support Service for 1 CPU Core
NT-A-NCI-SEC-FM	Subscription, Nutanix Cloud Infrastructure (NCI) Security add-on Software License & Federal Mission Critical Software Support Service for 1 CPU Core



**NOTE:** The quantity of NCI-D license must match with total number for cores in hardware platforms.

*Table 32.0, Nutanix Software NCI, NCI-D, NCI-Edge, EUC, NCP (NCI-PRO), NCP (NCI-ULT) 1 YEAR SUBSCRIPTION with professional services PID Mapping*

*Table 32.1, Nutanix Software NCI, NCI-D, NCI-Edge, EUC, NCP (NCI-PRO), NCP (NCI-ULT) 3 YEAR SUBSCRIPTION with professional services PID Mapping*



(2) Nutanix Cloud Infrastructure Data (NCI-D):

Nutanix supports freedom of choice of hypervisor and container platform, by offering a version called NCI Data that delivers rich data and storage services but does not include Nutanix compute and networking capabilities. Support for Hypervisor specific features, such as GPU support on ESXi, is not impacted by NCI Data licensing tiers.



**NOTE:**

- For more information about Nutanix Cloud Infrastructure (NCI), please visit <https://www.nutanix.com/products/nutanix-cloud-infrastructure>
- For more information about Nutanix Cloud Platform software options, please visit <https://www.nutanix.com/products/cloud-platform/software-options> Please note, the grey rows in the software options table under NCI are not included in NCI Data.
- Please note that the Federal Support program is reserved for US Federal accounts. US Federal accounts must select Federal Support Tier for the order to be fulfilled. If a non-Federal account selects a Federal Support program, Nutanix may not fulfill the order. Additionally, Nutanix's Mixed Support Level Guidelines(<https://www.nutanix.com/support-services/product-support/support-policies-and-faqs?show=accordion-4>) requires all software assets within a cluster to have the same support level, else software support will default to the lower option.
- Sellers in the Federal space need to ensure they have the Federal Support SKU's on the quote and order. All orders without the Federal Support SKU's will be rejected by Nutanix.Refer this Knowledge base article for more info: <https://compute.kb.cisco.com/article/nutanix-support-for-federal-customers.html>

Table 29.1 Nutanix Cloud Infrastructure Data (NCI-D)

Product ID (PID)	PID Description
<b>STR - STARTER</b>	
NT-NCI-D-STR-PR	Subscription, Nutanix Cloud Infrastructure Data (NCI-D) Starter Software License & Production Software Support Service for 1 CPU Core
NT-NCI-D-STR-MC	Subscription, Nutanix Cloud Infrastructure Data (NCI-D) Starter Software License & Mission Critical Software Support Service for 1 CPU Core
NT-NCI-D-STR-FP	Subscription, Nutanix Cloud Infrastructure Data (NCI-D) Starter Software License & Federal Production Software Support Service for 1 CPU Core
NT-NCI-D-STR-FM	Subscription, Nutanix Cloud Infrastructure Data (NCI-D) Starter Software License & Federal Mission Critical Software Support Service for 1 CPU Core
<b>PRO - PROFESSIONAL</b>	
NT-NCI-D-PRO-PR	Subscription, Nutanix Cloud Infrastructure Data (NCI-D) Pro Software License & Production Software Support Service for 1 CPU Core
NT-NCI-D-PRO-MC	Subscription, Nutanix Cloud Infrastructure Data (NCI-D) Pro Software License & Mission Critical Software Support Service for 1 CPU Core
NT-NCI-D-PRO-FP	Subscription, Nutanix Cloud Infrastructure Data (NCI-D) Pro Software License & Federal Production Software Support Service for 1 CPU Core

**Table 29.1 Nutanix Cloud Infrastructure Data (NCI-D)**

NT-NCI-D-PRO-FM	Subscription, Nutanix Cloud Infrastructure Data (NCI-D) Pro Software License & Federal Mission Critical Software Support Service for 1 CPU Core
<b>ULT - ULTIMATE</b>	
NT-NCI-D-ULT-PR	Subscription, Nutanix Cloud Infrastructure Data (NCI-D) Ultimate Software License & Production Software Support Service for 1 CPU Core
NT-NCI-D-ULT-MC	Subscription, Nutanix Cloud Infrastructure Data (NCI-D) Ultimate Software License & Mission Critical Software Support Service for 1 CPU Core
NT-NCI-D-ULT-FP	Subscription, Nutanix Cloud Infrastructure Data (NCI-D) Ultimate Software License & Federal Production Software Support Service for 1 CPU Core
NT-NCI-D-ULT-FM	Subscription, Nutanix Cloud Infrastructure Data (NCI-D) Ultimate Software License & Federal Mission Critical Software Support Service for 1 CPU Core
<b>ADVANCED REPLICATION</b>	
NT-A-NCI-D-ADR-PR	Subscription, Nutanix Cloud Infrastructure Data (NCI-D) Advanced Replication add-on Software License & Production Software Support Service for 1 CPU Core
NT-A-NCI-D-ADR-MC	Subscription, Nutanix Cloud Infrastructure Data (NCI-D) Advanced Replication add-on Software License & Mission Critical Software Support Service for 1 CPU Core
NT-A-NCI-D-ADR-FP	Subscription, Nutanix Cloud Infrastructure Data (NCI-D) Advanced Replication add-on Software License & Federal Production Software Support Service for 1 CPU Core
NT-A-NCI-D-ADR-FM	Subscription, Nutanix Cloud Infrastructure Data (NCI-D) Advanced Replication add-on Software License & Federal Mission Critical Software Support Service for 1 CPU Core
<b>SECURITY</b>	
NT-A-NCI-D-SEC-PR	Subscription, Nutanix Cloud Infrastructure Data (NCI-D) Security add-on Software License & Production Software Support Service for 1 CPU Core
NT-A-NCI-D-SEC-MC	Subscription, Nutanix Cloud Infrastructure Data (NCI-D) Security add-on Software License & Mission Critical Software Support Service for 1 CPU Core
NT-A-NCI-D-SEC-FP	Subscription, Nutanix Cloud Infrastructure Data (NCI-D) Security add-on Software License & Federal Production Software Support Service for 1 CPU Core
NT-A-NCI-D-SEC-FM	Subscription, Nutanix Cloud Infrastructure Data (NCI-D) Security add-on Software License & Federal Mission Critical Software Support Service for 1 CPU Core



**NOTE:** The quantity of NCI-D license must match with total number for cores in hardware platforms.

*Table 32.0, Nutanix Software NCI, NCI-D, NCI-Edge, EUC, NCP (NCI-PRO), NCP (NCI-ULT) 1 YEAR SUBSCRIPTION with professional services PID Mapping*

*Table 32.1, Nutanix Software NCI, NCI-D, NCI-Edge, EUC, NCP (NCI-PRO), NCP (NCI-ULT) 3 YEAR SUBSCRIPTION with professional services PID Mapping*

**(3) Nutanix Cloud Infrastructure Edge (NCI-Edge):**

Nutanix Cloud Infrastructure - Edge (NCI-Edge) provides a distributed infrastructure platform for small edge deployments. NCI-Edge provides the same capabilities as NCI, combining compute, storage, and networking resources from a cluster of servers into a single logical pool with integrated resiliency, security, performance, and simplified administration. With NCI-Edge, organizations can efficiently extend the Nutanix platform to remote office/branch office (ROBO) and other edge use cases.

- 1 TiB of NUS Pro per NCI-Edge cluster is included at no cost with NCI-Edge.
- NCI-Edge licenses must run on a dedicated licensed cluster with no core-based licensing. Mixing of NCI-Edge licenses with other types of NCI licensing within a cluster is not supported.
- NCI-Edge can be used with any cluster deployment type as long as the conditions mentioned are followed.
- Maximum nodes for the Edge cluster is 5.



**NOTE:**

- NCI-Edge is limited to a maximum of 25 VMs in a cluster, with each VM being limited to a maximum of 96GB of memory.
- For more information about Nutanix Cloud Infrastructure (NCI), please visit <https://www.nutanix.com/products/nutanix-cloud-infrastructure>
- For more information about Nutanix NCI Edge software options, please visit <https://www.nutanix.com/products/cloud-platform/software-options>
- Please note that the Federal Support program is reserved for US Federal accounts. US Federal accounts must select Federal Support Tier for the order to be fulfilled. If a non-Federal account selects a Federal Support program, Nutanix may not fulfill the order. Additionally, Nutanix's Mixed Support Level Guidelines(<https://www.nutanix.com/support-services/product-support/support-policies-and-faqs?show=accordion-4>) requires all software assets within a cluster to have the same support level, else software support will default to the lower option.
- Sellers in the Federal space need to ensure they have the Federal Support SKU's on the quote and order. All orders without the Federal Support SKU's will be rejected by Nutanix. Refer this Knowledge base article for more info: <https://computekb.cisco.com/article/nutanix-support-for-federal-customers.html>

**Table 29.2 Nutanix Cloud Infrastructure Edge (NCI-Edge)**

Product ID (PID)	PID Description
<b>STR - STARTER</b>	
NT-NCI-E-STR-PR	Subscription, Nutanix Cloud Infrastructure (NCI) Starter Software License for Edge sites & Production Software Support Service for 1 VM
NT-NCI-E-STR-MC	Subscription, Nutanix Cloud Infrastructure (NCI) Starter Software License for Edge sites & Mission Critical Software Support Service for 1 VM
NT-NCI-E-STR-FP	Subscription, Nutanix Cloud Infrastructure (NCI) Starter Software License for Edge sites & Federal Production Software Support Service for 1 VM
NT-NCI-E-STR-FM	Subscription, Nutanix Cloud Infrastructure (NCI) Starter Software License for Edge sites & Federal Mission Critical Software Support Service for 1 VM

Table 29.2 Nutanix Cloud Infrastructure Edge (NCI-Edge)

PRO - PROFESSIONAL	
NT-NCI-E-PRO-PR	Subscription, Nutanix Cloud Infrastructure (NCI) Pro Software License for Edge sites & Production Software Support Service for 1 VM
NT-NCI-E-PRO-MC	Subscription, Nutanix Cloud Infrastructure (NCI) Pro Software License for Edge sites & Mission Critical Software Support Service for 1 VM
NT-NCI-E-PRO-FP	Subscription, Nutanix Cloud Infrastructure (NCI) Pro Software License for Edge sites & Federal Production Software Support Service for 1 VM
NT-NCI-E-PRO-FM	Subscription, Nutanix Cloud Infrastructure (NCI) Pro Software License for Edge sites & Federal Mission Critical Software Support Service for 1 VM
ULT - ULTIMATE	
NT-NCI-E-ULT-PR	Subscription, Nutanix Cloud Infrastructure (NCI) Ultimate Software License for Edge sites & Production Software Support Service for 1 VM
NT-NCI-E-ULT-MC	Subscription, Nutanix Cloud Infrastructure (NCI) Ultimate Software License for Edge sites & Mission Critical Software Support Service for 1 VM
NT-NCI-E-ULT-FP	Subscription, Nutanix Cloud Infrastructure (NCI) Ultimate Software License for Edge sites & Federal Production Software Support Service for 1 VM
NT-NCI-E-ULT-FM	Subscription, Nutanix Cloud Infrastructure (NCI) Ultimate Software License for Edge sites & Federal Mission Critical Software Support Service for 1 VM

**NOTE:**

- NCI-Edge is limited to a maximum of 25 VMs in a cluster, with each VM being limited to a maximum of 96GB of memory.
- Maximum nodes for the Edge cluster is 5
- The quantity of NCI-Edge license must match with Total number for VMs running in the cluster.
- For the purpose of calculation, internal VMs (or Nutanix infrastructure VMs) such as Controller VM or Prism Central VM are not counted.

*Table 32.0, Nutanix Software NCI, NCI-D, NCI-Edge, EUC, NCP (NCI-PRO), NCP (NCI-ULT) 1 YEAR SUBSCRIPTION with professional services PID Mapping*

*Table 32.1, Nutanix Software NCI, NCI-D, NCI-Edge, EUC, NCP (NCI-PRO), NCP (NCI-ULT) 3 YEAR SUBSCRIPTION with professional services PID Mapping*

**(4) Nutanix Cloud Manager (NCM):**

Nutanix Cloud Manager (NCM) is a hybrid multi-cloud management platform for building a cloud operating model. NCM provides Intelligent Operations, Self-Service, Cost Governance, and Security natively with the Nutanix Platform or through a SaaS subscription.

- Self-service VMs and Apps are defined via simple blueprints, easily created, and managed via GUI/CLI.
- Management of IT lifecycle includes visibility, optimization, and financial control over multi-cloud deployments.
- Detect, monitor, and remediate security vulnerabilities and compliance near real-time across multiple cloud environment



**NOTE:**

- For more information Nutanix Cloud Manager (NCM), please visit <https://www.nutanix.com/products/cloud-manager>
- For more information about Nutanix Cloud Platform software options, please visit <https://www.nutanix.com/products/cloud-platform/software-options>
- Please note that the Federal Support program is reserved for US Federal accounts. US Federal accounts must select Federal Support Tier for the order to be fulfilled. If a non-Federal account selects a Federal Support program, Nutanix may not fulfill the order. Additionally, Nutanix's Mixed Support Level Guidelines(<https://www.nutanix.com/support-services/product-support/support-policies-and-faqs?show=accordion-4>) requires all software assets within a cluster to have the same support level, else software support will default to the lower option.
- Sellers in the Federal space need to ensure they have the Federal Support SKU's on the quote and order. All orders without the Federal Support SKU's will be rejected by Nutanix. Refer this Knowledge base article for more info: <https://compute.kb.cisco.com/article/nutanix-support-for-federal-customers.html>

**Table 29.3 Nutanix Cloud Manager (NCM)**

Product ID (PID)	PID Description
<b>STR - STARTER</b>	
NT-NCM-STR-PR	Subscription, Nutanix Cloud Manager (NCM) Starter Software License & Production Software Support Service for 1 CPU Core
NT-NCM-STR-MC	Subscription, Nutanix Cloud Manager (NCM) Starter Software License & Mission Critical Software Support Service for 1 CPU Core
NT-NCM-STR-FP	Subscription, Nutanix Cloud Manager (NCM) Starter Software License & Federal Production Software Support Service for 1 CPU Core
NT-NCM-STR-FM	Subscription, Nutanix Cloud Manager (NCM) Starter Software License & Federal Mission Critical Software Support Service for 1 CPU Core
<b>PRO - PROFESSIONAL</b>	
NT-NCM-PRO-PR	Subscription, Nutanix Cloud Manager (NCM) Pro Software License & Production Software Support Service for 1 CPU Core

Table 29.3 Nutanix Cloud Manager (NCM)

NT-NCM-PRO-MC	Subscription, Nutanix Cloud Manager (NCM) Pro Software License & Mission Critical Software Support Service for 1 CPU Core
NT-NCM-PRO-FP	Subscription, Nutanix Cloud Manager (NCM) Pro Software License & Federal Production Software Support Service for 1 CPU Core
NT-NCM-PRO-FM	Subscription, Nutanix Cloud Manager (NCM) Pro Software License & Federal Mission Critical Software Support Service for 1 CPU Core
<b>ULT - ULTIMATE</b>	
NT-NCM-ULT-PR	Subscription, Nutanix Cloud Manager (NCM) Ultimate Software License & Production Software Support Service for 1 CPU Core
NT-NCM-ULT-MC	Subscription, Nutanix Cloud Manager (NCM) Ultimate Software License & Mission Critical Software Support Service for 1 CPU Core
NT-NCM-ULT-FP	Subscription, Nutanix Cloud Manager (NCM) Ultimate Software License & Federal Production Software Support Service for 1 CPU Core
NT-NCM-ULT-FM	Subscription, Nutanix Cloud Manager (NCM) Ultimate Software License & Federal Mission Critical Software Support Service for 1 CPU Core
<b>COST GOVERNANCE</b>	
NT-NCM-CM-FP	Subscription, NCM Cost Governance as a Service for US Federal including Production Support for 1 VM
NT-NCM-CM-OV-FP	Overage, NCM Cost Governance as a Service for US Federal including Production Support for 1 VM
NT-NCM-CM-OV-PR	Overage, NCM Cost Governance as a Service including Production Support for 1 VM
NT-NCM-CM-PR	Subscription, NCM Cost Governance as a Service including Production Support for 1 VM
<b>SECURITY CENTRAL</b>	
NT-NCM-SC-FP	Subscription, NCM Security Central as a Service for US Federal including Production Support for 1 VM
NT-NCM-SC-OV-FP	Overage, NCM Security Central as a Service for US Federal including Production Support for 1 VM
NT-NCM-SC-OV-PR	Overage, NCM Security Central as a Service including Production Support for 1 VM
NT-NCM-SC-PR	Subscription, NCM Security Central as a Service including Production Support for 1 VM
<b>SELF SERVICE</b>	
NT-NCM-SS-OV-PR	Overage, NCM Self-Service & Orchestration as a Service including Production Support for 1 VM
NT-NCM-SS-PR	Subscription, NCM Self-Service & Orchestration as a Service including Production Support for 1 VM



**NOTE:** The quantity of NCM license must match with Total number for cores in hardware platforms.

---

*Table 33.0, Nutanix Software NCM STR 1 YEAR SUBSCRIPTION with professional services PID Mapping*

*Table 33.1, Nutanix Software NCM STR 3 YEAR AND ABOVE SUBSCRIPTION with Professional Services PID Mapping*

*Table 34, Nutanix Software NCM PRO, NCM ULT, NCP (NCM-PRO), NCP (NCM-ULT) 1 YEAR AND 3 YEAR & ABOVE SUBSCRIPTION with Professional services*

**(5) Nutanix Cloud Platform (NCP):**

Nutanix Cloud Infrastructure (NCI) and Nutanix Cloud Manager (NCM) can be purchased together in ‘better together’ Nutanix Cloud Platform (NCP) bundles:

Nutanix Cloud Platform (NCP)	Nutanix Cloud Infrastructure (NCI) included	Nutanix Cloud Manager (NCM) Edition included
NCP Starter	NCI Professional	NCM Professional
NCP Professional	NCI Ultimate	NCM Professional
NCP Ultimate	NCI Ultimate	NCM Ultimate

**NOTE:**

- For more information on Nutanix Cloud Platform (NCP) bundles, please visit <https://www.nutanix.com/products/cloud-platform/software-options>
- For more information about Nutanix Cloud Platform software options, please visit <https://www.nutanix.com/products/cloud-platform/software-options>
- Please note that the Federal Support program is reserved for US Federal accounts. US Federal accounts must select Federal Support Tier for the order to be fulfilled. If a non-Federal account selects a Federal Support program, Nutanix may not fulfill the order. Additionally, Nutanix’s Mixed Support Level Guidelines(<https://www.nutanix.com/support-services/product-support/support-policies-and-faqs?show=accordion-4>) requires all software assets within a cluster to have the same support level, else software support will default to the lower option.
- Sellers in the Federal space need to ensure they have the Federal Support SKU's on the quote and order. All orders without the Federal Support SKU's will be rejected by Nutanix. Refer this Knowledge base article for more info: <https://computekb.cisco.com/article/nutanix-support-for-federal-customers.html>

**Table 29.4 Nutanix Cloud Platform (NCP)**

Product ID (PID)	PID Description
<b>STR - STARTER</b>	
NT-NCP-STR-PR	Subscription, Nutanix Cloud Platform Starter Software License & Production Software Support Service for 1 CPU Core
NT-NCP-STR-MC	Subscription, Nutanix Cloud Platform Starter Software License & Mission Critical Software Support Service for 1 CPU Core
NT-NCP-STR-FP	Subscription, Nutanix Cloud Platform Starter Software License & Federal Production Software Support Service for 1 CPU Core
NT-NCP-STR-FM	Subscription, Nutanix Cloud Platform Starter Software License & Federal Mission Critical Software Support Service for 1 CPU Core
<b>PRO- PROFESSIONAL</b>	
NT-NCP-PRO-PR	Subscription, Nutanix Cloud Platform Pro Software License & Production Software Support Service for 1 CPU Core



**Table 29.4 Nutanix Cloud Platform (NCP)**

NT-NCP-PRO-MC	Subscription, Nutanix Cloud Platform Pro Software License & Mission Critical Software Support Service for 1 CPU Core
NT-NCP-PRO-FP	Subscription, Nutanix Cloud Platform Pro Software License & Federal Production Software Support Service for 1 CPU Core
NT-NCP-PRO-FM	Subscription, Nutanix Cloud Platform Pro Software License & Federal Mission Critical Software Support Service for 1 CPU Core
<b>ULT-ULTIMATE</b>	
NT-NCP-ULT-PR	Subscription, Nutanix Cloud Platform Ultimate Software License & Production Software Support Service for 1 CPU Core
NT-NCP-ULT-MC	Subscription, Nutanix Cloud Platform Ultimate Software License & Mission Critical Software Support Service for 1 CPU Core
NT-NCP-ULT-FP	Subscription, Nutanix Cloud Platform Ultimate Software License & Federal Production Software Support Service for 1 CPU Core
NT-NCP-ULT-FM	Subscription, Nutanix Cloud Platform Ultimate Software License & Federal Mission Critical Software Support Service for 1 CPU Core
<b>NCI PROFESSIONAL</b>	
NT-NCP-NCI-PRO-PR	Subscription, (included in NCP) Nutanix Cloud Infrastructure (NCI) Pro Software License & Production Software Support Service for 1 CPU Core
NT-NCP-NCI-PRO-MC	Subscription, (included in NCP) Nutanix Cloud Infrastructure (NCI) Pro Software License & Mission Critical Software Support Service for 1 CPU Core
NT-NCP-NCI-PRO-FP	Subscription, (included in NCP) Nutanix Cloud Infrastructure (NCI) Pro Software License & Federal Production Software Support Service for 1 CPU Core
NT-NCP-NCI-PRO-FM	Subscription, (included in NCP) Nutanix Cloud Infrastructure (NCI) Pro Software License & Federal Mission Critical Software Support Service for 1 CPU Core
<b>NCI ULTIMATE</b>	
NT-NCP-NCI-ULT-PR	Subscription, (included in NCP) Nutanix Cloud Infrastructure (NCI) Ultimate Software License & Production Software Support Service for 1 CPU Core
NT-NCP-NCI-ULT-MC	Subscription, (included in NCP) Nutanix Cloud Infrastructure (NCI) Ultimate Software License & Mission Critical Software Support Service for 1 CPU Core
NT-NCP-NCI-ULT-FP	Subscription, (included in NCP) Nutanix Cloud Infrastructure (NCI) Ultimate Software License & Federal Production Software Support Service for 1 CPU Core
NT-NCP-NCI-ULT-FM	Subscription, (included in NCP) Nutanix Cloud Infrastructure (NCI) Ultimate Software License & Federal Mission Critical Software Support Service for 1 CPU Core
<b>NCM PROFESSIONAL</b>	
NT-NCP-NCM-PRO-PR	Subscription, (included in NCP) Nutanix Cloud Manager (NCM) Pro Software License & Production Software Support Service for 1 CPU Core
NT-NCP-NCM-PRO-MC	Subscription, (included in NCP) Nutanix Cloud Manager (NCM) Pro Software License & Mission Critical Software Support Service for 1 CPU Core

**Table 29.4 Nutanix Cloud Platform (NCP)**

NT-NCP-NCM-PRO-FP	Subscription, (included in NCP) Nutanix Cloud Manager (NCM) Pro Software License & Federal Production Software Support Service for 1 CPU Core
NT-NCP-NCM-PRO-FM	Subscription, (included in NCP) Nutanix Cloud Manager (NCM) Pro Software License & Federal Mission Critical Software Support Service for 1 CPU Core
<b>NCM ULTIMATE</b>	
NT-NCP-NCM-ULT-PR	Subscription, (included in NCP) Nutanix Cloud Manager (NCM) Ultimate Software License & Production Software Support Service for 1 CPU Core
NT-NCP-NCM-ULT-MC	Subscription, (included in NCP) Nutanix Cloud Manager (NCM) Ultimate Software License & Mission Critical Software Support Service for 1 CPU Core
NT-NCP-NCM-ULT-FP	Subscription, (included in NCP) Nutanix Cloud Manager (NCM) Ultimate Software License & Federal Production Software Support Service for 1 CPU Core
NT-NCP-NCM-ULT-FM	Subscription, (included in NCP) Nutanix Cloud Manager (NCM) Ultimate Software License & Federal Mission Critical Software Support Service for 1 CPU Core

**NOTE:**

- The total number of cores for NCI and NCM should be same
- The support tiers for NCI and NCM should be same.

*Table 33.0, Nutanix Software NCM STR 1 YEAR SUBSCRIPTION with professional services PID Mapping*

*Table 33.1, Nutanix Software NCM STR 3 YEAR AND ABOVE SUBSCRIPTION with Professional Services PID Mapping*

*Table 34, Nutanix Software NCM PRO, NCM ULT, NCP (NCM-PRO), NCP (NCM-ULT) 1 YEAR AND 3 YEAR & ABOVE SUBSCRIPTION with Professional services*

**(6) Nutanix Unified Storage™ (NUS):**

Nutanix Unified Storage™ (NUS) is a software-defined data services platform that consolidates the management and protection of siloed block, file, and object storage into a single, unified platform. NUS harnesses the power of rich data services such as analytics, ransomware protection, lifecycle management, and data protection. These features enable organizations to seamlessly adapt to the ever-changing requirements of modern applications, allowing them to shift their management focus from data storage to data management. Leveraging the Nutanix Cloud Platform™ (NCP) software, NUS is specifically built to meet the needs of modern applications deployed across core, cloud, and edge infrastructure. With its capacity for seamless scaling, high performance, and integrated data security, NUS provides a comprehensive solution for organizations.

**Includes:**

- **Nutanix Files Storage:** simple and secure software-defined scale-out file storage solution to store, manage, and scale files data (NFS and SMB)
- **Nutanix Objects Storage:** distributed scale-out S3-compatible object storage for both archive and high-performance analytics
- **Nutanix Volumes Storage:** high-performance low-latency block storage
- **Nutanix Data Lens:** available as an add-on for data analytics, anomaly behavior detection and ransomware protection
- **Nutanix AOS:** scale-out storage technology that makes hyperconverged infrastructure (HCI) possible.
- **Nutanix AHV:** lightweight cloud hypervisor built into Nutanix platform and offers enterprise-grade storage capabilities and built-in Kubernetes support.
- **App VMs running on storage:** NUS dedicated clusters are entitled to 1 app/user VM per node in the cluster. NCI clusters don't have any limit on the number of app/user VMs on the cluster.

**NOTE:**

- For more information **Nutanix Unified Storage™ (NUS)**, please visit <https://www.nutanix.com/products/cloud-platform/software-options#nus>
  - For more information about Nutanix Cloud Platform software options, please visit <https://www.nutanix.com/products/cloud-platform/software-options>
  - Please note that the Federal Support program is reserved for US Federal accounts. US Federal accounts must select Federal Support Tier for the order to be fulfilled. If a non-Federal account selects a Federal Support program, Nutanix may not fulfill the order. Additionally, Nutanix's Mixed Support Level Guidelines(<https://www.nutanix.com/support-services/product-support/support-policies-and-faqs?show=accordion-4>) requires all software assets within a cluster to have the same support level, else software support will default to the lower option.
  - Sellers in the Federal space need to ensure they have the Federal Support SKU's on the quote and order. All orders without the Federal Support SKU's will be rejected by Nutanix. Refer this Knowledge base article for more info: <https://compute.kb.cisco.com/article/nutanix-support-for-federal-customers.html>
-

Table 29.5 Nutanix Unified Storage™ (NUS)

Product ID (PID)	PID Description
<b>PRO - PROFESSIONAL</b>	
NT-NUS-PRO-PR	Nutanix Unified Storage Professional Software License & Production Software Support for 1 TiB
NT-NUS-PRO-MC	Nutanix Unified Storage Professional Software License & Mission Critical Software Support for 1 TiB
NT-NUS-PRO-FP	Nutanix Unified Storage Professional Software License & Federal Production Software Support for 1 TiB
NT-NUS-PRO-FM	Nutanix Unified Storage Professional Software License & Federal Mission Critical Software Support for 1 TiB
<b>ADVANCED REPLICATION</b>	
NT-A-NUS-ADR-PR	Nutanix Unified Storage Advanced Replication add-on Software License & Production Software Support 1 TiB
NT-A-NUS-ADR-MC	Nutanix Unified Storage Advanced Replication add-on Software License & Mission Critical Software Support 1 TiB
NT-A-NUS-ADR-FP	Nutanix Unified Storage Advanced Replication add-on Software License & Federal Production Software Support 1 TiB
NT-A-NUS-ADR-FM	Nutanix Unified Storage Advanced Replication add-on Software License & Federal Mission Critical Support 1 TiB
<b>SECURITY</b>	
NT-A-NUS-SEC-PR	Nutanix Unified Storage Security add-on Software License & Production Software Support 1 TiB
NT-A-NUS-SEC-MC	Nutanix Unified Storage Security add-on Software License & Mission Critical Software Support 1 TiB
NT-A-NUS-SEC-FP	Nutanix Unified Storage Security add-on Software License & Federal Production Software Support 1 TiB
NT-A-NUS-SEC-FM	Nutanix Unified Storage Security add-on Software License & Federal Mission Critical Software Support 1 TiB

Table 29.5.a Nutanix Unified Storage Allowed Capacity

Nutanix Unified Storage	Nutanix Unified Storage Support Tier	Storage Capacity Allowed (TIB)
<p><b>Pro (Professional) License Tier (NT-NUS-PRO-*) Advanced Replication (NT-A-NUS-ADR-*) Security (NT-A-NUS-SEC-*)</b></p>	<p><b>Production Mission Critical Federal Production Federal Mission Critical</b></p>	1-50
		75
		100
		150
		200
		250
		300
		350
		400
		450
		500
		550
		600
		700
		800
		900
		1000
		1200
		1400
		1600
		1800
		2000
		2200
		2400
2600		
2800		
3000		
4000		
5000		
6000		
7000		
8000		
9000		
10000		

**(7) Nutanix Data Lens (NDL):**

Nutanix Data Lens is a SaaS-based cyberstorage solution offering ransomware resilience and global data visibility for unstructured data on Nutanix Unified Storage (NUS). This cloud-based data analytics service proactively assesses and mitigates data security risks by identifying anomalous activity, auditing user behavior, and adhering to compliance requirements. while enabling efficient data lifecycle management.

Nutanix Data Lens is currently offered through a “Freemium” licensing model, consisting of two tiers:

1. “Free Tier” comprises limited capabilities that are available perpetually free for NUS Pro customers
2. “Premium Tier” comprises extended capabilities, including Ransomware security, and is licensed on a per TiB basis for all NUS customers.

Self-service onboarding for current Nutanix Unified Storage Customers through [My Nutanix Portal](#).

**NOTE:**

- For more information **Nutanix Data Lens (NDL)**, please visit <https://www.nutanix.com/products/cloud-platform/software-options#nus>
- For more information about Nutanix Cloud Platform software options, please visit <https://www.nutanix.com/products/cloud-platform/software-options>
- Please note that the Federal Support program is reserved for US Federal accounts. US Federal accounts must select Federal Support Tier for the order to be fulfilled. If a non-Federal account selects a Federal Support program, Nutanix may not fulfill the order. Additionally, Nutanix's Mixed Support Level Guidelines(<https://www.nutanix.com/support-services/product-support/support-policies-and-faqs?show=accordion-4>) requires all software assets within a cluster to have the same support level, else software support will default to the lower option.
- Sellers in the Federal space need to ensure they have the Federal Support SKU's on the quote and order. All orders without the Federal Support SKU's will be rejected by Nutanix. Refer this Knowledge base article for more info: <https://compute.kb.cisco.com/article/nutanix-support-for-federal-customers.html>

**Table 29.6 Nutanix Data Lens (NDL)**

Product ID (PID)	PID Description
<b>NDL</b>	
NT-NDL-PR	Nutanix Data Lens as a hosted service including Production Support for 1 TiB
NT-NDL-FP	Nutanix Data Lens as a hosted service incl Fed Production Support for 1 TiB

Table 29.6.a Nutanix Data Lens Allowed Capacity

Nutanix Data Lens	Nutanix Data Lens Support Tier	Storage Capacity Allowed (TIB)
<b>NDL</b>	<b>Production Federal Production</b>	1-50
		75
		100
		150
		200
		250
		300
		350
		400
		450
		500
		550
		600
		700
		800
		900
		1000
		1200
		1400
		1600
1800		
2000		
2200		
2400		
2600		
2800		
3000		

**(8) End User Computing (EUC):**

Per user model offers hybrid cloud infrastructure capabilities appropriate for on-prem virtual desktop infrastructure (VDI) and Desktop as a Service (DaaS) use cases with pricing based on a Maximum Concurrent User basis (maximum number of provisioned end-user VMs). EUC per user is an alternative to the core-based NCI licensing option and is designed to provide simple, transparent licensing for all VDI users, regardless of the underlying hardware, hypervisor, or cloud.

- **Agnostic:** Works with any EUC management platform including Citrix Virtual Apps & Desktops and VMware Horizon
- **Term license:** Term license must run on a dedicated software licensed VDI cluster with no core-based licensing. Mixing of non-VDI workloads is not supported
- **Unified Storage:** Built-in and also available as a per TiB base add-on
- No additional license cost for DR site
- Portable across on-premises and public cloud, public cloud use requires Ultimate edition
- Available in Starter, Pro, and Ultimate editions
- Cloud Native and Database Service Add-ons not available with NCI EUC. Advanced Replication and Security Add-on features require NCI Ultimate edition

	EUC STARTER	EUC PROFESSIONAL	VDI ULTIMATE
NCI Feature Set	Everything in NCI Starter	Everything in NCI Professional	Everything in NCI Ultimate
Nutanix Unified Storage	1 TiB Free Capacity	50 GB Per User	100GB Per User

**NOTE:**

- For more information on End User Computing (EUC), please visit <https://www.nutanix.com/solutions/end-user-computing>
- For more information about Nutanix Cloud Platform software options, please visit <https://www.nutanix.com/products/cloud-platform/software-options>
- For ‘PURE” EUC/VDI environment, there is no NCI license required.
- If the end user wants to run a mixed workload on same server (virtual machines that are not part of the VDI environment), NCI license is required.
- Please note that the Federal Support program is reserved for US Federal accounts. US Federal accounts must select Federal Support Tier for the order to be fulfilled. If a non-Federal account selects a Federal Support program, Nutanix may not fulfill the order. Additionally, Nutanix’s Mixed Support Level Guidelines(<https://www.nutanix.com/support-services/product-support/support-policies-and-faqs?show=accordion-4>) requires all software assets within a cluster to have the same support level, else software support will default to the lower option.
- Sellers in the Federal space need to ensure they have the Federal Support SKU's on the quote and order. All orders without the Federal Support SKU's will be rejected by Nutanix. Refer this Knowledge base article for more info: <https://compute.kb.cisco.com/article/nutanix-support-for-federal-customers.html>



**Table 29.7 End User Computing (EUC)**

Product ID (PID)	PID Description
<b>STR - STARTER</b>	
NT-EUC-STR-PR	Subscription, End User Computing (EUC) Starter Software License & Production Software Support Service for 1 User
NT-EUC-STR-MC	Subscription, End User Computing (EUC) Starter Software License & Mission Critical Software Support Service for 1 User
NT-EUC-STR-FP	Subscription, End User Computing (EUC) Starter Software License & Federal Production Software Support Service for 1 User
NT-EUC-STR-FM	Subscription, End User Computing (EUC) Starter Software License & Federal Mission Critical Software Support Service for 1 User
<b>PRO- PROFESSIONAL</b>	
NT-EUC-PRO-PR	Subscription, End User Computing (EUC) Pro Software License & Production Software Support Service for 1 User
NT-EUC-PRO-MC	Subscription, End User Computing (EUC) Pro Software License & Mission Critical Software Support Service for 1 User
NT-EUC-PRO-FP	Subscription, End User Computing (EUC) Pro Software License & Federal Production Software Support Service for 1 User
NT-EUC-PRO-FM	Subscription, End User Computing (EUC) Pro Software License & Federal Mission Critical Software Support Service for 1 User
<b>ULT - ULTIMATE</b>	
NT-EUC-ULT-PR	Subscription, End User Computing (EUC) Ultimate Software License & Production Software Support Service for 1 User
NT-EUC-ULT-MC	Subscription, End User Computing (EUC) Ultimate Software License & Mission Critical Software Support Service for 1 User
NT-EUC-ULT-FP	Subscription, End User Computing (EUC) Ultimate Software License & Federal Production Software Support Service for 1 User
NT-EUC-ULT-FM	Subscription, End User Computing (EUC) Ultimate Software License & Federal Mission Critical Software Support Service for 1 User

*Table 32.0, Nutanix Software NCI, NCI-D, NCI-Edge, EUC, NCP (NCI-PRO), NCP (NCI-ULT) 1 YEAR SUBSCRIPTION with professional services PID Mapping*

*Table 32.1, Nutanix Software NCI, NCI-D, NCI-Edge, EUC, NCP (NCI-PRO), NCP (NCI-ULT) 3 YEAR SUBSCRIPTION with professional services PID Mapping*

## Professional Services PIDs and Description

### (1) NCI Design Workshop:

The Nutanix Cloud Infrastructure (NCI) Design Workshop offers IT teams in-depth and practical guidance to create a comprehensive design for on-premises NCI clusters. It covers various aspects such as scalability, functionality, integration, and operational needs. This workshop is beneficial during the Design stage of a Hybrid Multicloud journey, especially for complex solutions that involve third-party applications and automation.



#### NOTE:

- For more information on NCI Design workshop, please visit - <https://www.nutanix.com/content/dam/nutanix/resources/service-descriptions/sd-nci-design-workshop.pdf>
- For more information on Cisco version of Nutanix Professional services, please visit - <https://www.nutanix.com/content/dam/nutanix/resources/service-descriptions/professional-services-service-descriptions-cisco.pdf>

Table 30.0 NCI Design Workshop

Nutanix Software Product/Edition	Cisco Product PID	Cisco PID Description PS Offer Name - PS Offer Edition - PS Offer Option - Base/Variable	Nutanix PS Edition	Nutanix PS Option
NCI Starter	NT-W-DS-STR	NCI Design Workshop - Starter - Workshop Only	Starter	Workshop Only
NCI Starter	NT-W-DS-STR-ED	NCI Design Workshop - Starter - Enhanced Doc	Starter	Enhanced Documentation
NCI Starter	NT-W-DS-STR-SD	NCI Design Workshop - Starter - Standard Doc	Starter	Standard Documentation
NCI Pro	NT-W-DS-PRO	NCI Design Workshop - Pro - Workshop Only	Pro	Workshop Only
NCI Pro	NT-W-DS-PRO-ED	NCI Design Workshop - Pro - Standard Doc	Pro	Standard Documentation
NCI Pro	NT-W-DS-PRO-SD	NCI Design Workshop - Pro - Enhanced Doc	Pro	Enhanced Documentation
NCI Ultimate	NT-W-DS-ULT-ED	NCI Design Workshop - Ultimate - Enhanced Doc	Ultimate	Enhanced Documentation
NCI Ultimate	NT-W-DS-ULT-SD	NCI Design Workshop - Ultimate - Standard Doc	Ultimate	Standard Documentation

*Table 32.0, Nutanix Software NCI, NCI-D, NCI-Edge, EUC, NCP (NCI-PRO), NCP (NCI-ULT) 1 YEAR SUBSCRIPTION with professional services PID Mapping*

*Table 32.1, Nutanix Software NCI, NCI-D, NCI-Edge, EUC, NCP (NCI-PRO), NCP (NCI-ULT) 3 YEAR SUBSCRIPTION with professional services PID Mapping*

(2) NCI Cluster Deployment or Expansion:

The Nutanix Cloud Infrastructure (NCI) Cluster Deployment or Expansion accelerates the deployment of hybrid cloud infrastructure to support any application and workload. Highly skilled consultants can deploy on-premises NCI clusters or dedicated Nutanix Unified Storage (NUS) clusters. The clusters can be deployed to various supported hardware platforms, regardless of whether it's Nutanix, our OEM partners, or other platform providers. This offer is ideal for the Deploy stage of the Hybrid Multicloud journey.



**NOTE:**

- For more information on NCI Cluster deployment and expansion workshop, please visit - <https://www.nutanix.com/content/dam/nutanix/resources/service-descriptions/sd-nci-cluster-deployment-or-expansion.pdf>
- For more information on Cisco version of Nutanix Professional services, please visit - <https://www.nutanix.com/content/dam/nutanix/resources/service-descriptions/professional-services-service-descriptions-cisco.pdf>

Table 30.1 NCI Cluster Deployment or Expansion

Nutanix Software Product/Edition	Cisco Product PID	Cisco PID Description PS Offer Name - PS Offer Edition - PS Offer Option - Base/Variable	Nutanix PS Edition	Nutanix PS Option
NCI Starter	NT-S-DP-STR-AVB	NCI Cluster Deployment or Expansion - Starter - AHV - Base	Starter	AHV Nodes
NCI Starter	NT-S-DP-STR-AVV	NCI Cluster Deployment or Expansion - Starter - AHV - Var	Starter	AHV Nodes
NCI Starter	NT-S-DP-STR-EXB	NCI Cluster Deployment or Expansion - Starter - ESX - Base	Starter	ESX Nodes
NCI Starter	NT-S-DP-STR-EXV	NCI Cluster Deployment or Expansion - Starter - ESX - Var	Starter	ESX Nodes
NCI Pro	NT-S-DP-PRO-AV-SB	NCI Cluster Deployment or Expansion - Starter - AHV - Base	Starter	AHV Nodes
NCI Pro	NT-S-DP-PRO-AV-SV	NCI Cluster Deployment or Expansion - Starter - AHV - Var	Starter	AHV Nodes
NCI Pro	NT-S-DP-PRO-EX-SV	NCI Cluster Deployment or Expansion - Starter - ESX - Var	Starter	ESX Nodes
NCI Pro	NT-S-DP-PRO-EX-SB	NCI Cluster Deployment or Expansion - Starter - ESX - Base	Starter	ESX Nodes
NCI Pro	NT-S-DP-PRO-AV-PB	NCI Cluster Deployment or Expansion - Pro - AHV - Base	Pro	AHV Nodes
NCI Pro	NT-S-DP-PRO-AV-PV	NCI Cluster Deployment or Expansion - Pro - AHV - Var	Pro	AHV Nodes
NCI Pro	NT-S-DP-PRO-EX-PB	NCI Cluster Deployment or Expansion - Pro - ESX - Base	Pro	ESX Nodes
NCI Pro	NT-S-DP-PRO-EX-PV	NCI Cluster Deployment or Expansion - Pro - ESX - Var	Pro	ESX Nodes

**Table 30.1 NCI Cluster Deployment or Expansion**

NCI Ultimate	NT-S-DP-ULT-AV-SB	NCI Cluster Deployment or Expansion - Starter - AHV - Base	Starter	AHV Nodes
NCI Ultimate	NT-S-DP-ULT-AV-SV	NCI Cluster Deployment or Expansion - Starter - AHV - Var	Starter	AHV Nodes
NCI Ultimate	NT-S-DP-ULT-EX-SB	NCI Cluster Deployment or Expansion - Starter - ESX - Base	Starter	ESX Nodes
NCI Ultimate	NT-S-DP-ULT-EX-SV	NCI Cluster Deployment or Expansion - Starter - ESX - Var	Starter	ESX Nodes
NCI Ultimate	NT-S-DP-ULT-AV-PB	NCI Cluster Deployment or Expansion - Pro - AHV - Base	Pro	AHV Nodes
NCI Ultimate	NT-S-DP-ULT-AV-PV	NCI Cluster Deployment or Expansion - Pro - AHV - Var	Pro	AHV Nodes
NCI Ultimate	NT-S-DP-ULT-EX-PB	NCI Cluster Deployment or Expansion - Pro - ESX - Base	Pro	ESX Nodes
NCI Ultimate	NT-S-DP-ULT-EX-PV	NCI Cluster Deployment or Expansion - Pro - ESX - Var	Pro	ESX Nodes
NCI Ultimate	NT-S-DP-ULT-AV-UB	NCI Cluster Deployment or Expansion- Ultimate - AHV - Base	Ultimate	AHV Nodes
NCI Ultimate	NT-S-DP-ULT-AV-UV	NCI Cluster Deployment or Expansion- Ultimate - AHV - Var	Ultimate	AHV Nodes
NCI Ultimate	NT-S-DP-ULT-EX-UB	NCI Cluster Deployment or Expansion- Ultimate - ESX - Base	Ultimate	ESX Nodes
NCI Ultimate	NT-S-DP-ULT-EX-UV	NCI Cluster Deployment or Expansion- Ultimate - ESX - Var	Ultimate	ESX Nodes

*Table 32.0, Nutanix Software NCI, NCI-D, NCI-Edge, EUC, NCP (NCI-PRO), NCP (NCI-ULT) 1 YEAR SUBSCRIPTION with professional services PID Mapping*

*Table 32.1, Nutanix Software NCI, NCI-D, NCI-Edge, EUC, NCP (NCI-PRO), NCP (NCI-ULT) 3 YEAR SUBSCRIPTION with professional services PID Mapping*

**(3) Virtual Machine Migration Workshop:**

The Virtual Machine Migration Workshop offers IT teams in-depth and practical guidance to create a comprehensive virtual machine migration plan for migrating virtual machines to Nutanix Cloud Infrastructure (NCI). This offer is ideal for the Migrate state of a Hybrid Multicloud journey.



**NOTE:**

- For more information on Virtual Machine Migration Workshop, please visit - <https://www.nutanix.com/content/dam/nutanix/resources/service-descriptions/sd-virtual-machine-migration-workshop.pdf>
- For more information on Cisco version of Nutanix Professional services, please visit - <https://www.nutanix.com/content/dam/nutanix/resources/service-descriptions/professional-services-service-descriptions-cisco.pdf>

**Table 30.2 Virtual Machine Migration Workshop**

Nutanix Software Product/Edition	Cisco Product PID	Cisco PID Description PS Offer Name - PS Offer Edition - PS Offer Option - Base/Variable	Nutanix PS Edition	Nutanix PS Option
NCI Starter	NT-W-MG-STR-SD	Virtual Machine Migration Workshop - Standard Doc	None	Standard Documentation
NCI Starter	NT-W-MG-STR-ED	Virtual Machine Migration Workshop - Enhanced Doc	None	Enhanced Documentation
NCI Pro	NT-W-MG-PRO-SD	Virtual Machine Migration Workshop - Standard Doc	None	Standard Documentation
NCI Pro	NT-W-MG-PRO-ED	Virtual Machine Migration Workshop - Enhanced Doc	None	Enhanced Documentation
NCI Ultimate	NT-W-MG-ULT-SD	Virtual Machine Migration Workshop - Standard Doc	None	Standard Documentation
NCI Ultimate	NT-W-MG-ULT-ED	Virtual Machine Migration Workshop - Enhanced Doc	None	Enhanced Documentation

*Table 32.0, Nutanix Software NCI, NCI-D, NCI-Edge, EUC, NCP (NCI-PRO), NCP (NCI-ULT) 1 YEAR SUBSCRIPTION with professional services PID Mapping*

*Table 32.1, Nutanix Software NCI, NCI-D, NCI-Edge, EUC, NCP (NCI-PRO), NCP (NCI-ULT) 3 YEAR SUBSCRIPTION with professional services PID Mapping*

**(4) Virtual Machine Migration:**

Virtual machine (VM) Migration offers IT teams strong domain expertise to migrate virtual machines to Nutanix Cloud Infrastructure (NCI) per the customer-provided migration plan. This offer is ideal for the Migrate stage of a Hybrid Multicloud journey

**NOTE:**

- For more information on Virtual Machine Migration, please visit - <https://www.nutanix.com/content/dam/nutanix/resources/service-descriptions/sd-virtual-machine-migration.pdf>
- For more information on Cisco version of Nutanix Professional services, please visit - <https://www.nutanix.com/content/dam/nutanix/resources/service-descriptions/professional-services-service-descriptions-cisco.pdf>

**Table 30.3 Virtual Machine Migration**

Nutanix Software Product/Edition	Cisco Product PID	Cisco PID Description PS Offer Name - PS Offer Edition - PS Offer Option - Base/Variable	Nutanix PS Edition	Nutanix PS Option
NCI Starter	NT-S-MG-VM-STR-AVB	Virtual Machine Migration - From AHV - Base	None	From AHV
NCI Starter	NT-S-MG-VM-STR-AVV	Virtual Machine Migration - From AHV - Var	None	From AHV
NCI Starter	NT-S-MG-VM-STR-EXB	Virtual Machine Migration - From ESX - Base	None	From ESX
NCI Starter	NT-S-MG-VM-STR-EXV	Virtual Machine Migration - From ESX - Var	None	From ESX
NCI Pro	NT-S-MG-VM-PRO-AVB	Virtual Machine Migration - From AHV - Base	None	From AHV
NCI Pro	NT-S-MG-VM-PRO-AVV	Virtual Machine Migration - From AHV - Var	None	From AHV
NCI Pro	NT-S-MG-VM-PRO-EXB	Virtual Machine Migration - From ESX - Base	None	From ESX
NCI Pro	NT-S-MG-VM-PRO-EXV	Virtual Machine Migration - From ESX - Var	None	From ESX
NCI Ultimate	NT-S-MG-VM-ULT-AVB	Virtual Machine Migration - From AHV - Base	None	From AHV
NCI Ultimate	NT-S-MG-VM-ULT-AVV	Virtual Machine Migration - From AHV - Var	None	From AHV
NCI Ultimate	NT-S-MG-VM-ULT-EXB	Virtual Machine Migration - From ESX - Base	None	From ESX
NCI Ultimate	NT-S-MG-VM-ULT-EXV	Virtual Machine Migration - From ESX - Var	None	From ESX

*Table 32.0, Nutanix Software NCI, NCI-D, NCI-Edge, EUC, NCP (NCI-PRO), NCP (NCI-ULT) 1 YEAR SUBSCRIPTION with professional services PID Mapping*

*Table 32.1, Nutanix Software NCI, NCI-D, NCI-Edge, EUC, NCP (NCI-PRO), NCP (NCI-ULT) 3 YEAR SUBSCRIPTION with professional services PID Mapping*

(5) NCM Self-Service Design Workshop:

The Nutanix Cloud Management (NCM) Self-Service Design Workshop offers automation teams in-depth and practical guidance to create a comprehensive design for application-centric infrastructure automation and lifecycle management (LCM) platforms to streamline and accelerate application development. This workshop is beneficial during the Design stage of a Hybrid Multicloud journey.



**NOTE:**

- For more information on Nutanix Cloud Management (NCM) Self-Service Design Workshop, please visit - <https://www.nutanix.com/content/dam/nutanix/resources/datasheets/professional-services-service-descriptions.pdf>
- For more information on Cisco version of Nutanix Professional services, please visit - <https://www.nutanix.com/content/dam/nutanix/resources/service-descriptions/professional-services-service-descriptions-cisco.pdf>

Table 30.4 NCM Self-Service Design Workshop

Nutanix Software Product/Edition	Cisco Product PID	Cisco PID Description PS Offer Name - PS Offer Edition - PS Offer Option - Base/Variable	Nutanix PS Edition	Nutanix PS Option
NCM Pro	NT-W-SSD-PRO-SD-S	NCM Self-Service Design Workshop - Starter - Standard Doc	Starter	Standard Documentation
NCM Pro	NT-W-SSD-PRO-ED-S	NCM Self-Service Design Workshop - Starter - Enhanced Doc	Starter	Enhanced Documentation
NCM Pro	NT-W-SSD-PRO-SD-P	NCM Self-Service Design Workshop - Pro - Standard Doc	Pro	Standard Documentation
NCM Pro	NT-W-SSD-PRO-ED-P	NCM Self-Service Design Workshop - Pro - Enhanced Doc	Pro	Enhanced Documentation
NCM Ultimate	NT-W-SSD-ULT-SD-S	NCM Self-Service Design Workshop - Starter - Standard Doc	Starter	Standard Documentation
NCM Ultimate	NT-W-SSD-ULT-ED-S	NCM Self-Service Design Workshop - Starter - Enhanced Doc	Starter	Enhanced Documentation
NCM Ultimate	NT-W-SSD-ULT-SD-P	NCM Self-Service Design Workshop - Pro - Standard Doc	Pro	Standard Documentation
NCM Ultimate	NT-W-SSD-ULT-ED-P	NCM Self-Service Design Workshop - Pro - Enhanced Doc	Pro	Enhanced Documentation

*Table 33.0, Nutanix Software NCM STR 1 YEAR SUBSCRIPTION with professional services PID Mapping*

*Table 33.1, Nutanix Software NCM STR 3 YEAR AND ABOVE SUBSCRIPTION with Professional Services PID Mapping*

*Table 34, Nutanix Software NCM PRO, NCM ULT, NCP (NCM-PRO), NCP (NCM-ULT) 1 YEAR AND 3 YEAR & ABOVE SUBSCRIPTION with Professional services*

**(6) NCM Intelligent Operations Design:**

The Nutanix Cloud Management (NCM) Intelligent Operations Design Workshop offers IT teams in-depth and practical guidance to create a comprehensive design for Nutanix X-Play automation and playbooks to automate common tasks.

**NOTE:**

- For more information on NCM Intelligent Operations Design Workshop, please visit - <https://www.nutanix.com/content/dam/nutanix/resources/service-descriptions/sd-ncm-intelligent-operations-design.pdf>
- For more information on Cisco version of Nutanix Professional services, please visit - <https://www.nutanix.com/content/dam/nutanix/resources/service-descriptions/professional-services-service-descriptions-cisco.pdf>

**Table 30.5 NCM Intelligent Operations Design Workshop**

Nutanix Software Product/Edition	Cisco Product PID	Cisco PID Description PS Offer Name - PS Offer Edition - PS Offer Option - Base/Variable	Nutanix PS Edition	Nutanix PS Option
NCM Starter	NT-W-OD-STR-SD	NCM Intelligent Operations Design Workshop - Standard Doc	None	Standard Documentation
NCM Starter	NT-W-OD-STR-ED	NCM Intelligent Operations Design Workshop - Enhanced Doc	None	Enhanced Documentation
NCM Pro	NT-W-OD-PRO-SD	NCM Intelligent Operations Design Workshop - Standard Doc	None	Standard Documentation
NCM Pro	NT-W-OD-PRO-ED	NCM Intelligent Operations Design Workshop - Enhanced Doc	None	Enhanced Documentation
NCM Ultimate	NT-W-OD-ULT-SD	NCM Intelligent Operations Design Workshop - Standard Doc	None	Standard Documentation
NCM Ultimate	NT-W-OD-ULT-ED	NCM Intelligent Operations Design Workshop - Enhanced Doc	None	Enhanced Documentation

*Table 33.0, Nutanix Software NCM STR 1 YEAR SUBSCRIPTION with professional services PID Mapping*

*Table 33.1, Nutanix Software NCM STR 3 YEAR AND ABOVE SUBSCRIPTION with Professional Services PID Mapping*

*Table 34, Nutanix Software NCM PRO, NCM ULT, NCP (NCM-PRO), NCP (NCM-ULT) 1 YEAR AND 3 YEAR & ABOVE SUBSCRIPTION with Professional services*



**(7) NCM Intelligent Operations Deployment:**

The Nutanix Cloud Management (NCM) Intelligent Operations Deployment accelerates the deployment of Nutanix X-Play automation and playbooks to automate common tasks with in-depth expertise from highly skilled consultants.



**NOTE:**

- For more information on NCM Intelligent Operations Deployment Workshop, please visit - <https://www.nutanix.com/content/dam/nutanix/resources/service-descriptions/sd-ncm-intelligent-operations-deployment.pdf>
- For more information on Cisco version of Nutanix Professional services, please visit - <https://www.nutanix.com/content/dam/nutanix/resources/service-descriptions/professional-services-service-descriptions-cisco.pdf>

**Table 30.6 NCM Intelligent Operations Deployment**

Nutanix Software Product/Edition	Cisco Product PID	Cisco PID Description PS Offer Name - PS Offer Edition - PS Offer Option - Base/Variable	Nutanix PS Edition	Nutanix PS Option
NCM Starter	NT-S-OP-STR	NCM Intelligent Operations Deployment	None	None
NCM Pro	NT-S-OP-PRO	NCM Intelligent Operations Deployment	None	None
NCM Ultimate	NT-S-OP-ULT	NCM Intelligent Operations Deployment	None	None

*Table 33.0, Nutanix Software NCM STR 1 YEAR SUBSCRIPTION with professional services PID Mapping*  
*Table 33.1, Nutanix Software NCM STR 3 YEAR AND ABOVE SUBSCRIPTION with Professional Services PID Mapping*

*Table 34, Nutanix Software NCM PRO, NCM ULT, NCP (NCM-PRO), NCP (NCM-ULT) 1 YEAR AND 3 YEAR & ABOVE SUBSCRIPTION with Professional services*

**(8) FastTrack for NCM Self-Service:**

FastTrack for Nutanix Cloud Manager (NCM) Self-Service accelerates the deployment and configuration of NCM Self-Service, which streamlines how teams manage, deploy, and scale applications across hybrid clouds with self-service, automation, and centralized role-based governance, with expertise from highly skilled automation consultants.

**NOTE:**

- For more information on Fast Track for NCM Self-Service, please visit - <https://www.nutanix.com/content/dam/nutanix/resources/service-descriptions/sd-ncm-intelligent-operations-deployment.pdf>
- For more information on Cisco version of Nutanix Professional services, please visit - <https://www.nutanix.com/content/dam/nutanix/resources/service-descriptions/professional-services-service-descriptions-cisco.pdf>

**Table 30.7 FastTrack for NCM Self-Service**

Nutanix Software Product/Edition	Cisco Product PID	Cisco PID Description PS Offer Name - PS Offer Edition - PS Offer Option - Base/Variable	Nutanix PS Edition	Nutanix PS Option
NCM Pro	NT-F-PRO-SS	FastTrack for NCM Self-Service	None	None
NCM Ultimate	NT-F-ULT-SS	FastTrack for NCM Self-Service	None	None

*Table 33.0, Nutanix Software NCM STR 1 YEAR SUBSCRIPTION with professional services PID Mapping*

*Table 33.1, Nutanix Software NCM STR 3 YEAR AND ABOVE SUBSCRIPTION with Professional Services PID Mapping*

*Table 34, Nutanix Software NCM PRO, NCM ULT, NCP (NCM-PRO), NCP (NCM-ULT) 1 YEAR AND 3 YEAR & ABOVE SUBSCRIPTION with Professional services*

**(9) FastTrack for NCM Cost Governance:**

The FastTrack for Nutanix Cloud Management (NCM) Cost Governance accelerates the onboarding of deep visibility and rich analytics detailing cloud consumption patterns along with one-click cost optimization across cloud environments with expertise from highly skilled consultants. IT teams can choose to onboard on-premises Nutanix Cloud Infrastructure (NCI) clusters or a public cloud platform.



**NOTE:**

- For more information on Fast Track for NCM Cost Governance, please visit - <https://www.nutanix.com/content/dam/nutanix/resources/service-descriptions/sd-ncm-intelligent-operations-deployment.pdf>
- For more information on Cisco version of Nutanix Professional services, please visit - <https://www.nutanix.com/content/dam/nutanix/resources/service-descriptions/professional-services-service-descriptions-cisco.pdf>

**Table 30.8 FastTrack for NCM Cost Governance**

Nutanix Software Product/Edition	Cisco Product PID	Cisco PID Description PS Offer Name - PS Offer Edition - PS Offer Option - Base/Variable	Nutanix PS Edition	Nutanix PS Option
NCM Pro	NT-F-PRO-CG	FastTrack for NCM Cost Governance	None	None
NCM Ultimate	NT-F-ULT-CG	FastTrack for NCM Cost Governance	None	None

*Table 33.0, Nutanix Software NCM STR 1 YEAR SUBSCRIPTION with professional services PID Mapping*

*Table 33.1, Nutanix Software NCM STR 3 YEAR AND ABOVE SUBSCRIPTION with Professional Services PID Mapping*

*Table 34, Nutanix Software NCM PRO, NCM ULT, NCP (NCM-PRO), NCP (NCM-ULT) 1 YEAR AND 3 YEAR & ABOVE SUBSCRIPTION with Professional services*

**(10) Nutanix Services Flexible Credits:**

Nutanix Flex Credits provide a credits program for purchasing Nutanix Professional Services. This program provides the flexibility to utilize your budget cycles to pre-buy credits for future use of Nutanix Professional Services and training via redemption of credits. Within the terms of validity of your Flex Credits, use the credits for the portfolio of Nutanix Professional Services including Consulting, Resident, Technical Account Manager, and Education.

**NOTE:**

- For more information on Nutanix Services Flexible Credits, please visit - <https://www.nutanix.com/content/dam/nutanix/resources/service-descriptions/sd-ncm-intelligent-operations-deployment.pdf>
- For more information on Cisco version of Nutanix Professional services, please visit - <https://www.nutanix.com/content/dam/nutanix/resources/service-descriptions/professional-services-service-descriptions-cisco.pdf>

**Table 30.9 Nutanix Flexible Credits**

Nutanix Software Product/Edition	Cisco Product PID	Cisco PID Description PS Offer Name - PS Offer Edition - PS Offer Option - Base/Variable	Nutanix PS Edition	Nutanix PS Option
All	NT-FLEX-CST-CR	Nutanix Services Flexible Credits	None	None

*Table 33.0, Nutanix Software NCM STR 1 YEAR SUBSCRIPTION with professional services PID Mapping*

*Table 33.1, Nutanix Software NCM STR 3 YEAR AND ABOVE SUBSCRIPTION with Professional Services PID Mapping*

*Table 34, Nutanix Software NCM PRO, NCM ULT, NCP (NCM-PRO), NCP (NCM-ULT) 1 YEAR AND 3 YEAR & ABOVE SUBSCRIPTION with Professional services*

## Nutanix Support:

Table 31 Nutanix Support

Product ID (PID)	PID Description
<b>Nutanix Support</b>	
SVS-NT-SUP	Entitlement ONLY for Nutanix Cloud Infrastructure SW

## Software With Professional Services PID Mapping



**NOTE:** Recommended to select the matching/higher level of service options for the subscribed software. For example: If ULT (Ultimate) software is selected, recommended to choose the ULT services from the below columns. However, it is allowed to select the lower version of the services.

Table 32.0 Nutanix Software NCI, NCI-D, NCI-Edge, EUC, NCP (NCI-PRO), NCP (NCI-ULT) 1 YEAR SUBSCRIPTION with professional services PID Mapping

Software PIDs	Mandatory Professional Services PIDs	
	NCI Design Workshop (select one service)	NCI Cluster Deployment or Expansion (select a Pair of service)
<b>STR:</b> <b>A) NCI</b> NT-NCI-STR-PR NT-NCI-STR-MC NT-NCI-STR-FP NT-NCI-STR-FM  <b>B) NCI-D</b> NT-NCI-D-STR-PR NT-NCI-D-STR-MC NT-NCI-D-STR-FP NT-NCI-D-STR-FM  <b>C) NCI-Edge</b> NT-NCI-E-STR-PR NT-NCI-E-STR-MC NT-NCI-E-STR-FP NT-NCI-E-STR-FM  <b>D) EUC</b> NT-EUC-STR-PR NT-EUC-STR-MC NT-EUC-STR-FP NT-EUC-STR-FM  <b>PRO:</b> <b>A) NCI</b> NT-NCI-PRO-PR NT-NCI-PRO-MC NT-NCI-PRO-FP NT-NCI-PRO-FM	<b>STR:</b> NT-W-DS-STR NT-W-DS-STR-SD NT-W-DS-STR-ED  <b>PRO:</b> NT-W-DS-PRO NT-W-DS-PRO-SD NT-W-DS-PRO-ED  <b>ULT:</b> NT-W-DS-ULT-SD NT-W-DS-ULT-ED	<b>STR:</b> NT-S-DP-STR-AVB and NT-S-DP-STR-AVV or NT-S-DP-STR-EXB and NT-S-DP-STR-EXV  <b>PRO:</b> NT-S-DP-PRO-AV-SB and NT-S-DP-PRO-AV-SV or NT-S-DP-PRO-EX-SB and NT-S-DP-PRO-EX-SV or NT-S-DP-PRO-AV-PB and NT-S-DP-PRO-AV-PV or NT-S-DP-PRO-EX-PB and NT-S-DP-PRO-EX-PV  <b>ULT:</b> NT-S-DP-ULT-AV-SB and NT-S-DP-ULT-AV-SV or NT-S-DP-ULT-EX-SB and NT-S-DP-ULT-EX-SV or NT-S-DP-ULT-AV-PB and NT-S-DP-ULT-AV-PV or NT-S-DP-ULT-EX-PB and NT-S-DP-ULT-EX-PV or NT-S-DP-ULT-AV-UB and NT-S-DP-ULT-AV-UV or NT-S-DP-ULT-EX-UB and NT-S-DP-ULT-EX-UV

Table 32.0 Nutanix Software NCI, NCI-D, NCI-Edge, EUC, NCP (NCI-PRO), NCP (NCI-ULT) 1 YEAR SUBSCRIPTION with professional services PID Mapping

<p><b>B) NCI-D</b>  NT-NCI-D-PRO-PR  NT-NCI-D-PRO-MC  NT-NCI-D-PRO-FP  NT-NCI-D-PRO-FM</p> <p><b>C) NCI-Edge</b>  NT-NCI-E-PRO-PR  NT-NCI-E-PRO-MC  NT-NCI-E-PRO-FP  NT-NCI-E-PRO-FM</p> <p><b>D) EUC</b>  NT-EUC-PRO-PR  NT-EUC-PRO-MC  NT-EUC-PRO-FP  NT-EUC-PRO-FM</p> <p><b>E) NCP (NCI-PRO)</b>  NT-NCP-NCI-PRO-PR  NT-NCP-NCI-PRO-MC  NT-NCP-NCI-PRO-FP  NT-NCP-NCI-PRO-FM</p> <p><b>ULT:</b>  <b>A) NCI</b>  NT-NCI-ULT-PR  NT-NCI-ULT-MC  NT-NCI-ULT-FP  NT-NCI-ULT-FM</p> <p><b>B) NCI-D</b>  NT-NCI-D-ULT-PR  NT-NCI-D-ULT-MC  NT-NCI-D-ULT-FP  NT-NCI-D-ULT-FM</p> <p><b>C) NCI-Edge</b>  NT-NCI-E-ULT-PR  NT-NCI-E-ULT-MC  NT-NCI-E-ULT-FP  NT-NCI-E-ULT-FM</p>		
---	--	--

Table 32.0 Nutanix Software NCI, NCI-D, NCI-Edge, EUC, NCP (NCI-PRO), NCP (NCI-ULT) 1 YEAR SUBSCRIPTION with professional services PID Mapping

<b>D) EUC</b> NT-EUC-ULT-PR NT-EUC-ULT-MC NT-EUC-ULT-FP NT-EUC-ULT-FM		
<b>E) NCP (NCI-ULT)</b> NT-NCP-NCI-ULT-PR NT-NCP-NCI-ULT-MC NT-NCP-NCI-ULT-FP NT-NCP-NCI-ULT-FM		





**NOTE:** Recommended to select the matching/higher level of service options for the subscribed software. For example: If ULT (Ultimate) software is selected, recommended to choose the ULT services from the below columns. However, it is allowed to select the lower version of the services.

**Table 32.1 Nutanix Software NCI, NCI-D, NCI-Edge, EUC, NCP (NCI-PRO), NCP (NCI-ULT) 3 YEAR SUBSCRIPTION with professional services PID Mapping**

Software PIDs	Recommended Professional Services PIDs	
	NCI Design Workshop (select one service)	NCI Cluster Deployment or Expansion (select a Pair of service)
<p><b>STR:</b></p> <p><b>A) NCI</b>                      NT-NCI-STR-PR                      NT-NCI-STR-MC                      NT-NCI-STR-FP                      NT-NCI-STR-FM</p> <p><b>B) NCI-D</b>                      NT-NCI-D-STR-PR                      NT-NCI-D-STR-MC                      NT-NCI-D-STR-FP                      NT-NCI-D-STR-FM</p> <p><b>C) NCI-Edge</b>                      NT-NCI-E-STR-PR                      NT-NCI-E-STR-MC                      NT-NCI-E-STR-FP                      NT-NCI-E-STR-FM</p> <p><b>D) EUC</b>                      NT-EUC-STR-PR                      NT-EUC-STR-MC                      NT-EUC-STR-FP                      NT-EUC-STR-FM</p> <p><b>PRO:</b></p> <p><b>A) NCI</b>                      NT-NCI-PRO-PR                      NT-NCI-PRO-MC                      NT-NCI-PRO-FP                      NT-NCI-PRO-FM</p>	<p><b>STR:</b>                      NT-W-DS-STR                      NT-W-DS-STR-SD                      NT-W-DS-STR-ED</p> <p><b>PRO:</b>                      NT-W-DS-PRO                      NT-W-DS-PRO-SD                      NT-W-DS-PRO-ED</p> <p><b>ULT:</b>                      NT-W-DS-ULT-SD                      NT-W-DS-ULT-ED</p>	<p><b>STR:</b>                      NT-S-DP-STR-AVB and NT-S-DP-STR-AVV or                      NT-S-DP-STR-EXB and N T-S-DP-STR-EXV</p> <p><b>PRO:</b>                      NT-S-DP-PRO-AV-SB and NT-S-DP-PRO-AV-SV or                      NT-S-DP-PRO-EX-SB and NT-S-DP-PRO-EX-SV or                      NT-S-DP-PRO-AV-PB and NT-S-DP-PRO-AV-PV or                      NT-S-DP-PRO-EX-PB and NT-S-DP-PRO-EX-PV</p> <p><b>ULT:</b>                      NT-S-DP-ULT-AV-SB and NT-S-DP-ULT-AV-SV or                      NT-S-DP-ULT-EX-SB and NT-S-DP-ULT-EX-SV or                      NT-S-DP-ULT-AV-PB and NT-S-DP-ULT-AV-PV or                      NT-S-DP-ULT-EX-PB and NT-S-DP-ULT-EX-PV or                      NT-S-DP-ULT-AV-UB and NT-S-DP-ULT-AV-UV or                      NT-S-DP-ULT-EX-UB and NT-S-DP-ULT-EX-UV</p>

Table 32.1 Nutanix Software NCI, NCI-D, NCI-Edge, EUC, NCP (NCI-PRO), NCP (NCI-ULT) 3 YEAR SUBSCRIPTION with professional services PID Mapping

<p><b>B) NCI-D</b>  NT-NCI-D-PRO-PR  NT-NCI-D-PRO-MC  NT-NCI-D-PRO-FP  NT-NCI-D-PRO-FM</p> <p><b>C) NCI-Edge</b>  NT-NCI-E-PRO-PR  NT-NCI-E-PRO-MC  NT-NCI-E-PRO-FP  NT-NCI-E-PRO-FM</p> <p><b>D) EUC</b>  NT-EUC-PRO-PR  NT-EUC-PRO-MC  NT-EUC-PRO-FP  NT-EUC-PRO-FM</p> <p><b>E) NCP (NCI-PRO)</b>  NT-NCP-NCI-PRO-PR  NT-NCP-NCI-PRO-MC  NT-NCP-NCI-PRO-FP  NT-NCP-NCI-PRO-FM</p> <p><b>ULT:</b>  <b>A) NCI</b>  NT-NCI-ULT-PR  NT-NCI-ULT-MC  NT-NCI-ULT-FP  NT-NCI-ULT-FM</p> <p><b>B) NCI-D</b>  NT-NCI-D-ULT-PR  NT-NCI-D-ULT-MC  NT-NCI-D-ULT-FP  NT-NCI-D-ULT-FM</p> <p><b>C) NCI-Edge</b>  NT-NCI-E-ULT-PR  NT-NCI-E-ULT-MC  NT-NCI-E-ULT-FP  NT-NCI-E-ULT-FM</p>		
---	--	--

Table 32.1 Nutanix Software NCI, NCI-D, NCI-Edge, EUC, NCP (NCI-PRO), NCP (NCI-ULT) 3 YEAR SUBSCRIPTION with professional services PID Mapping

<p><b>D) EUC</b>                  NT-EUC-ULT-PR                  NT-EUC-ULT-MC                  NT-EUC-ULT-FP                  NT-EUC-ULT-FM</p> <p><b>E) NCP (NCI-ULT)</b>                  NT-NCP-NCI-ULT-PR                  NT-NCP-NCI-ULT-MC                  NT-NCP-NCI-ULT-FP                  NT-NCP-NCI-ULT-FM</p>		
---	--	--



**NOTE:** Recommended to select the matching/higher level of service options for the subscribed software. For example: If ULT (Ultimate) software is selected, recommended to choose the ULT services from the below columns. However, it is allowed to select the lower version of the services.

Table 33.0 Nutanix Software NCM STR 1 YEAR SUBSCRIPTION with professional services PID Mapping

Software PIDs	Mandatory Professional Services PIDs	
	NCM Intelligent Operations Design (select one service)	NCM Intelligent Operations Deployment (select one service)
<b>STR:</b> <b>A) NCM</b> NT-NCM-STR-PR NT-NCM-STR-MC NT-NCM-STR-FP NT-NCM-STR-FM	<b>STR:</b> NT-W-OD-STR-SD NT-W-OD-STR-ED  <b>PRO:</b> NT-W-OD-PRO-SD NT-W-OD-PRO-ED  <b>ULT:</b> NT-W-OD-ULT-SD NT-W-OD-ULT-ED	<b>STR:</b> NT-S-OP-STR  <b>PRO:</b> NT-S-OP-PRO  <b>ULT:</b> NT-S-OP-ULT



**NOTE:** Recommended to select the matching/higher level of service options for the subscribed software. For example: If ULT (Ultimate) software is selected, recommended to choose the ULT services from the below columns. However, it is allowed to select the lower version of the services.

Table 33.1 Nutanix Software NCM STR 3 YEAR AND ABOVE SUBSCRIPTION with Professional Services PID Mapping

Software PIDs	Recommended Professional Services PIDs	
	NCM Intelligent Operations Design (select one service)	NCM Intelligent Operations Deployment (select one service)
<b>STR:</b> <b>A) NCM</b> NT-NCM-STR-PR NT-NCM-STR-MC NT-NCM-STR-FP NT-NCM-STR-FM	<b>STR:</b> NT-W-OD-STR-SD NT-W-OD-STR-ED  <b>PRO:</b> NT-W-OD-PRO-SD NT-W-OD-PRO-ED  <b>ULT:</b> NT-W-OD-ULT-SD NT-W-OD-ULT-ED	<b>STR:</b> NT-S-OP-STR  <b>PRO:</b> NT-S-OP-PRO  <b>ULT:</b> NT-S-OP-ULT



**NOTE:** Recommended to select the matching/higher level of service options for the subscribed software. For example: If ULT (Ultimate) software is selected, recommended to choose the ULT services from the below columns. However, it is allowed to select the lower version of the services.

**Table 34 Nutanix Software NCM PRO, NCM ULT, NCP (NCM-PRO), NCP (NCM-ULT) 1 YEAR AND 3 YEAR & ABOVE SUBSCRIPTION with Professional services**

Software PIDs	Mandatory Professional Services PIDs				
	NCM Self-Service DesignWorkshop (select one service)	NCM Intelligent Operations Design (select one service)	NCM Intelligent Operations Deployment (select one service)	FastTrack for NCM Self-Service (select one service)	FastTrack for NCM Cost Governance (select one service)
<b>PRO:</b> <b>A) NCM</b> NT-NCM-PRO-PR NT-NCM-PRO-MC NT-NCM-PRO-FP NT-NCM-PRO-FM  <b>B) NCP (NCM-PRO)</b> NT-NCP-NCM-PRO-PR NT-NCP-NCM-PRO-MC NT-NCP-NCM-PRO-FP NT-NCP-NCM-PRO-FM  <b>ULT:</b> <b>A) NCM</b> NT-NCM-ULT-PR NT-NCM-ULT-MC NT-NCM-ULT-FP NT-NCM-ULT-FM  <b>B) NCP (NCM-ULT)</b> NT-NCP-NCM-ULT-PR NT-NCP-NCM-ULT-MC NT-NCP-NCM-ULT-FP NT-NCP-NCM-ULT-FM	<b>PRO:</b> NT-W-SSD-PRO-SD-S NT-W-SSD-PRO-ED-S NT-W-SSD-PRO-SD-P NT-W-SSD-PRO-ED-P  <b>ULT:</b> NT-W-SSD-ULT-SD-S NT-W-SSD-ULT-ED-S NT-W-SSD-ULT-SD-P NT-W-SSD-ULT-ED-P	<b>STR:</b> NT-W-OD-STR-SD NT-W-OD-STR-ED  <b>PRO:</b> NT-W-OD-PRO-SD NT-W-OD-PRO-ED  <b>ULT:</b> NT-W-OD-ULT-SD NT-W-OD-ULT-ED	<b>STR:</b> NT-S-OP-STR  <b>PRO:</b> NT-S-OP-PRO  <b>ULT:</b> NT-S-OP-ULT	<b>PRO:</b> NT-F-PRO-SS  <b>ULT:</b> NT-F-ULT-SS	<b>PRO:</b> NT-F-PRO-CG  <b>ULT:</b> NT-F-ULT-CG



## STEP 17 CISCO INTERSIGHT (REQUIRED)

Cisco Intersight™ is a Software-as-a-Service (SaaS) hybrid cloud operations platform which delivers intelligent automation, observability, and optimization to customers for traditional and cloud-native applications and infrastructure.

Product ID (PID)	
DC-MGT-SAAS	Cisco Intersight SaaS

Select Cisco Intersight subscription option as desired from [Table 35](#)

Table 35 Cisco Intersight

Product ID (PID)	PID Description
<b>Cisco Intersight 2.0 Infrastructure Services</b>	
DC-MGT-IS-SAAS-ES SA	Infrastructure Services SaaS/CVA - Essentials
DC-MGT-IS-SAAS-AD SA	Infrastructure Services SaaS/CVA - Advantage
DC-MGT-IS-PVAPP-ES SA	Infrastructure Services PVA - Essentials
DC-MGT-IS-PVAPP-AD SA	Infrastructure Services PVA - Advantage
DC-MGT-IS-UCSD	UCS Director - 1 Server License (includes Network, Storage)
<b>Cisco Intersight Workload Optimizer (IWO) - SaaS</b>	
<b>VM Instance</b>	
DC-MGT-WO-SAAS-ES SA	Cisco Intersight Workload Optimizer SaaS - Essentials
DC-MGT-WO-SAAS-AD SA	Cisco Intersight Workload Optimizer SaaS - Advantage
DC-MGT-WO-SAAS-PR SA	Cisco Intersight Workload Optimizer SaaS - Premier
<b>VDI Instance</b>	
DC-MGT-WOD-SAAS-ES SA	Cisco Intersight Workload Optimizer SaaS VDI - Essentials
DC-MGT-WOD-SAAS-AD SA	Cisco Intersight Workload Optimizer SaaS VDI - Advantage
DC-MGT-WOD-SAAS-PR SA	Cisco Intersight Workload Optimizer SaaS VDI - Premier

---

Select Cisco Intersight support option as desired from [Table 36](#)

---

**Table 36 Cisco Intersight Support**

Product ID (PID)	PID Description
<b>Cisco Intersight Support</b>	
SVS-SSTCS-DCMGMT SA	Solution Support for DC Mgmt
SVS-L1DCS-INTER SA	CXL1 for INTERSIGHT
SVS-L2DCS-INTER SA	CXL2 for INTERSIGHT
SVS-DCM-SUPT-BAS	Basic Support for DCM



**NOTE:** An Intersight license is required for every server.

---



# SUPPLEMENTAL MATERIAL

## Block Diagram

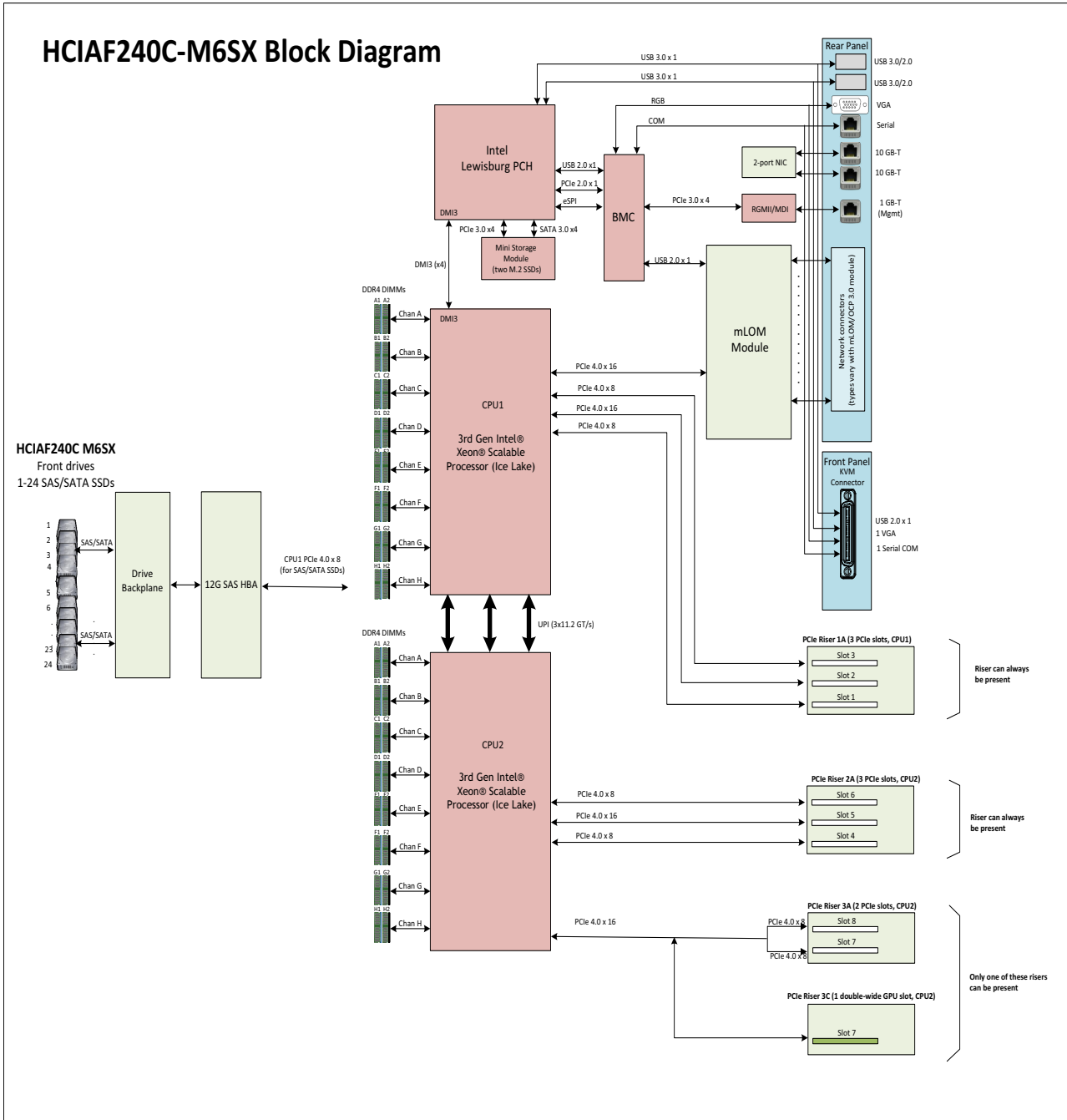

## Hyperconverged Systems

Cisco Compute Hyperconverged Systems let you unlock the full potential of hyperconvergence and adapt IT to the needs of your workloads. The systems use an end-to-end software-defined infrastructure approach, combining software-defined computing in the form of Cisco Compute Hyperconverged HCI-Series nodes; software-defined storage with the powerful Nutanix AOS Platform; and software-defined networking with the Cisco UCS fabric that will integrate smoothly with Cisco Application Centric Infrastructure (Cisco ACI). Together with a single point of connectivity and management, these technologies deliver a preintegrated and adaptable cluster with a unified pool of resources that you can quickly deploy, adapt, scale, and manage to efficiently power your applications and your business.

**Figure 5 Small Footprint Cluster Using HCIAS240C M6 All-Flash Server With Data Center Fabric Interconnect Deployment Mode**

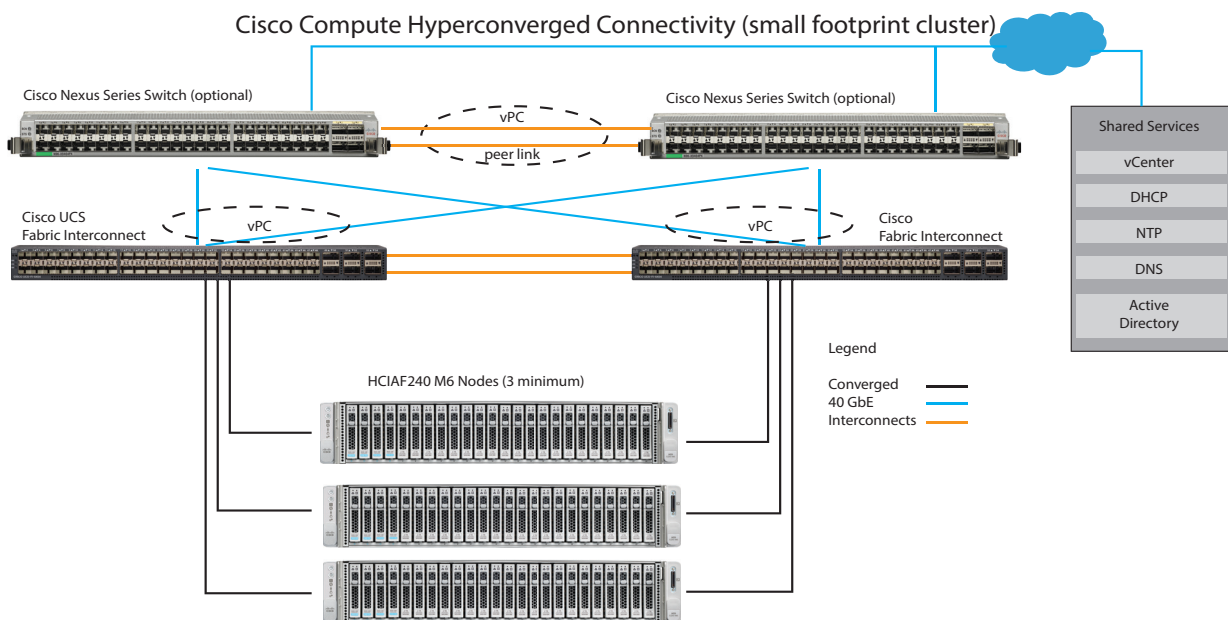

## Retrofit of Existing UCS Servers

Existing UCS servers that match the base HCI platform (C220 M6 All-Flash/C220 M6 All NVMe/C240 M6 All-Flash) can be retrofitted to support Nutanix software. UCS servers contain a software feature known as a software defined personality, enabling easy and automatic conversion between a base UCS platform and an HCI appliance supported under the Nutanix OEM program.

To prepare a server for retrofitting, confirm all installed components match all required sections of this document (e.g CPU, Memory, Drive Controller, Drives, Network Adapters, etc.). Special care should be taken to ensure compatible boot media, storage controllers, drives, and networking adapters are selected in line with this document.

For the C240 M6 All-Flash specifically, riser 1B and 3B can be physically installed as long as the drive bays remain unpopulated. Only the 24 front facing drive slots can be populated with SSDs.

Once the server hardware is confirmed to be compatible with this spec sheet, be sure to purchase the appropriate Nutanix software licenses, Intersight licenses, and professional services, as required.

The [Table 37](#) below can be used to verify drive compatibility for a new Nutanix deployment. Use the source PID (whether UCS or HX) to find the equivalent HCI PID. The table below is a generic lookup table and is not specific to this spec sheet. Therefore, once the HCI PID is determined, verify the compatibility of the drive to the specific model in the spec sheet (step 7). If a drive doesn't have an HCI PID listed, it is an end of life (EoL) drive that is supported with this solution and qualified for conversion use cases.

**Table 37 Drive compatibility for a new Nutanix deployment**

HCI Drive PID	HX Drive PID	UCS Drive PID	Other Equivalent PIDs	Drive Model
<b>NVMe</b>				
HCI-NVME4-1920 HCI-NVME4-1920-M6	HX-NVME4-1920	UCS-NVME4-1920 UCS-NVME4-1920-D	UCSX-NVME4-1920 UCSX-NVME4-1920-D	SSDPF2KX019T10
HCI-NVMEI4I1920M6	HX-NVMEI4-I1920	UCS-NVMEI4-I1920	UCSX-NVMEI4-I1920 UCSXNVMEI4I1920-D	SSDPF2KX019T9K
HCI-NVMEI4I3840M6	HX-NVMEI4-I3840 HXE-NVMEI4-I3840	UCS-NVMEI4-I3840	UCSX-NVMEI4-I3840 UCSXNVMEI4I3840-D	SSDPF2KX038T9K
HCI-NVMEI4I7680M6	HX-NVMEI4-I7680 HXE-NVMEI4-I7680	UCS-NVMEI4-I7680	UCSX-NVMEI4-I7680 UCSXNVMEI4I7680-D	SSDPF2KX076T9K
HCI-NVME-W7680M6	HX-NVMEM6-W7680	UCS-NVMEM6-W7680	UCSX-NVME-W7680-D UCSX-NVMEM6-W7680	WUS4BA176DSP3X3
HCI-NVME-W15300M6	HX-NVMEM6-W15300 HXE-NVMEM6-W15300	UCS-NVMEM6-W15300	UCSX-NVMEM6W1530 UCSX-NVMEW15300-D	WUS4BA1A1DSP3X3
HCI-NVME4-3840-M6	HX-NVME4-3840 HXE-NVME4-3840	UCS-NVME4-3840 UCS-NVME4-3840-D	UCSX-NVME4-3840 UCSX-NVME4-3840-D	SSDPF2KX038T10
HCI-NVME4-15360M6	HX-NVME4-15360 HXE-NVME4-15360	UCS-NVME4-15360 UCS-NVME4-15360-D	UCSX-NVME4-15360 UCSX-NVME4-15360D	SSDPF2KX153T10
<b>SSD</b>				

**Table 37 Drive compatibility for a new Nutanix deployment**

HCI-SD19T6S1XEVM6	HX-SD19T6S1X-EV	UCS-SD19T6S1X-EV UCS-SD19T6S1XEV-D	UCSX-SD19T6S1X-EV UCSXSD19T6S1XEV-D	MZ7L31T9HBLT
HCI-SD38T6S1XEVM6	HX-SD38T6S1X-EV HXE-SD38T6S1X-EV	UCS-SD38T6S1X-EV UCS-SD38T6S1XEV-D	UCSX-SD38T6S1X-EV UCSXSD38T6S1XEV-D	MZ7L33T8HBLT
HCI-SD76T6S1XEVM6	HX-SD76T6S1X-EV HXE-SD76T6S1X-EV	UCS-SD76T6S1X-EV UCS-SD76T6S1XEV-D	UCSX-SD76T6S1X-EV UCSXSD76T6S1XEV-D	MZ7L37T6HBLA
HCI-SD38TK1X-EVM6	HX-SD38TK1X-EV	UCS-SD38TK1X-EV UCS-SD38TK1X-EV-D	UCSX-SD38TK1X-EV UCSX-SD38TK1XEV-D	KPM6XRUG3T84
HCI-SD76TK1X-EVM6	HX-SD76TK1X-EV	UCS-SD76TK1X-EV UCS-SD76TK1X-EV-D	UCSX-SD76TK1X-EV UCSX-SD76TK1XEV-D	KPM6XRUG7T68
HCI-SD38TBKNK9-M6	HX-SD38TBKNK9	UCS-SD38TBKNK9 UCS-SD38TBKNK9-D	UCSX-SD38TBKNK9 UCSX-SD38TBKNK9-D	KPM6WRUG3T84
HCI-SD76TBKNK9-M6	HX-SD76TBKNK9	UCS-SD76TBKNK9 UCS-SD76TBKNK9-D	UCSX-SD76TBKNK9 UCSX-SD76TBKNK9-D	KPM6WRUG7T68
No HCI PID	HX-SD19T61X-EV	UCS-SD19T61X-EV	UCSX-SD19T61X-EV	PM883 (MZ7LH1T9HMLT) model only <sup>1</sup> PM863a (MZ7LM1T9HMJP) is not supported.
No HCI PID	HX-SD38T61X-EV HXE-SD38T61X-EV	UCS-SD38T61X-EV UCS-SP-38T61X-EV UCS-SP-SD-3P8T	UCSX-SD38T61X-EV	PM883 (MZ7LH3T8HMLT) and PM863a (MZ7LM3T8HMLP) models only <sup>1</sup> PM863 (MZ7LM3T8HCJM) is not supported.
No HCI PID	HX-SD38T61X-EV HXE-SD38T61X-EV	UCS-SD38T61X-EV UCS-SP-38T61X-EV UCS-SP-SD-3P8T	UCSX-SD38T61X-EV	PM883 (MZ7LH3T8HMLT) and PM863a (MZ7LM3T8HMLP) models only. <sup>1</sup> PM863 (MZ7LM3T8HCJM) is not supported.
No HCI PID	HX-SD76T61X-EV HXE-SD76T61X-EV	UCS-SD76T61X-EV	UCSX-SD76T61X-EV	PM883 (MZ7LH7T6HMLA
<b>Boot</b>				
HCI-M2-240GB-M6	HX-M2-240GB	UCS-M2-240GB UCS-M2-240GB-D	UCSX-M2-240GB UCSX-M2-240GB-D	Micron 5100/5300
HCI-M2-240G-M6	HX-M2-240G	UCS-M2-240G UCS-M2-240G-D	UCSX-M2-240G UCSX-M2-240G-D	Micron 5400
HCI-M2-I240GB-M6	HX-M2-I240GB	UCS-M2-I240GB UCS-M2-I240GB-D	UCSX-M2-I240GB UCSX-M2-I240GB-D	Solidigm/Intel SSDSCKKB240GZK

**Notes:**

1. Carefully check the actual drive installed to ensure it matches this exact model. PID identification is not sufficient to verify compatibility.

Only base PIDs are included in the table above. Spares can be ordered with (=) added to the end of a base PID.



**NOTE:** This table will be continually updated. Compatibility between drive PIDs may shift, and hence this table must be referenced regularly.

---

Some drives will require a detailed vendor & model check to confirm compatibility with Nutanix AOS software. To verify drive vendor & model, pick one of the following 3 options:

- Physically inspect the drives by removing the drive from the slot
- From UCSM CLI, run the following commands:
  - # scope server <x>
  - # scope raid-controller 1 sas
  - # show local-disk detail | egrep 'Vendor|Model|PID'
- From Intersight, navigate to the server of interest -> Inventory -> Storage Controllers -> SAS -> Physical Drives

## Serial Port Details

The pinout details of the rear RJ-45 serial port connector are shown in [Figure 6](#).

**Figure 6** Serial Port (Female RJ-45 Connector) Pinout

### Serial Port (RJ-45 Female Connector)

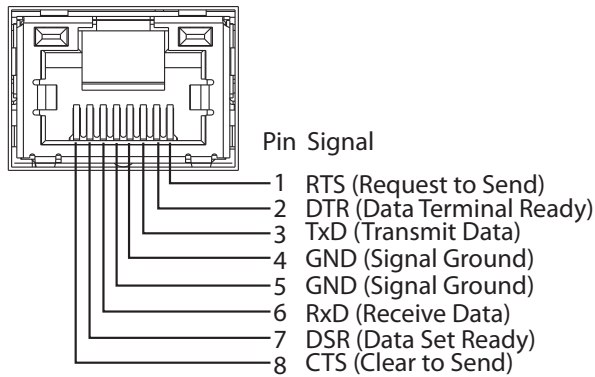

## KVM Cable

The KVM cable provides a connection into the server, providing a DB9 serial connector, a VGA connector for a monitor, and dual USB 2.0 ports for a keyboard and mouse. With this cable, you can create a direct connection to the operating system and the BIOS running on the server.

The KVM cable ordering information is listed in [Table 38](#).

**Table 38** KVM Cable

Product ID (PID)	PID Description
N20-BKVM	KVM local IO cable for UCS servers console port

**Figure 7** KVM Cable

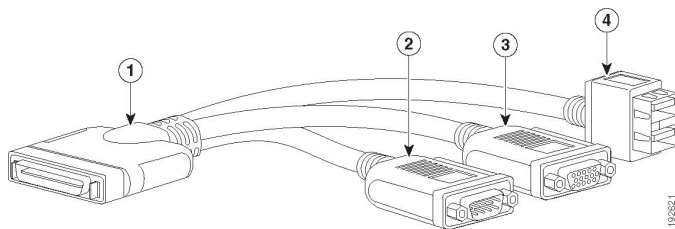

1	Connector (to server front panel)	3	VGA connector (for a monitor)
2	DB-9 serial connector	4	Two-port USB 2.0 connector (for a mouse and keyboard)

## Chassis

An internal view of the HClAF240C M6 All-Flash Server chassis with the top cover removed is shown in [Figure 8](#).

**Figure 8** HClAF240C M6 All-Flash Server With Top Cover Off

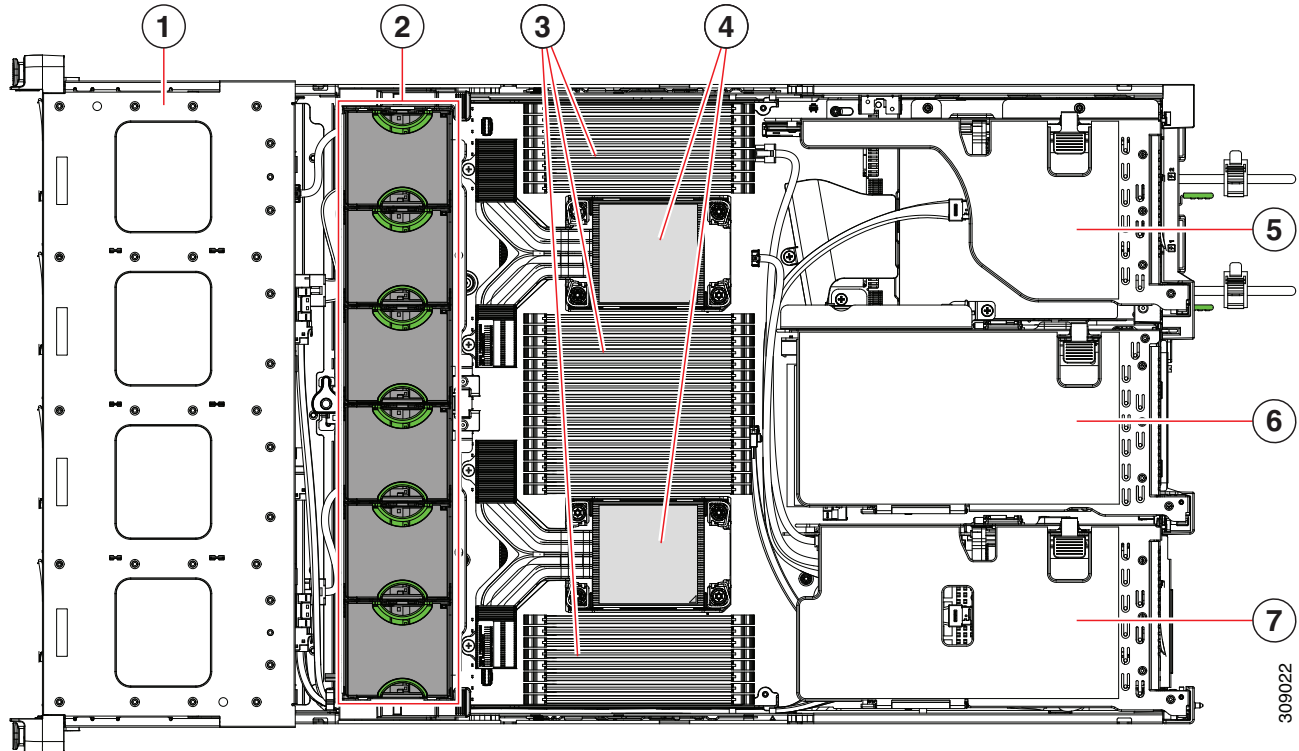

1	Front-loading drive bays	2	Cooling fan modules (six, hot-swappable)
3	DIMM sockets on motherboard (16 per CPU) An air baffle rests on top of the DIMMs and CPUs when the server is operating. The air baffle is not displayed in this illustration.	4	CPU sockets CPU 2 is at the top and CPU 1 is at the bottom.
5	PCIe riser 3 (PCIe slots 7 and 8 numbered from bottom to top), with the following options: <ul style="list-style-type: none"> <li>■ 3A (Default Option)—Slots 7 (x24 mechanical, x8 electrical), and 8 (x24 mechanical, x8 electrical). Both slots can accept a full height, full length GPU card.</li> <li>■ 3C (GPU Option)—Slots 7 (x24 mechanical, x16 electrical) and 8 empty (NCSI support limited to one slot at a time). Slot 7 can support a full height, full length, double-wide GPU card.</li> </ul>	6	PCIe riser 2 (PCIe slots 4, 5, 6 numbered from bottom to top), with the following options: <ul style="list-style-type: none"> <li>■ 2A (Default Option)—Slot 4 (x24 mechanical, x8 electrical) supports full height, ¾ length card; Slot 5 (x24 mechanical, x16 electrical) supports full height, full length GPU card; Slot 6 (x24 mechanical, x8 electrical) supports full height, full length card.</li> </ul>

7	PCIe riser 1 (PCIe slot 1, 2, 3 numbered bottom to top), with the following options: <ul style="list-style-type: none"><li>■ 1A (Default Option)—Slot 1 (x24 mechanical, x8 electrical) supports full height, ¾ length card; Slot 2 (x24 mechanical, x16 electrical) supports full height, full length GPU card; Slot 3 (x24 mechanical, x8 electrical) supports full height, full length card.</li></ul>	-	
---	---	---	--



## Risers

Figure 9 shows the locations of the PCIe riser connectors on the HClAF240C M6 All-Flash Server motherboard.

Figure 9 HClAF240C M6 All-Flash Server Riser Connector Locations

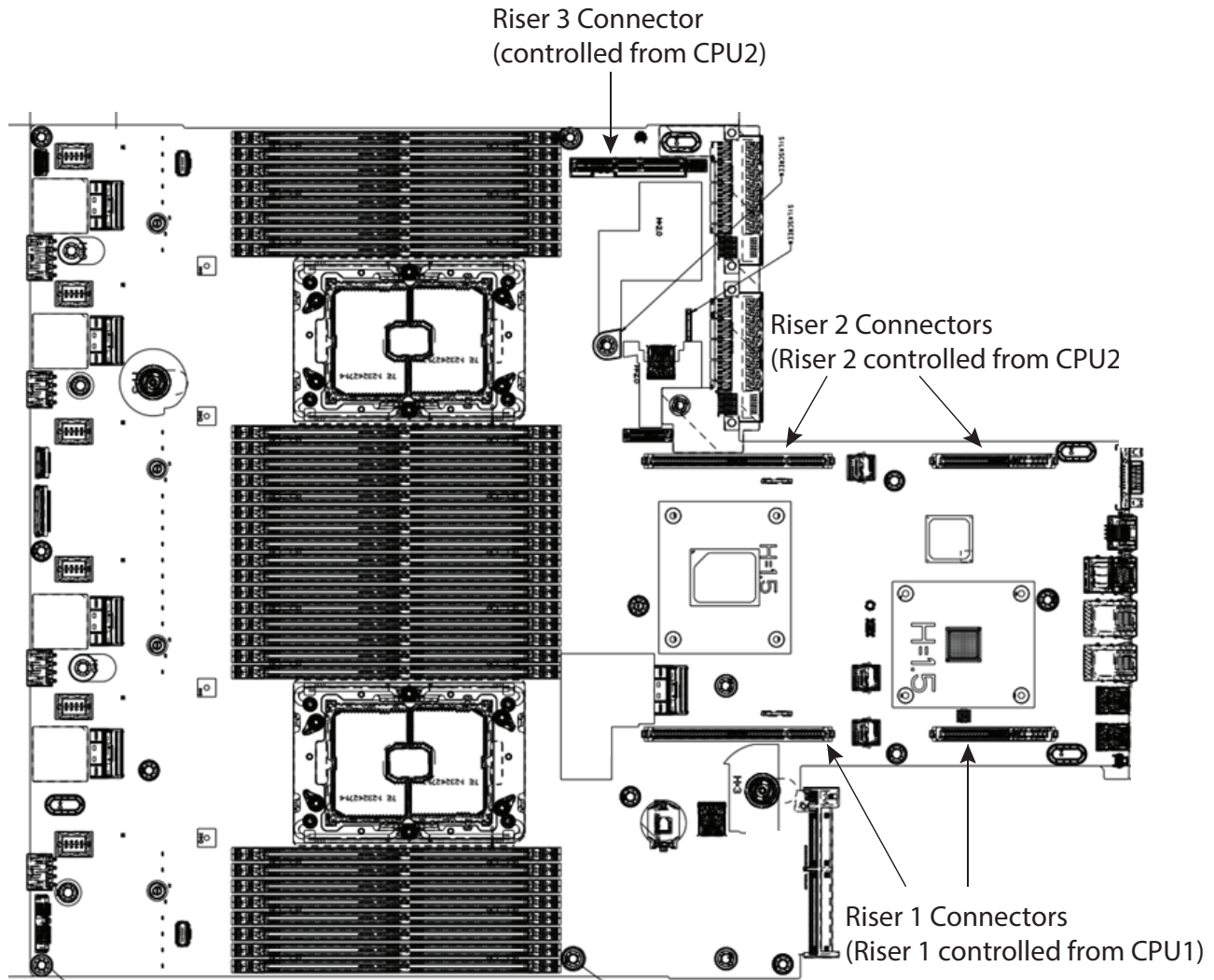
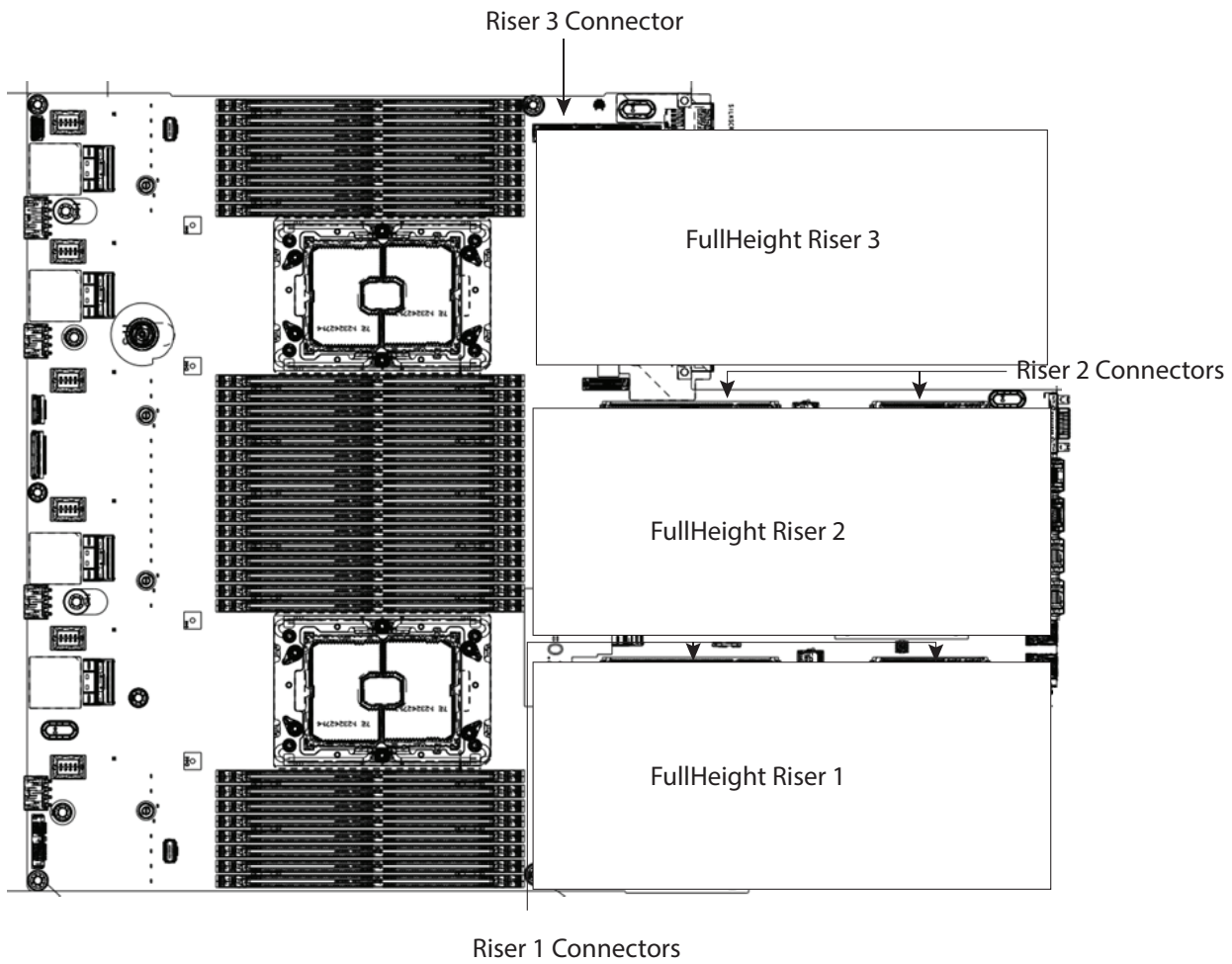

Figure 10 shows the locations of the PCIe riser connectors on the HCIAF240C M6 All-Flash Server motherboard.

Figure 10 HCIAF240C M6 All-Flash Server Riser Connector Locations



## Riser Card Configuration and Options

The riser card locations are shown in *Figure 11*.

**Figure 11** Riser Card Locations

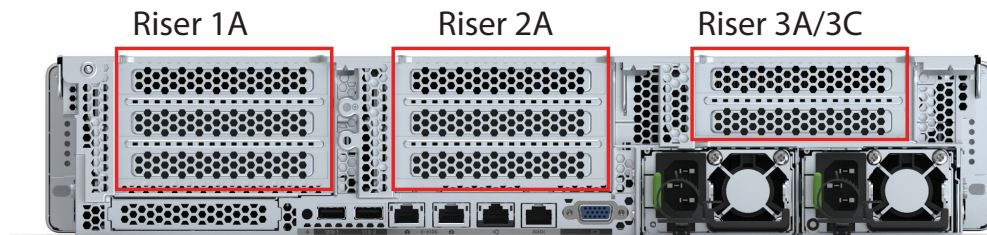

### Riser 1A

Riser 1A mechanical information is shown in *Figure 12*.

**Figure 12** Riser Card 1A

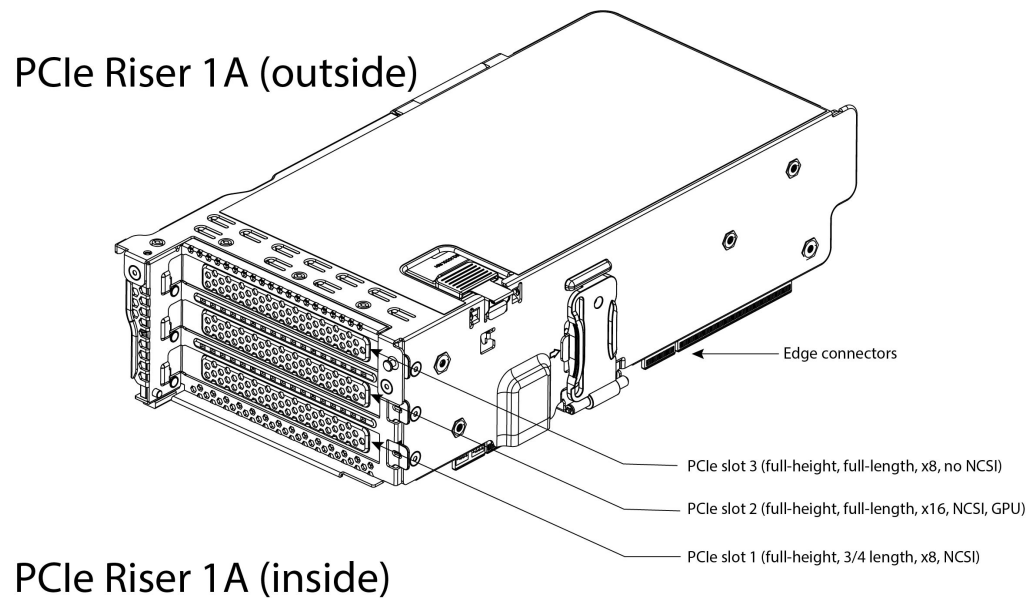

## Riser 2A

Riser 2A mechanical information is shown in [Figure 13](#).

Figure 13 Riser Card 2A

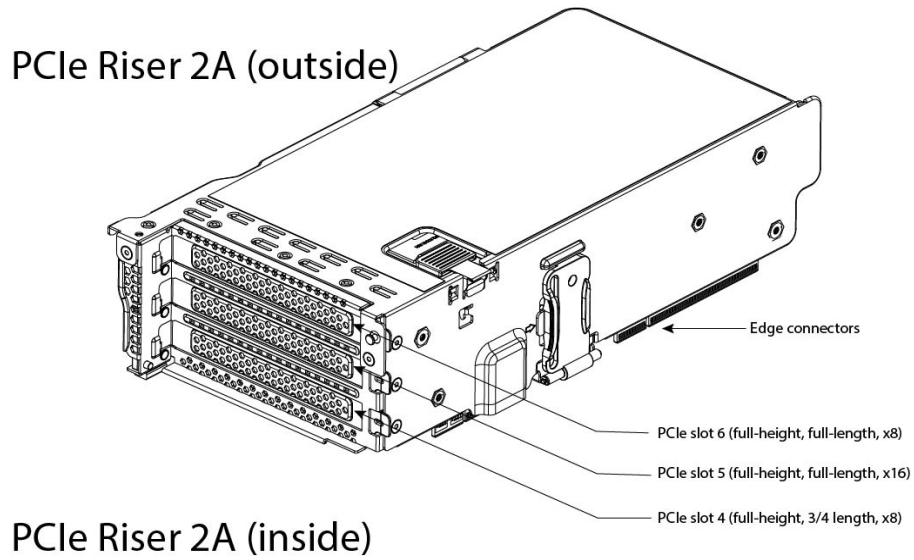

## PCIe Riser 2A (inside)

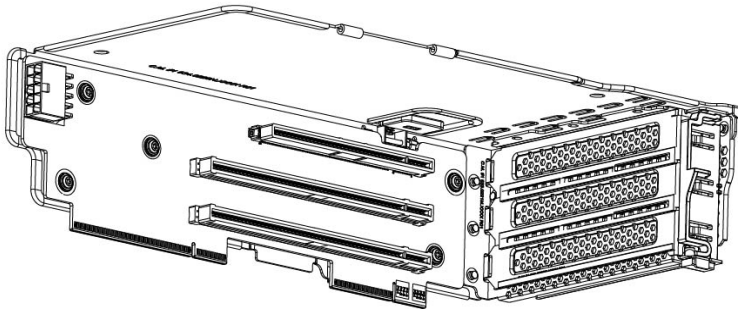

## Riser 3A

Riser 3A mechanical information is shown in [Figure 14](#).

Figure 14 Riser Card 3A

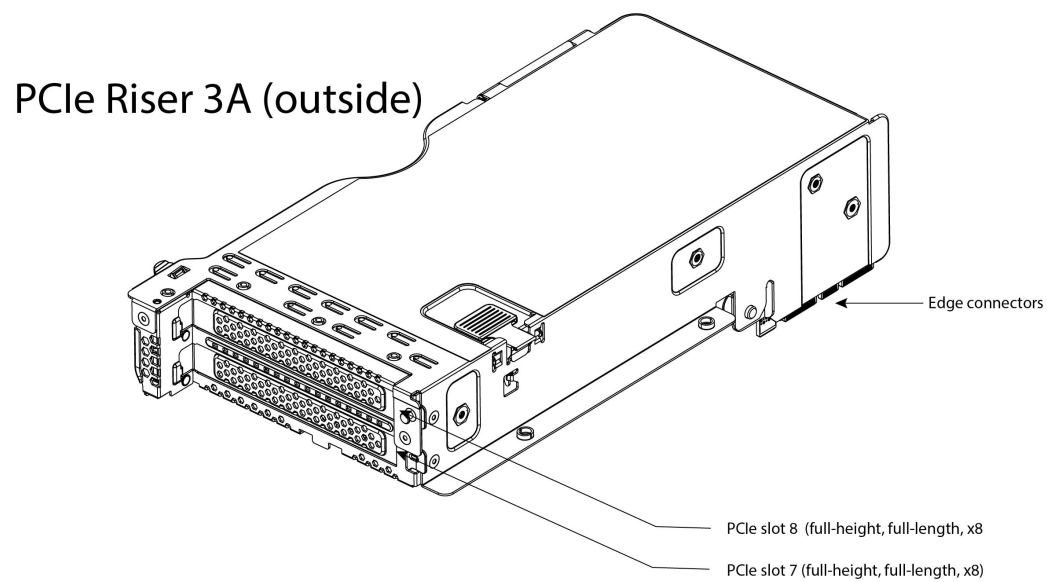

## PCIe Riser 3A (inside)

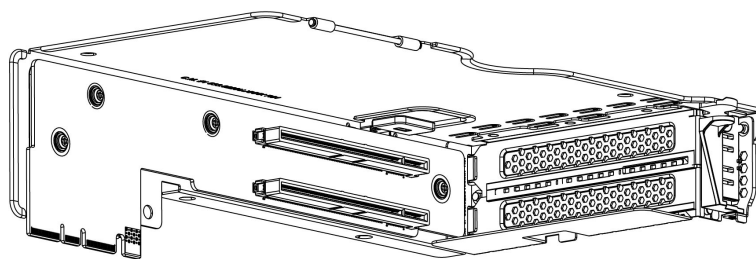

## Riser 3C

Riser 3C mechanical information is shown in [Figure 15](#).

Figure 15 Riser Card 3C

### PCIe Riser 3C (outside)

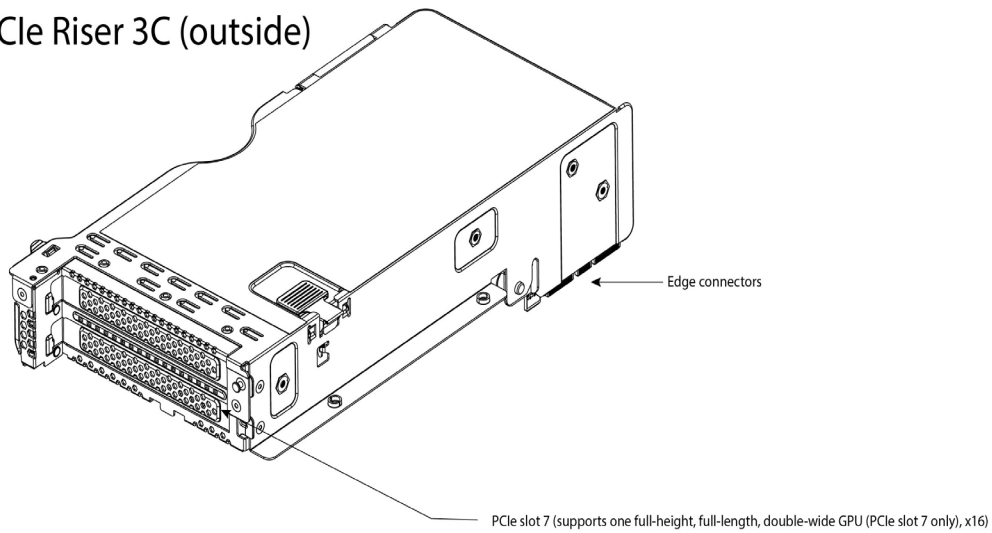

### PCIe Riser 3C (inside)

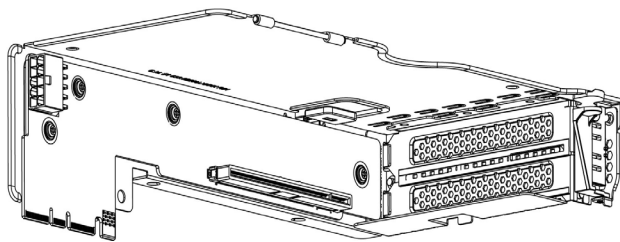

## UPGRADING or REPLACING CPUs



**NOTE:** Before servicing any CPU, do the following:

- Decommission and power off the server.
- Slide the HClAF240C M6 All-Flash Server out from the rack.
- Remove the top cover.

To replace an existing CPU, follow these steps:

(1) Have the following tools and materials available for the procedure:

- T-30 Torx driver—Supplied with replacement CPU.
- #1 flat-head screwdriver—Supplied with replacement CPU.
- CPU assembly tool—Supplied with replacement CPU. Can be ordered separately as Cisco PID UCS-CPUAT=.
- Heatsink cleaning kit—Supplied with replacement CPU. Can be ordered separately as Cisco PID UCSX-HSCK=.
- Thermal interface material (TIM)—Syringe supplied with replacement CPU. Can be ordered separately as Cisco PID UCS-CPU-TIM=.

(2) Order the appropriate replacement CPU from [Table 6 on page 14](#):

Carefully remove and replace the CPU and heatsink in accordance with the instructions found in “[Cisco server Installation and Service Guide](#)”

To add a new CPU, follow these steps:

(1) Have the following tools and materials available for the procedure:

- T-30 Torx driver—Supplied with new CPU.
- #1 flat-head screwdriver—Supplied with new CPU
- CPU assembly tool—Supplied with new CPU. Can be ordered separately as Cisco PID UCS-CPUAT=
- Thermal interface material (TIM)—Syringe supplied with replacement CPU. Can be ordered separately as Cisco PID UCS-CPU-TIM=

(2) Order the appropriate new CPU from [Table 6 on page 14](#)

(3) Order one heat sink for each new CPU. Order PID UCSC-HSHP-240M6= for servers with no GPU. Order PID UCSC-HSLP-M6= for servers with GPUs.

Carefully install the CPU and heatsink in accordance with the instructions found in “[Cisco server Installation and Service Guide](#)”

## UPGRADING or REPLACING MEMORY



**NOTE:** Before servicing any DIMM do the following:

- Decommission and power off the server.
- Remove the top cover from the server
- Slide the server out the front of the chassis.

To add or replace DIMMs, follow these steps:

Step 1 Open both DIMM connector latches.

Step 2 Press evenly on both ends of the DIMM until it clicks into place in its slot

Note: Ensure that the notch in the DIMM aligns with the slot. If the notch is misaligned, it is possible to damage the DIMM, the slot, or both.

Step 3 Press the DIMM connector latches inward slightly to seat them fully.

Step 4 Populate all slots with a DIMM or DIMM blank. A slot cannot be empty.

Figure 16 Replacing Memory

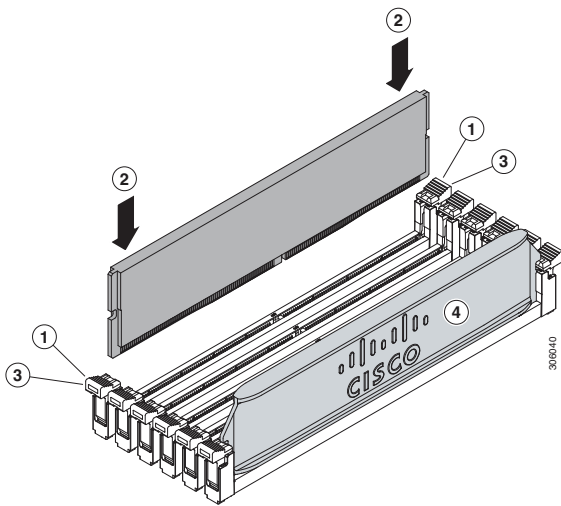

For additional details on replacing or upgrading DIMMs, see “[Cisco server Installation and Service Guide](#)”



# TECHNICAL SPECIFICATIONS

## Dimensions and Weight

Table 39 HClAF240C M6 All-Flash Server Dimensions and Weight

Parameter	Value
Height	3.42 in. (8.7 cm)
Width (Not including slam latches)	16.9 in. (42.9 cm)
Width (including slam latches)	18.9 in. (48.0 cm)
Depth	30 in. (76.2 cm)
Front Clearance	3 in. (76 mm)
Side Clearance	1 in. (25 mm)
Rear Clearance	6 in. (152 mm)
<b>Weight</b>	
Weight with following options and no rail kit: 0 HDD, 0 CPU, 0 DIMM, and 1 2300 W power supply	35.7 lbs (16.2 kg)
Weight with following options and including rail kit: 0 HDD, 0 CPU, 0 DIMM, and 1 2300 W power supply	44 lbs (20 kg)
Weight with following options and no rail kit: 1 HDD, 1 CPU, 1 DIMM, and 1 2300 W power supply	37.6 lbs (17 kg)
Weight with following options and including rail kit: 1 HDD, 1 CPU, 1 DIMM, and 1 2300 W power supply	45.9 lbs (20.8 kg)
Weight with following options and no rail kit: 8 HDDs, 2 CPUs, 32 DIMMs, and 2 2300 W power supplies	44.71 lbs (20.28 kg)
Weight with following options and including rail kit: 8 HDDs, 2 CPUs, 32 DIMMs, and 2 2300 W power supplies	49.2 lbs (22.32 kg)
Weight with following options and no rail kit: 0 HDD, 0 CPU, 0 DIMM, and 1 2300 W power supply	33.14 lbs (15 kg)
Weight with following options and including rail kit: 0 HDD, 0 CPU, 0 DIMM, and 1 2300 W power supply	41.45 lbs (18.8 kg)
Weight with following options and no rail kit: 1 HDD, 1 CPU, 1 DIMM, and 1 2300 W power supply	40.55 lbs (18.4kg)
Weight with following options and including rail kit: 1 HDD, 1 CPU, 1 DIMM, and 1 2300 W power supply	48.86 lbs (22.2 kg)
Weight with following options and no rail kit: 24 HDDs, 2 CPUs, 32 DIMMs, and 2 2300 W power supplies	58.8 lbs (26.7 kg)
Weight with following options and including rail kit: 24 HDDs, 2 CPUs, 32 DIMMs, and 2 2300 W power supplies	61.7 lbs (28 kg)

## Power Specifications

The server is available with the following types of power supplies:

- 1050 W (AC) power supply (see [Table 40](#)).
- 1050 W V2 (DC) power supply (see [Table 41](#))
- 1600 W (AC) power supply (see [Table 42](#))
- 2300 W (AC) power supply (see [Table 43](#))

**Table 40 HClAF240C M6 All-Flash Server Power Specifications (1050 W AC power supply)**

Parameter	Specification			
Input Connector	IEC320 C14			
Input Voltage Range (V rms)	100 to 240			
Maximum Allowable Input Voltage Range (V rms)	90 to 264			
Frequency Range (Hz)	50 to 60			
Maximum Allowable Frequency Range (Hz)	47 to 63			
Maximum Rated Output (W) <sup>1</sup>	800		1050	
Maximum Rated Standby Output (W)	36			
Nominal Input Voltage (V rms)	100	120	208	230
Nominal Input Current (A rms)	9.2	7.6	5.8	5.2
Maximum Input at Nominal Input Voltage (W)	889	889	1167	1154
Maximum Input at Nominal Input Voltage (VA)	916	916	1203	1190
Minimum Rated Efficiency (%) <sup>2</sup>	90	90	90	91
Minimum Rated Power Factor <sup>2</sup>	0.97	0.97	0.97	0.97
Maximum Inrush Current (A peak)	15			
Maximum Inrush Current (ms)	0.2			
Minimum Ride-Through Time (ms) <sup>3</sup>	12			

**Notes:**

1. Maximum rated output is limited to 800W when operating at low-line input voltage (100-127V)
2. This is the minimum rating required to achieve 80 PLUS Platinum certification, see test reports published at <http://www.80plus.org/> for certified values
3. Time output voltage remains within regulation limits at 100% load, during input voltage dropout

Table 41 HClAF240C M6 All-Flash Server Power Specifications (1050 W V2 DC power supply)

Parameter	Specification
Input Connector	Molex 42820
Input Voltage Range (V rms)	-48
Maximum Allowable Input Voltage Range (V rms)	-40 to -72
Frequency Range (Hz)	NA
Maximum Allowable Frequency Range (Hz)	NA
Maximum Rated Output (W)	1050
Maximum Rated Standby Output (W)	36
Nominal Input Voltage (V rms)	-48
Nominal Input Current (A rms)	24
Maximum Input at Nominal Input Voltage (W)	1154
Maximum Input at Nominal Input Voltage (VA)	1154
Minimum Rated Efficiency (%) <sup>1</sup>	91
Minimum Rated Power Factor <sup>1</sup>	NA
Maximum Inrush Current (A peak)	15
Maximum Inrush Current (ms)	0.2
Minimum Ride-Through Time (ms) <sup>2</sup>	5

Notes:

1. This is the minimum rating required to achieve 80 PLUS Platinum certification, see test reports published at <http://www.80plus.org/> for certified values
2. Time output voltage remains within regulation limits at 100% load, during input voltage dropout

Table 42 HClAF240C M6 All-Flash Server 1600 W (AC) Power Supply Specifications

Parameter	Specification			
Input Connector	IEC320 C14			
Input Voltage Range (V rms)	200 to 240			
Maximum Allowable Input Voltage Range (V rms)	180 to 264			
Frequency Range (Hz)	50 to 60			
Maximum Allowable Frequency Range (Hz)	47 to 63			
Maximum Rated Output (W)	1600			
Maximum Rated Standby Output (W)	36			
Nominal Input Voltage (V rms)	100	120	208	230
Nominal Input Current (A rms)	NA	NA	8.8	7.9
Maximum Input at Nominal Input Voltage (W)	NA	NA	1778	1758
Maximum Input at Nominal Input Voltage (VA)	NA	NA	1833	1813
Minimum Rated Efficiency (%) <sup>1</sup>	NA	NA	90	91
Minimum Rated Power Factor <sup>2</sup>	NA	NA	0.97	0.97
Maximum Inrush Current (A peak)	30			
Maximum Inrush Current (ms)	0.2			
Minimum Ride-Through Time (ms) <sup>2</sup>	12			

Notes:

1. This is the minimum rating required to achieve 80 PLUS Platinum certification, see test reports published at <http://www.80plus.org/> for certified values
2. Time output voltage remains within regulation limits at 100% load, during input voltage dropout

Table 43 HClAF240C M6 All-Flash Server 2300 W (AC) Power Supply Specifications

Parameter	Specification			
Input Connector	IEC320 C20			
Input Voltage Range (Vrms)	100 to 240			
Maximum Allowable Input Voltage Range (Vrms)	90 to 264			
Frequency Range (Hz)	50 to 60			
Maximum Allowable Frequency Range (Hz)	47 to 63			
Maximum Rated Output (W) <sup>1</sup>	2300			
Maximum Rated Standby Output (W)	36			
Nominal Input Voltage (Vrms)	100	120	208	230
Nominal Input Current (Arms)	13	11	12	10.8
Maximum Input at Nominal Input Voltage (W)	1338	1330	2490	2480
Maximum Input at Nominal Input Voltage (VA)	1351	1343	2515	2505
Minimum Rated Efficiency (%) <sup>2</sup>	92	92	93	93
Minimum Rated Power Factor <sup>2</sup>	0.99	0.99	0.97	0.97
Maximum Inrush Current (A peak)	30			
Maximum Inrush Current (ms)	0.2			
Minimum Ride-Through Time (ms) <sup>3</sup>	12			

**Notes:**

1. Maximum rated output is limited to 1200W when operating at low-line input voltage (100-127V)
2. This is the minimum rating required to achieve 80 PLUS Titanium certification, see test reports published at <http://www.80plus.org/> for certified values
3. Time output voltage remains within regulation limits at 100% load, during input voltage dropout

For configuration-specific power specifications, use the Cisco UCS Power Calculator at this URL:

<http://ucspowercalc.cisco.com>

## Environmental Specifications

The environmental specifications for the HClAF240C M6 All-Flash Server are listed in [Table 44](#).

**Table 44 Environmental Specifications**

Parameter	Minimum
Operating Temperature	Dry bulb temperature of 10°C to 35°C (50°F to 95°F) Maximum temperature change of 20°C (36°F) per hour (a temperature change within a specified period of time and not a rate of change) Humidity condition: Uncontrolled, not to exceed 50% RH starting condition Derate the maximum temperature by 1°C (33.8°F) per every 305 meters of altitude above 900m
Extended Operating Temperature	5°C to 40°C (41°F to 104°F) with no direct sunlight Humidity condition: Uncontrolled, not to exceed 50% RH starting condition Derate the maximum temperature by 1°C (33.8°F) per every 305 meters of altitude above 900m
Non-Operating Temperature	Dry bulb temperature of -40°C to 65°C (-40°F to 149°F)
Operating Relative Humidity	10% to 90% and 28°C (82.4°F) maximum dew-point temperature, non-condensing environment Minimum to be higher (more moisture) of -12°C (10.4°F) dew point or 8% relative humidity Maximum to be 24°C (75.2°F) dew point or 90% relative humidity
Non-Operating Relative Humidity	5% to 93% relative humidity, non-condensing, with a maximum wet bulb temperature of 28°C across the 20°C to 40°C dry bulb range.
Maximum Operating Duration	Unlimited
Operating Altitude	A maximum elevation of 3050 meters (10,006 ft)
Non-Operating Altitude	An elevation of 0 to 12,000 meters (39,370 ft)
Sound Power level, Measure A-weighted per ISO7779 LWAd (Bels) Operation at 23°C (73°F)	5.5
Sound Pressure level, Measure A-weighted per ISO7779 LpAm (dBA) Operation at 23°C (73°F)	40

## Extended Operating Temperature Hardware Configuration Limits

Table 45 HClAF240C M6 All-Flash Server Extended Operating Temperature Hardware Configuration Limits

Platform <sup>1</sup>	ASHRAE A3 (5°C to 40°C) <sup>2</sup>	ASHRAE A4 (5°C to 45°C) <sup>3</sup>
Processors:	155W+	155W+ and 105W+ (4 or 6 Cores)
Memory:	LRDIMMs	LRDIMMs
Storage:	M.2 SATA SSDs NVMe SSDs	M.2 SATA SSDs NVMe SSDs HDDs or SSDs (Rear Bays)
Peripherals:	PCIe NVMe SSDs GPUs	PCIe NVMe SSDs GPUs VICs (Slots 1 and 4) NICs (Slots 1 and 4) HBAs (Slots 1 and 4)

**Notes:**

1. Two PSUs are required and PSU failure is not supported
2. Non-Cisco UCS qualified peripherals and/or peripherals that consume more than 25W are not supported
3. High power or maximum power fan control policy must be applied

## Compliance Requirements

The regulatory compliance requirements for HCI-Series servers are listed in [Table 46](#)

**Table 46 HCI-Series Regulatory Compliance Requirements**

Parameter	Description
Regulatory Compliance	Products should comply with CE Markings per directives 2014/30/EU and 2014/35/EU
Safety	UL 60950-1 Second Edition CAN/CSA-C22.2 No. 60950-1 Second Edition EN 60950-1 Second Edition IEC 60950-1 Second Edition AS/NZS 60950-1 GB4943 2001
EMC - Emissions	47CFR Part 15 (CFR 47) Class A AS/NZS CISPR32 Class A CISPR32 Class A EN55032 Class A ICES003 Class A VCCI Class A EN61000-3-2 EN61000-3-3 KN32 Class A CNS13438 Class A
EMC - Immunity	EN55024 CISPR24 EN300386 KN35



**Americas Headquarters**  
Cisco Systems, Inc.  
San Jose, CA

**Asia Pacific Headquarters**  
Cisco Systems (USA) Pte. Ltd.  
Singapore

**Europe Headquarters**  
Cisco Systems International BV Amsterdam,  
The Netherlands

Cisco has more than 200 offices worldwide. Addresses, phone numbers, and fax numbers are listed on the Cisco Website at [www.cisco.com/go/offices](http://www.cisco.com/go/offices).

Cisco and the Cisco Logo are trademarks of Cisco Systems, Inc. and/or its affiliates in the U.S. and other countries. A listing of Cisco's trademarks can be found at [www.cisco.com/go/trademarks](http://www.cisco.com/go/trademarks). Third party trademarks mentioned are the property of their respective owners. The use of the word partner does not imply a partnership relationship between Cisco and any other company. (1005R)



